

---

## **OMRON Product References**

All OMRON products are capitalized in this manual.

### **Visual Aids**

The following headings appear in the left column of the manual to help you locate different types of information.

**Note** Indicates information of particular interest for efficient and convenient operation of the product.

The finless type is the recognized component by Underwriters Laboratories Inc. This manual describes "Conditions of acceptability".

#### **© OMRON, 2001**

All rights reserved. No part of this publication may be reproduced, stored in a retrieval system, or transmitted, in any form, or by any means, mechanical, electronic, photocopying, recording, or otherwise, without the prior written permission of OMRON.

No patent liability is assumed with respect to the use of the information contained herein. Moreover, because OMRON is constantly striving to improve its high-quality products, the information contained in this manual is subject to change without notice. Every precaution has been taken in the preparation of this manual. Nevertheless, OMRON assumes no responsibility for errors or omissions. Neither is any liability assumed for damages resulting from the use of the information contained in this publication.

# OMRON



## INSTALLATION GUIDELINE

### 3G3MV / 3G3JV

FINLESS TYPE

Wiki *لاہزار آن لائن*  
**LZonline**  
[laleharonline.com/wiki](http://laleharonline.com/wiki)



---

# PREFACE

OMRON'S 3G3MV/3G3JV are easy and simple frequency inverter. This manual describes installation conditions and dimensions of 3G3MV/3G3JV. Read this instruction manual thoroughly before operation.

The finless type inverter is the recognized component by Underwriters Laboratories Inc. This manual describes "Conditions of acceptability." Read this installation guideline and the instruction manual of the inverter thoroughly before installation and operation. Following shows the manual No. of user manuals: 3G3MV: I527-E2, 3G3JV: I528-E2

OMRON Europe B.V.

## General precautions

- This manual may be modified when necessary because of the improvement of the product, modification, or changes in specifications.  
Such modifications are denoted by a revised manual No.
- To order a copy of this manual, if your copy has been damaged or or lost, contact your OMRON representative.
- OMRON is not responsible for any modification of the product made by the user, since that will void your guarantee.

---

## **Notice:**

OMRON products are manufactured for use according to proper procedures by a qualified operator and only for the purposes described in this manual.

The following conventions are used to indicate and classify precautions in this manual. Always heed the information provided with them. Failure to heed precautions can result in injury to people or damage to property.

 **DANGER** Indicates an imminently hazardous situation which, if not avoided, will result in death or serious injury.

 **WARNING** Indicates a potentially hazardous situation which, if not avoided, could result in death or serious injury.

 **Caution** Indicates a potentially hazardous situation which, if not avoided, may result in minor or moderate injury, or property damage.









---

## General Precautions

Observe the following precautions when using the SYSDRIVE Inverters and peripheral devices.



This manual may include illustrations of the product with protective covers removed in order to describe the components of the product in detail. Make sure that these protective covers are on the product before use.

Consult your OMRON representative when using the product after a long period of storage.





-  **WARNING** Do not touch the inside of the Inverter. Doing so may result in electrical shock.
-  **WARNING** Operation, maintenance, or inspection must be performed after turning OFF the power supply, confirming that the CHARGE indicator (or status indicators) are OFF, and after waiting for the time specified on the front cover. Not doing so may result in electrical shock.
-  **WARNING** Do not damage, pull on, apply stress to, place heavy objects on, or pinch the cables. Doing so may result in electrical shock.
-  **WARNING** Do not touch the rotating parts of the motor under operation. Doing so may result in injury.
-  **WARNING** Do not modify the product. Doing so may result in injury or damage to the product.
-  **Caution** Do not store, install, or operate the product in the following places. Doing so may result in electrical shock, fire or damage to the product.
  - Locations subject to direct sunlight.
  - Locations subject to temperatures or humidity outside the range specified in the specifications.
  - Locations subject to condensation as the result of severe changes in temperature.
  - Locations subject to corrosive or flammable gases.
  - Locations subject to exposure to combustibles.
  - Locations subject to dust (especially iron dust) or salts.
  - Locations subject to exposure to water, oil, or chemicals.
  - Locations subject to shock or vibration.
-  **Caution** Do not touch the Inverter radiator, regenerative resistor, or Servomotor while the power is being supplied or soon after the power is turned OFF. Doing so may result in a skin burn due to the hot surface.
-  **Caution** Do not conduct a dielectric strength test on any part of the Inverter. Doing so may result in damage to the product or malfunction.
-  **Caution** Take appropriate and sufficient countermeasures when installing systems in the following locations. Not doing so may result in equipment damage.
  - Locations subject to static electricity or other forms of noise.
  - Locations subject to strong electromagnetic fields and magnetic fields.
  - Locations subject to possible exposure to radioactivity.
  - Locations close to power supplies.

---





## ***Transportation Precautions***







-  **Caution** Do not hold by front cover or panel, instead, hold by the radiation fin (heat sink) while transporting the product. Doing so may result in injury.
-  **Caution** Do not pull on the cables. Doing so may result in damage to the product or malfunction.
-  **Caution** Use the eye-bolts only for transporting the Inverter. Using them for transporting the machinery may result in injury or malfunction.

## ***Installation Precautions***







-  **WARNING** Provide an appropriate stopping device on the machine side to secure safety. (A holding brake is not a stopping device for securing safety.) Not doing so may result in injury.
-  **WARNING** Provide an external emergency stopping device that allows an instantaneous stop of operation and power interruption. Not doing so may result in injury.
-  **Caution** Be sure to install the product in the correct direction and provide specified clearances between the Inverter and control panel or with other devices. Not doing so may result in fire or malfunction.
-  **Caution** Do not allow foreign objects to enter inside the product. Doing so may result in fire or malfunction.
-  **Caution** Do not apply any strong impact. Doing so may result in damage to the product or malfunction.

## ***Wiring Precautions***

-  **WARNING** Wiring must be performed only after confirming that the power supply has been turned OFF. Not doing so may result in electrical shock.
-  **WARNING** Wiring must be performed by authorized personnel. Not doing so may result in electrical shock or fire.
-  **WARNING** Be sure to confirm operation only after wiring the emergency stop circuit. Not doing so may result in injury.
-  **WARNING** Always connect the ground terminals to a ground of 100  $\Omega$  or less for the 200-VAC class, or 10  $\Omega$  or less for the 400-VAC class. Not connecting to a proper ground may result in electrical shock.

- 
-  **Caution** Install external breakers and take other safety measures against short-circuiting in external wiring. Not doing so may result in fire.
  -  **Caution** Confirm that the rated input voltage of the Inverter is the same as the AC power supply voltage. An incorrect power supply may result in fire, injury, or malfunction.
  -  **Caution** Connect the Braking Resistor and Braking Resistor Unit as specified in the manual. Not doing so may result in fire.
  -  **Caution** Be sure to wire correctly and securely. Not doing so may result in injury or damage to the product.
  -  **Caution** Be sure to firmly tighten the screws on the terminal block. Not doing so may result in fire, injury, or damage to the product.
  -  **Caution** Do not connect an AC power to the U, V, or W output. Doing so may result in damage to the product or malfunction.

## ***Operation and Adjustment Precautions***

-  **WARNING** Turn ON the input power supply only after mounting the front cover, terminal covers, bottom cover, Operator, and optional items. Not doing so may result in electrical shock.
-  **WARNING** Do not remove the front cover, terminal covers, bottom cover, Operator, or optional items while the power is being supplied. Not doing so may result in electrical shock.
-  **WARNING** Do not operate the Operator or switches with wet hands. Doing so may result in electrical shock.
-  **WARNING** Do not touch the inside of the Inverter. Doing so may result in electrical shock.
-  **WARNING** Do not come close to the machine when using the error retry function because the machine may abruptly start when stopped by an alarm. Doing so may result in injury.
-  **WARNING** Do not come close to the machine immediately after resetting momentary power interruption to avoid an unexpected restart (if operation is set to be continued in the processing selection function after momentary power interruption is reset). Doing so may result in injury.
-  **WARNING** Provide a separate emergency stop switch because the STOP Key on the Operator is valid only when function settings are performed. Not doing so may result in injury.

---

 **WARNING** Be sure confirm that the RUN signal is turned OFF before turning ON the power supply, resetting the alarm, or switching the LOCAL/REMOTE selector. Doing so while the RUN signal is turned ON may result in injury.

 **Caution** Be sure to confirm permissible ranges of motors and machines before operation because the Inverter speed can be easily changed from low to high. Not doing so may result in damage to the product.

 **Caution** Provide a separate holding brake when necessary. Not doing so may result in injury.

 **Caution** Do not perform a signal check during operation. Doing so may result in injury or damage to the product.

 **Caution** Do not carelessly change settings. Doing so may result in injury or damage to the product.

## ***Maintenance and Inspection Precautions***

 **WARNING** Do not touch the Inverter terminals while the power is being supplied.

 **WARNING** Maintenance or inspection must be performed only after turning OFF the power supply, confirming that the CHARGE indicator (or status indicators) is turned OFF, and after waiting for the time specified on the front cover. Not doing so may result in electrical shock.

 **WARNING** Maintenance, inspection, or parts replacement must be performed by authorized personnel. Not doing so may result in electrical shock or injury.

 **WARNING** Do not attempt to take the Unit apart or repair. Doing either of these may result in electrical shock or injury.

 **Caution** Carefully handle the Inverter because it uses semiconductor elements. Careless handling may result in malfunction.

 **Caution** Do not change wiring, disconnect connector, the Operator, or optional items, or Replace fans while power is being supplied. Doing so may result in injury, damage to the product, or malfunction.

---

## ■ Warnings for UL/cUL Marking

- Do not connect or disconnect wiring, or perform signal checks while the power supply is turned ON.
- The Inverter internal capacitor is still charged even after the power supply is turned OFF. To prevent electrical shock, disconnect all power before servicing the Inverter. Then wait at least one minute after the power supply is disconnected and all indicators are OFF.
- Do not perform a withstand voltage test on any part of the Inverter. This electronic equipment uses semiconductors and is vulnerable to high voltage.
- Do not remove the Digital Operator or the blank cover unless the power supply is turned OFF. Never touch the printed control board (PCB) while the power supply is turned ON.
- The Inverter is not suitable for use on a circuit capable of delivering more than 5.000 RMS symmetrical amperes, 250 volts maximum (200-V-class Units) or 18.000 RMS symmetrical amperes, 480 V maximum (400-V-class Units).

<b>CAUTION</b>
Use 75°C copper wires or equivalent. Low voltage wires shall be wired with Class I Wiring.

# Checking Before Unpacking

## ■ Checking the Product

On delivery, always check that the delivered product is the SYSDRIVE 3G3MV or 3G3JV Inverter that you ordered.

Should you find any problems with the product, immediately contact your nearest local sales representative.

### • Checking the Nameplate

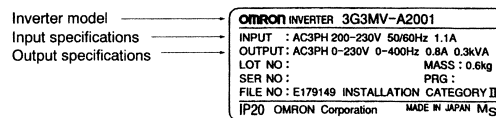

### • Checking the Model

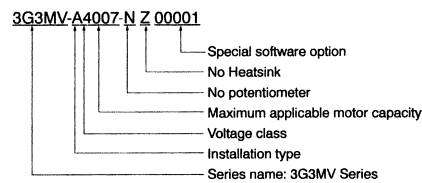

## Installation Type

A	Panel mounting models (IP10 min.) or Wall mounting closed models.
---	---

## Voltage Class

2	Three-phase 200-VAC input (200-V class)
B	Single-phase 200-VAC input (200-V class)
4	Three-phase 400-VAC input (400-V class)

---

### Maximum Applicable Motor Capacity

001	0.1 (0.1) kW
002	0.2 (0.25/0.37) kW
004	0.4 (0.55) kW
007	0.75 (1.1) kW
015	1.5 (1.5) kW
022	2.2 (2.2) kW
030	3.0 (3.0) kW
040	4.0 (4.0) kW
055	5.5 (5.5) kW (only 3G3MV)
075	7.5 (7.5) kW (only 3G3MV)

**Note** The figures in parentheses indicate capacities for motors used outside Japan.

### Front cover options

N	No potentiometer
---	------------------

### Heatsink option

Z	Finless type
---	--------------

### • Checking for Damage

Check the overall appearance and check for damage or scratches resulting from transportation.

### ■ Application Precautions

You must allow sufficient leeway in ratings and performance and provide proper fail-safe and other safety measures when using the Inverter in any of the following applications. Be sure also to consult with your OMRON representative before actually attempting any of these applications.

1. Applications under conditions or environments not specified in user manuals.
2. Applications for nuclear control systems, railroad systems, aviation systems, vehicles, combustion systems, medical equipment, amusement machines, and safety equipment.
3. Applications for other systems, machines, and equipment that may have a serious influence on lives and property if used improperly.

---

## CONDITIONS OF ACCEPTABILITY

- (1) In the end use application the enclosure internal temperature shall not exceed 50 Degrees C (122°F).  
Refer to the next page for details of mounting dimensions.
- (2) The maximum heatsink temperature shall not exceed 90 Degrees C (194°F).  
The temperature shall be 80 Degrees C (176°F) or less for inverters of 5.5/7.5 kW. The inverter generates the heat loss. Refer to Table 1.
- (3) The mating surface shall have the following properties:  
Surface flatness shall not exceed 0.2 mm across the entire cross sectional area of item 1.  
Surface finish shall not exceed 25S.
- (4) The surrounding mounting space (between device and enclosure) shall have the following dimensions:  
30 mm or greater from each side (inverters of 4.0 kW or less)  
50 mm or greater from each side (inverters of 5.5/7.5 kW)  
100 mm or greater from top and bottom  
For details or the mounting space, refer to fig. 1.
- (5) Recommended thermal compound to be applied on item 1 shall be Type G746, manufactured by Shin-Etsu Chemical Co., Ltd. or equivalent. 100 μ m shall be applied evenly across the entire surface area (inverters of 4.0 kW or less)
- (6) M4 screws shall be used for secureness onto end use heatsink with a tightening torque of 1.0 to 1.3 N.m.  
M5 (inverters of 5.5/7.5 kW) screws shall be used for secureness onto end use heatsink with a tightening torque of 2.0 to 2.5 N.m.  
Caution : When the inverter is not mounted adequately, it may cause over-heating or damage the inverter.

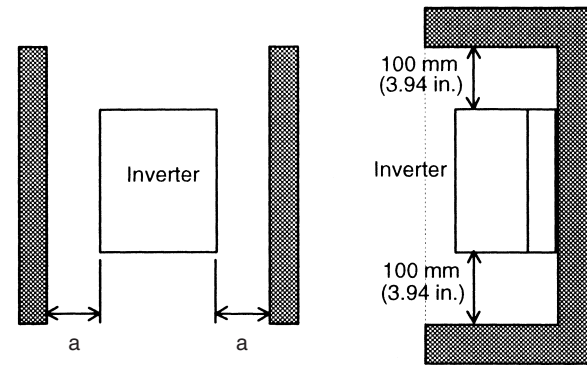

Voltage	Max. Applicable Motor Output kW (HP)	Length of a
200 V single-phase 3-phase 400 V 3-phase	3.7 kW (5HP) or less	30 mm (1.18 in.) or more
200 V 3-phase 400 V 3-phase	5.5 kW (7.5HP) 7.5 kW (10HP)	50 mm (1.97 in.) or more

Fig. 1 Mounting dimensions

Table 1 Heat Loss 3G3MV/3G3JV

Model	200 V single phase 3G3 (MV/JV) AB models								
	AB001	AB002	AB004	AB007	AB015	AB022	AB040		
Heatsink (W)	3.7	7.7	15.8	28.4	53.7	64.5	98.2		
Inside unit (W)	10.4	12.3	16.1	23.0	29.1	49.1	78.2		
Total (W)	14.1	20.0	31.9	51.4	82.8	113.6	176.4		
Model	200 V three phase 3G3 (MV/JV) A2 models								
	A2001	A2002	A2004	A2007	A2015	A2022	A2040	A2055*	A2075*
Heatsink (W)	3.7	7.7	15.8	28.4	53.7	60.4	96.7	170.4	219.2
Inside unit (W)	9.3	10.3	12.3	16.7	19.1	34.4	52.4	79.4	98.9
Total (W)	13.0	18.0	28.1	45.1	72.8	94.8	149.1	249.8	318.1
Model	400 V three phase 3G3 (MV/JV) A4 models								
	A4002	A4004	A4007	A4015	A4022	A4030	A4040	A4055*	A4075*
Heatsink (W)	9.4	15.1	30.3	45.8	50.5	58.2	79.9	168.8	209.6
Inside unit (W)	13.7	15.0	24.6	29.9	32.5	37.6	49.2	87.7	99.3
Total (W)	23.1	30.1	54.9	75.7	83.0	95.8	129.1	256.5	308.9

\*Note: only for 3G3MV

**HEAT CALCULATION**

The following is a simplified thermal model of the inverter. It explains the heat transfer from the sole plate of the finless inverter in order to maintain correct IGBT operating temperature.

Ex 3G3M(J)V-A2037

$$\theta_{f-a} = \frac{90 - 4.8 - 50}{96.7} = 0.36^\circ\text{C/W}$$

By using this formula the correct heat transfer required to maintain correct base plate temperature is achieved

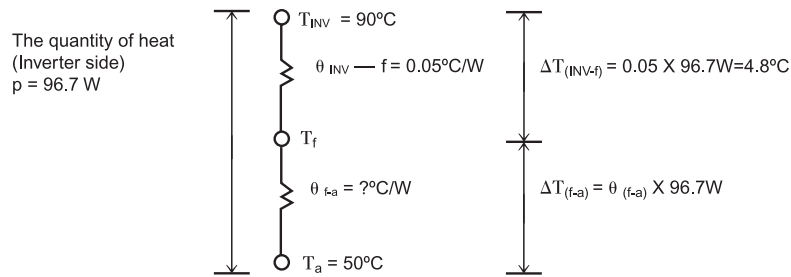
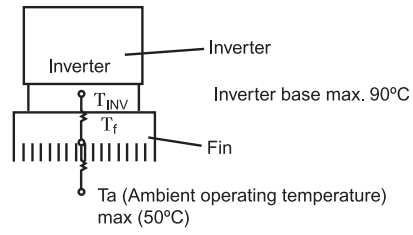

Note. heat transfer of all Inverter base is 0.05°C/W.

- Wiring 3G3JV
- control circuit

**Multi-function Contact Output (MA, MB, and MC)**

Terminal screw size	Tightening torque N • m	Wire	Wire size mm <sup>2</sup> (AWG)	Recommended wire size mm <sup>2</sup> (AWG)	Cable
M3	0.5 to 0.6	Single wire	0.5 to 1.25 (20 to 16)	0.75 (18)	Cable with polyethylene sheath
		Stranded wire	0.5 to 1.25 (20 to 16)		

**Sequential Input (S1 through S5 and SC) and Analog Monitor (AM or AC)**

Terminal screw size	Tightening torque N • m	Wire	Wire size mm <sup>2</sup> (AWG)	Recommended wire size mm <sup>2</sup> (AWG)	Cable
M2	0.22 to 0.25	Single wire	0.5 to 1.25 (20 to 16)	0.75 (18)	Cable with polyethylene sheath
		Stranded wire	0.5 to 0.75 (20 to 18)		

**Frequency Reference Input (FR, FS, and FC)**

Terminal screw size	Tightening torque N • m	Wire	Wire size mm <sup>2</sup> (AWG)	Recommended wire size mm <sup>2</sup> (AWG)	Cable
M2	0.22 to 0.25	Single wire	0.5 to 1.25 (20 to 16)	0.75 (18)	Special cable with polyethylene sheath and shield for measurement use
		Stranded wire	0.5 to 0.75 (20 to 18)		

• Main circuit (power cables: 600V vinyl cables, etc.) 3-phase 200-VAC Model

Model 3G3JV-	Terminal symbol	Terminal screw	Screw tightening torque (N•m)	Wire size (mm <sup>2</sup> )	Recommended wire size (mm <sup>2</sup> )	Molded-case circuit breaker capacity (A)
A2001	R/L1, S/L2, T/L3, -, +1, +2, U/T1, V/T2, W/T3	M3.5	0.8 to 1.0	0.75 to 2	2	5
	⊕					
A2002	R/L1, S/L2, T/L3, -, +1, +2, U/T1, V/T2, W/T3	M3.5	0.8 to 1.0	0.75 to 2	2	5
	⊕					
A2004	R/L1, S/L2, T/L3, -, +1, +2, U/T1, V/T2, W/T3	M3.5	0.8 to 1.0	0.75 to 2	2	5
	⊕					
A2007	R/L1, S/L2, T/L3, -, +1, +2, U/T1, V/T2, W/T3	M3.5	0.8 to 1.0	0.75 to 2	2	10
	⊕					
A2015	R/L1, S/L2, T/L3, -, +1, +2, U/T1, V/T2, W/T3	M3.5	0.8 to 1.0	2 to 5.5	2	20
	⊕					
A2022	R/L1, S/L2, T/L3, -, +1, +2, U/T1, V/T2, W/T3	M3.5	0.8 to 1.0	2 to 5.5	3.5	20
	⊕					
A2040	R/L1, S/L2, T/L3, -, +1, +2, U/T1, V/T2, W/T3	M3.5	1.2 to 1.5	2 to 5.5	5.5	30
	⊕					

Single-phase 200-VAC Model

Model 3G3JV-	Terminal symbol	Terminal screw	Terminal torque (N•m)	Wire size (mm <sup>2</sup> )	Recommended wire size (mm <sup>2</sup> )	Circuit breaker capacity (A)
AB001	R/L1, S/L2, T/L3, -, +1, +2, U/T1, V/T2, W/T3	M3.5	0.8 to 1.0	0.75 to 2	2	5
	⊕					
AB002	R/L1, S/L2, T/L3, -, +1, +2, U/T1, V/T2, W/T3	M3.5	0.8 to 1.0	0.75 to 2	2	5
	⊕					

Model 3G3JV-	Terminal symbol	Terminal screw	Terminal torque (N•m)	Wire size (mm <sup>2</sup> )	Recommended wire size (mm <sup>2</sup> )	Circuit breaker capacity (A)
AB004	R/L1, S/L2, T/L3, -, +1, +2, U/T1, V/T2, W/T3	M3.5	0.8 to 1.0	0.75 to 2	2	10
	⊕					
AB007	R/L1, S/L2, T/L3, -, +1, +2, U/T1, V/T2, W/T3	M3.5	0.8 to 1.0	2 to 5.5	3.5	20
	⊕				2	
AB015	R/L1, S/L2, T/L3, -, +1, +2, U/T1, V/T2, W/T3	M3.5	0.8 to 1.0	2 to 5.5	5.5	20
	⊕				2	

### 3-phase 400-VAC Model

Model 3G3JV-	Terminal symbol	Terminal screw	Terminal torque (N•m)	Wire size (mm <sup>2</sup> )	Recommended wire size (mm <sup>2</sup> )	Circuit breaker capacity (A)
A4002	R/L1, S/L2, T/L3, -, +1, +2, U/T1, V/T2, W/T3	M3.5	0.8 to 1.0	2 to 5.5	2	5
	⊕					
A4004	R/L1, S/L2, T/L3, -, +1, +2, U/T1, V/T2, W/T3	M3.5	0.8 to 1.0	2 to 5.5	2	5
	⊕					
A4007	R/L1, S/L2, T/L3, -, +1, +2, U/T1, V/T2, W/T3	M3.5	0.8 to 1.0	2 to 5.5	2	5
	⊕					
A4015	R/L1, S/L2, T/L3, -, +1, +2, U/T1, V/T2, W/T3	M3.5	0.8 to 1.0	2 to 5.5	2	10
	⊕					
A4022	R/L1, S/L2, T/L3, -, +1, +2, U/T1, V/T2, W/T3	M4	1.2 to 1.5	2 to 5.5	2	10
	⊕					
A4030	R/L1, S/L2, T/L3, -, +1, +2, U/T1, V/T2, W/T3	M4	1.2 to 1.5	2 to 5.5	2	20
	⊕				3.5	
A4040	R/L1, S/L2, T/L3, -, +1, +2, U/T1, V/T2, W/T3	M4	1.2 to 1.5	2 to 5.5	2	20
	⊕				3.5	

• Standard connections 3G3JV

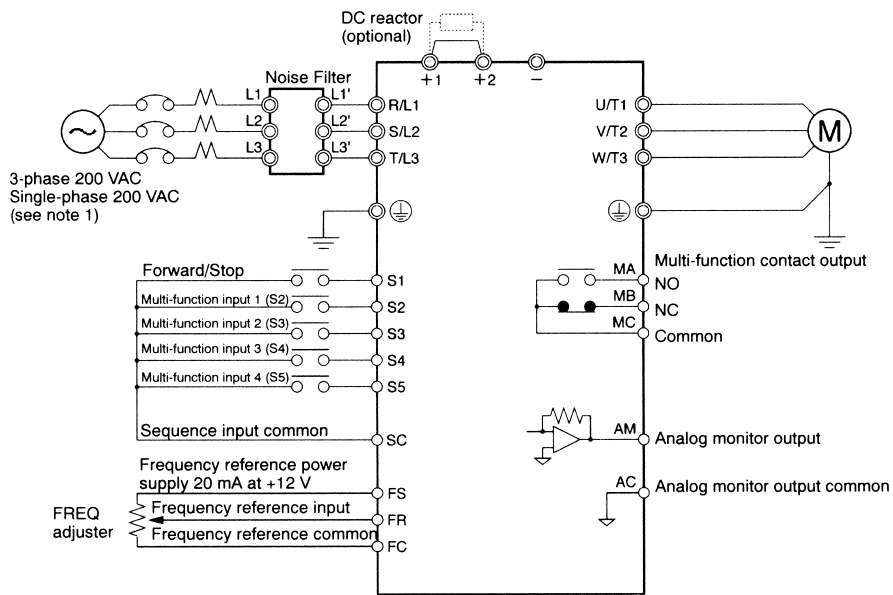

**Note 1.** Connect single-phase 200 VAC to terminals R/L1 and S/L2 of the 3G3JV-AB□.

**Note 2.** The braking resistor cannot be connected because no braking transistor is incorporated.

■ Wiring 3G3MV

• control circuit

Multi-function Contact Output (MA, MB, and MC)

Terminal screw size	Tightening torque N • m	Wire	Wire size mm <sup>2</sup> (AWG)	Recommended wire size mm <sup>2</sup> (AWG)	Cable
M3	0.5 to 0.6	Single wire	0.5 to 1.25 (20 to 16)	0.75 (18)	Cable with polyethylene sheath
		Stranded wire	0.5 to 1.25 (20 to 16)		

Sequential Input (S1 through S7 and SC), Multi-function Photocoupler Output (P1, P2, PC), RS-422/485 Communications (R+, R-, S+, S-) and Multi-function Analog Output (AM or AC), and Pulse Train Input (RP)

Terminal screw size	Tightening torque N • m	Wire	Wire size mm <sup>2</sup> (AWG)	Recommended wire size mm <sup>2</sup> (AWG)	Cable
M2	0.22 to 0.25	Single wire	0.5 to 1.25 (20 to 16)	0.75 (18)	Cable with polyethylene sheath
		Stranded wire	0.5 to 0.75 (20 to 18)		

Frequency Reference Input (FR, FS, and FC)

Terminal screw size	Tightening torque N • m	Wire	Wire size mm <sup>2</sup> (AWG)	Recommended wire size mm <sup>2</sup> (AWG)	Cable
M2	0.22 to 0.25	Single wire	0.5 to 1.25 (20 to 16)	0.75 (18)	Special cable with polyethylene sheath and shield for measurement use
		Stranded wire	0.5 to 0.75 (20 to 18)		

• 3-phase 200-VAC Model

Model 3G3MV-	Terminal symbol	Terminal screw	Screw tighten- ing torque (N•m)	Wire size (mm <sup>2</sup> )	Recom- mended wire size (mm <sup>2</sup> )	Molded case circuit breaker capacity (A)
A2001	R/L1, S/L2, T/L3, B1, B2, -, +1, +2, U/T1, V/T2, W/T3	M3.5	0.8 to 1.0	0.75 to 2	2	5
	⊕					
A2002	R/L1, S/L2, T/L3, B1, B2, -, +1, +2, U/T1, V/T2, W/T3	M3.5	0.8 to 1.0	0.75 to 2	2	5
	⊕					
A2004	R/L1, S/L2, T/L3, B1, B2, -, +1, +2, U/T1, V/T2, W/T3	M3.5	0.8 to 1.0	0.75 to 2	2	5
	⊕					
A2007	R/L1, S/L2, T/L3, B1, B2, -, +1, +2, U/T1, V/T2, W/T3	M3.5	0.8 to 1.0	0.75 to 2	2	10
	⊕					
A2015	R/L1, S/L2, T/L3, B1, B2, -, +1, +2, U/T1, V/T2, W/T3	M4	1.25 to 1.5	2 to 5.5	2	20
	⊕				3.5	
A2022	R/L1, S/L2, T/L3, B1, B2, -, +1, +2, U/T1, V/T2, W/T3	M4	1.2 to 1.5	2 to 5.5	3.5	20
	⊕					
A2040	R/L1, S/L2, T/L3, B1, B2, -, +1, +2, U/T1, V/T2, W/T3	M4	1.2 to 1.5	2 to 5.5	5.5	30
	⊕					
A2055	R/L1, S/L2, T/L3, B1, B2, -, +1, +2, U/T1, V/T2, W/T3	M5	2.5	5.5 to 8	8	50
	⊕					
A2075	R/L1, S/L2, T/L3, B1, B2, -, +1, +2, U/T1, V/T2, W/T3	M5	2.5	5.5 to 8	8	50
	⊕					

### Single-phase 200-VAC Model

Model 3G3MV-	Terminal symbol	Terminal screw	Terminal torque (N•m)	Wire size (mm <sup>2</sup> )	Recom- mended wire size (mm <sup>2</sup> )	Circuit breaker capacity (A)
AB001	R/L1, S/L2, T/L3, B1, B2, -, +1, +2, U/T1, V/T2, W/T3	M3.5	0.8 to 1.0	0.75 to 2	2	5
	⊕					
AB002	R/L1, S/L2, T/L3, B1, B2, -, +1, +2, U/T1, V/T2, W/T3	M3.5	0.8 to 1.0	0.75 to 2	2	5
	⊕					
AB004	R/L1, S/L2, T/L3, B1, B2, -, +1, +2, U/T1, V/T2, W/T3	M3.5	0.8 to 1.0	0.75 to 2	2	10
	⊕					
AB007	R/L1, S/L2, T/L3, B1, B2, -, +1, +2, U/T1, V/T2, W/T3	M4	1.2 to 1.5	2 to 5.5	3.5	20
	⊕				2	
AB015	R/L1, S/L2, T/L3, B1, B2, -, +1, +2, U/T1, V/T2, W/T3	M4	1.2 to 1.5	2 to 5.5	5.5	20
	⊕				3.5	
AB022	R/L1, S/L2, T/L3, B1, B2, -, +1, +2, U/T1, V/T2, W/T3	M4	1.2 to 1.5	2 to 5.5	5.5	40
	⊕					
AB040	R/L1, S/L2, T/L3, B1, B2, -, +1, +2, U/T1, V/T2, W/T3	M5	2.3 to 2.4	5.5 to 8	8	50
	⊕	M4	1.2 to 2.5	2 to 8	5.5	

### 3-phase 400-VAC Model

Model 3G3MV-	Terminal symbol	Terminal screw	Screw tighten- ing torque (N•m)	Wire size (mm <sup>2</sup> )	Recom- mended wire size (mm <sup>2</sup> )	Molded- case circuit breaker capacity (A)
A4002	R/L1, S/L2, T/L3, B1, B2, -, +1, +2, U/T1, V/T2, W/T3	M4	1.2 to 1.5	2 to 5.5	2	5
	⊕					
A4004	R/L1, S/L2, T/L3, B1, B2, -, +1, +2, U/T1, V/T2, W/T3	M4	1.2 to 1.5	2 to 5.5	2	5
	⊕					
A4007	R/L1, S/L2, T/L3, B1, B2, -, +1, +2, U/T1, V/T2, W/T3	M4	1.2 to 1.5	2 to 5.5	2	5
	⊕					
A4015	R/L1, S/L2, T/L3, B1, B2, -, +1, +2, U/T1, V/T2, W/T3	M4	1.2 to 1.5	2 to 5.5	2	10
	⊕					
A4022	R/L1, S/L2, T/L3, B1, B2, -, +1, +2, U/T1, V/T2, W/T3	M4	1.2 to 1.5	2 to 5.5	2	10
	⊕					
A4030	R/L1, S/L2, T/L3, B1, B2, -, +1, +2, U/T1, V/T2, W/T3	M4	1.2 to 1.5	2 to 5.5	2	20
	⊕				3.5	
A4040	R/L1, S/L2, T/L3, B1, B2, -, +1, +2, U/T1, V/T2, W/T3	M4	1.2 to 1.5	2 to 5.5	2	20
	⊕				3.5	

Model 3G3MV-	Terminal symbol	Terminal screw	Screw tighten- ing torque (N•m)	Wire size (mm <sup>2</sup> )	Recom- mended wire size (mm <sup>2</sup> )	Molded- case circuit breaker capacity (A)
A4055	R/L1, S/L2, T/L3, B1, B2, -, +1, +2, U/T1, V/T2, W/T3	M4	1.8	5.5	5.5	30
	⊕					
A4075	R/L1, S/L2, T/L3, B1, B2, -, +1, +2, U/T1, V/T2, W/T3	M5	1.8	5.5 to 8	5.5	30
	⊕					

• Standard Connections 3G3MV

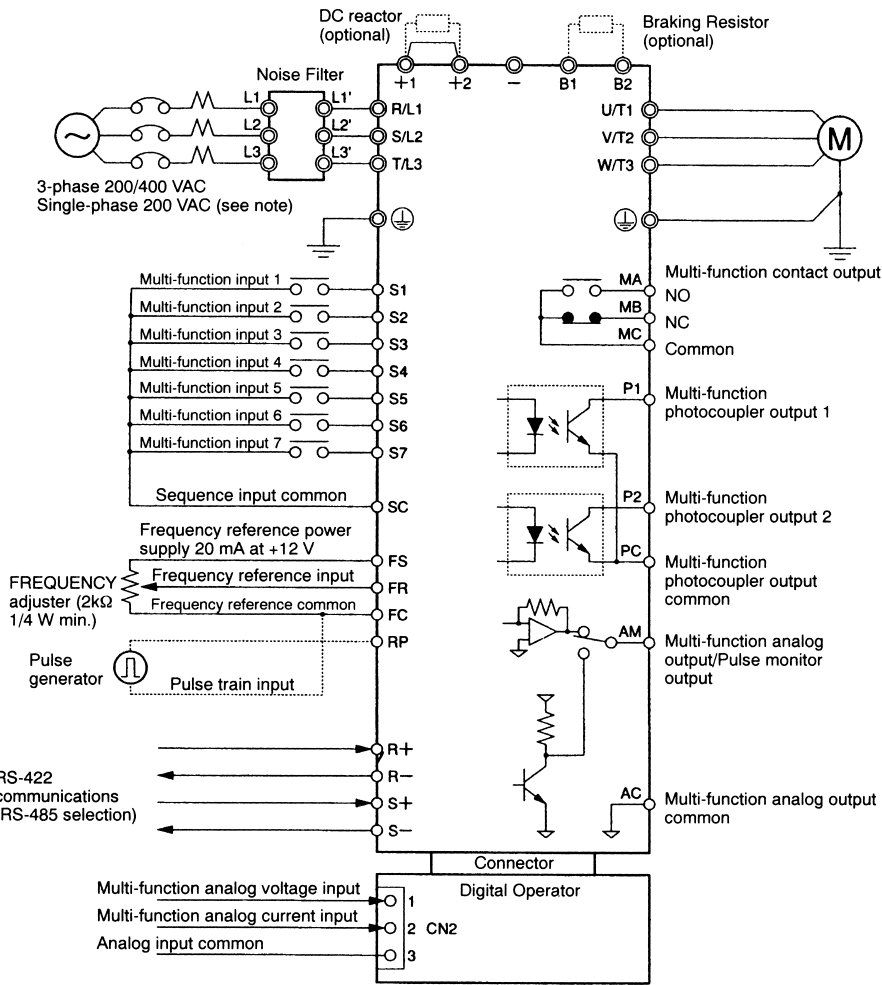

**Note** Connect single-phase 200 VAC to terminals R/L1 and S/L2 of the 3G3MV-AB□.

## ■ Motor Protection Settings 3G3JV

### Rated motor current (n32)

Set the rated motor current (n32) in order to prevent the motor from burning due to overloading.

Check the rated current on the motor nameplate and set the parameter.

This parameter is used for the electronic thermal function for motor overload detection (OL1). By setting the correct parameter, the overloaded motor will be protected from burning.

n32	<b>Rated Motor Current</b>			<b>Changes during operation</b>	No
<b>Setting range</b>	0.0% to 120% (A) of rated output current of Inverter	<b>Unit of setting</b>	0.1 A	<b>Default setting</b>	(see note 1)

**Note 1.** The standard rated current of the maximum applicable motor is the default rated motor current.

**Note 2.** Motor overload detection (OL1) is disabled by setting the parameter to 0.0.

### Motor Protection Characteristics (n33 and n34)

• This parameter setting is for motor overload detection (OL1).

n33	<b>Motor Protection Characteristic Selection</b>			<b>Changes during operation</b>	No
Setting range	0 to 2	<b>Unit of setting</b>	1	<b>Default setting</b>	0

#### Set Values

Value	Description
0	Protection characteristics for general-purpose induction motors
1	Protection characteristics for Inverter-dedicated motors
2	No protection

- This parameter is used to set the electric thermal characteristics of the motor to be connected.
- Set the parameter according to the motor.
- If a single Inverter is connected to more than one motor, set the parameter to 2 for no protection. The parameter is also disabled by setting n32 for rated motor current to 0.0.

n34	<b>Motor Protection Time</b>			<b>Changes during operation</b>	No
<b>Setting range</b>	1 to 60 (min)	<b>Unit of setting</b>	1 min	<b>Default setting</b>	8

## ■ Motor Protection Settings 3G3MV

### Rated motor current (n36)

- Check the motor nameplate and set this parameter to the rated current.
- This parameter is used as a vector control constant. Be sure to set the parameter correctly. This set value is also used for determining the electronic thermal characteristics to protect the motor from overheating. The correct set value protects the motor from burning that may result from overloading.

n036	<b>Rated Motor Current</b>	<b>Register</b>	0124 Hex	<b>Changes during operation</b>	No
<b>Setting range</b>	0.0% to 150% (A) of rated output current of the Inverter	<b>Unit of setting</b>	0.1 A	<b>Default setting</b>	See note

**Note** The default setting for this parameter is the standard rated current of the maximum applicable motor.

### Motor Protection Functions (n037 and n038)

- This parameter setting is for motor overload detection (OL1).

n037	<b>Motor Protection Characteristics</b>	<b>Register</b>	0125 Hex	<b>Changes during operation</b>	No
<b>Setting range</b>	0 to 2	<b>Unit of setting</b>	1	<b>Default setting</b>	0

**Note** The default setting for this parameter is the standard rated current of the maximum applicable motor.

#### Set Values

Value	Description
0	Protection characteristics for general-purpose induction motors
1	Protection characteristics for Inverter-dedicated motors
2	No protection

- This parameter is used to set the electric thermal characteristics of the motor to be connected.
- Set the parameter according to the motor.
- If a single Inverter is connected to more than one motor, set the parameter to 2 for no protection. The parameter is also disabled by setting n36 for rated motor current to 0.0.

n038	<b>Motor Protection Time</b>	<b>Register</b>	0126 Hex	<b>Changes during operation</b>	No
<b>Setting range</b>	1 to 60 (min)	<b>Unit of setting</b>	1 min	<b>Default setting</b>	8

#### Set values

- This parameter is used to set the electronic thermal protection constant of motor overload detection OL1.
- The default setting does not need any changes in normal operation.
- To set the parameter according to the characteristics of the motor, confirm the thermal time constant with the motor manufacturer and set the parameter with some margin. In other words, set the value a little shorter than the thermal time constant.
- To detect motor overloading more quickly, reduce the set value, provided that it does not cause any application problems.



# DIMENSIONS

Table 2 3G3MV Finless Dimensions in mm (inches) / Mass in kg (lb)

Voltage class	Model	W	H	D	W1	H1	H2	d	t	Mass	fig.
200 V three phase	A2001	68 (2.68)	128 (5.04)	71 (2.82)	56 (2.20)	118 (4.65)	5 (0.20)	M4	5 (0.20)	0.6 (1.32)	2
	A2002	68 (2.68)	128 (5.04)	71 (2.82)	56 (2.20)	118 (4.65)	5 (0.20)	M4	5 (0.20)	0.6 (1.32)	2
	A2004	68 (2.68)	128 (5.04)	71 (2.82)	56 (2.20)	118 (4.65)	5 (0.20)	M4	5 (0.20)	0.7 (1.54)	2
	A2007	68 (2.68)	128 (5.04)	71 (2.82)	56 (2.20)	118 (4.65)	5 (0.20)	M4	5 (0.20)	0.8 (1.76)	2
	A2015	108 (4.25)	128 (5.04)	73 (2.87)	96 (3.78)	118 (4.65)	5 (0.20)	M4	6 (0.24)	0.9 (1.98)	3
	A2022	108 (4.25)	128 (5.04)	82 (3.23)	96 (3.78)	118 (4.65)	5 (0.20)	M4	6 (0.24)	1.0 (2.20)	3
	A2040	140 (5.51)	128 (5.04)	78 (3.07)	128 (5.04)	118 (4.65)	5 (0.20)	M4	6 (0.24)	1.2 (2.64)	4
	A2055	180 (7.09)	260 (10.24)	125 (4.92)	164 (6.46)	244 (9.61)	8 (0.31)	M5	10 (0.39)	5.2 (0.20)	5
	A2075	180 (7.09)	260 (10.24)	125 (4.92)	164 (6.46)	244 (9.61)	8 (0.31)	M5	10 (0.39)	5.4 (0.21)	5
200 V single phase	AB001	68 (2.68)	128 (5.04)	71 (2.82)	56 (2.20)	118 (4.65)	5 (0.20)	M4	5 (0.20)	0.6 (1.32)	2
	AB002	68 (2.68)	128 (5.04)	71 (2.82)	56 (2.20)	118 (4.65)	5 (0.20)	M4	5 (0.20)	0.7 (1.54)	2
	AB004	68 (2.68)	128 (5.04)	94 (3.70)	56 (2.20)	118 (4.65)	5 (0.20)	M4	5 (0.20)	0.8 (1.76)	2
	AB007	108 (4.25)	128 (5.04)	82 (3.23)	96 (3.78)	118 (4.65)	5 (0.20)	M4	6 (0.24)	1.0 (2.20)	3
	AB015	108 (4.35)	128 (5.04)	98 (3.86)	96 (3.78)	118 (4.65)	5 (0.20)	M4	6 (0.24)	1.0 (2.20)	3
	AB022	140 (5.51)	128 (5.04)	98 (3.86)	128 (5.04)	118 (4.65)	5 (0.20)	M4	6 (0.24)	1.3 (2.86)	4
	AB040	170 (6.69)	128 (5.04)	119 (4.69)	158 (6.22)	118 (4.65)	5 (0.20)	M4	10 (0.39)	2.0 (4.40)	6

Voltage class	Model	W	H	D	W1	H1	H2	d	t	Mass	fig.
400 V three phase	A4002	108 (4.25)	128 (5.04)	82 (3.23)	96 (3.78)	118 (4.65)	5 (0.20)	M4	6 (0.24)	0.9 (1.98)	3
	A4004	108 (4.25)	128 (5.04)	82 (3.23)	96 (3.78)	118 (4.65)	5 (0.20)	M4	6 (0.24)	0.9 (1.98)	3
	A4007	108 (4.25)	128 (5.04)	82 (3.23)	96 (3.78)	118 (4.65)	5 (0.20)	M4	6 (0.24)	1.0 (2.20)	3
	A4015	108 (4.25)	128 (5.04)	98 (3.86)	96 (3.78)	118 (4.65)	5 (0.20)	M4	6 (0.24)	1.0 (2.20)	3
	A4022	108 (4.25)	128 (5.04)	98 (3.86)	96 (3.78)	118 (4.65)	5 (0.20)	M4	6 (0.24)	1.0 (2.20)	3
	A4030	140 (5.51)	128 (5.04)	78 (3.07)	128 (5.04)	118 (4.65)	5 (0.20)	M4	6 (0.24)	1.2 (2.65)	4
	A4040	140 (5.51)	128 (5.04)	78 (3.07)	128 (5.04)	118 (4.65)	5 (0.20)	M4	6 (0.24)	1.2 (2.65)	4
	A4055	180 (7.09)	260 (10.24)	125 (4.92)	164 (6.46)	244 (9.61)	8 (0.31)	M5	10 (0.39)	5.4 (0.21)	5
	A4075	180 (7.09)	260 (10.24)	125 (4.92)	164 (6.46)	244 (9.61)	8 (0.31)	M5	10 (0.39)	5.4 (0.21)	5

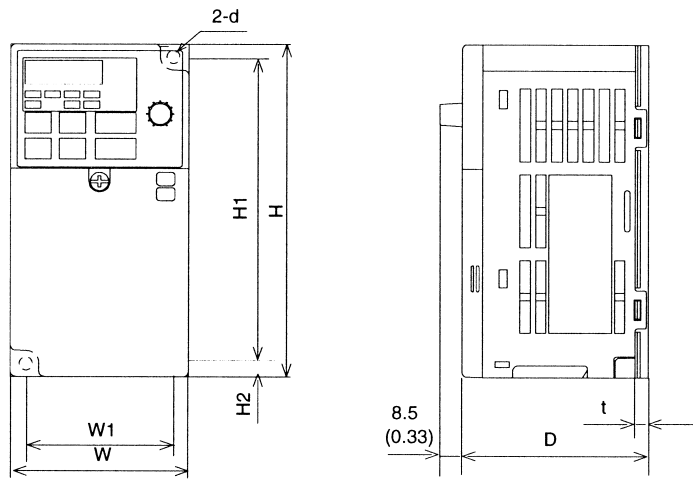

Fig. 2

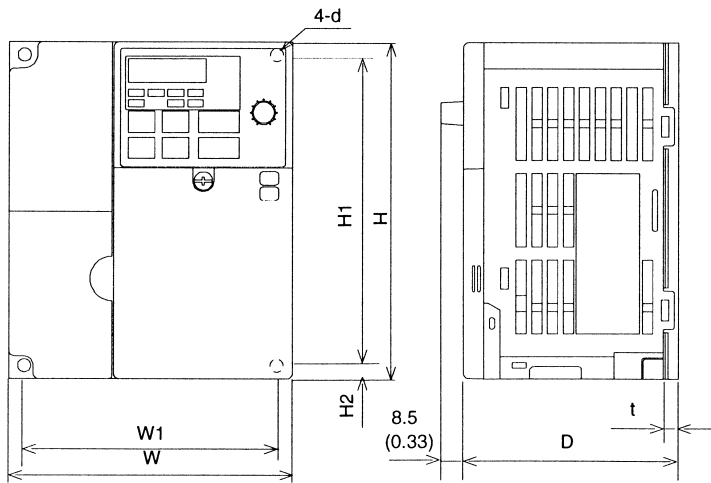

Fig. 3

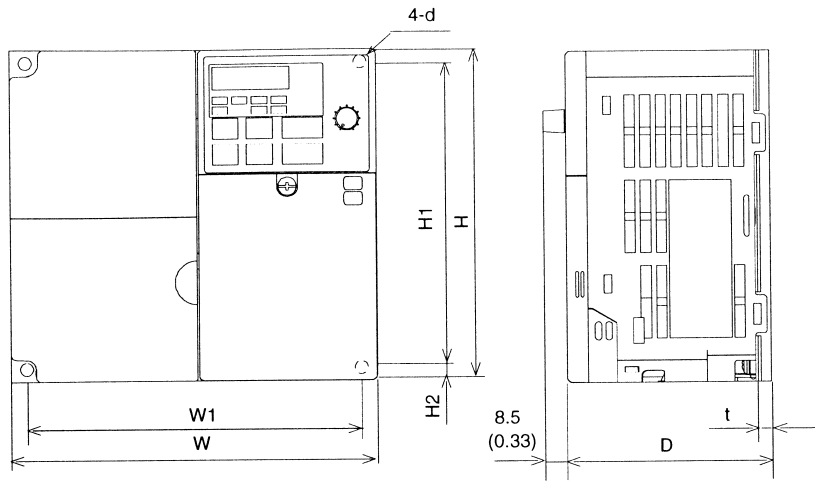

Fig. 4

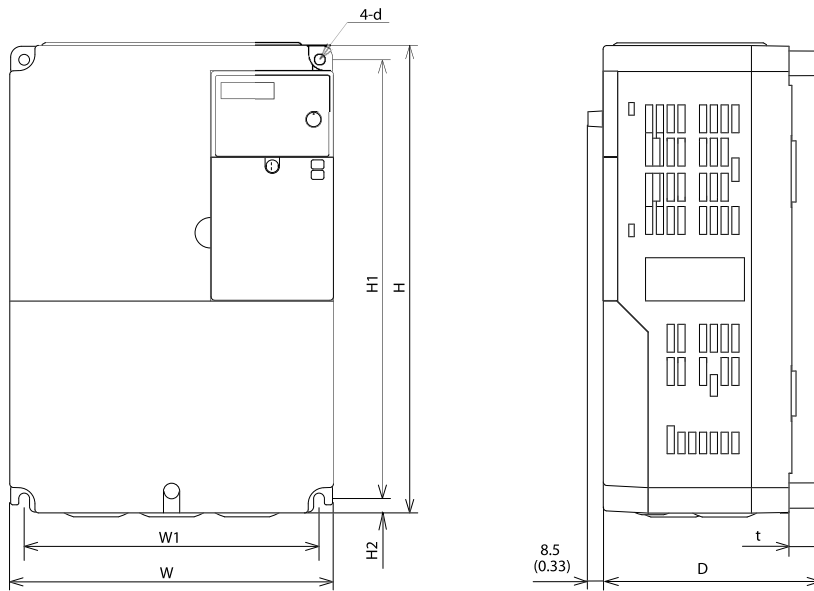

Fig. 5

Table 3 3G3JV Finless Dimensions in mm (inches) / Mass in kg (lb)

Voltage class	Model	W	H	D	W1	H1	H2	d	t	Mass	fig.
200 V three phase	A2001	68 (2.68)	128 (5.04)	65 (2.56)	56 (2.20)	118 (4.65)	5 (0.20)	M4	5 (0.20)	0.5 (1.10)	7
	A2002	68 (2.68)	128 (5.04)	65 (2.56)	56 (2.20)	118 (4.65)	5 (0.20)	M4	5 (0.20)	0.5 (1.10)	7
	A2004	68 (2.68)	128 (5.04)	65 (2.56)	56 (2.20)	118 (4.65)	5 (0.20)	M4	5 (0.20)	0.6 (1.32)	7
	A2007	68 (2.68)	128 (5.04)	65 (2.56)	56 (2.20)	118 (4.65)	5 (0.20)	M4	5 (0.20)	0.6 (1.32)	7
	A2015	108 (4.25)	128 (5.04)	71 (2.82)	96 (3.78)	118 (4.65)	5 (0.20)	M4	6 (0.24)	0.8 (1.76)	8
	A2022	108 (4.25)	128 (5.04)	96 (3.78)	96 (3.78)	118 (4.65)	5 (0.20)	M4	6 (0.24)	1.0 (2.20)	8
	A2040	140 (5.51)	128 (5.04)	96 (3.78)	128 (5.04)	118 (4.65)	5 (0.20)	M4	6 (0.24)	1.2 (2.64)	9
200 V single-phase	AB001	68 (2.68)	128 (5.04)	65 (2.56)	56 (2.20)	118 (4.65)	5 (0.20)	M4	5 (0.20)	0.5 (1.10)	7
	AB002	68 (2.68)	128 (5.04)	65 (2.56)	56 (2.20)	118 (4.65)	5 (0.20)	M4	5 (0.20)	0.5 (1.10)	7
	AB004	68 (2.68)	128 (5.04)	75 (2.95)	56 (2.20)	118 (4.65)	5 (0.20)	M4	5 (0.20)	0.7 (1.54)	7
	AB007	108 (4.25)	128 (5.04)	71 (2.82)	96 (3.78)	118 (4.65)	5 (0.20)	M4	6 (0.24)	0.9 (1.98)	8
	AB015	108 (4.25)	128 (5.04)	96 (3.78)	96 (3.78)	118 (4.65)	5 (0.20)	M4	6 (0.24)	1.0 (2.20)	8
400 V three phase	A4002	108 (4.25)	128 (5.04)	71 (2.82)	96 (3.78)	118 (4.65)	5 (0.20)	M4	6 (0.24)	0.9 (1.98)	8
	A4004	108 (4.25)	128 (5.04)	71 (2.82)	96 (3.78)	118 (4.65)	5 (0.20)	M4	6 (0.24)	0.9 (1.98)	8
	A4007	108 (4.25)	128 (5.04)	71 (2.82)	96 (3.78)	118 (4.65)	5 (0.20)	M4	6 (0.24)	1.0 (2.20)	8
	A4015	108 (4.25)	128 (5.04)	96 (3.78)	96 (3.78)	118 (4.65)	5 (0.20)	M4	6 (0.24)	1.0 (2.20)	8
	A4022	108 (4.25)	128 (5.04)	96 (3.78)	96 (3.78)	118 (4.65)	5 (0.20)	M4	6 (0.24)	1.0 (2.20)	8
	A4030	140 (5.51)	128 (5.04)	96 (3.78)	128 (5.04)	118 (4.65)	5 (0.20)	M4	6 (0.24)	1.2 (2.64)	9
	A4040	140 (5.51)	128 (5.04)	96 (3.78)	128 (5.04)	118 (4.65)	5 (0.20)	M4	6 (0.24)	1.2 (2.64)	9

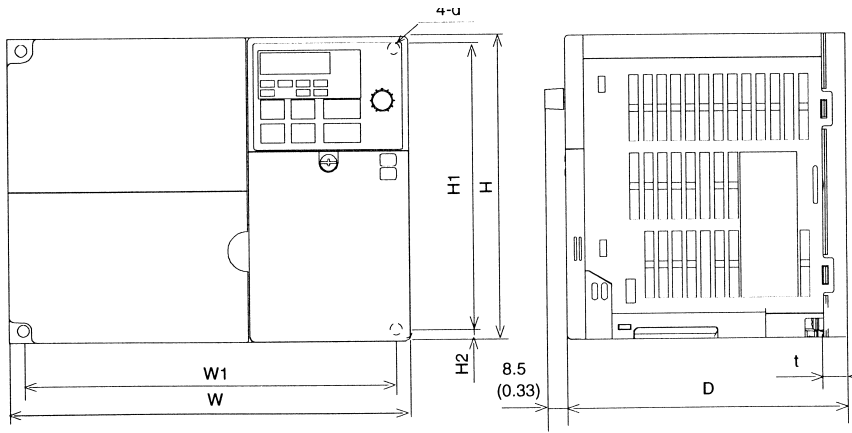

Fig.6

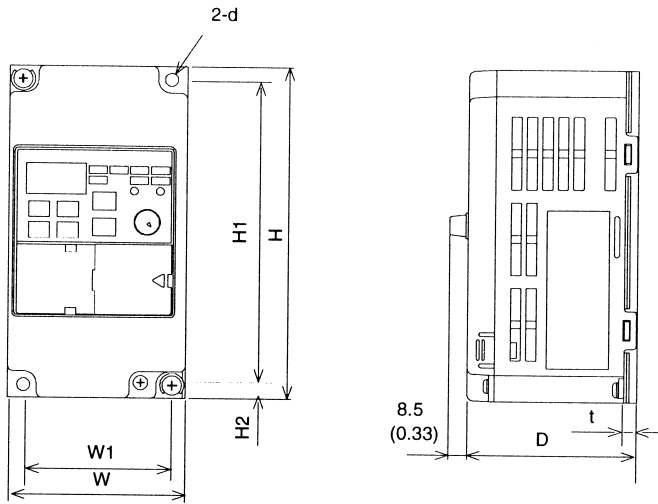

Fig. 7

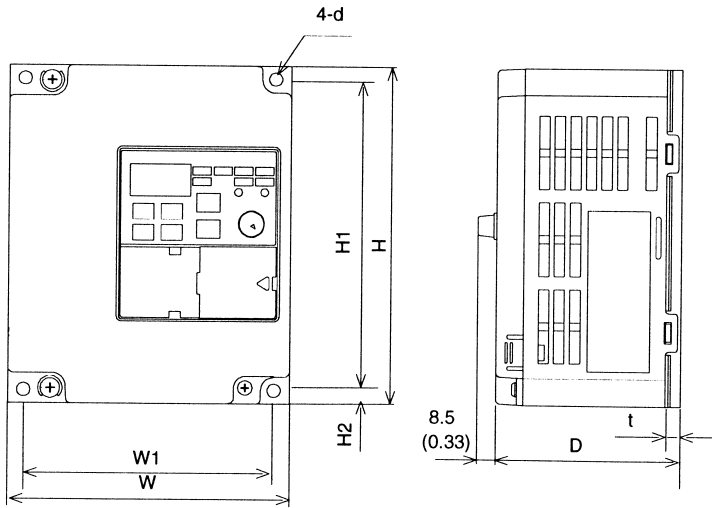

Fig. 8

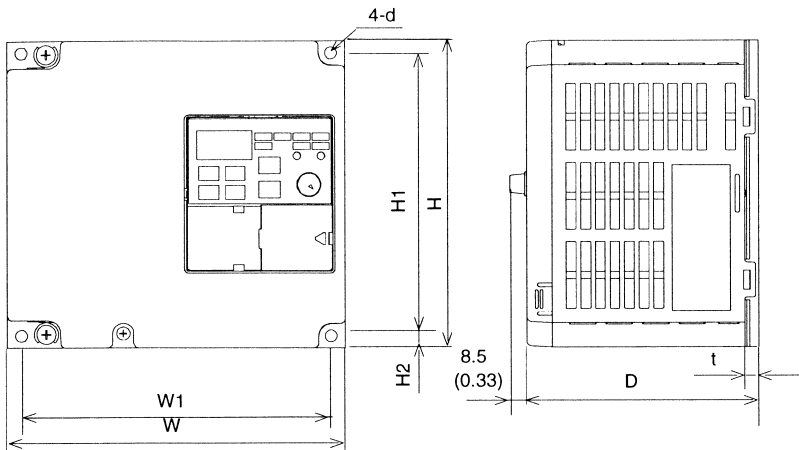

Fig. 9