

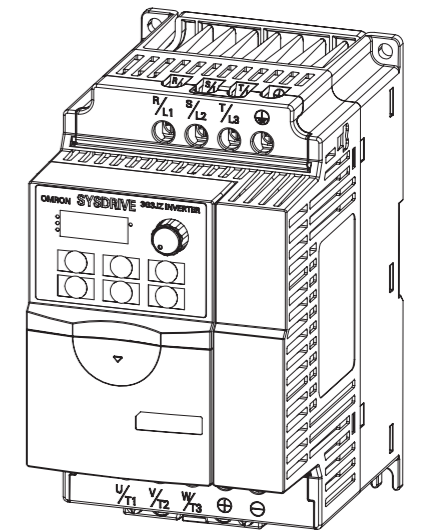

## USER'S MANUAL



### Intelligent Easy-to-use Inverter **SYSDRIVE** 3G3JZ Series

OMRON Industrial Automation Business Group(China)

Cat. No. I557-E5-03

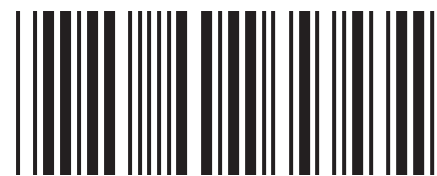

# Safety Precautions

- To use OMRON inverter products safely and correctly, please read "Safety Precautions" carefully before using.  
Use the product with device knowledge, safety information and precautions clearly remembered.
- The final user of this product must have this manual.
- Please take this manual with you for looking up.

- The precautions here are very important information used to ensure safety, please observe it.
- Details and meanings are as below.

 <b>Danger</b>	Incorrect operation may cause danger, result in serious injury or death.
---	--

 <b>Caution</b>	Incorrect operation may cause danger, result in minor or moderate injury and may damage the device.
--	---

In addition, not observing may result in unrecorded serious consequence.

## Mark Explanation



◇ indicates danger, △ indicates caution.  
For details please refer to the explanation inside or nearby the marks.  
Eg. Left diagram indicates "danger of electric shock"













⊘ indicates a prohibited (unpermissible) operation.  
For details please refer to the explanation inside or nearby the marks.  
Eg. Left diagram indicates "disassembly prohibited"



● indicates a regulation (must be observed).  
For details please refer to the explanation inside or nearby the marks.  
Eg. Left diagram indicates "must be grounded"

- For explain in detail, the diagrams in the manual may be without case or safety devices, please install the case and safety devices according to the regulation in this manual.
- If you need a longterm storage, please contact with OMRON representative.

## Safety Precautions

 <b>Caution</b>	
<p>Please ground the inverter. Not doing so may occasionally result in serious injury due to electric shock.</p>	
<p>Provide an external emergency stopping device that allows an instantaneous stop of operation and power interruption. In addition, please confirm that the emergency braker is operating normally, to avoid minor injuries.</p>	
<p>The heat generated by braking unit/braking resistor may occasionally result in moderate scald. Please use specified braking unit/braking resistor, and mount a thermal relay on braking resistor to monitor any fault. In addition, sequence must be set, so it can cut the power of inverter when braking unit/braking resistor is faulty.</p>	
<p>Do not open terminal case when power is being supplied or power has just been turned OFF for less than 10 minutes. Doing so may occasionally result in minor injury due to electric shock.</p>	
<p>Do not touch the radiating fan when power is being supplied or power has just been turned OFF for a short period. Doing so may occasionally result in scald due to high temperature.</p>	
<p>Short is load wiring may damage the unit. As a safety countermeasure, always connect the Inverter and power supply via a molded case circuit breaker (MCCB) suitable to the Inverter for protecting the Inverter from damage that may result from short-circuiting.</p>	
<p>Precautions on the dangers of high-voltage equipment. Place a cover over the Inverter during installation to shield it from metal powder produced by drilling.</p>	
<p>Terminal +/B1, B2 and — are used to connect braking unit/braking resistor, please do not connect any other device. Doing so may result in minor burning, heating, or damage the device.</p>	
<p>Do not disassemble and modify the inverter. Doing so may occasionally result in serious injury due to electric shock.</p>	

## Safety Precautions

- (1) About setting and storing environment  
Do not store or operate the product in the following places.
1. Locations subject to direct sunlight.
  2. Locations subject to temperatures outside the range specified in the specifications.  
Ambient operating temperature: -10 °C ~ +50 °C  
(close mounting: -10 °C ~ +40 °C)
  3. Locations subject to humidity outside the range specified in the specifications.  
Ambient operating humidity: relative humidity 90 % max
  4. Locations subject to condensation as the result of severe changes in temperature.
  5. Locations subject to corrosive or flammable gases.
  6. Locations subject to exposure to combustibles.
  7. Locations subject to dust (especially iron dust) or salts.
  8. Locations subject to exposure to water, oil, or chemicals.
  9. Locations subject to shock or vibration.
- (2) About transmission, setting and wiring
1. Use specified package when transmitting the product.
  2. Prevent shock and dropping. Doing so may result in damage to the product or malfunction.
  3. Do not connect an AC power supply to output U/T1, V/T2 and W/T3 terminals, doing so may damage the product.
  4. Do not connect a load other than 3-phase motor to output terminals (U/T1, V/T2 and W/T3).
  5. Do not connect an AC power supply to control I/O terminals other than relay output, doing so may damage the product.
  6. Use 600 V insulated cable with specified diameter for main circuit terminal wiring. In addition, secure the terminal block bolts to the torque specified according to inverter power.
  7. Take sufficient shelter countermeasures in following locations.
    - Noise caused by static electric
    - Near strong magnetic field
    - Near power cable
- (3) About operation and maintenance
1. This product can be set from low speed to high speed, please check the permissible range of the motor device being used before operating.
  2. To avoid dropping of the vertical load, please confirm the operation after setting and wiring before using external braker output. Doing so may occasionally result in minor injury.
  3. Ensure safety when performing maintenance, inspection and part replacement.

## Precautions

- (1) About installation  
Installing orient is vertical wall installation.  
The inverter should be in a specified distance from the inside of control panel and other devices, the distance corresponds to inverter's power.
- (2) About main circuit power supply:  
Power supply used by inverters:
- Single-phase 200V 200 ~ 240VAC 50/60Hz
  - 3-phase 200V 200 ~ 240VAC 50/60Hz
  - 3-phase 400V 380 ~ 480VAC 50/60Hz
- (3) About the operation after resetting from momentary power OFF  
If you select continue operating in Operation Selection after Momentary Rest (n8.04), The inverter will restart suddenly after the power is reset. Please pay attention.
- (4) About operation command selection  
In following cases, unexpected operation may take place in the motor, please perform after ensuring the security.
- Operation command selection (n2.01) is set to control circuit terminal, operation selection after power supply putting in/operation command switching (n2.05) is set to enable, turn ON the power when there are operation signals.
  - Multi-function input (n4.05 to n4.08) is set to operation command switch, operation selection after power supply putting in/operation command switching (n2.05) is set to enable, switch to other operation commands when there are some operation signals.
  - Fault retry times (n8.15) is set to enable, auto resetting from faulty stop.
  - Verify the signal when power is being supplied, apply an incorrect voltage to control input terminal.
- (5) About motor heating protection (electrical thermal)  
To protect the motor from overheated, the inverter has a protect function through electrical thermal. Please input rated current of the motor being used to Motor Rated Current (n7.00). In addition, when running multiple motors from 1 inverter, the protect function provided by electric thermal is not enough to protect the motor from overheated. In such case, you can set Motor Protect Function Selection (n6.06) to disable motor overload protection, and mount thermal relays among the inverter and the motors. Please set thermal relay to 1.0 times the current on nameplate in 50 Hz, 1.1 times in 60 Hz.
- (6) Disuse of the product  
Disuse the product according to related regulations.

# Safety Precautions

## Precautions on compliance with EMC directive

This is a class A (Category C3) product designed for industrial environment. Use in residential area may cause radio interference, in which case the user may be required to take adequate measures to reduce interference.

### ■ Warning Indication

The following diagram shows the location of precautions.

Please observe it when using the product.

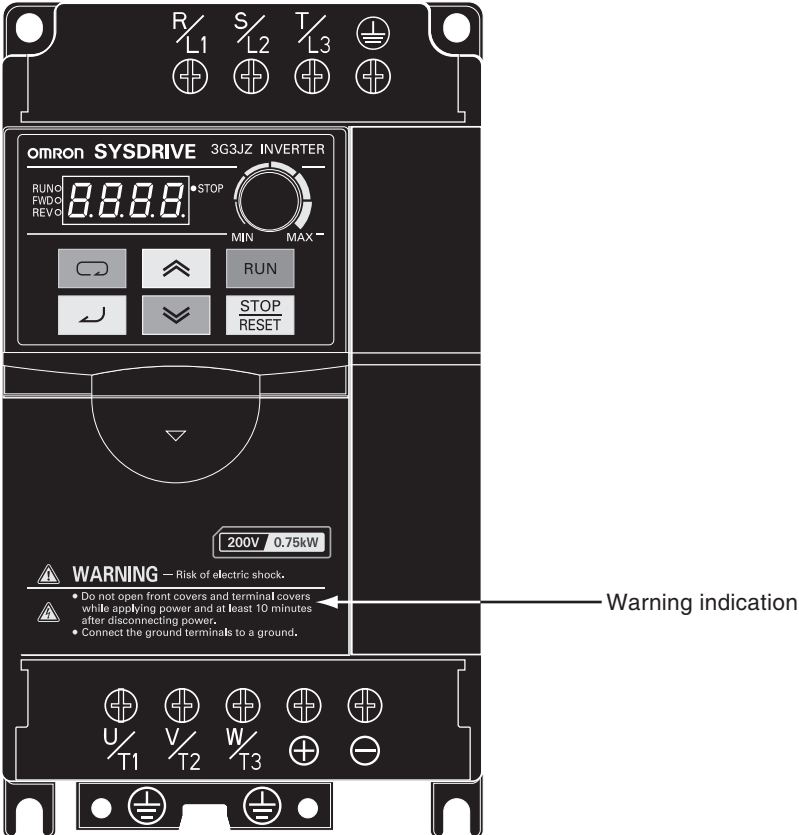

## ■Warranty and Limitations of Liability

### WARRANTY TERM

OMRON's exclusive warranty is that the products are free from defects in materials and workmanship for a period of one year from date of sale by OMRON, or 18 months from shipping, which is shorter.

### WARRANTY RANGE

#### Fault Diagnosis

Fault diagnosis is performed by customer in principle.

However, if you request, OMRON or our service network can provide a charged service.

In this case, according to the discussion result, if we are the one to fulfill the responsibility, the service will be free.

#### Fault repair

If the product needs to be repaired or replaced, we will provide a free visiting service.

The following cases are charged services.

- The faults are caused by incorrect storage and use, lapse or design.
- Privately modify this product without informing us.
- The faults are caused because the product is used outside the specifications.
- The faults are caused by natural disaster or fire.
- Other reasons which are not on our liability.

Above free services are only faced with Chinese domestic users. To the Chinese abroad users, we offer a reasonable charged service.

## ■Outside the Warranty

Inconvenience and damage of other products caused by OMRON product's fault, are not included in the warranty, regardless of whether in the warranty term.

## ■Suitability for Use

- Systems, machines, and equipment that could present a risk to life.
- If you need to use this product in inhabited moving object, medical, aerospace, nuclear energy, electrical, benthal transfer communication devices or system, please contact with OMRON representative.

This product is produced under a rigorous management, however, if the fault of this product may cause serious incident or property loss, please use security devices.

# Checking Before Unpacking

## ■ Checking the Product

On delivery, always check that the delivered product is the SYSDRIVE 3G3MZ Inverter that you ordered.

Should you find any problems with the product, immediately contact your nearest local sales representative.

## ● Checking the Nameplate

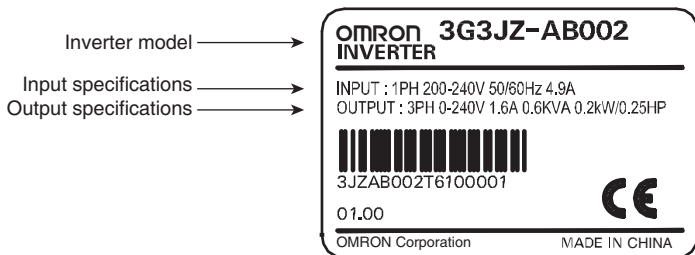

## ● Checking the model

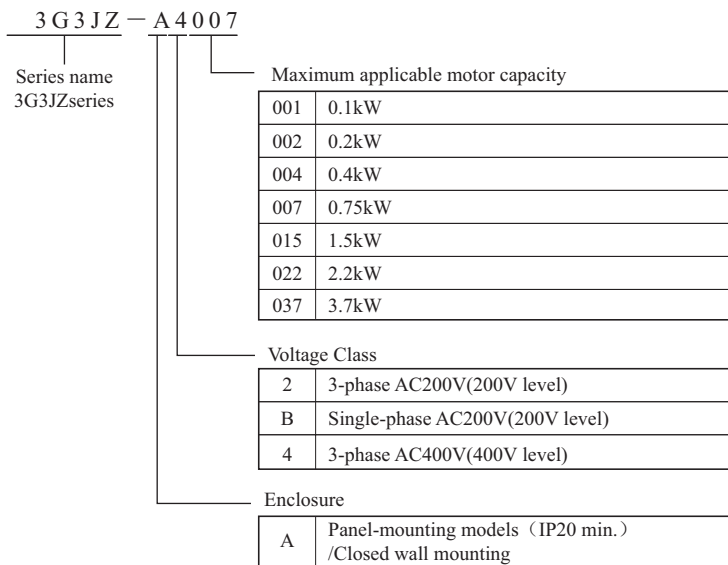

## ■ Checking the Accessories

"Safety Precautions" is the only accessory provided with the 3G3MZ.

Set screws and other necessary parts must be provided by the user.

■ This manual consists of the following contents, as required by customers.

Please read and understand the manual before use.

## Chapter 1 Overview

Characteristic and nomenclature of the product.

## Chapter 2 Design

External dimensions, mounting dimensions and option design/purchasing required in design.

## Chapter 3 Operation • Monitoring

Nomenclature, key operation of Digital Operator and operation method of the product.

## Chapter 4 Test Run

After confirming the product and user system, first run the motor using frequency adjuster on the front of the product.

## Chapter 5 Basic Operation

A description of inverter's normal control functions and functions must be discussed and set when using inverter's driving motor, prepared for first-time users.

## Chapter 6 Advanced Operation

All functions which can be attached are described here, prepared for further users. Responsiveness (torque characteristic), speed/precision increasing, stall prevention and overtorque detection used to increase inverter's control ability to motors, are described here.

## Chapter 7 Communications

Description of common series communication function (RS-485 communication) and records of connection methods and program examples of SYSMAC protocol macro.

## Chapter 8 Application

Description of inverter maintenance.  
Cause analyzing and remedy of inverter faulty status, malfunction which may happen and remedy (injection), periodical injection.

## Chapter 9 Specifications

Inverter specifications and specifications/external dimensions of options.

## Chapter 10 List of Parameters

Parameter setting records for users who use the product frequently and have a grip of it. Parameter confirmations such as adjusting are arranged in sequence, for lookup. In addition, refer to detailed function descriptions in reference column when you want to confirm function details again.

# Contents

---

<b>Chapter 1</b>	<b>Overview</b>
1-1	Functions ..... 1-1
1-2	Nomenclature ..... 1-3
<b>Chapter 2</b>	<b>Design</b>
2-1	Installation ..... 2-1
2-2	Wiring ..... 2-5
<b>Chapter 3</b>	<b>Operation • Monitoring</b>
3-1	Operation for Digital Operator ..... 3-1
3-2	Monitor Function of Digital Operator ..... 3-5
<b>Chapter 4</b>	<b>Test Run</b>
4-1	Procedure for Test Run ..... 4-2
4-2	Operation for Test Run ..... 4-3
<b>Chapter 5</b>	<b>Basic Operation</b>
5-1	Initial Settings ..... 5-1
5-2	Operation in V/f Control ..... 5-2
5-3	Selecting the Operation Command ..... 5-4
5-4	Setting the Frequency Command ..... 5-6
5-5	Setting the Acceleration/Deceleration Time ..... 5-14
5-6	Selecting the Reverse Rotation-prohibit ..... 5-16
5-7	Selecting the Stopping Method ..... 5-16
5-8	Multi-function I/O ..... 5-17
5-9	Multi-function Analog Output ..... 5-21
<b>Chapter 6</b>	<b>Advanced Operation</b>
6-1	Slip Compensation Function ..... 6-1
6-2	Torque Compensation Function ..... 6-2
6-3	Setting the Carrier Frequency ..... 6-3
6-4	Energy Saving Control ..... 6-4
6-5	Input Terminal Setting Function ..... 6-4
6-6	External Stopper Operation Time Function ..... 6-6
6-7	Overtorque Detection Function ..... 6-7
6-8	DC Injection Braking Function ..... 6-8
6-9	Stall Prevention Function ..... 6-9
6-10	Other Functions ..... 6-11

<b>Chapter 7</b>	<b>Communications</b>	
7-1	RS485 Communication Overview .....	7-1
7-2	Inverter Settings .....	7-2
7-3	Wiring of RS485 .....	7-3
7-4	Communication Basic Format .....	7-5
7-5	Communication setting method .....	7-8
7-6	Register No. assignment and content .....	7-9
7-7	Communication Error Code .....	7-11
7-8	Communication with PC .....	7-12
7-9	Ladder Program Examples .....	7-28
7-10	Communications Time .....	7-31
<b>Chapter 8</b>	<b>Application</b>	
8-1	Protective and Diagnostic Functions .....	8-1
8-2	Troubleshooting .....	8-7
8-3	Maintenance and Inspection .....	8-12
<b>Chapter 9</b>	<b>Specifications</b>	
9-1	Inverter Specifications .....	9-1
<b>Chapter 10</b>	<b>List of Parameters</b>	
10-1	List of Parameters .....	10-1



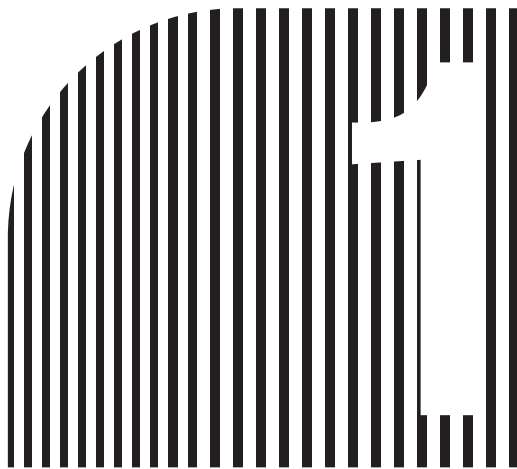

# Chapter 1

## ● Overview ●

1-1 Functions

1-2 Nomenclature

# Chapter 1 Overview

## 1-1 Function

SYSDRIVE 3G3JZ series is a series of simple and aptitude Inverters centre on V / f control with necessary function.

Basic on 3G3JV, 3G3JZ added the necessary function of general motor applcate, and keep simple using.

Equipped RS485 as standard. provide a further control needed to build a connection with PLC.

### ■ SYSDRIVE 3G3JZ Models

3G3JZ series have 3 types by input power supply.

Rated voltage	Enclosure rating	Maximum applied motor capacity	Model	Rated output current
Single-phase 200VAC	In-panel models (IP20)	0.2kW	3G3JZ-AB002	1.6A
		0.4kW	3G3JZ-AB004	2.5A
		0.75kW	3G3JZ-AB007	4.2A
		1.5kW	3G3JZ-AB015	7.5A
		2.2kW	3G3JZ-AB022	11.0A
3-phase 200VAC	In-panel models (IP20)	0.2kW	3G3JZ-A2002	1.6A
		0.4kW	3G3JZ-A2004	2.5A
		0.75kW	3G3JZ-A2007	4.2A
		1.5kW	3G3JZ-A2015	7.5A
		2.2kW	3G3JZ-A2022	11.0A
		3.7kW	3G3JZ-A2037	17A
3-phase 400VAC	In-panel models (IP20)	0.4kW	3G3JZ-A4004	1.5A
		0.75kW	3G3JZ-A4007	2.5A
		1.5kW	3G3JZ-A4015	4.2A
		2.2kW	3G3JZ-A4022	5.5A
		3.7kW	3G3JZ-A4037	8.2A

### **Simple style, standard RS485 equipped**

Be referred to as simple style, but standard RS485 communication equipped, that makes it easy to connect the Programmable logical controller (PLC) or any other host controller.

Only to add to PLC with RS485, control functions can be added on the original inverter device.

In addition, position control can be realized by RS485 communication easily if Omron CP1L series PLC is used. That can help customer system improve the level by RS485 communication function.

### **150% torque can be realized at 3Hz by the function of torque boost**

As the same of 3G3JV, the stronger torque can be output by torque boost function, in favor of improving the device performance.

### **Energy saving function equipped**

Be equipped with energy saving function. It is suitable for the applications that is not complicated control, needn't high-function inverter, but desire to promote the energy saving effects.

Simple fan control and water pumping control can be operated only by the inverter unit, please have a try and feel the effect of energy saving by energy saving control.

### **Unify of the height and the direction of inverter. Side by side setting, utilize controller cabinet efficiently**

Unifying the height of inverter at 174mm, wiring design around can be made efficiently.

And keep the environment temperature at 0-40 ℃, Side by side also can be set(non-gap setting of zero adjoining distance).

The distance between two inverters can be achieved to zero, so it can realize the controller cabinet miniaturization and efficiency greatly.

### **Simple style, realizing the motor run silently**

Simple style, carrier frequency can be set to 15Hz.

Motor can run silently only to set the carrier frequency to 15Hz even in the quiet sites like the tidy room or office.

However, the rate current will be reduced when the carrier frequency is set over 8Hz. Please select model according to the motor rate current.

### **Build-in input function equipped, realizing the control without wiring**

Inverter's input and output control function can be operated only by setting the internal parameters.

Set the FWD running command to the internal input, make this input On through parameter. If the power supply is ON, FWD running will be started without external wiring.

No-wiring can be realized by the internal input function in the simple control with one inverter cell.

### **External braking output function equipped**

It's difficult to set the brake-time properly for some motor in vertical axis. Sensor, inverter's internal signal (running output) or PLC is used to make the delay time.

Our inverter has provided this function in order to set the actuation time for the external braking device directly.

Confirm the device actuation, set the inverter's output frequency when braking action occurred. Setting and debugging can be easily completed by that way.

### **Using conveniently considered, convenient function equipped**

In addition, in view of using conveniently, variety convenient functions had been equipped. Please select them according to the application.

6 Multi-function inputs: based on the former 3G3JV 5 inputs, it has 6 inputs by adding 1 input. That can be widely used in the applications.

Speed adjust knob: speed can be easily adjusted by using the front speed adjust knob.

Simple fan exchange: it is easy to disassemble or install by lightly action without dismantling the inverter.

The former functions like as over torque detect, UP/DOWN operation, etc will be still reserved.

1-2 Nomenclature

■ Console Nomenclature

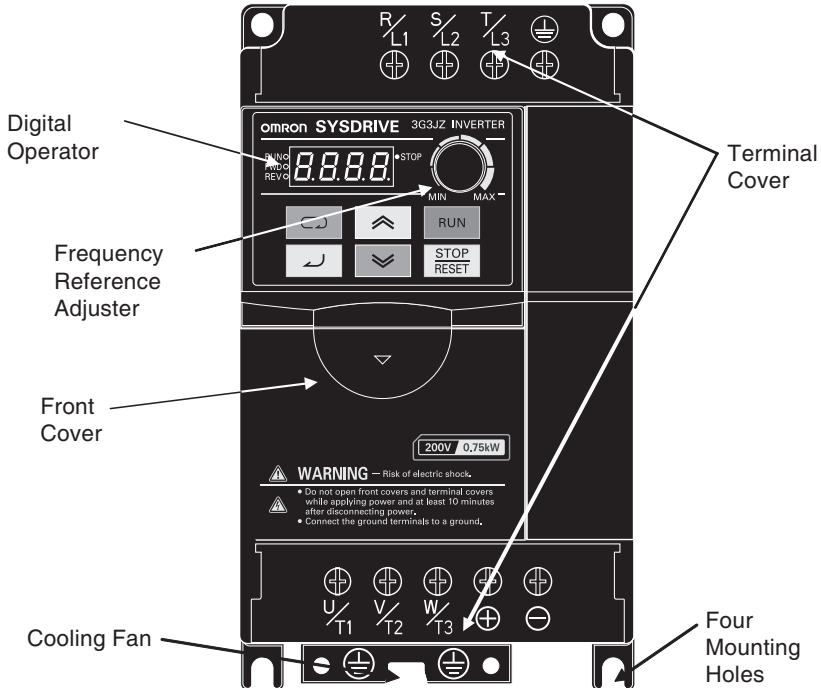

- Minimal models are without terminal covers  
3G3JZ-AB002/AB004/AB007  
3G3JZ-A2002/A2004/A2007/A2015  
3G3JZ-A4004/A4007/A4015
- Self-cooling models are without cooling fans  
3G3JZ-AB002/AB004/AB007  
3G3JZ-A2002/A2004/A2007  
3G3JZ-A4004/A4007

## ■ Nomenclature of Digital Operator



	Name	Function
	Data display	Displays relevant data items, such as frequency command, output frequency, and parameter set values.
	Frequency adjuster	Sets the frequency adjuster within a range between 0 Hz and the maximum frequency.
<b>RUN</b> •	RUN indicator	Lights in operation. Flashes when run command is turned OFF and in deceleration.
<b>FWD</b> •	FWD indicator	Lights when executing a FWD command. Flashes when switching from FWD to REV.
<b>REV</b> •	REV indicator	Lights when executing a REV command. Flashes when switching from REV to FWD.
<b>STOP</b> •	STOP indicator	Lights when stopped. Flashes when running at a frequency which is lower than minimum output frequency.
•	(Carry Display)	Lights when displaying first 4 of 5 digits of the parameter.
	Mode Key	Switches the inverter's monitor display in sequence. Parameter setting being made is canceled if this key is pressed before entering the setting.
	Enter Key	Enters parameter edit mode when pressed in monitor display status. Used when determining parameter No. and displaying parameter set value. In addition, press this button to confirm the parameter change.
	Decrement Key	Decreases the frequency command, parameter numbers, and parameter set values.
	Increment Key	Increases the frequency command, parameter numbers, and parameter set values.
	RUN Key	Starts the Inverter running when the 3G3JZ is in operation with the Digital Operator.
	STOP/RESET Key	Stops the Inverter unless parameter n2.01 is set to disable the STOP Key. Functions as a Reset Key when an Inverter error occurs.



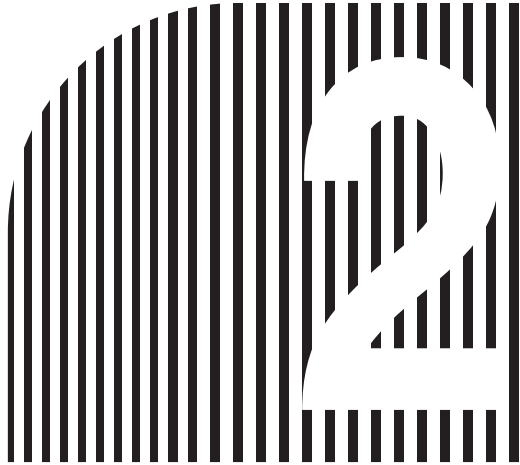

## Chapter 2

### ● Design ●

2-1 Installation

2-2 Wiring

# Section 2 Design

## 2-1 Installation

### 2-1-1 Dimensions

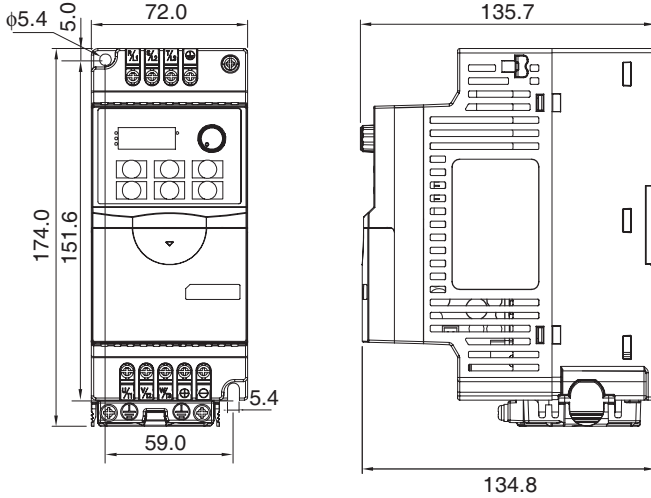

- 3G3JZ-AB002 ~ AB007(0.2 ~ 0.75kW) Single-phase 200-V AC Input
- 3G3JZ-A2002 ~ A2015(0.2 ~ 1.5kW) 3-phase 200-V AC Input
- 3G3JZ-A4004 ~ A4015(0.4 ~ 1.5kW) 3-phase 400-V AC Input

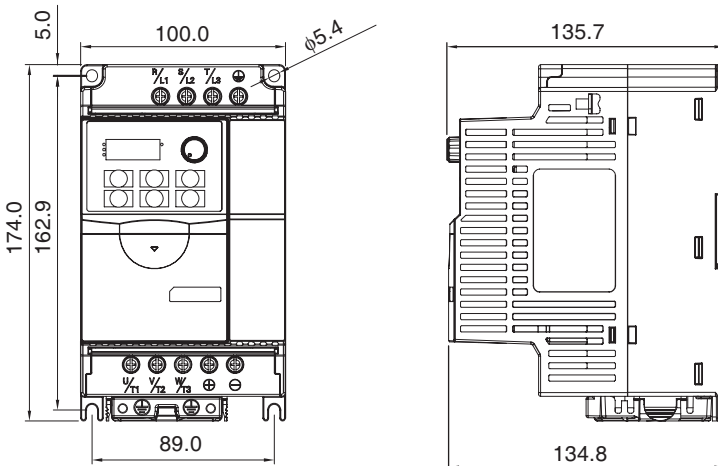

- 3G3JZ-AB015 ~ AB022(1.5 ~ 2.2kW) Single-phase 200-V AC Input
- 3G3JZ-A2022 ~ A2037(2.2 ~ 3.7kW) 3-phase 200-V AC Input
- 3G3JZ-A4022 ~ A4037(2.2 ~ 3.7kW) 3-phase 400-V AC Input



## 2-1-2 Installation Conditions

 <b>Caution</b>	
<p>Precautions on the dangers of high-voltage equipment. Place a cover over the Inverter during installation to shield it from metal powder produced by drilling.</p>	

<b>Safety Precautions</b>
---------------------------

(1) Do not store, install, or operate the product in the following places. Doing so may result in electrical shock, fire or damage to the product.

1. Locations subject to direct sunlight.
2. Locations subject to temperatures outside the range specified in the specifications.  
Ambient temperature:  $-10\text{ }^{\circ}\text{C} \sim +50\text{ }^{\circ}\text{C}$   
(Close mounting:  $-10\text{ }^{\circ}\text{C} \sim +40\text{ }^{\circ}\text{C}$ ) ;
3. Locations subject to humidity outside the range specified in the specifications.  
Ambient humidity: 90%RH or less ;
4. Locations subject to condensation as the result of severe changes in temperature.
5. Locations subject to corrosive or flammable gases.
6. Locations subject to exposure to combustibles.
7. Locations subject to dust (especially iron dust) or salts.
8. Locations subject to exposure to water, oil, or chemicals.
9. Locations subject to shock or vibration.

(2) Transportation and Setting Precautions

1. Prevent shock and fall. Doing so may result in damage to the product or malfunction.
2. Take appropriate and sufficient countermeasures when installing systems in the following locations.

Not doing so may result in equipment damage.:

- Locations subject to static electricity or other forms of noise.
- Locations subject to strong electromagnetic fields and magnetic fields.
- Locations close to power supplies.

<b>Precautions</b>
--------------------

(1) Installation

Install the Inverter vertically Closed Wall-mounting.  
When installing the Inverter, always provide the installation space to allow normal heat dissipation.

## Section 2 Design

### ■ Installation Conditions

- Install the Inverter under the following conditions.

Ambient temperature for operation (Panel-mounting):-10 ~ +50 °C ; (Close mounting):-10 ~ +40 °C

Humidity: 90%RH or less (no condensation)

- Install the Inverter in a clean location free from oil mist and dust. Alternatively, install it in a totally enclosed panel that is completely protected from floating dust.
- When installing or operating the Inverter, always take special care so that metal powder, oil, water, or other foreign matter does not get into the Inverter.
- Do not install the Inverter on inflammable material such as wood.

### ■ Installation Direction

- Install the Inverter on a vertical surface so that the characters on the nameplate are oriented upward.

### ■ Dimensions

- When installing the Inverter, always provide the following clearances to allow normal heat dissipation from the Inverter.

● 3G3JZ-AB002 ~ AB007(0.2 ~ 0.75kW) Single-phase 200-V AC Input

3G3JZ-A2002 ~ A2007(0.2 ~ 0.75kW) 3-phase 200-V AC Input

3G3JZ-A4004 ~ A4007(0.4 ~ 0.75kW) 3-phase 400-V AC Input

- Normal mounting:-10 ~ +50 °C

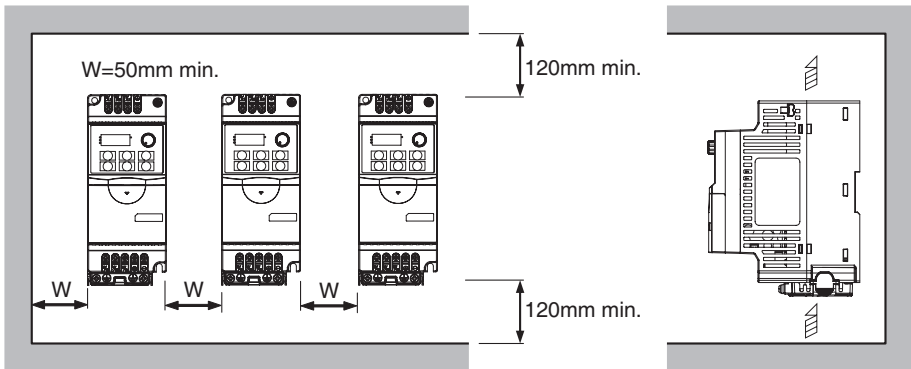

- Close mounting:-10 ~ +40 °C

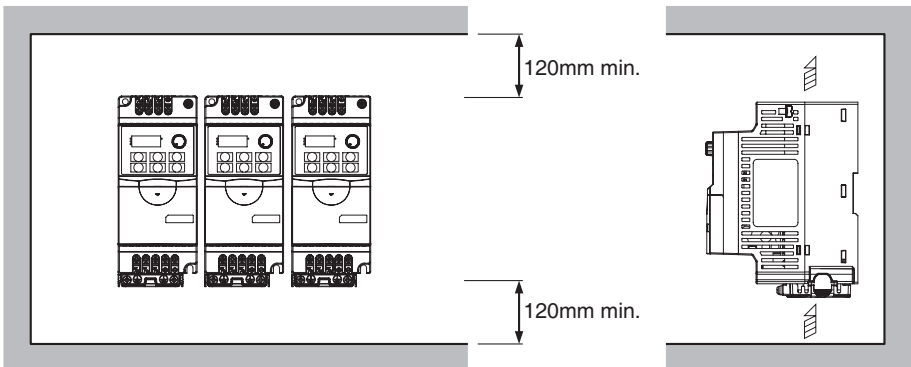

- 3G3JZ-AB015 ~ AB022(1.5 ~ 2.2kW) Single-phase 200-V AC Input  
3G3JZ-A2015 ~ A2037(1.5 ~ 3.7kW) 3-phase 200-V AC Input  
3G3JZ-A4015 ~ A4037(1.5 ~ 3.7kW) 3-phase 400-V AC Input

- Normal mounting:-10 ~ +50 °C

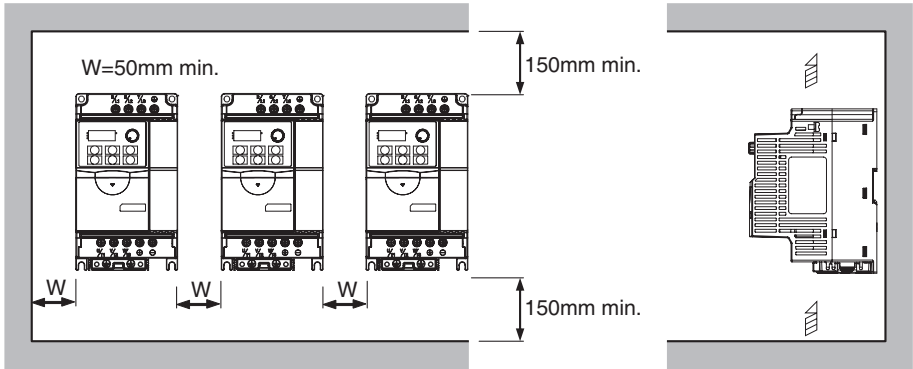

- Close mounting:-10 ~ +40 °C

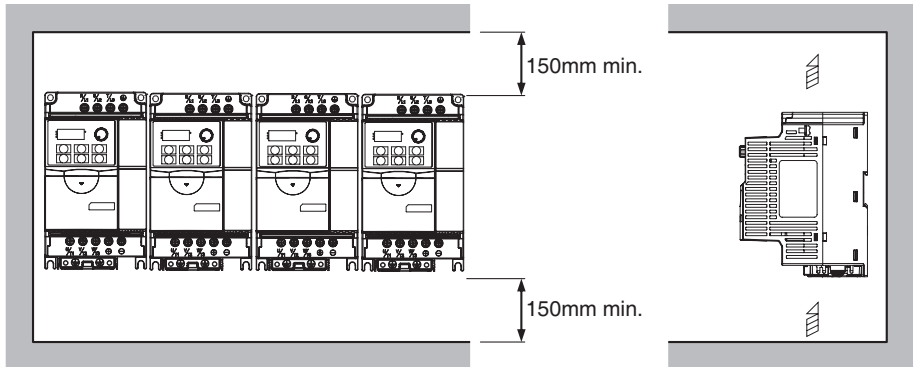

### ■ Ambient Temperature Control







- To enhance operation reliability, the Inverter should be installed in an environment free from extreme temperature changes.
- If the Inverter is installed in an enclosed environment such as a box, use a cooling fan or air conditioner to maintain the internal air temperature below 50 °C (Close mounting: below 40 °C ).The life of the built-in electrolytic capacitors of the Inverter is prolonged by maintaining the internal air temperature as low as possible.
- The surface temperature of the Inverter may rise approximately 30 °C higher than the ambient temperature. Be sure to keep away equipment and wires from the Inverter as far as possible if the equipment and wires are easily influenced by heat.

### ■ Protecting Inverter from Foreign Matter during Installation

- Place a cover over the Inverter during installation to shield it from metal power produced by drilling.

Upon completion of installation, always remove the cover from the Inverter. Otherwise, ventilation will be affected, causing the Inverter to overheat.

2-2 Wiring

 <b>Precautions</b>	
Not connecting to a proper ground may result in electrical shock.	
Provide an external emergency stopping device that allows an instantaneous stop of operation and power interruption. Not doing so may result in injury.	
Disconnect all power before opening front cover of unit. Wait 10 minutes until DC Bus capacitors discharge. Use proper grounding techniques. Not doing so may cause injury or electric shock.	
Always connect the Inverter and power supply via a molded case circuit breaker (MCCB) suitable to the Inverter for protecting the Inverter from damage that may result from short-circuiting.	
Precautions on the dangers of high-voltage equipment. Place a cover over the Inverter during installation to shield it from metal powder produced by drilling.	

**Safety Precautions**

- (1) Wiring
1. Do not connect an AC power to the U/T1、 V/T2、 W/T3 terminals. Doing so may result in damage to the product or malfunction.
  2. Always connect the output terminals (U/T1、 V/T2、 W/T3) to a ground of 100 Ω or less for the 200-VAC class, or 10 Ω or less for the 400-VAC class.
  3. Do not connect AC power to the output and input control terminals, except the relay output control terminal. Not doing so may result in damage to the product.
  4. For the main circuit and ground, always use 600-V polyvinyl chloride (PVC) cables. Be sure to firmly tighten the screws on the terminal block. Not doing so may result in fire, injury, or damage to the product.
  5. To prevent vertical load drops, be sure to confirm the operation after setting and wiring when using external braker output. Not doing so may result in injury.

**Precautions**

- (1) Main circuit power supply  
Inverter power supply:
- Single-phase 200-V 200 ~ 240VAC 50/60Hz
  - 3-phase 200-V 200 ~ 240VAC 50/60Hz
  - 3-phase 400-V 380 ~ 480VAC 50/60Hz
- (2) Installing a Thermal Overload Relay(electronic thermal)
- This Inverter has an electronic thermal protection function to protect the motor from overheating. Set the Motor Rated Current (n7.00) the same as the used motor's rated current. If, however, more than one motor is operated with one Inverter or a multi-polar motor is used, always install a therm alrelay (THR) between the Inverter and the motor and set motor protection(n6.06) to 0 (no motor protection). Set the thermal relay (THR) at 1.0 (for 50Hz or less) and 1.1 (for 60Hz or less) times the rated current value on the motor nameplate.

## 2-2-1 Removing and Mounting the Covers

To wire the Inverter, it is not necessary to remove the front cover, terminal cover (unless the Inverter is a low-capacity 200-V model).

To set Inverter remotely by the digital operator, it is necessary to remove the Digital Operator.

Follow the commands below to remove the covers from the Inverter. To mount the covers, take the opposite steps.

### ■ Removing the Front Cover

- Press the front cover in the arrow directions.
- Remove the front cover as shown in the following illustration.

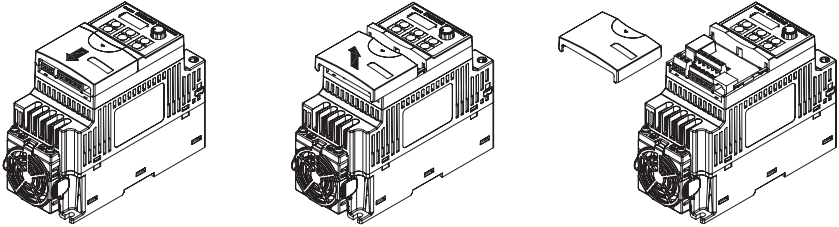

### ■ Removing the Terminal Cover

- Press the dish in central of the cover, lift it in the direction of arrow as shown in the following illustration.

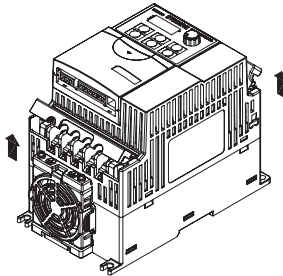

## Section 2 Design

### 2-2-2 Terminal Block

To wire the terminal block of the Inverter, remove the front cover, terminal cover (unless the Inverter is a low-capacity model), and bottom cover from the Inverter.

There is a label under the front cover indicating the arrangement of main circuit terminals or control circuit terminals. Be sure to remove the label after wiring the terminals.

#### ■ Arrangement of Control Circuit Terminals and RS485 Communication Connector

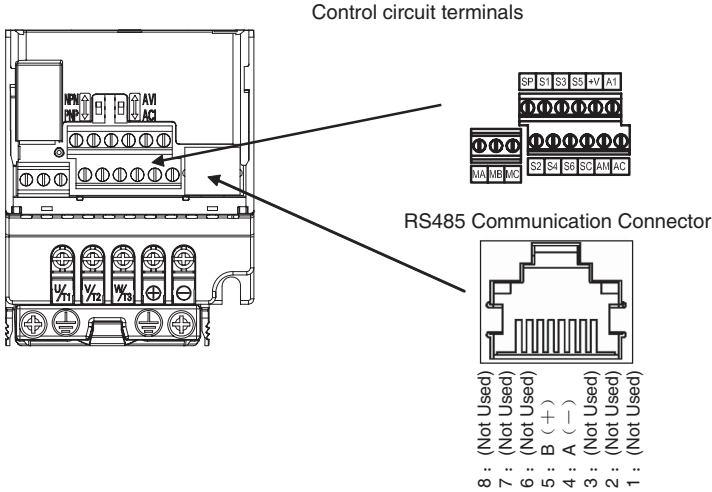

#### ■ Arrangement of Main Circuit Terminals

- Main Circuit Terminal -Input(upside)
- Main Circuit Terminal -Output(downdside)

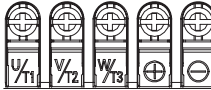
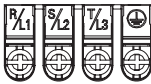

## ■ Main Circuit Terminals

Symbol	Name	Description
R/L1	Power supply input terminals ※ 1	<ul style="list-style-type: none"> <li>• 3G3JZ-AB □: Single-phase 200 ~ 240VAC</li> <li>• 3G3JZ-A2 □: 3-phase 200 ~ 240VAC ※ 1</li> <li>• 3G3JZ-A4 □: 3-phase 380 ~ 480VAC</li> </ul>
S/L2		
T/L3		
U/T1	Motor output terminals ※ 2	3-phase power supply output for driving motors. ※ 2 <ul style="list-style-type: none"> <li>• 3G3JZ-AB □: 3-phase 200 ~ 240VAC</li> <li>• 3G3JZ-A2 □: Single-phase 200 ~ 240VAC</li> <li>• 3G3JZ-A4 □: 3-phase 380 ~ 480VAC</li> </ul>
V/T2		
W/T3		
+	DC Power supply input terminals ※ 3	DC Power supply input terminals
-		
	Ground terminal	Be sure to ground the terminal under the following conditions. <ul style="list-style-type: none"> <li>• 3G3JZ-AB □、3G3JZ-A2 □: Ground at a resistance of 100 Ω or less.</li> <li>• 3G3JZ-A4 □: Ground at a resistance of 100 Ω or less.</li> </ul> ※ Be sure to connect the ground terminal directly to the motor frame ground.

※ 1. Connect single-phase input to both the R/L1 terminal and the S/L2 terminal.

※ 2. The maximum voltage at the output side corresponds to the power supply voltage for Inverter input.

## ■ Control Circuit Terminals

Symbol	Name	Specification	
Input	S1	Multi-function input 1(Forward/Stop)	
	S2	Multi-function input 2(Reverse/Stop)	
	S3	Multi-function input 3(External fault)	
	S4	Multi-function input 4(Fault reset)	
	S5	Multi-function input 5 (Multi-step speed reference1)	
	S6	Multi-function input 6 (Multi-step speed reference2)	
	SC	Sequence input common	
	SP	Sequence power supply +24V	+24VDC 20mA
	AC	Analog common	Analog input, analog output 0V
	A1	frequency command input	0 ~ +10VDC(10 bit)/47kΩ
	+V	frequency command power supply	+10VDC 20mA
Output	MA	Multi-function output 1a contact output (Normally open: Fault)	
	MB	Multi-function output 1b contact output (Normally closed: Fault)	
	MC	Multi-function output 1 common	
	AM	Multi-function analog output	
	(AC)	Analog common ※ 3	
		Relay output • Impedance loads +24VDC 3A max./250VAC 3A max. • Inductive loads +24VDC 0.5A max./250VAC 0.5A max.	
		0 ~ +10VDC(8 bit) 2mA ※ 4	

- ※ 1.Parameter settings can be used to select various functions for multi-function inputs 1 ~ 6,multi-function output 1. The functions in parentheses are the default settings.
- ※ 2.Parameter settings can be used to set and change the input/output rated voltage(current) for the output of frequencereference output, multi-function analog input, multi-function analog output. The parameters above are the default settings.
- ※ 3.Both analog input and analog output are use the same analog common.
- ※ 4.The analog out of 3G3JZ is a PWM wave which the carrier frequency is 1KHz and it could connect to the analog input directly. If need to view the wave by oscillograph,you must use filter the electrct circuit like this  
 $R=100K\Omega, C=0.1\mu F$ .

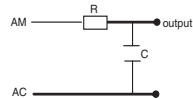

## ■ RS485 Communication Connector

Symbol	Name	Specification	
Connect Pin	1p	— (Not used)	—
	2p	— (Not used)	—
	3p	— (Not used)	—
	4p	A(-) RS485communication send/receive data —	RS485communication send/receive signal.
	5p	B(+) RS485 communication send/receive data +	※ Conform to the MODBUS Communications Protocol.
	6p	— (Not used)	—
	7p	— (Not used)	—
	8p	— (Not used)	—

※ Please use the connector and cables used for Ethernet.

### ■ Selecting Input Method

• Switches control circuit terminal Sequence Input Method SW and Multi-function Analog Input Method SW, both of which are located above the control circuit terminals, are used for input method selection.

※ The setting SW on back of the Digital Operator are used for manufacturer settings. Do not change the settings.

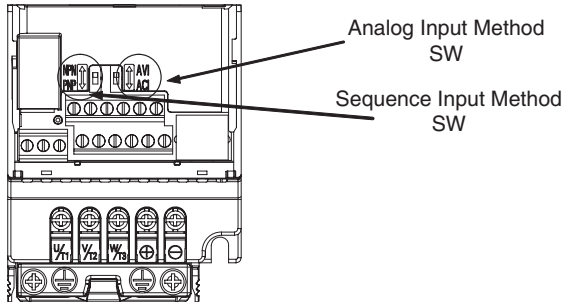

### ● Selecting Sequence Input Method (NPN/PNP)

• By using Sequence Input Method SW, NPN or PNP input can be selected as shown below.

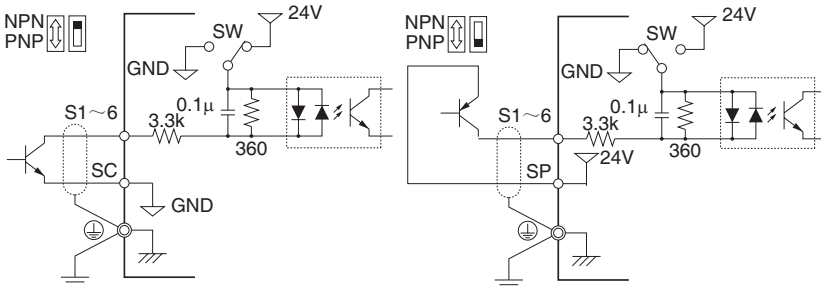

### ● Selecting frequency command input Method

• By using Multi-function Analog Input Method SW, Multi-function analog input voltage or current input can be selected. Parameter settings are required together with the selection of the Multi-function analog input method.

• Default setting current input (4 ~ 20mA)

Multi-function Analog Input Method	SW Setting	frequency command Input A1 terminal setting
Voltage input	AVI	Set value"1"
Current input	ACI	Set value"0"

※ When using analog input in voltage input, if set Multi-function analog input SW to "ACI", may cause the damage in input circuit. Please select properly according to the input method.

## Section 2 Design

### 2-2-3 Standard Connections

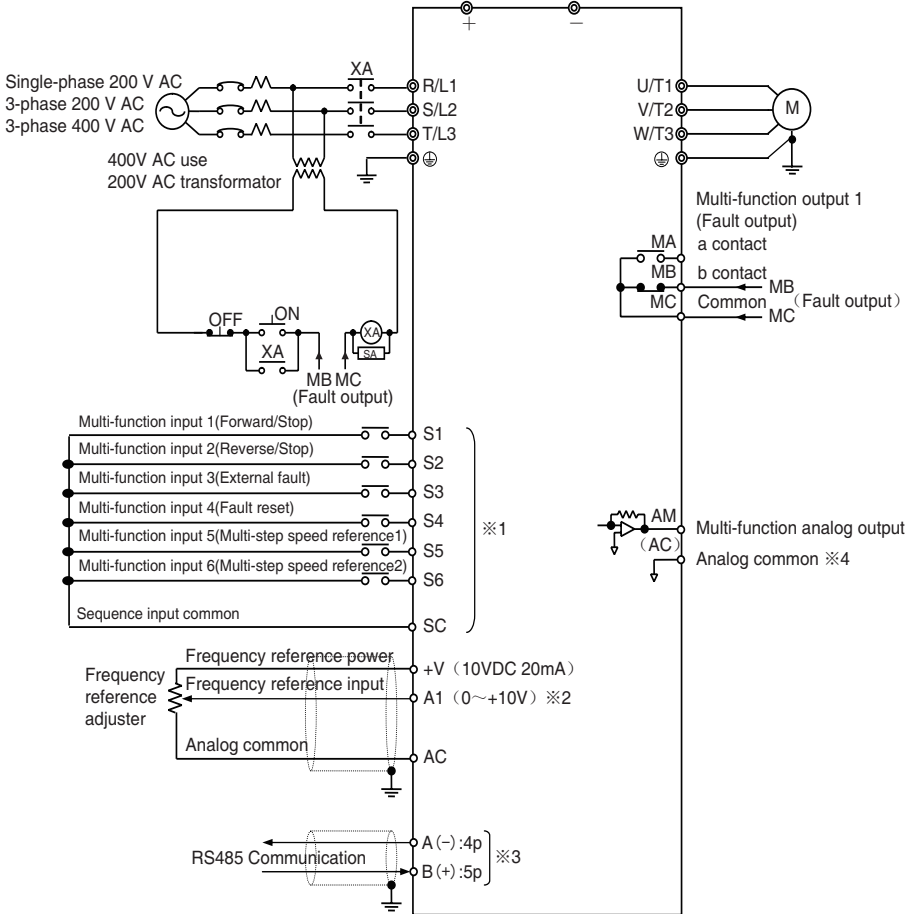

- ※ 1. Control circuit terminal shows the NPN wiring as the default setting. By using Sequence Input Method SW, PNP input can be selected.
- ※ 2. Multi-function analog input shows the current input A1 as the default setting. By using Multi-function analog input Method SW.
- ※ 3. Use standard connector wires (for Ethernet) to wiring RS485.
- ※ 4. Analog input common is the same as analog output common terminal. Analog output is the PWM wave which the carrier frequency is 1KHz, and it could connect to analog input directly.

## ● Example of 3-wire Sequence Connections

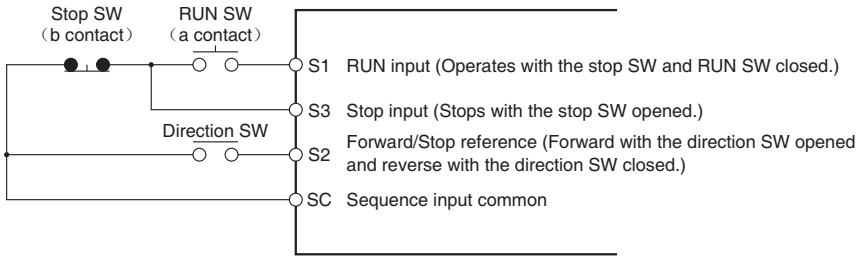

※Set parameter(n4.04) for 3-wire sequence input.





## Section 2 Design

### 2-2-4 Wiring around the Main Circuit







#### ■ Wire Size, Terminal Screw, Screw Tightening Torque, and Molded-case Circuit Breaker Capacities

- For the main circuit and ground, always use 600-V polyvinyl chloride (PVC) cables.  
If any cable is long and may cause voltage drops, increase the wire size according to the cable length.

#### ● Singel-phase 200-V AC Model

Model 3G3JZ-	Terminal Symbol	Terminal screw	Screw tightening torque [N · m]	Wire size [mm <sup>2</sup> ]	Recom- mended wire size [mm <sup>2</sup> ]	Molded- case circuit breaker capacity [A]
AB002	R/L1,S/L2,T/L3,+,-,U/T1,U/T2,U/T3	M3.5	0.8 ~ 1.0	0.75 ~ 2	2	5A
						
AB004	R/L1,S/L2,T/L3,+,-,U/T1,U/T2,U/T3	M3.5	0.8 ~ 1.0	0.75 ~ 2	2	10A
						
AB007	R/L1,S/L2,T/L3,+,-,U/T1,U/T2,U/T3	M3.5	0.8 ~ 1.0	2 ~ 5.5	3.5	20A
						
AB015	R/L1,S/L2,T/L3,+,-,U/T1,U/T2,U/T3	M4	1.2 ~ 1.5	2 ~ 5.5	5.5	20A
					3.5	
AB022	R/L1,S/L2,T/L3,+,-,U/T1,U/T2,U/T3	M4	1.2 ~ 1.5	2 ~ 5.5	5.5	40A
						

#### ● 3-phase 200-V AC Model

Model 3G3JZ-	Terminal Symbol	Terminal screw	Screw tightening torque [N · m]	Wire size [mm <sup>2</sup> ]	Recom- mended wire size [mm <sup>2</sup> ]	Molded- case circuit breaker capacity [A]
A2002	R/L1,S/L2,T/L3,+,-,U/T1,U/T2,U/T3	M3.5	0.8 ~ 1.0	0.75 ~ 2	2	5A
						
A2004	R/L1,S/L2,T/L3,+,-,U/T1,U/T2,U/T3	M3.5	0.8 ~ 1.0	0.75 ~ 2	2	5A
						
A2007	R/L1,S/L2,T/L3,+,-,U/T1,U/T2,U/T3	M3.5	0.8 ~ 1.0	0.75 ~ 2	2	10A
						
A2015	R/L1,S/L2,T/L3,+,-,U/T1,U/T2,U/T3	M3.5	0.8 ~ 1.0	2 ~ 5.5	2	20A
					3.5	
A2022	R/L1,S/L2,T/L3,+,-,U/T1,U/T2,U/T3	M4	1.2 ~ 1.5	2 ~ 5.5	3.5	20A
						
A2037	R/L1,S/L2,T/L3,+,-,U/T1,U/T2,U/T3	M4	1.2 ~ 1.5	2 ~ 5.5	5.5	30A
						

## ● 3-phase 400-V AC Model

Model 3G3JZ-	Terminal Symbol	Terminal screw	Screw tightening torque [N · m]	Wire size [mm <sup>2</sup> ]	Recommended wire size [mm <sup>2</sup> ]	Molded-case circuit breaker capacity [A]
A4004	R/L1,S/L2,T/L3,+,-,U/T1,U/T2,U/T3 ⊕	M3.5	0.8 ~ 1.0	2 ~ 5.5	2	5A
A4007	R/L1,S/L2,T/L3,+,-,U/T1,U/T2,U/T3 ⊕	M3.5	0.8 ~ 1.0	2 ~ 5.5	2	5A
A4015	R/L1,S/L2,T/L3,+,-,U/T1,U/T2,U/T3 ⊕	M3.5	0.8 ~ 1.0	2 ~ 5.5	2	10A
A4022	R/L1,S/L2,T/L3,+,-,U/T1,U/T2,U/T3 ⊕	M4	1.2 ~ 1.5	2 ~ 5.5	2	10A
A4037	R/L1,S/L2,T/L3,+,-,U/T1,U/T2,U/T3 ⊕	M4	1.2 ~ 1.5	2 ~ 5.5	3.5	20A

## ■ Wiring on the Input Side of the Main Circuit

## ● Installing a Molded-case Circuit Breaker

Always connect the power input terminals (R/L1, S/L2, and T/L3) and power supply via a molded case circuit breaker (MCCB) suitable to the Inverter.

- Install one MCCB for every Inverter used.
- Choose an appropriate MCCB capacity according to the Circuit breaker capacity column in the table on the previous page.
- For the MCCB's time characteristics, be sure to consider the Inverter's overload protection (one minute at 150% of the rated output current)
- If the MCCB is to be used in common among multiple Inverters, or other devices, set up a sequence such that the power supply will be turned off by a fault output, as shown in the following diagram.

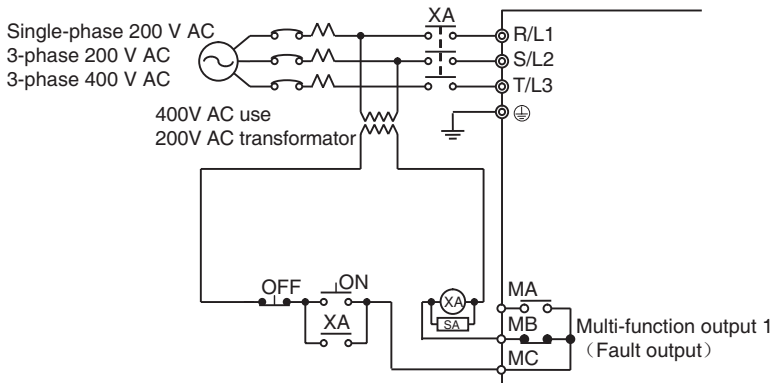

## Section 2 Design

### ● Installing a Ground Fault Interrupter

Inverter outputs use high-speed switching, so high-frequency leakage current is generated. In general, a leakage current of approximately 100 mA will occur for each Inverter (when the power cable is 1 m) and approximately 5 mA for each additional meter of power cable.

Therefore, at the power supply input area, use a special-purpose breaker for Inverters, which detects only the leakage current in the frequency range that is hazardous to humans and excludes high-frequency leakage current.

- For the special-purpose breaker for Inverters, choose a ground fault interrupter with a sensitivity amperage of at least 10 mA per Inverter.
- When using a general leakage breaker, choose a ground fault interrupter with a sensitivity amperage of 200 mA or more per Inverter and with an operating time of 0.1 s or more.

### ● Installing a Magnetic Contactor

If the power supply of the main circuit is to be shut off because of the sequence, a magnetic contactor(MC) can be used instead of a molded-case circuit breaker(MCCB).

When a magnetic contactor is installed on the primary side of the main circuit to stop a load forcibly, however, the regenerative braking does not work and the load coasts to a stop.

- A load can be started and stopped by opening and closing the magnetic contactor on the primary side. Frequently opening and closing the magnetic contactor, however, may cause the Inverter to break down. In order not to shorten the service life of the Inverter's internal relays and electrolytic capacitors, it is recommended that the magnetic contactor is used in this way no more than once every 30 minutes.
- When the Inverter is operated with the Digital Operator, automatic operation cannot be performed after recovery from a power interruption.

### ● Connecting Input Power Supply to the Terminal Block

Input power supply can be connected to any terminal on the terminal block because the phase sequence of input power supply is irrelevant to the phase sequence (R/L1, S/L2, and R/L3).

### ● Installing an AC Reactor

If the Inverter is connected to a large-capacity power transformer (660 kW or more) or the phase advance capacitor is switched, an excessive peak current may flow through the input power circuit, causing the converter unit to break down.

To prevent this, install an optional AC reactor (optional) on the input side of the Inverter. This also improves the power factor on the power supply side.

### ● Installing a Surge Absorber

Always use a surge absorber or diode for the inductive loads near the Inverter. These inductive loads include magnetic contactors, electromagnetic relays, solenoid valves, solenoid, and magnetic brakes.

### ● Installing a Noise Filter on the Power Supply Side

The Inverter's outputs uses high-speed switching, so noise may be transmitted from the Inverter to the power line and adversely effect other devices in the vicinity. It is recommended that a Noise Filter be installed at the Power Supply to minimize noise transmission. Noise will also be reduced from the power line to the Inverter.

- Wiring Example

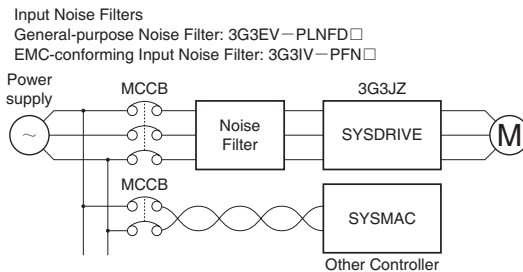

※ Use a Noise Filter designed for the Inverter.

A general-purpose Noise Filter will be less effective and may not reduce noise.

## ■ Wiring on the Output Side of the Main Circuit

### ● Connecting the Terminal Block to the Load

Connect output terminals U/T1, V/T2, and W/T3 to motor lead wires U, V, and W. Check that the motor rotates forward with the forward command. Switch over any two of the output terminals (U/T1, V/T2, W/T3) to each other and reconnect if the motor rotates in reverse with the forward command.

### ● Never Connect a Power Supply to Output Terminals

Never connect a power supply to output terminals U/T1, V/T2, or W/T3. If voltage is applied to the output terminals, the internal circuit of the Inverter will be damaged.

### ● Never Short or Ground Output Terminals

If the output terminals are touched with bare hands or the output wires come into contact with the Inverter casing, an electric shock or grounding will occur. This is extremely hazardous. Also, be careful not to short the output wires.

### ● Do not Use a Phase Advancing Capacitor or Noise Filter

Never connect a phase advance capacitor or LC/RC Noise Filter to the output circuit. Doing so will result in damage to the Inverter or cause other parts to burn.

### ● Do not Use an Electromagnetic Switch or Magnetic Contactor

Do not connect an electromagnetic switch or magnetic contactor to the output circuit. If a load is connected to the Inverter during running, an inrush current will actuate the overcurrent protective circuit in the Inverter.

### ● Installing a Thermal Relay

The Inverter has an electronic thermal protection function to protect the motor from overheating. If, however, more than one motor is operated with one inverter or a multi-polar motor is used, always install a thermal relay (THR) between the Inverter and the motor and set n6.06(moto protection function) to 2 (no thermal protection). In this case, program the sequence so that the magnetic contactor on the input side of the main circuit is turned off by the contact of the thermal relay.

### ● Installing a Noise Filter on the Output Side

Connect a Noise Filter to the output side of the Inverter to reduce radio noise and induction noise.

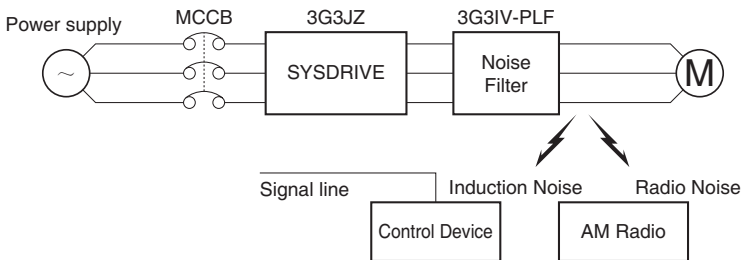

**Induction Noise:** Electromagnetic induction generates noise on the signal line, causing the controller to malfunction.  
**Radio Noise:** Electromagnetic waves from the Inverter and cables cause the broadcasting radio receiver to make noise.

## Section 2 Design

### ● Countermeasures against Induction Interference

As described previously, a Noise Filter can be used to prevent induction noise from being generated on the output side. Alternatively, cables can be routed through a grounded metal pipe to prevent induction noise. Keeping the metal pipe at least 30 cm away from the signal line considerably reduces induction noise.

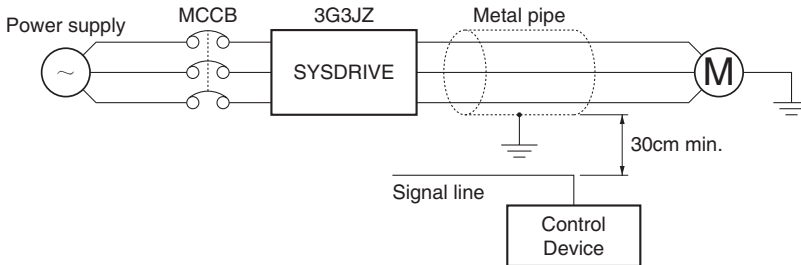

### ● Countermeasures against Radio Interference

Radio noise is generated from the Inverter as well as the input and output lines. To reduce radio noise, install Noise Filters on both input and output sides, and also install the Inverter in a totally enclosed steel box.

The cable between the Inverter and the motor should be as short as possible.

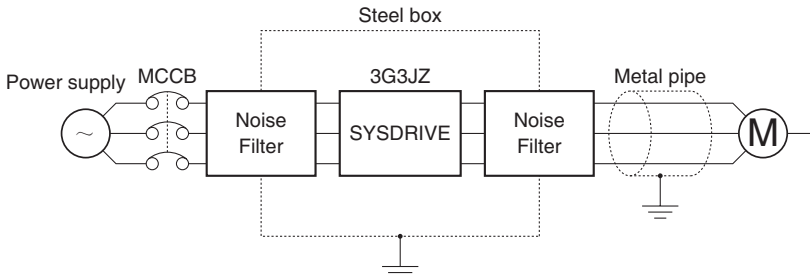

### ● Cable Length between Inverter and Motor

As the cable length between the Inverter and the motor is increased, the floating capacity between the Inverter outputs and the ground is increased proportionally. The increase in floating capacity at the Inverter outputs causes the high-frequency leakage current to increase, and this may adversely affect peripheral devices and the current detector in the Inverter's output section. To prevent this from occurring, use a cable of no more than 100 meters between the Inverter and the motor. If the cable must be longer than 100 meters, take measures to reduce the floating capacity by using AC Reactor on output side,

(choose AC Reactor the same as the one on the input side and set carrier frequency 2K max.)

Also, adjust the carrier frequency according to the cable length between the Inverter and the motor, as shown in the following table.

Cable length	50m max.	100m max.	More than 100m
Carrier frequency	10kHz max.	5kHz max.	2kHz max.

### ● Single-phase motors cannot be used

The Inverter is not suited for the variable speed control of single-phase motors.

The rotation direction of a single-phase motor is determined by the capacitor starting method or phase-splitting starting method to be applied when starting the motor.

In the capacitor starting method, however, the capacitor may be damaged by a sudden electric discharge of the capacitor caused by the output of the Inverter. On the other hand, the starting coil may burn in the phase-splitting starting method because the centrifugal switch does not operate.

**■地線の配线**

- Always use the ground terminal with the following ground resistance:  
200-V Inverter: 100  $\Omega$  or less  
400-V Inverter: separate ground, 10  $\Omega$  or less
- Do not share the ground wire with other devices such as welding machines or power tools.
- Always use a ground wire that complies with technical standards on electrical equipment and minimize the length of the ground wire.  
Leakage current flows through the Inverter. Therefore, if the distance between the ground electrode and the ground terminal is too long, the potential on the ground terminal of the Inverter will become unstable.
- When using more than one Inverter, be careful not to loop the ground wire.

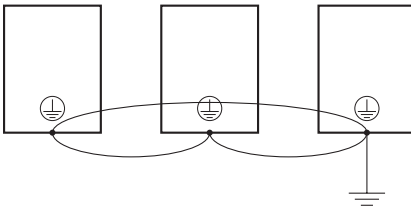
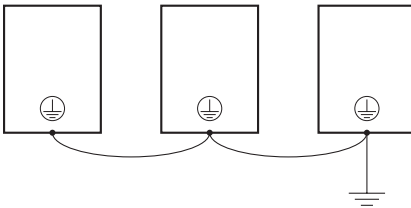
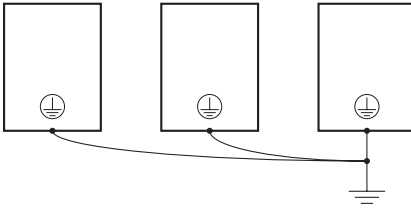

## Section 2 Design

### ■ Countermeasures against Harmonics

With the continuing development of electronics, the generation of harmonics from industrial machines has been causing problems recently.

#### ● Harmonics

##### • Definition

Harmonics consist of electric power produced from AC power and alternating at frequencies that are integral multiples of the frequency of the AC power. The following frequencies are harmonics of a 60- or 50-Hz commercial power supply.

Second harmonic: 120 (100) Hz

Third harmonic: 180 (150) Hz

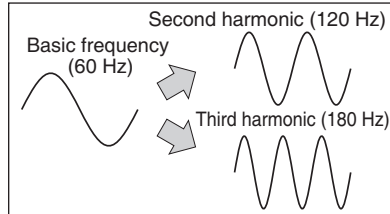

##### • Problems Caused by Harmonics Generation

The waveform of the commercial power supply will be distorted if the commercial power supply contains excessive harmonics. Machines with such a commercial power supply will malfunction or generate excessive heat.

- If basic frequency reaches kHz, then the high harmonics of it will be the high frequency harmonics.

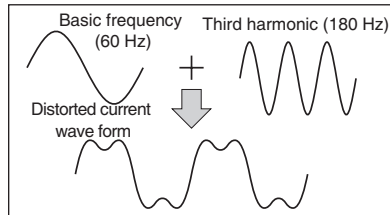

#### ● Causes of Harmonics Generation

- Usually, electric machines have built-in circuitry that converts commercial AC power supply into DC power. Such AC power, however, contains harmonics due to the difference in current flow between DC and AC.

##### • Obtaining DC from AC Using Rectifiers and Capacitors

DC voltage is obtained by converting AC voltage into a pulsating one-side voltage with rectifiers and smoothing the pulsating one-side voltage with capacitors. Such AC current, however, contains harmonics.

##### • Inverter

The Inverter as well as normal electric machines has an input current containing harmonics because the Inverter converts AC into DC. The output current of the Inverter is comparatively high. Therefore, the ratio of harmonics in the output current of the Inverter is higher than that of any other electric machine.

A current flows into the capacitors. The current is different from the voltage in waveform.

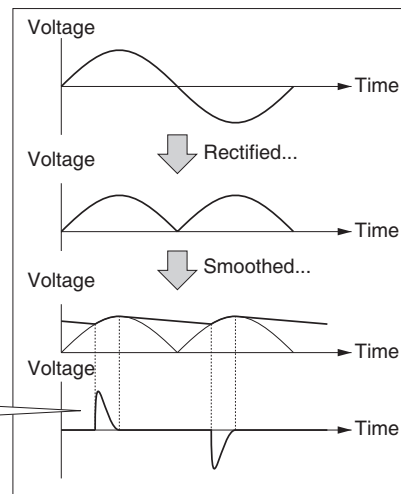

● Countermeasures with Reactors against Harmonics Generation

• AC Reactors

The AC reactor suppress harmonics and currents that change suddenly and greatly.

The input power factor of the Inverter is improved by suppressing the harmonics of the input current of the Inverter.

• Wiring Method

[ With ACReactor ]

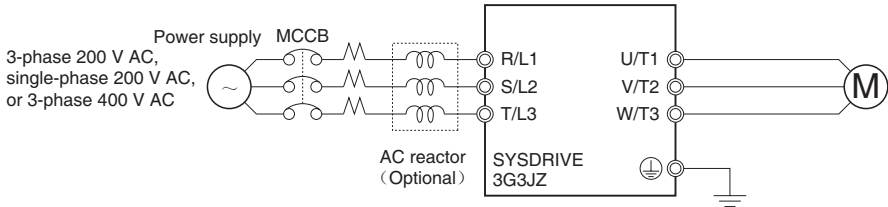

• Reactor Effects

Harmonics are effectively suppressed when the AC reactor is used as shown in the following table.

Harmonics suppression method	Harmonic generation rate (%)							
	5th harmonic	7th harmonic	11th harmonic	13th harmonic	17th harmonic	19th harmonic	23th harmonic	25th harmonic
No reactor	65	41	8.5	7.7	4.3	3.1	2.6	1.8
AC reactor	38	14.5	7.4	3.4	3.2	1.9	1.7	1.3

## Section 2 Design

### 2-2-5 Wiring Control Circuit Terminals

A control signal line must be 50 m maximum and separated from power lines.  
The frequency command must be input into the Inverter through shielded, twisted-pair wires.

#### ■ Wiring of Control I/O Terminals

Wire each control I/O terminal under the following conditions.

##### ● Wires and Tightening Torque

- Multi-function Contact Output I(MA, MB, MC)

Terminal screw size	Tightening torque N · m	Wire	Wire size mm <sup>2</sup> (AWG)	Recommended wire size mm <sup>2</sup> (AWG)	Cable
M3	0.5 ~ 0.6	Single wire	0.5 ~ 1.25(20 ~ 16)	0.75(18)	Cable with polyethylene sheath
		Stranded wire	0.5 ~ 1.25(20 ~ 16)		

- Sequential Input (S1 through S6, SP and SC) and Analog Monitor Output (AM or AC)

Terminal screw size	Tightening torque N · m	Wire	Wire size mm <sup>2</sup> (AWG)	Recommended wire size mm <sup>2</sup> (AWG)	Cable
M2	0.22 ~ 0.25	Single wire	0.5 ~ 1.25(20 ~ 16)	0.75(18)	Cable with polyethylene sheath
		Stranded wire	0.5 ~ 0.75(20 ~ 18)		

- Frequency command Input (A1, +V, AC)

Terminal screw size	Tightening torque N · m	Wire	Wire size mm <sup>2</sup> (AWG)	Recommended wire size mm <sup>2</sup> (AWG)	Cable
M2	0.22 ~ 0.25	Single wire	0.5 ~ 1.25(20 ~ 16)	0.75(18)	Special cable with polyethylene sheath and shield for measurement use
		Stranded wire	0.5 ~ 0.75(20 ~ 18)		

##### ● Solderless Terminal Size

The use of solderless terminals for the control circuit terminals is recommended for the reliability and ease of connection.

※ Make sure that the wire size is 0.5 mm<sup>2</sup> when using the following solderless terminal.

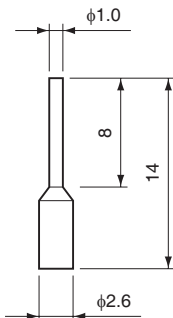

Model: AI 0.5-8 WH

(Size:mm)

**● Wiring Method**

- ① Loosen the terminal screws with a thin-slotted screwdriver.
  - ② Insert the wires from underneath the terminal block.
  - ③ Tighten the terminal screws firmly to a torque of  $0.5 \text{ N} \cdot \text{m}$ .
- ※ 1. Always separate the control signal line from the main circuit cables and other power cables.
  - ※ 2. Do not solder the wires to the control circuit terminals. The wires may not contact well with the control circuit terminals if the wires are soldered.
  - ※ 3. The end of each wire connected to the control circuit terminals must be stripped for approximately 5.5 mm.

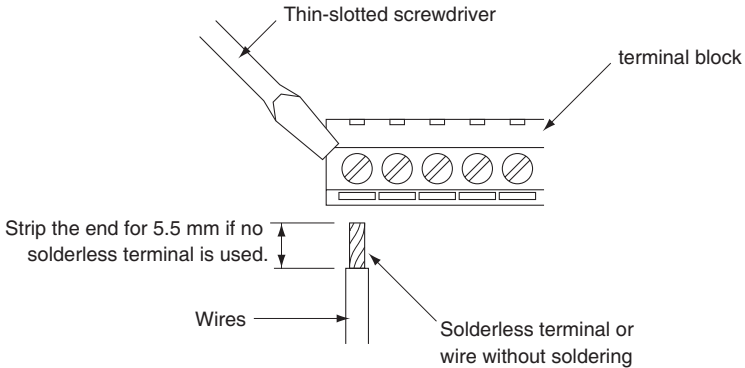

- ※ Applying a torque of greater than  $0.5 \text{ N} \cdot \text{m}$  may damage the terminal block. If the tightening torque is insufficient, however, wires may be disconnected.

## Section 2 Design

### 2-2-6 Conforming to EC Directives

The following description provides the wiring method of the Inverter to meet EC Directive requirements. If the following requirements are not satisfied, the whole equipment incorporating the Inverter will need further confirmation.

#### ■ Standard Connection

##### ● Main Circuit Terminals

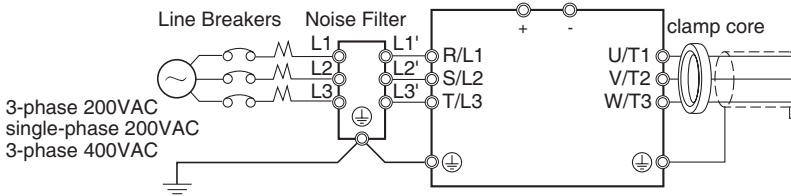

##### ● Control Circuit Terminals

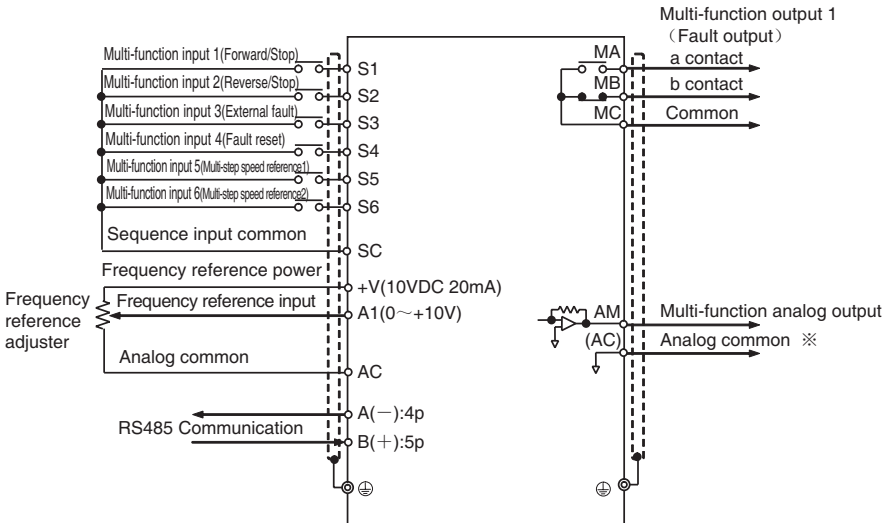

※ I/O signals can be connected to a single shielded cable. The analog output is a PWM wave which the carrier frequency is 1KHz, and it could connect to Analog input directly.

## ■ Conforming to EMC Directives

### ● Wiring the Power Supply

Make sure that the Inverter and Noise Filter are grounded together.

- Always connect the inverter's (200 V AC) power input terminals (R/L1, S/L2, and T/L3) and power supply via a dedicated Noise Filter.
- Reduce the length of the ground wire as much as possible.
- Locate the Noise Filter as close as possible to the Inverter. Make sure that the cable length between the Noise Filter and the Inverter does not exceed 40 cm.

### ● Connecting a Motor to the Inverter

- When connecting a motor to the Inverter, be sure to use a cable with a braided shield.
- Reduce the length of the cable as short as possible and ground the shield on the Inverter side as well as the motor side. Make sure that the cable length between the Inverter and the motor does not exceed 20 m. Furthermore, it is recommended that a clamp core (Clamp Filter) be connected close to the output terminals of the Inverter.

Product	Model	Manufacturer
Clamp Filter	ZCAT3035 — 1330	TDK

### ● Wiring a Control Cable

- Be sure to connect a cable with a braided shield to the control circuit terminals.
- Ground the shield on the Inverter side only.

### ● Grounding the Shield

In order to ground the shield securely, it is recommended that a cable clamp be directly connected to the ground plate as shown below.

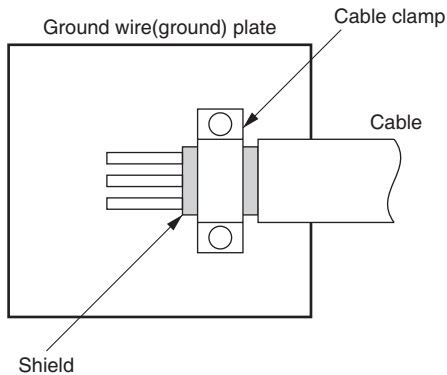

## Section 2 Design

---

### ■ Conforming to LVD(Low-voltage Directive)

- Always connect the Inverter and power supply via a molded case circuit breaker (MCCB) suitable to the Inverter for protecting the Inverter from damage that may result from short-circuiting.
- Use one MCCB per Inverter.
- Select a suitable MCCB from the following table.

#### ● Single-phase 200VAC

Model 3G3JZ-	Type	MCCB Rated current [A]
AB002	NF30	5A
AB004		10A
AB007		20A
AB015		20A
AB022		40A

#### ● 3-phase200VAC

Model 3G3JZ-	Type	MCCB Rated current [A]
A2002	NF30	5A
A2004		5A
A2007		10A
A2015		20A
A2022		20A
A2037		30A

#### ● 3-phase400VAC

Model 3G3JZ-	Type	MCCB Rated current [A]
A4004	NF30	5A
A4007		5A
A4015		10A
A4022		10A
A4037		20A

※ To satisfy LVD (Low-voltage Directive) requirements, the system must be protected by a molded case circuit breaker (MCCB) when a short-circuit occurs. A single MCCB may be shared with more than one Inverter or with other machines. In that case, however, take some appropriate measures so that the MCCB will protect all the Inverters from the occurrence of any single short-circuit.

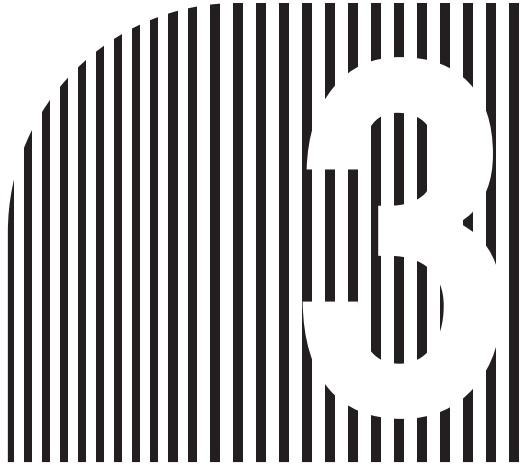

# Chapter 3

● Operation • Monitoring ●

- 3-1 Operation for Digital Operator
- 3-2 Monitor Function of Digital Operator

# Chapter 3 Operation • Monitoring

## 3-1 Operation for Digital Operator

### 3-1-1 Nomenclature and functions



	Name	Function
	Data display	Displays relevant data items, such as frequency command, output frequency, and parameter set values.
	Frequency adjuster	Sets the frequency adjuster within a range between 0 Hz and the maximum frequency.
<b>RUN</b> •	RUN indicator	Lights in operation. Flashes when run command is turned OFF and in deceleration.
<b>FWD</b> •	FWD indicator	Lights when executing a FWD command. Flashes when switching from FWD to REV.
<b>REV</b> •	REV indicator	Lights when executing a REV command. Flashes when switching from REV to FWD.
<b>STOP</b> •	STOP indicator	Lights when stopped. Flashes when running at a frequency which is lower than minimum output frequency.
•	(Carry indicator)	Lights when displaying first 4 of 5 digits of the parameter.
	Mode Key	Switches the inverter's monitor display in sequence. Parameter setting being made is canceled if this key is pressed before entering the setting.
	Enter Key	Enters parameter edit mode when pressed in monitor display status. Used when determining parameter No. and displaying parameter set value. In addition, press this button to confirm the parameter change.
	Decrement Key	Decrease the frequency command, the value of constant parameter No. and setting value of constant parameter
	Increment Key	Increase the frequency command, the value of constant parameter No. and setting value of constant parameter
	RUN Key	Starts the Inverter running when the 3G3JZ is in operation with the Digital Operator.
	STOP/RESET Key	Stops the Inverter unless parameter n2.01 is set to enable the STOP Key. Used to reset the Inverter when an error occurs. ※

※ For safety reasons, the reset function cannot be used while an operation command (forward/reverse) is being input. Turn the operation command OFF before using this function.

## 3-1-2 Outline of Operation

## ■ Switch Between the Modes

Press Mode Key (◻) to switch data display.

When the power is turned ON, the data of frequency command "F0.0", output frequency "H0.0" and output current "A0.0" switch as below.

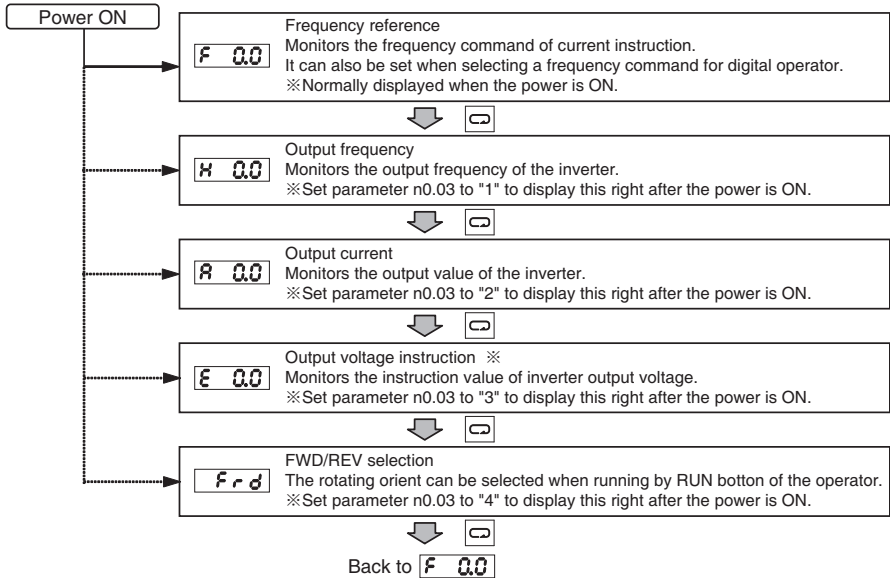

※ When the monitoring of output voltage command is displayed in parameter n0.04 (monitor display item selection), the content to be displayed can be changed.

■ Example of Parameter Settings

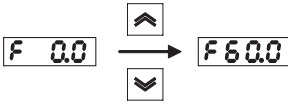

Key sequence	Data display	Explanation
—		Frequency commands can be changed in all viewable monitor modes. Eg. Monitoring the output current. ※ However, frequency command can not be changed when displaying FWD/REV selection.
		Press Increase Key or Decrease Key to switch to frequency command and set it. The changed value is reflected by frequency command. ※ It is not necessary to operate the input keys when changing the frequency command.

※ 1. Only in following cases, you can change frequency command by digital operator.

- Set n2.00 (frequency selection) to "0" (operator's Increase/Decrease key inputs are valid), and multi-speed command or second frequency command has not been input yet
- Set n2.09 (second frequency selection) to "0" (operator's Increase/Decrease key inputs are valid), second frequency command has been input but multi-speed command has not been input yet.

※ 2. Frequency command can be changed in operation.

■ Example of Forward/Reverse Selection Settings

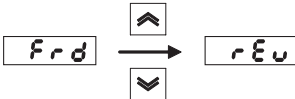

Key sequence	Display example	Explanation
		Press the Mode Key repeatedly until the F/R indicator is lit. : Forward  4-1
		Use the Increment or Decrement Key to change the direction of motor rotation. (The direction of motor rotation selected will be enabled when the display changes after the key is pressed.)

※ 1. Select the rotating orient when run by the RUN Key of the operator. This function is disabled in other operation commands.

※ 2. The direction of motor rotation can be changed, even during operation.

### ■ Example of Parameter Settings

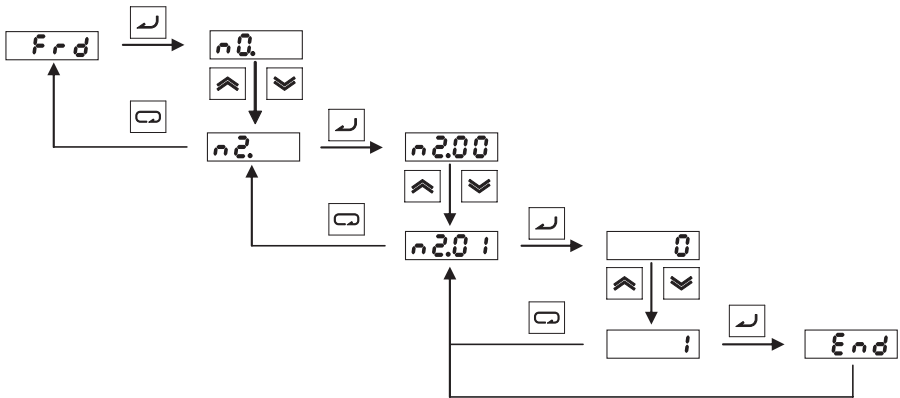

Key sequence	Data display	Explanation
↵	n0.	Press Enter Key in any mode to switch to parameter setting mode.
↓ ↑	n2.	Select the required parameter group No. by pressing Increase/Decrease Key. ※ 1
↵	n2.00	Press the Enter Key. The data of the selected parameter number will be displayed.
↓ ↑	n2.01	Select the required parameter No. by pressing Increase/Decrease Key. ※ 1
↵	0	Press the Enter Key so that the set value will be entered and the data display will be lit.
↓ ↑	1	Select the required setting value by pressing Increase/Decrease Key. ※ 1
↵	End	End will be displayed for 1s after pressing Enter Key to confirm the set value.
In approximately 1 s.	n2.01	The parameter number will be displayed in approximately 1 s.

- ※ 1. To cancel the set value and go back to the previous step, press the Mode Key (⏏) instead.
- ※ 2. There are parameters that cannot be changed while the Inverter is in operation. Refer to the list of parameters. When attempting to change such parameters, [Err] will be displayed and set values are canceled.
- ※ 3. If you set to disable any parameter change or protected by password, when you set the parameter, [Err] will be displayed and the set value is ignored.

## 3-2 Monitor Function of Digital Operator









### 3-2-1 Monitor display selection

- An inverter has 5 viewable monitoring item. "Output voltage command" can be changed to other items by parameter setting.

n0.04	Monitor display item selection	Register No.	0004	Changes during operation	○
Setting Range	0 ~ 11	Unit of setting	1	Default Setting	4

- Monitor items you want to display when confirming inverter operation or device operation are set as below.

#### 【Set value explanation】

Set value	Example of display	Name	Details
0		Custom monitor	User-faced monitor display. Used to display the data conformed to the device. Set the multiple of output frequency as your wish in n0.05.
1	--	(Not used)	--
2	--	(Not used)	--
3		Main circuit DC voltage	Displays main circuit DC voltage inside the inverter in VDC.
4		Output voltage command	Displays voltage command value output by the inverter in VAC.
5	--	(Not used)	--
6		Output side power factor angle	Displays power factor angle of the inverter in degree.
7		Electric power output	Displays electric power output of the inverter in kW.
8	--	(Not used)	--
9		Frequency command (voltage) A1 terminal input voltage	When A1 is enabled to be used as 1st or 2nd frequency command, input voltage 0 to 10 VDC in A1 terminal is displayed as 0.0 to 10.0, in the unit of 0.1 V. Displayed as 0.0 when it is disabled.
10		Frequency command (current) A1 terminal input current	When A1 is enabled to be used as 1st or 2nd frequency command, input current 4 to 20 mA in A1 terminal is displayed as 4.0 to 20.0, in the unit of 0.1 mA. Displayed as 0.0 when it is disabled. ※ Input voltage 0 to 10 VDC is displayed as 0.0 to 10.0 when the voltage is input, in the unit of 0.1 V.
11		IGBT temperature	The temperature of inverter inner output transistor (IGBT) is displayed in °C.

n0.05	Custom monitor	Register No.	0005	Changes during operation	○
Setting range	0.1 ~ 160.0	Unit of setting	0.1	Default setting	1.0

#### 【Default setting】

- User-faced monitor display which matches the device. Set the variation multiple as your wish in inverter output frequency.
- Example of setting  
Setting: 2.0

Output frequency 60.0Hz × set value 2.0 = 120 → 





## 3-2-2 Display selection when power is ON

- When the inverter power is ON, you may select a monitor item to be displayed from 5.

n0.03	Monitor display selection when power is ON	Register No.	0003	Changes during operation	○
Setting range	0 ~ 4	Unit of setting	1	Default setting	0

- Select a monitor item from 5, or change voltage monitoring into other monitoring and display it when the power is ON in Monitor Display Item (n0.04).

## 【Set value explanation】

Set value	Example of monitor display	Name	Details
0		frequency command	Displays frequency command after the power is turned ON. This is the default setting.
1		Output frequency	Displays output frequency after the power is turned ON.
2		Output current	Displays output current after the power is turned ON.
3		Output voltage command	Displays output voltage command after the power is turned ON. ※ This monitor display can be changed in parameter n0.04 (monitor display item).
4		FWD/REV selection	Select to display FWD or REV after the power is turned ON.

## Chapter 3 Operation • Monitoring

### 3-2-3 Monitor function in parameter setting

Except for the 5 display switched by Mode Key, there are more monitor functions in parameter setting area.

The following table contains this monitor function in detail, please reference when you are setting or tuning the device.

The following functions can be confirmed with the parameter setting of the table.

Setting No.	Register No. [Hex]	Name	Details																																								
n0.00	0000	Inverter capacity monitor ※ For reference only	<p>Following are the inverter's power supply specifications and capacity monitoring of different models. Specifications/capacity available for each inverter is as below.</p> <table border="1"> <thead> <tr> <th>Display</th> <th>Power supply specification/capacity</th> <th>Display</th> <th>Power supply specification/capacity</th> </tr> </thead> <tbody> <tr> <td>0</td> <td>Single-phase/3-phase 200 VAC/0.2 kW</td> <td>9</td> <td>3-phase 400 VAC/2.2 kW</td> </tr> <tr> <td>1</td> <td>(Not used)</td> <td>10</td> <td>Single-phase/3-phase 200 VAC/3.7 kW</td> </tr> <tr> <td>2</td> <td>Single-phase/3-phase 200 VAC/0.4 kW</td> <td>11</td> <td>3-phase 400 VAC/3.7 kW</td> </tr> <tr> <td>3</td> <td>3-phase 400 VAC/0.4 kW</td> <td></td> <td></td> </tr> <tr> <td>4</td> <td>Single-phase/3-phase 200 VAC/0.75 kW</td> <td></td> <td></td> </tr> <tr> <td>5</td> <td>3-phase 400 VAC/0.75 kW</td> <td></td> <td></td> </tr> <tr> <td>6</td> <td>Single-phase/3-phase 200 VAC/1.5 kW</td> <td></td> <td></td> </tr> <tr> <td>7</td> <td>3-phase 400 VAC/1.5 kW</td> <td></td> <td></td> </tr> <tr> <td>8</td> <td>Single-phase/3-phase 200 VAC/2.2 kW</td> <td></td> <td></td> </tr> </tbody> </table>	Display	Power supply specification/capacity	Display	Power supply specification/capacity	0	Single-phase/3-phase 200 VAC/0.2 kW	9	3-phase 400 VAC/2.2 kW	1	(Not used)	10	Single-phase/3-phase 200 VAC/3.7 kW	2	Single-phase/3-phase 200 VAC/0.4 kW	11	3-phase 400 VAC/3.7 kW	3	3-phase 400 VAC/0.4 kW			4	Single-phase/3-phase 200 VAC/0.75 kW			5	3-phase 400 VAC/0.75 kW			6	Single-phase/3-phase 200 VAC/1.5 kW			7	3-phase 400 VAC/1.5 kW			8	Single-phase/3-phase 200 VAC/2.2 kW		
Display	Power supply specification/capacity	Display	Power supply specification/capacity																																								
0	Single-phase/3-phase 200 VAC/0.2 kW	9	3-phase 400 VAC/2.2 kW																																								
1	(Not used)	10	Single-phase/3-phase 200 VAC/3.7 kW																																								
2	Single-phase/3-phase 200 VAC/0.4 kW	11	3-phase 400 VAC/3.7 kW																																								
3	3-phase 400 VAC/0.4 kW																																										
4	Single-phase/3-phase 200 VAC/0.75 kW																																										
5	3-phase 400 VAC/0.75 kW																																										
6	Single-phase/3-phase 200 VAC/1.5 kW																																										
7	3-phase 400 VAC/1.5 kW																																										
8	Single-phase/3-phase 200 VAC/2.2 kW																																										
n0.06	0006	Software No. ※ For reference only	Displays version information of the software used in driving section.																																								
n6.08	0608	Abnormal log 1 (once ago)	<p>When the inverter is faulty, system may record at most 2 information about the fault to analyse the cause. Operation fault information is logged in the following codes. ※ For reference only</p> <table border="1"> <thead> <tr> <th>No.</th> <th>Function</th> <th>No.</th> <th>Details</th> </tr> </thead> <tbody> <tr> <td>0</td> <td>(No faults)</td> <td>21</td> <td>Overvoltage detected circuit fault"HPF2"</td> </tr> <tr> <td>1</td> <td>Over current (hardware detected)"oc"</td> <td>22</td> <td>Ground detected circuit fault"HPF3"</td> </tr> <tr> <td>2</td> <td>Over voltage "ov"</td> <td>23</td> <td>Overcurrent detected circuit fault"HPF4"</td> </tr> <tr> <td>3</td> <td>Heat sink overheated "oH1"</td> <td>24</td> <td>U-phase circuit fault"cf3.0"</td> </tr> <tr> <td>4</td> <td>Power supply board overheated "oH2"</td> <td>25</td> <td>V-phase circuit fault"cf3.1"</td> </tr> <tr> <td>5</td> <td>Inverter overload"oL"</td> <td>26</td> <td>W-phase circuit fault"cf3.2"</td> </tr> <tr> <td>6</td> <td>Motor overload"oL1"</td> <td>27</td> <td>Voltage control circuit fault"cf3.3"</td> </tr> <tr> <td>7</td> <td>Overtorque detected"oL2"</td> <td>28</td> <td>Temperature detector 1 fault"cf3.4"</td> </tr> </tbody> </table>	No.	Function	No.	Details	0	(No faults)	21	Overvoltage detected circuit fault"HPF2"	1	Over current (hardware detected)"oc"	22	Ground detected circuit fault"HPF3"	2	Over voltage "ov"	23	Overcurrent detected circuit fault"HPF4"	3	Heat sink overheated "oH1"	24	U-phase circuit fault"cf3.0"	4	Power supply board overheated "oH2"	25	V-phase circuit fault"cf3.1"	5	Inverter overload"oL"	26	W-phase circuit fault"cf3.2"	6	Motor overload"oL1"	27	Voltage control circuit fault"cf3.3"	7	Overtorque detected"oL2"	28	Temperature detector 1 fault"cf3.4"				
No.	Function	No.		Details																																							
0	(No faults)	21	Overvoltage detected circuit fault"HPF2"																																								
1	Over current (hardware detected)"oc"	22	Ground detected circuit fault"HPF3"																																								
2	Over voltage "ov"	23	Overcurrent detected circuit fault"HPF4"																																								
3	Heat sink overheated "oH1"	24	U-phase circuit fault"cf3.0"																																								
4	Power supply board overheated "oH2"	25	V-phase circuit fault"cf3.1"																																								
5	Inverter overload"oL"	26	W-phase circuit fault"cf3.2"																																								
6	Motor overload"oL1"	27	Voltage control circuit fault"cf3.3"																																								
7	Overtorque detected"oL2"	28	Temperature detector 1 fault"cf3.4"																																								
n6.09	0609	Abnormal log 2 (twice ago)																																									

Setting No.	Register No. [Hex]	Name	Details			
			No.	Function	No.	Details
			8	External fault "EF"	29	Temperature detector 2 fault "cF3.5"
			9	Overcurrent in acceleration "ocA"	32	Multi-function analog input signal error "AErr"
			10	Overcurrent in deceleration "ocd"		
			11	Overcurrent in normal status "ocn"		
			12	Ground "GFF"		
			13	Main circuit low voltage "Lv" ※ Not recorded.		
			14	Input power supply phase loss "PHL"		
			15	External base pole blockade "bb" ※ ※ Not recorded.		
			18	EEPROM(PB) write fault "cF1.0"		
			19	EEPROM(PB) read fault "cF2.0"		
			20	Current limit circuit fault "HPF1"		

※ 13: Main circuit low voltage "Lv" and 15: external base pole blockade "bb" will not be written to fault log.



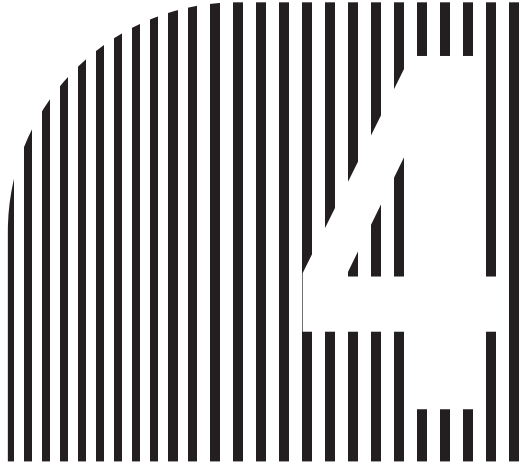



## Chapter 4

### ● Test Run ●

- 4-1 Procedure for Test Run
- 4-2 Operation for Test Run

# Chapter 4 Test Run

## Caution

Provide an external emergency stopping device that allows an instantaneous stop of operation and power interruption. Not doing so may result in injury.	
Do not open terminal case when power is being supplied or power has just been turned OFF for less than 10 minutes. Doing so may occasionally result in minor injury due to electric shock.	
Do not touch the radiating fan when power is being supplied or power has just been turned OFF for a short period. Doing so may occasionally result in scald due to high temperature.	

### Safety Precautions

- (1) About operation and maintenance
1. This product can be set from low speed to high speed, please check the permissible range of the motor device being used before operating.
  2. To avoid dropping of the vertical load, please confirm the operation after setting and wiring before using external brake output. Doing so may occasionally result in minor injury.

### Precautions

- (1) About the operation after resetting from momentary power OFF  
If you select continue operating in Operation Selection after Momentary Rest (n8.04), The inverter will restart suddenly after the power is reset. Please pay attention.

(2) About operation command selection

In following cases, unexpected operation may take place in the motor, please perform after ensuring the security.

- Operation command selection (n2.01) is set to control circuit terminal, operation selection after power supply putting in/operation command switching (n2.05) is set to enable, turn ON the power when there are operation signals.
- Multi-function input (n4.05 to n4.08) is set to operation command switch, operation selection after power supply putting in/operation command switching (n2.05) is set to enable, switch to other operation commands when there are some operation signals.
- Fault retry times (n8.15) is set to enable, auto resetting from faulty stop.
- Verify the signal when power is being supplied, apply an incorrect voltage to control input terminal.

## 4-1 Procedure for Test Run

Item	Details	Reference
Installation•Mounting	Install the Inverter according to the installation conditions. • Ensure that the installation conditions are met.	Page 2-1
Wiring•Connection	Connect to the power supply and peripheral devices. • Select peripheral devices which meet the specifications and wire correctly.	Page 2-15
Power Connection	Carry out the following pre-connection checks before turning on the power supply. • Always ensure that a power supply to the correct voltage is used and that the power input terminals (R/L1, S/L2, and T/L3) are wired correctly. 3G3JZ — AB □ : Single-phase AC200 ~ 240V (Wire R/L1 and S/L2) 3G3JZ — A2 □ : 3-phase AC200 ~ 240V 3G3JZ — A4 □ : 3-phase AC380 ~ 480V • Make sure that the motor output terminals (U/T1, V/T2, and W/T3) are connected to the motor correctly. • Ensure that the control circuit terminals and the control device are wired correctly. Make sure that all control terminals are turned off. • Set the motor to no-load status (i.e., not connected to the mechanical system). • Having conducted the above checks, connect the power supply.	
Check the Display Status	Check to be sure that there are no faults in the Inverter. • If the display at the time the power is connected is normal, it will read as follows: frequency command display of $\boxed{F000}$ • When a fault has occurred, the details of the fault will be displayed. In that case, refer to Chapter 8 Maintenance Operations and take necessary remedies.	
Initializing Parameters	Initialize the parameters. • Set n0.02 to 9 (initialization at 50 Hz max.) to initialize the parameters.	
Setting Parameters	Set the parameters required for a test run. • Set the rated motor current in order to prevent the motor from burning due to overloading.	
No-load Operation	Start the no-load motor using the Digital Operator. • Set the frequency command using the Digital Operator and start the motor using key sequences.	
Actual Load Operation	Connect the mechanical system and operate using the Digital Operator. • When there are no difficulties using the no-load operation, connect the mechanical system to the motor and operate using the Digital Operator.	
Operation	Basic Operation (operation based on the basic settings required to start and stop the Inverter.)	Page 5-1
	Advanced Operation (stall prevention etc.)	Page 6-1
	• For operation within standard parameters, refer to Chapter 5 Basic Operation. • Refer to Chapter 5 Basic Operation and Chapter 6 Advanced Operation for the various advanced functions, such as stall prevention, carrier frequency setting, overtorque detection, torque compensation, and slip compensation	

## 4-2 Operation for Test Run

### 1 Power Connection

#### ■ Checkpoints before Connecting the Power Supply

- Check that the power supply is of the correct voltage and that the motor output terminals (R/L1, S/L2, and T/L3) are connected to the motor correctly.

3G3JZ — AB □ : Single-phase AC200 ~ 240V (Wire R/L1 and S/L2)

3G3JZ — A2 □ : 3-phase AC200 ~ 240V

3G3JZ — A4 □ : 3-phase AC380 ~ 480V

- Make sure that the motor output terminals (U/T1, V/T2, and W/T3) are connected to the motor correctly.
- Ensure that the control circuit terminals and the control device are wired correctly. Make sure that all control terminals are turned off.
- Set the motor to no-load status (i.e., not connected to the mechanical system).

#### ■ Connecting the Power Supply

- After conducting the above checks, connect the power supply.

### 2 Check the Display Status

- If the display is normal when the power is connected, it will read as follows:

【Normal】 frequency command display of F 0.0

- When a fault has occurred, refer to Chapter 8 Maintenance Operations and take necessary action.

【Fault】 L.v Display error (Lv: main circuit low voltage) etc

### 3 Initializing Parameters

- Initialize the parameters using the following procedure.
- To initialize the parameters, set n0.02 to 9. (initialization at 50 Hz max.)  
 ※ To initialize the parameters at 60 Hz max., set n0.02 to 10. (initialization at 60 Hz max.)



















n0.02	Parameter write disable option/parameter initialization	Register No.	0002	Changes during operation	×
Setting range	0 ~ 10	Unit of setting	1	Default setting	0

Key sequence	Display example	Explanation
	<span style="border: 1px solid black; padding: 2px;">n0.</span>	Press enter key to switch to parameter setting mode.
	<span style="border: 1px solid black; padding: 2px;">n0.</span>	N0.02 (parameter write disable option/parameter initialization) is group n0, so you need to press increasement key or decreaseement key to select group n0. ※ n0 is displayed when power is ON.
	<span style="border: 1px solid black; padding: 2px;">n000</span>	Press the Enter Key. The data of selected group will be displayed.
	<span style="border: 1px solid black; padding: 2px;">n002</span>	Press increasement key or decreaseement key to select n0.02 (parameter write disable option/parameter initialization).
	<span style="border: 1px solid black; padding: 2px;">0</span>	Press enter key again to display the setting value of the parameter.
	<span style="border: 1px solid black; padding: 2px;">9</span>	Press increasement key or decreaseement key to select "9" as the set value.
	<span style="border: 1px solid black; padding: 2px;">End</span>	After confirmation of the sett value by pressing enter key, End will be displayed for 1 second.
In approximately 1s.	<span style="border: 1px solid black; padding: 2px;">F 0.0</span>	frequency command is displayed in approximately 1s. ※ After the parameter is set, parameter number will be displayed normally. Only after initialization, the frequency command will be displayed.

#### 4 Setting the parameter

- Set the rated motor current parameter in n7.00 in order to prevent the motor from burning due to overloading.
- Set motor current according to the rated current value printed on the motor's nameplate.

n7.00	Rated Motor Current	Register No.	0700	Changes during operation	○
Setting range	0.6 ~ 1.9 ※ 1	Unit of setting	0.1%	Default setting	1.2 ※ 2

Key sequence	Display example	Explanation
		Press enter key to switch to parameter setting mode.
 		n7.00 (motor's rated current) is group n7, you need to press increase key or decrease key to select group n7.
		Press enter key, display parameters of selected group.
 		Press increase key or decrease key again to select n7.00 (motor's rated current).
		Press enter key again, setting data of the parameter will be displayed.
 		Press increase key or decrease key to set motor's rated current. ※ Set value must be higher than n7.01 (motor's no load current)
		After confirmation of the sett value by pressing enter key, End will be displayed for 1 second.
In approximately 1 s.		The parameter number will be displayed in approximately 1 s.











※ 1.Motor's rated current setting range depends on the type of the inverter. It can be set within 30% to 120% of inverter's rated output current.

※ 2.Motor's rated current initial setting depends on the type of the inverter. It is normally set to 75% of the rated output current.

#### 5 No-load Operation

- Start the no-load motor (i.e., not connected to the mechanical system) using the Digital Operator.
  - ※ Before operating the Digital Operator, check that the frequency adjuster is set to MIN.

##### ■ Forward/Reverse Rotation with the Digital Operator

Key sequence	Display example	Explanation
		Press the Mode Key to turn on the FREF indicator. Confirm the frequency command is "0.0" from display.
		Press RUN key. 「RUN ●」 LED lit, while 「STOP ●」 flashes.
		Turn the frequency adjuster slowly, frequency command monitor value will be displayed in data display. The motor starts FWD operation according to the frequency command. ※ When the frequency command is lower than the minimum value, 「STOP ●」 is turned OFF.
		Press Mode Key to display FWD/REV selection.
 		Motor's rotating orient changes when you've pressed increase/decrease key. (Changing display by pressing the button will change the rotating orient immediately) ※ 「FWD ●」 lights in FWD operation. 「REV ●」 lights in REV operation. 「FWD ●」 flashes when decelerating in FWD operation.

## Chapter 4 Test Run

---

- Turn the frequency adjuster to confirm there is no vibration and noise in the motor.
- Check that no faults have occurred in the Inverter during operation.

### ■ Stopping the Motor

- On completion of operating the motor in the no-load state in the forward or reverse direction, press the STOP/RESET Key. The motor will stop.

6

### Actual Load Operation

- After checking the operation with the motor in no-load status, connect the mechanical system and operate with an actual load.

※ Before operating the Digital Operator, check that the frequency adjuster is set to MIN.

### ■ FWD/REV operation of Digital Operator

- After confirming that the motor has stopped completely, connect the mechanical system.
- Be sure to tighten all the screws when fixing the motor axis in the mechanical system.

### ■ Operation Using the Digital Operator

- In case a fault occurs during operation, make sure the STOP/RESET Key on the Digital Operator is easily accessible.
- Use the Digital Operator in the same way as no-load operation.
- First set the frequency to a low speed of one tenth the normal operating speed.

### ■ Checking the Operating Status

- Having checked that the operating direction is correct and that the machine is operating smoothly at slow speed, increase the frequency.
- After changing the frequency or the rotation direction, check that there is no vibration or abnormal sound from the motor.

Finally check the output current (8.4.4 display).

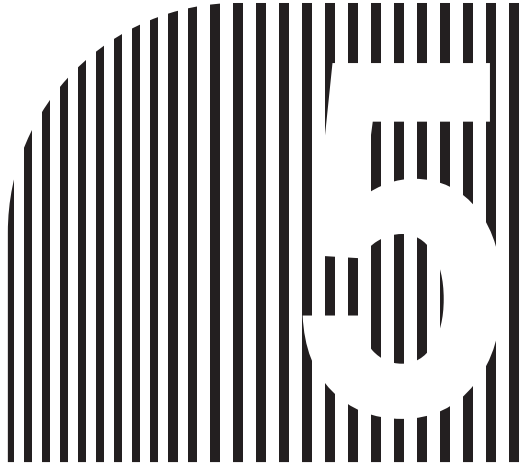

## Chapter 5

### ● Basic Operation ●

- 5-1 Initial Settings
- 5-2 Operation in V/f Control
- 5-3 Selecting the Operation Command
- 5-4 Setting the Frequency Command
- 5-5 Setting the Acceleration/Deceleration Time
- 5-6 Selecting the Reverse Rotation-prohibit
- 5-7 Selecting the Stopping Method
- 5-8 Multi-function I/O
- 5-9 Multi-function Analog Output

# Chapter 5 Basic Operation

This section explains the basic settings required to operate and stop the inverter.

The settings of parameters described here will be sufficient for simple Inverter operations.

First make these basic settings and then skip to the application functions, such as slip compensation, torque compensation, carrier frequency setting, energy-saving control, internal input setting of input terminal, operation timing of external stopper, overtorque detection, DC brake, stall prevention. Refer to Chapter 6 Advanced Operation.

## 5-1 Initial Settings

- The following 2 initial settings are required.

Initialize the parameter by setting the parameter Write-prohibit Selection/Parameter Initialization (n0.02) to “9” or “10”.

### 5-1-1 Initialization of the Parameters (n0.02)

Firstly, initialize the parameters to avoid the affection of the parameters set before.

n0.02	Parameter Write-prohibit Selection/ Parameter Initialization	Register No.	0002	Changes during operation	×
Setting range	0 ~ 10	Unit of setting	1	Default setting	0

- This inverter has “9” (initialization when the maximum frequency is 50 Hz) and “10” (initialization when the maximum frequency is 60 Hz), perform the initialization according to the rated frequency of the motor you are using.
- The write of all parameters can be prohibited.
- Do not set the values not used (2-7).

#### 【Explanation of the setting values】

Setting value	Description
0	Applied to all the parameter settings and references.
1	Only n0.02 can be set (Parameter Write-prohibit Selection/Parameter Initialization). All the other parameters can be used as references only. ※ Even if the setting value of write-prohibite parameters is changed, the Err setting value will be ignored.
2-7	(Not used) ※ Do not set the values not used.
8	keys lock
9	Initialization when the maximum frequency is 50 Hz ※ Perform the initialization with 50.00Hz as n1.00 (the maximum frequency) and n1.01 (the maximum voltage frequency).
10	Initialization when the maximum frequency is 60 Hz ※ Perform the initialization with 60.00Hz as n1.00 (the maximum frequency) and n1.01 (the maximum voltage frequency).

## 5-2 Operation under V/f status

This mode, which is used by conventional general-purpose inverters, is convenient when replacing a conventional model with 3G3JZ Inverter because the Inverter in this mode can be operated without considering the constants of the motor.

To operate the Inverter in V/f control mode, be sure to set n7.00 (rated motor current) and n1.00 - n1.06 (V/f mode).

### 5-2-1 Setting rated motor current (n7.00)

Check the the motor nameplate and set this parameter to the rated current.

This set value is used for determining the electronic thermal characteristics to protect the motor from overheating. The correct set value protects the motor from burning that may result from overloading.

n7.00	Rated Motor Current	Register No.	0700	Changes during operation	○
Setting range	30% ~ 120% ※ 1	Unit of setting	0.1	Default setting	75% ※ 2

• Set the rated motor current on motor nameplate in A increments.

※ 1. The setting range of rated motor current differs according to inverter models. The setting can be made between 30% and 120% of inverter's rated output current approximately.

※ 2. The default setting of rated motor current differs according to inverter models. Set the value to the 75% of inverter's rated output current approximately.

※ 3. When several motors are connected to one inverter, the electronic thermal characteristics protecting the motor from overheating will not run normally. Set n6.06 (motor protection selection) = 2 to disable electronic thermal function, then set thermal protection devices outside every motor.

### 5-2-2 Setting V/f Patterns (n1.00 ~ n1.06)

Set the V/f pattern so that the motor output torque is adjusted to the required load torque.

SYSDRIVE 3G3JZ incorporates an automatic torque boost function. Therefore, a maximum of 150% torque can be output at 3 Hz without changing the default setting. Check the system in trial operation and leave the default settings as they are if no torque characteristic changes are required.

n1.00	Maximum Frequency(FMAX)	Register No.	0100	Changes during operation	×
Setting range	50.00 ~ 600.0	Unit of setting	0.01Hz	Default setting	50.00
n1.01	Maximum Voltage Frequency(FA)	Register No.	0101	Changes during operation	×
Setting range	0.10 ~ 600.0	Unit of setting	0.01Hz	Default setting	50.00
n1.02	Maximum Voltage(VMAX)	Register No.	0102	Changes during operation	×
Setting range	0.1 ~ 255.0(0.1 ~ 510.0)	Unit of setting	0.1V	Default setting	200.0(400.0)
n1.03	Middle Output Frequency(FB)	Register No.	0103	Changes during operation	×
Setting range	0.10 ~ 600.0	Unit of setting	0.01Hz	Default setting	1.50
n1.04	Middle Output Frequency Voltage(VC)	Register No.	0104	Changes during operation	×
Setting range	0.1 ~ 255.0(0.1 ~ 510.0)	Unit of setting	0.1V	Default setting	12.0(24.0)
n1.05	Minimum Output Frequency(FMIN)	Register No.	0105	Changes during operation	×
Setting range	0.10 ~ 600.0	Unit of setting	0.01Hz	Default setting	1.50
n1.06	Minimum Output Frequency Voltage(VMIN)	Register No.	0106	Changes during operation	×
Setting range	0.1 ~ 255.0(0.1 ~ 510.0)	Unit of setting	0.1V	Default setting	12.0(24.0)

## Chapter 5 Basic Operation

- Set the minimum frequency applied on the motor in n1.05 according to the applied minimum speed. The frequency lower than n1.05 setting value is disabled, the inverter will block the output and the motor will not rotate.
  - The vertical-axis load or the load with high viscous friction may require high torque at low speed. If the torque is insufficient at low speed, increase the voltage in the low-speed range by 1 V, provided that no overload (OL1 or OL2) is detected. If an overload is detected, decrease the set values or consider the use of an Inverter model with a higher capacity.
  - Under fan control or pump control, because the necessary torque is in proportion of the second power or third power of speed, setting the V/f mode with quadratic (cubic) function to lower the voltage in low speed area will help save energy.
- ※ The values in the parentheses are setting range and Default settings of 400VAC inverter.

### 【Explanation of the setting values】

Output voltage [V]

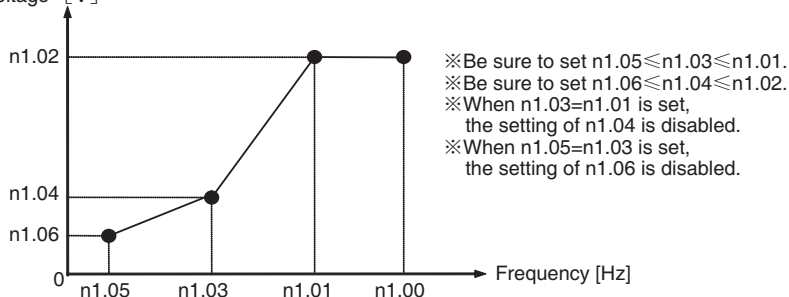

### 5-3 Selecting Operation Command

The following description provides information on how to input operation commands to start or stop the Inverter or change the direction of rotation of the Inverter.

Four types of command input methods are available. Select either one of them according to the application.

#### 5-3-1 Selecting Operation Command (n2.01)

Select the method of operation mode input to start or stop the Inverter according to the application.

n2.01	Operation Command Selection	Register No.	0201	Changes during operation	○
Setting range	0 ~ 4	Unit of setting	1	Default setting	0

- Make a choice from 5 methods to input inverter operation/stop command.

#### 【Explanation of the setting values】

Setting value	Description
0	The RUN/STOP key of the operator is enabled
1	Control circuit terminals (2- or 3-wire sequence) is enabled (The STOP key in operator is also enabled)
2	Control circuit terminals (2- or 3-wire sequence) is enabled (The STOP key in operator is disabled)
3	The operation command from RS485 communication is enabled (The STOP key in operator is also enabled)
4	The operation command from RS485 communication is enabled (The STOP key in operator is disabled)

※ To set “18 (operation command switch: control terminals)”, “19 (operation command switch: operator)” and “20 (operation command switch: communication)” in multi-function input (n4.05-n4.08) to switch operation command temporarily.

After setting multiple operation command switches, the priority is as below. If all operation command switches are set to “ON”, the commands will be performed in the priority order, starting from control terminals.

n2.01 (Selecting operation command) < 20 (operation command switch: communication) < 19 (operation command switch: operator) < 18 (operation command switch: control terminals)

#### 5-3-2 Selecting Multi-function Input 1/2 Function (n4.04)

The input method of commands from control circuit terminals can be set when the operation command is set in control circuit terminals. Select the input method according to the application.

n4.04	Multi-function Input 1/2 Function (input terminal S1/S2) Selection	Register No.	0404	Changes during operation	×
Setting range	0 ~ 2	Unit of setting	1	Default setting	0

- It is enabled only if the input method of operation command is selected as control circuit terminal. Select the input method as control circuit terminal.

#### 【Explanation of the setting values】

Setting value	Description
0	2-wire sequence (terminal S1: forward rotation/stop, terminal S2: reverse rotation/stop)
1	2-wire sequence (terminal S1: run/stop, terminal S2: forward rotation/stop)
2	3-wire sequence ※ 1

※ If 3-wire sequence is set by setting n4.04 = 3, the setting of multi-function input 3 (n4.05) will be disabled, and 3-wire sequence will be assigned instead.

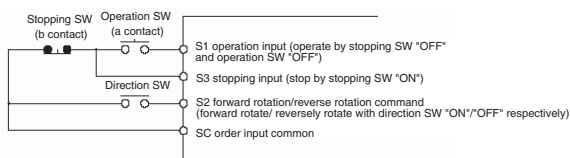

## Chapter 5 Basic Operation

### 5-3-3 Selecting Operation Frequency Command after Connecting power/Switching Operation Command (n2.05)

Select the operation command input before connecting power or switching operation command, and set if it is still enabled after connecting power or switching operation command.

Select according to the security and necessity of the application.

n2.05	Selecting operation after connecting power/ switching operation	Register No.	0205	Changes during operation	×
Setting range	0 ~ 3	Unit of setting	1	Default setting	1

- After connecting power/switching operation command, set if the operation command input before is enabled.

#### 【Explanation of the setting values】

Setting value	Description
0	Enabled after connecting power/ disabled after switching operation command
1	Disabled after connecting power/ disabled after switching operation command
2	Enabled after connecting power/ enabled after switching operation command
3	Disabled after connecting power/ enabled after switching operation command

※ When “enabled after connecting power or enabled after switching operation command” is set, the device may operate suddenly because of the input status of connecting power or switching operation command. Therefore, make preparations for the safety of the device.

※ When “disabled after connecting power or disabled after switching operation command” is set, unless input operation command again after connecting power or switching operation command, the inverter will not run.

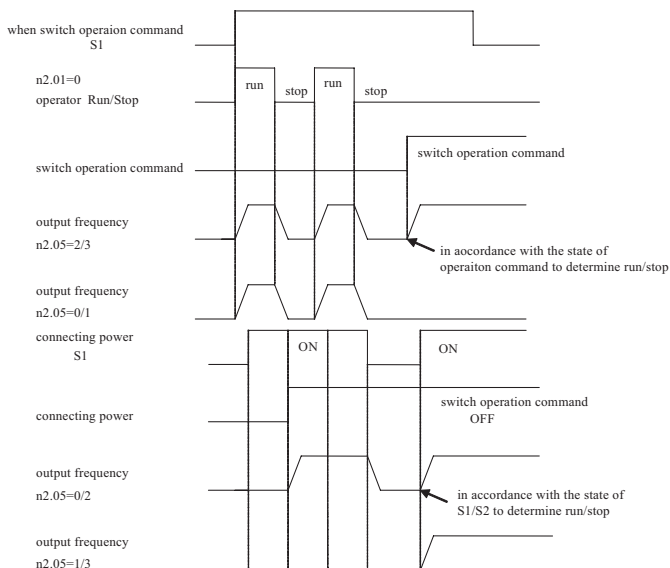

## 5-4 Setting the Frequency Command

This chapter explains the setting method of inverter's frequency command.

The input methods of frequency command for 3G3JZ series are as below. Select the applicable frequency command among them.

- The frequency command by using digital operator knob
  - The frequency command by using digital operator's digital setting
  - The frequency command with maximum speed 7-step speed frequency command by using multi-step speed command
  - The frequency command by using analog input
  - The frequency command by using UP/DOWN command
  - The frequency command from communication
- In addition, the frequency command can be switched. When some single frequency command input method can not be completed, use the frequency command switching function.

### 5-4-1 Selecting the Frequency Command (n2.00、n2.09、n2.10)

#### ■ Selecting frequency command/ Selecting the secondary frequency command

Select the method of inputting to inverter.

The operation consists of Selecting frequency command (n2.00) and Selecting the secondary frequency command (n2.09) (as auxiliary).

Selection of the secondary frequency command (n2.09) will be used when multiple frequency commands are needed. If single frequency command is needed, it will not be necessary to set this.

n2.00	Selecting Frequency Command	Register No.	0200	Changes during operation	○
Setting range	0 ~ 4	Unit of setting	1	Default setting	1
n2.09	Selecting the secondary Frequency Command	Register No.	0209	Changes during operation	○
Setting range	0 ~ 4	Unit of setting	1	Default setting	2

- Select the method of inputting to inverter.
- During selecting the secondary frequency command (n2.09), set the input method of the secondary frequency command. There are 2 methods for this.
  - ① Use n2.10 (selecting the secondary frequency command's operation) as auxiliary to input frequency command.
  - ② Set "22 (the secondary frequency command)" in multi-function input (n4.05-n4.08), and use frequency command and the secondary frequency command by switching each other.

#### 【Explanation of the setting values】

Setting value	Description
0	The input of operator increase/decrease key is enabled
1	The frequency command knob of operator is enabled ※ 1
2	Frequency command input terminal A1 (voltage input 0-10V) is enabled ※ 2
3	Multi-function analog input terminal A2 (current input 4-20mA) is enabled ※ 3
4	Frequency command from RS485 communication is enabled

- ※ 1. It will be the maximum frequency (FMAX) when the knob is turned to MAX.
- ※ 2. It will be the maximum frequency (FMAX) when input with 10V.
- ※ 3. It will be the maximum frequency (FMAX) when input with 20mA.
- ※ 4. The multi-step speed command (setting value 1, 2, 3, 4) of multi-function input (n4.05-n4.08) will not be affected by the setting of n2.00 and will be enabled.
- ※ 5. Set n2.00=0 when using UP/DOWN command (setting value 10, 11) of the multi-function input (n4.05-n4.08). The input of operator increase/decrease key will become enabled. But meanwhile UP/DOWN command of the multi-function input has the priority.

## Chapter 5 Basic Operation

### ■ Selecting the secondary Frequency Command's Operation

The relation formula between frequency command and the secondary frequency command can be set. Only enabled when the secondary frequency command is used as adjustment frequency command.

n2.10	Selecting the Secondary Frequency Command Operation	Register No.	020A	Changes during operation	○
Setting range	0 ~ 2	Unit of setting	1	Default setting	0

- Set the relation formula between frequency command and the secondary frequency command.

#### 【Explanation of the setting values】

Setting value	Description
0	Disabled: actual frequency command = frequency command (n2.00)
1	Enabled: actual frequency command = frequency command (n2.00) + the secondary frequency command (n2.09)
2	Enabled: actual frequency command = frequency command (n2.00) - the secondary frequency command (n2.09)

### ■ The priority order of frequency command

Frequency command can be switched through the settings of “22 (the secondary frequency command)” , “1-3 (multi-step speed command)” .

The priority order is as below when multiple setting are made.

- ※ The setting values 10 and 11 (UP/DOWN command) are included in n2.00 (Selecting frequency command) or “22 (the secondary frequency command n2.09)” .

n2.00 (Selecting frequency command) < 22 (the secondary frequency command n2.09) < 1-3 (multi-step speed command)

### 5-4-2 Upper/Lower Limit of Frequency Command (n1.07, n1.08)

Regardless of the frequency command input method, the upper/lower limit of frequency command can be set.

If the frequency command that exceeds the upper/lower limit is received, the inverter will output upper/lower limit value only.

n1.07	Upper Limit of Frequency Command	Register No.	0107	Changes during operation	×
Setting range	0.1 ~ 120.0	Unit of setting	0.1%	Default setting	110.0
n1.08	Lower Limit of Frequency Command	Register No.	0108	Changes during operation	×
Setting range	0.0 ~ 100.0	Unit of setting	0.1%	Default setting	0.0

- The highest frequency of the upper/lower limit value for frequency command is 100%, set them in % respectively.

※ Be sure to set n1.08 ≤ n1.07

- ※ When the lower limit value (n1.08) of frequency command is less than minimum output frequency (n1.05), if the frequency command less than minimum output frequency is input, the inverter will not output it.

## 5-4-3 The Frequency Command by Using Digital Operator's Digital Setting ( n2.13 )

When n2.00 (Selecting frequency command) = 0 is set, the frequency command can be set through the increase/decrease key on digital operator.

■ The changes of frequency command

- When n2.00 (Selecting frequency command) = 0 is set, the frequency command can be set through the increase/decrease key on digital operator.
- Pressing the increase/decrease key on digital operator can change the setting value of frequency command.
  - Single press: changing in the minimum unit displaying on operator.
  - Continuous press: changing continuously in the minimum unit displaying on operator, one step forward every 5 seconds.
- Output frequency and the setting value of frequency command will change simultaneously with the preset speed.

■ Frequency command memory of digital operator

After the power is turned OFF, the frequency command set by the increase/decrease key on digital operator will be saved and display when power is connected next time.

n2.13	Operator/communication Frequency Command Memory selection	Register No.	020D	Changes during operation	×
Setting range	0 ~ 2	Unit of setting	1	Default setting	0

- After the power is turned OFF, the frequency command set by operator will be saved, and you can set whether to use it when power is connected next time.
- Set “0” or “1” to save the frequency command of operator. Not to save it, set “2” .

【Explanation of the setting values】

Setting value	Description
0	To save frequency command of operator/to save frequency command of communication
1	To save frequency command of operator/not to Save frequency command of communication
2	Not to save frequency command of operator/to Save frequency command of communication

※ When “not to save” is set, the frequency command will be counted from “0.00” after power is turned on.

## Chapter 5 Basic Operation

### 5-4-4 The Frequency Command (n5.00-n5.06) with Maximum Speed 7

Different from the setting of frequency command selection (n2.00), it can save multiple frequency commands inside the inverter to switch frequency commands input from control circuit. It is suitable for application of controlling inverter frequency by host device with only button switches and contact output.

#### ■ Setting multi-step speed frequency command

The multi-step speed with the maximum speed of 7 can be set. This frequency can be used via setting “1-3 (multi-step speed command)” in multi-function input (n4.05-n4.08).

n5.00	Frequency Command1	Register No.	0500	Changes during operation	○
Setting range	0.00 ~ 600.0	Unit of setting	0.01Hz	Default setting	0.00
n5.01	Frequency Command2	Register No.	0501	Changes during operation	○
Setting range	0.00 ~ 600.0	Unit of setting	0.01Hz	Default setting	0.00
n5.02	Frequency Command3	Register No.	0502	Changes during operation	○
Setting range	0.00 ~ 600.0	Unit of setting	0.01Hz	Default setting	0.00
n5.03	Frequency Command4	Register No.	0503	Changes during operation	○
Setting range	0.00 ~ 600.0	Unit of setting	0.01Hz	Default setting	0.00
n5.04	Frequency Command5	Register No.	0504	Changes during operation	○
Setting range	0.00 ~ 600.0	Unit of setting	0.01Hz	Default setting	0.00
n5.05	Frequency Command6	Register No.	0505	Changes during operation	○
Setting range	0.00 ~ 600.0	Unit of setting	0.01Hz	Default setting	0.00
n5.06	Frequency Command7	Register No.	0506	Changes during operation	○
Setting range	0.00 ~ 600.0	Unit of setting	0.01Hz	Default setting	0.00

- Set internal frequency command of multi-step speed command in Hz.

Frequency Command	Multi-step speed command 1 (setting value: 01)	Multi-step speed command 2 (setting value: 02)	Multi-step speed command 3 (setting value: 03)
Selecting Frequency Command (n2.00)	×	×	×
Frequency Command1	○	×	×
Frequency Command2	×	○	×
Frequency Command3	○	○	×
Frequency Command4	×	×	○
Frequency Command5	○	×	○
Frequency Command6	×	○	○
Frequency Command7	○	○	○

- ○ indicates input status (contact a is ON), × indicates non-input status (contact a is OFF). The multi-step speed commands not set in multi-function input are taken as OFF.

## 5-4-5 The Frequency Command by Using Analog Input (n2.06,n4.11~n4.18)

If n2.00 (Selecting frequency command) = 2 (frequency command input terminal A1, 0~10V) or 3 (frequency command input terminal A1, 4~20mA) is set, the frequency command can be input through analog input. The Default setting for analog input is as below; select it according to the output or analog signal features of the connected host device.

- Frequency command input terminal A1: voltage input 0 ~ +10V (0 to maximum frequency Hz)
  - ※ As analog signal is a kind of simple signal, its status can be confirmed by using measuring instrument. Usually for common use.
  - ※ As current input signal is less likely to be affected by electronic noise than voltage input signal, its disconnection can be detected.

## ■ Adjustment of analog input

Analog input can be adjusted according to the analog output specification of host device and output error. Perform the adjustment according to application.

n4.11	The minimum voltage input of frequency command input terminal A1	Register No.	040B	Changes during operation	×
Setting range	0.0 ~ 10.0	Unit of setting	0.1V	Default setting	0.0
n4.12	The minimum voltage command value of frequency command input terminal A1	Register No.	040C	Changes during operation	×
Setting range	0.0 ~ 100.0	Unit of setting	0.1%	Default setting	0.0
n4.13	The maximum voltage input of frequency command input terminal A1	Register No.	040D	Changes during operation	×
Setting range	0.0 ~ 10.0	Unit of setting	0.1V	Default setting	10.0
n4.14	The maximum voltage command value of frequency command input terminal A1	Register No.	040E	Changes during operation	×
Setting range	0.0 ~ 100.0	Unit of setting	0.1%	Default setting	100.0
n4.15	The minimum current input of multi-function analog input terminal A1	Register No.	040F	Changes during operation	×
Setting range	0.0 ~ 20.0	Unit of setting	0.1mA	Default setting	4.0
n4.16	The minimum current command value of multi-function analog input terminal A1	Register No.	0410	Changes during operation	×
Setting range	0.0 ~ 100.0	Unit of setting	0.1%	Default setting	0.0
n4.17	The maximum current input of multi-function analog input terminal A1	Register No.	0411	Changes during operation	×
Setting range	0.0 ~ 20.0	Unit of setting	0.1mA	Default setting	20.0
n4.18	The maximum current command value of multi-function analog input terminal A1	Register No.	0412	Changes during operation	×
Setting range	0.0 ~ 100.0	Unit of setting	0.1%	Default setting	100.0

- To adjust the input characteristic by setting the points of analog input minimum value and maximum value. Set the input characteristic referring to the diagram below.

※ Do not same as the adjust method of the Frequency Command.

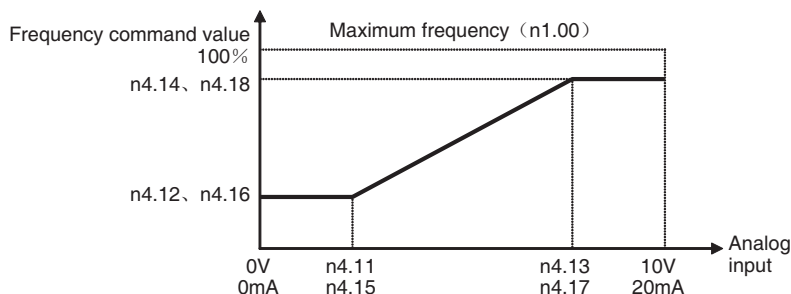

## Chapter 5 Basic Operation

---

### ■ Loss detection of multi-function analog input terminal A1

When using the Default setting (current input) for multi-function analog input, the analog input loss caused by signal disconnection and so on can be detected. The safety of device hereby will be improved effectively.

n2.06	Selecting Loss Detection for Multi-function Analog Input (terminal A1)	Register No.	0206	Changes during operation	×
Setting range	0 ~ 2	Unit of setting	1	Default setting	0

- Enabled when using current input for multi-function analog input. Set whether to detect loss of multi-function analog input and stop method after detection.
- When the current input value for multi-function analog input is less than the setting value of n4.15 (the minimum current input of multi-function analog input terminal A1), it will be taken as a loss, and error of multi-function analog input signal will be detected.
- When the error of multi-function analog input signal is detected, the “AErr” will display on operator. After clearing the cause of the error, cancel the alarm by using the RESET key on operator or by inputting error reset for multi-function input.

#### 【Explanation of the setting values】

Setting value	Description
0	Loss detection disabled: decelerate to 0Hz (operate according to frequency command)
1	The error of multi-function analog input signal ( “AErr” ) is detected: coast to “stop” after detection
2	Error detected, without displaying “AErr” , operate according to the frequency used before disconnection.

※ When n4.15 (the minimum current input of multi-function analog input terminal A1) = 0 is set or the voltage input is switched, loss detection will be disabled.

### 5-4-6 The Frequency Command by Using UP/DOWN Command

Under the situation of n2.00 (Selecting frequency command) = 0, if UP/DOWN command (setting values 10, 11) is set in multi-function input (n4.05-n4.08), the frequency command (UP/DOWN) can be operated from control circuit terminal. Use this if you want to use external switch to adjust frequency command up and down.

#### ■ Setting UP/DOWN command

- Set the values of “10 (UP command)” and “11 (DOWN command)” in multi-function input (n4.05-n4.08).
- Set n2.00 (selecting frequency command) = 0 or n2.09 (selecting the secondary frequency command) = 0. The UP/DOWN command is enabled only if the frequency command is set to “0”.
- ※ 2.00 and n2.09 can be set to “0” simultaneously, the input method can not be changed even if frequency command and the secondary frequency command are switched.
- When the UP/DOWN command is set, the increase/decrease key of operator is still enabled. If they are input at the same time, UP/DOWN command has the priority.

#### 【Operation of UP/DOWN function】

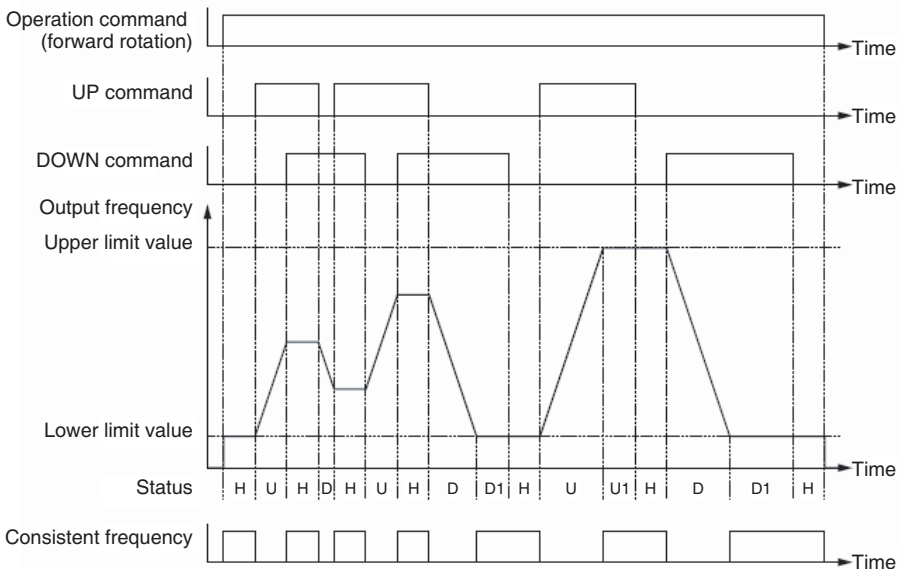

※Status description

- U: UP (acceleration) status
- D: DOWN (deceleration) status
- H: HOLD status
- U1: UP status with upper limit value restricted
- D1: DOWN status with lower limit value restricted

## Chapter 5 Basic Operation

### 5-4-7 The Frequency Command from Communication (n2.13)

If n2.00 (selecting frequency command) = 4 (frequency command from communication) is set, the frequency command from communication will be enabled.

The related command of communication method for RS485 communication installed in this inverter is in [Chapter 7 Communication], refer to it following [Chapter 5 Basic Operation].

#### ■ Frequency command memory of communication

After power is turned off, the frequency command from communication can be saved and will display when power is connected next time.

n2.13	Operator/Communication Frequency Command Memory Selection	Register No.	020D	Changes during operation	×
Setting range	0 ~ 2	Unit of setting	1	Default setting	0

• After the power is turned OFF, the frequency from communication will be saved, and you can set whether to use it when power is connected next time.

• Set “0” or “2” to save the frequency command of communication. Not to save it, set “1” .

#### 【Explanation of the setting values】

Setting value	Description
0	To save frequency command of operator/to save frequency command of communication
1	To save frequency command of operator/not to Save frequency command of communication
2	Not to save frequency command of operator/to Save frequency command of communication

※ When “not to save” is set, the frequency command will be counted from “0.00” after power is turned on.

## 5-5 Setting Acceleration/Deceleration Time

Acceleration/Deceleration status can be set in the output frequency of inverter. This chapter explains the parameter. Generally, there are 3 modes for Acceleration/Deceleration. Set it according to application.

- Trapezoidal Acceleration/Deceleration: the method used universally.
- S-shape Acceleration/Deceleration: select it when the impact from starting and stopping needs to be lessened.

### 5-5-1 Setting Acceleration/Deceleration Time(n1.09~n1.12)

To set the trapezoidal ACCELERATION/DECELERATION mode through Acceleration/Deceleration time.

#### ■ Setting Acceleration/Deceleration time

Set the Acceleration/Deceleration time for common frequency command.

By using the “7 (switching of Acceleration/Deceleration time)” set in multi-function input (n4.05-n4.08), you can switch between Acceleration/Deceleration time 1 and Acceleration/Deceleration time 2.

n1.09	Acceleration Time 1	Register No.	0109	Changes during operation	○
Setting range	0.1 ~ 600.0	Unit of setting	0.1s	Default setting	10.0
n1.10	Deceleration Time 1	Register No.	010A	Changes during operation	○
Setting range	0.1 ~ 600.0	Unit of setting	0.1s	Default setting	10.0
n1.11	Acceleration Time 2	Register No.	010B	Changes during operation	○
Setting range	0.1 ~ 600.0	Unit of setting	0.1s	Default setting	10.0
n1.12	Deceleration Time 2	Register No.	010C	Changes during operation	○
Setting range	0.1 ~ 600.0	Unit of setting	0.1s	Default setting	10.0

- To set acceleration time according to the time taking from 0% to 100% of maximum frequency, and set deceleration time according to the time taking from 100% to 0% of maximum frequency.
- The formula for actual Acceleration/Deceleration time is as below.

$$\text{Acceleration/Deceleration time} = (\text{setting Acceleration/Deceleration time}) \times (\text{frequency command}) / (\text{maximum frequency})$$

- Setting “7” in multi-function input (n4.05-n4.08) to switch between Acceleration/Deceleration time 1 and Acceleration/Deceleration time 2.  
Under input status, switch to Acceleration/Deceleration time 2.

## Chapter 5 Basic Operation

---

### 5-5-2 Setting S-shape Acceleration/Deceleration Characteristic (n1.17、 n1.18)

The S-shape characteristic that can lessen the impact caused by starting and stopping can be set in Acceleration/Deceleration time that has already been set.

n1.17	S-shape Characteristic Time under Acceleration	Register No.	0111	Changes during operation	×
Setting range	0.0 ~ 10.0	Unit of setting	0.1s	Default setting	0.0
n1.18	S-shape Characteristic Time under deceleration	Register No.	0112	Changes during operation	×
Setting range	0.0 ~ 10.0	Unit of setting	0.1s	Default setting	0.0

- To set S-shape characteristic time (as addition) in the set Acceleration/Deceleration time (n1.09-n1.12).
- The actual Acceleration/Deceleration time will be the sum of setting value for Acceleration/Deceleration time or jog Acceleration/Deceleration time and setting value for S-shape characteristic time.

※ “0.0 ” set in S-shape characteristic time is disabled.

## 5-6 Selecting the Reverse Rotation-Prohibit

When inputting reverse direction command, reversing motor and reverse prohibition can be selected. In the application not suitable for reverse rotation, set reverse prohibition.

### ■ Selecting the reverse rotation-prohibit

n2.04	Reverse Rotation-prohibit Selection	Register No.	0204	Changes during operation	×
Setting range	0 ~ 2	Unit of setting	1	Default setting	0

- Set whether to prohibit reverse rotation (or forward rotation) for inverter.

### 【Explanation of the setting values】

Setting value	Description
0	Reverse allowed (forward allowed)
1	Reverse prohibited (forward allowed)
2	Reverse allowed (forward prohibited)

※ When reverse or forward is prohibited, the prohibited direction command will become reverse direction command.

## 5-7 Selecting the Stopping Mode

This parameter is used to specify the stopping mode when stop command is input or external error occurs. The Inverter either decelerates or coasts to a stop according to the stopping mode selection.

### ■ Selecting the Stopping Mode

n2.02	Stopping Mode Selection	Register No.	0202	Changes during operation	×
Setting range	0 ~ 3	Unit of setting	1	Default setting	0

- Set the stopping mode when stop command is input or external error occurs.
- Set “14 (external error input)” in multi-function input (n4.05-n4.08) to input external error.

### 【Explanation of the setting values】

Setting value	Description
0	Stop command is to decelerate to stop/external error is to coast to stop
1	Stop command is to coast to stop/ external error is to coast to stop
2	Stop command is to decelerate to stop/external error is to decelerate to stop
3	Stop command is to coast to stop/ external error is to decelerate to stop

- ※ 1.The Inverter will decelerate to stop according to deceleration time (n1.10, n1.12)
- ※ 2.If the RUN signal is input again during a deceleration stop, deceleration will be stopped at the point of the input and acceleration will proceed at that frequency.
- ※ 3.Do not input a RUN signal during a free-running stop if the motor's rotation speed is not sufficiently slowed. If a RUN signal is input under these conditions, a main circuit overvoltage (OV) or overcurrent (OC) will be detected.

## 5-8 Multi-function I/O

### 5-8-1 Setting Multi-function Input (n4.05 ~ n4.08)

SYSDRIVE 3G3JZ incorporates four multi-function input terminals (S3 ~ S6).

Inputs into these terminals have a variety of functions according to the application.

n4.05	Selecting Multi-function Input 3 (input terminal S3)	Register No.	0405	Changes during operation	×
Setting range	0 ~ 22	Unit of setting	1	Default setting	14
n4.06	Selecting Multi-function Input 4 (input terminal S4)	Register No.	0406	Changes during operation	×
Setting range	0 ~ 22	Unit of setting	1	Default setting	5
n4.07	Selecting Multi-function Input 5 (input terminal S5)	Register No.	0407	Changes during operation	×
Setting range	0 ~ 22	Unit of setting	1	Default setting	1
n4.08	Selecting Multi-function Input 6 (input terminal S6)	Register No.	0408	Changes during operation	×
Setting range	0 ~ 22	Unit of setting	1	Default setting	2

- Set the input functions according to the application.

#### 【Explanation of the setting values】

Setting value	Function name	Description															
0	Multi-function input disabled	Set it when multi-function input is not used.															
1	Multi-step speed command 1 ※ 1	Signal to switch frequency command 1-7 (n5.00-n5.06) ※ For details, refer to [5-5-5 The Frequency Command (n5.00-n5.06)].															
2	Multi-step speed command 2 ※ 1																
3	Multi-step speed command 3 ※ 1																
5	Error reset	ON: error reset (disabled in operation command input)															
7	Acceleration/ Deceleration time switching	ON: Acceleration/Deceleration time 2 (n1.11, n1.12)															
9	Command for blocking external base electrode	ON: output cut															
10	UP command ※ 1 (UP/DOWN command)	Function of UP/DOWN command for increasing or decreasing frequency command. Be sure to set UP command and DOWN command simultaneously.															
11	DOWN command ※ 1 (UP/DOWN command)	<table border="1"> <thead> <tr> <th>Status</th> <th>ACC</th> <th>DEC</th> <th>Hold</th> <th>Hold</th> </tr> </thead> <tbody> <tr> <td>UP command</td> <td>ON</td> <td>OFF</td> <td>OFF</td> <td>ON</td> </tr> <tr> <td>DOWN command</td> <td>OFF</td> <td>ON</td> <td>OFF</td> <td>ON</td> </tr> </tbody> </table>	Status	ACC	DEC	Hold	Hold	UP command	ON	OFF	OFF	ON	DOWN command	OFF	ON	OFF	ON
		Status	ACC	DEC	Hold	Hold											
		UP command	ON	OFF	OFF	ON											
DOWN command	OFF	ON	OFF	ON													
※ After multi-step speed commands 1-3 are input, the multi-step speed commands have the priority.																	
※ In order to save frequency command of UP/DOWN command after power is OFF, set “0” or “1” in constant of n2.13.																	

Setting value	Function name	Description
14	External error	ON: external error (EF error detection)
16	Coast to stop	ON: output is cut, and the inverter coasts to stop ※ After input is cancelled, the device will restart from 0Hz
17	Prohibit to change parameters	ON: prohibit to change parameters
18	Operation command switching (control circuit terminal) ※ 2	ON: the operation command from control circuit terminal is enabled OFF: setting of operation command selection (n2.01) is enabled
19	Operation command switching (operation panel) ※ 2	ON: RUN/STOP key on operation panel is enabled OFF: setting of operation command selection (n2.01) is enabled
20	Operation command switching (communication) ※ 2	ON: operation command from communication is enabled OFF: setting of operation command selection (n2.01) is enabled
22	The secondary frequency command ※ 1	ON: the secondary frequency command (n2.09) is enabled

- ※ 1. Priority is as below, with the highest priority for jog command. And UP/DOWN command (setting values 10, 11) is included in n2.00 (Selecting frequency command) or “22 (the secondary frequency command n2.09)” .  
n2.00 (Selecting frequency command) < 22 (the secondary frequency command n2.09) < 1-3 (multi-step speed command)
- ※ 2. Priority is as below, with the highest priority for operation command switch: control circuit terminals.  
n2.01 (Selecting operation command) < 20 (operation command switch: communication) < 19 (operation command switch: operator) < 18 (operation command switch: control circuit terminals)

### 5-8-2 Setting Multi-function Output (n3.00, n3.02)

SYSDRIVE 3G3JZ, there are 2 points for multi-function output, contact output (output terminal MA/MB-MC) and photo coupler output (output terminal PI-PC). The output can be used for various multi-function settings according to application.

n3.00	Selecting Multi-function Output 1 (output terminal MA/MB-MC)	Register No.	0300	Changes during operation	×
Setting range	0 ~ 21	Unit of setting	1	Default setting	8

- Set the output function according to the application.

#### 【Explanation of the setting values】

Setting value	Function name	Description
0	Multi-function output disabled	Set it when Multi-function output is unused.
1	Operating	ON: operating (operation inputting/inverter outputting) ※ Under DC brake or base electrode block the status is also ON.
2	Consistent frequency	ON: frequency is consistent (with frequency command) ※ The status is ON when frequency is within frequency command $\pm$ 2Hz, and OFF when exceeds frequency command $\pm$ 4Hz.
3	Zero speed 1	ON: zero speed (less than minimum output frequency) ※ When operation command is OFF, if not output, the status will become OFF.

## Chapter 5 Basic Operation

Setting value	Function name	Description
4	Overtorque detection	ON: output when the following constant conditions are met. <ul style="list-style-type: none"> <li>• Selecting overtorque detection (n6.03)</li> <li>• Overtorque detection level (n6.04)</li> <li>• Overtorque detection time (n6.05)</li> </ul>
5	Base electrode block	ON: blocking base electrode (inputting the base electrode block command)
6	Low voltage detection	ON: detecting low voltage (when low voltage UV error of main circuit is detected) ※ When DC voltage of main circuit is 200 VAC, it will detect at 198VDC, when 400VAC, it will detect at 396VDC.
7	Operation command output	ON: control circuit terminal/OFF: other than control circuit terminal
8	Error output	ON: error output
9	Frequency detection	ON: output frequency $\geq$ frequency detection level (n3.02)
12	Stall prevention during deceleration	ON: Stall prevention during deceleration (n6.00)
13	Stall prevention during acceleration/operation	ON: Stall prevention during acceleration/operation (n6.01/n6.02)
14	Overheating of inverter	ON: inverter is overheating (the temperature of fin is over 85 °C )
15	Overvoltage	ON: overvoltage (voltage of main circuit exceeds the predicted voltage) ※ When DC voltage of main circuit is 200 VAC, it will predict at 374VDC, when 400VAC, it will predict at 747VDC.
17	Forward rotation	ON: forward rotating ※ Input operation command for forward rotation direction, and it will keep ON before reverse rotation direction command is input.
18	Reverse rotation	ON: reverse rotating ※ Input operation command for reverse rotation direction, and it will keep ON before forward rotation direction command is input.
19	Zero speed 2	ON: zero speed (less than minimum output frequency) ※ Continue to output even when operation command is OFF.
20	Warning output	ON: warning output
21	External stopper output	ON: open external stopper ※ Set control time according to open frequency (n3.11) and operation frequency (N3.12) of external stopper

● Operating/consistent frequency/zero speed 1/frequency detection/zero speed 2

The figure below explains the output time for operating/consistent frequency/zero speed 1/frequency detection/zero speed 2 of multi-function output.

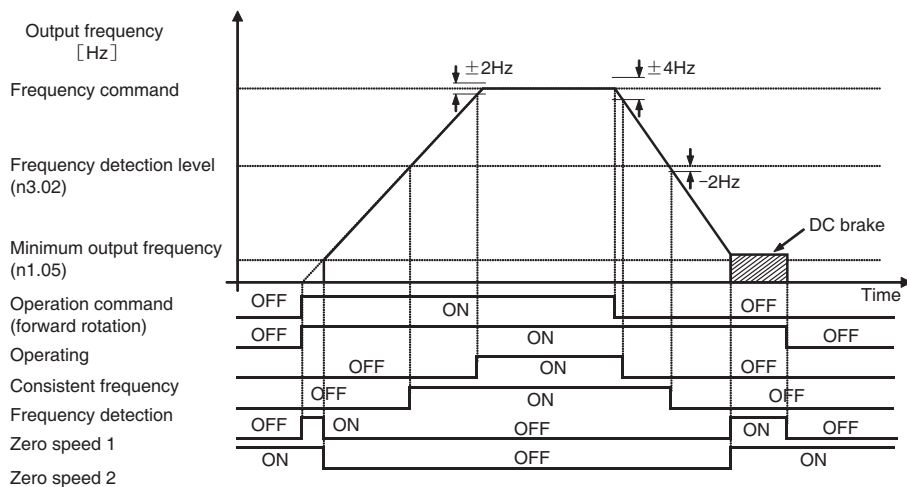

### 5-8-3 Detection Level of Frequency Detection (n3.02)

The function will be used to output signals when the output frequency of inverter exceeds the set frequency.

Enabled when rpm of motor and timing of peripheral device need to be selected.

n3.02	Frequency Detection Level	Register No.	0302	Changes during operation	×
Setting range	0.00 ~ 600.0	Unit of setting	0.01Hz	Default setting	0.00

- Set the frequency to be detected.
- In multi-function output (n3.00), set “9 (frequency detection)” to output.

### 5-9 Multi-function Analog Output

SYSDRIVE 3G3JZ incorporates multi-function analog output terminals (AM-AC).

The analog output is a PWM wave which the carrier frequency is 1KHz ,it could connect to analog input directly.

#### ■ Selecting multi-function analog output

n3.03	Selecting Multi-function Analog Output	Register No.	0303	Changes during operation	○
Setting range	0, 1	Unit of setting	1	Default setting	0

- Set the monitored items that need to be output in multi-function analog output.

#### 【Explanation of the setting values】

Setting value	Description
0	Frequency of monitoring output: 0-10V/0-maximum frequency (n1.00)
1	Current of monitoring output: 0-10V/0-250% of the inverter rated output current

#### ■ Gain adjustment of multi-function analog output

n3.04	Multi-function Analog Output Gain (output terminal AM-AC)	Register No.	0304	Changes during operation	○
Setting range	0 ~ 200	Unit of setting	1%	Default setting	100

- Set the adjustment rate in multi-function analog output voltage. Set the gain of multi-function analog output in the unit of %.
- When 50% is set.
  - Frequency of monitoring output: 0-5V/0-maximum frequency (n1.00)
  - Current of monitoring output: 0-5V/0-250% of the inverter rated output current

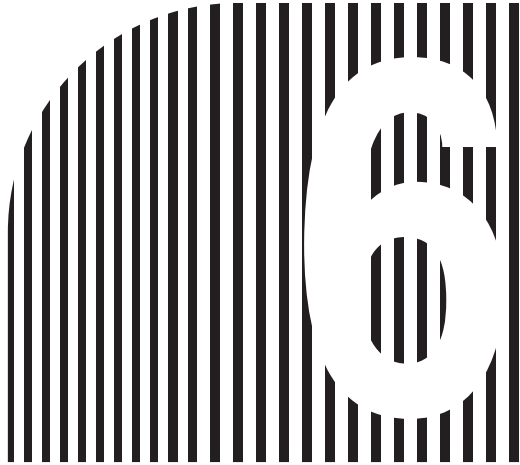

## Chapter 6

### ● Advanced Operation ●

- 6-1 Slip Compensation Function
- 6-2 Torque Compensation Function
- 6-3 Setting the Carrier Frequency
- 6-4 Energy Saving Control
- 6-5 Input Terminal Setting Function
- 6-6 External Stopper Operation Time Function
- 6-7 Overtorque Detection Function
- 6-8 DC Injection Braking Function
- 6-9 Stall Prevention Function
- 6-10 Other Functions

# Chapter 6 Advanced Operation

---

This chapter provides information on the use of advanced functions of the inverter for operation.

Refer to this chapter to use the various advanced functions, such as slip compensation function, torque compensation function, carrier frequency setting, energy saving control, internal input setting function of input terminal, operation timing function of external stopper, overtorque detection function, DC brake function, stall prevention function.

---

## 6-1 Slip Compensation Function

---

The slip compensation function calculates the motor slip value according to the output current of inverter in order to compensate output frequency.

This function is used to improve speed accuracy when operating with a load. As an auxiliary function for Sensorless Vector Control, it can be used in combination with Sensorless Vector Control to further improve speed accuracy and output torque.

---

### ■ Setting motor constant

To perform slip compensation function, motor constant must to be set.

Set the basic motor rated current (n7.00) and the motor no-load current (n7.01) firstly. If n7.00 = 0.0, the slip compensation function will be disabled.

Please setting Slip Compensation Gain Base on Rated Motor Slip, the more Rated Motor Slip is, the more Slip Compensation Gain is.

### ■ Adjustment of slip compensation

After motor constant is set, slip compensation function is ready. In order to enable the function, n7.03 (slip compensation gain) = 1 must be set. confirm the operation of application as adjusting the following functions.

n7.03	Slip Compensation Gain	Register No.	0703	Changes during operation	○
Setting range	0.00 ~ 10.00	Unit of setting	0.01	Default setting	0.00

- Set the gain of slip compensation function. To disable slip compensation, the default setting will be "0". Set it to "1" to enable slip compensation function.
  - Confirm the applied operation. When motor speed decreases with a heavy load, increase the setting value to adjust.
  - On the contrary, when motor speed increases with a load, decrease the setting value to adjust.
  - Operation will be different according to operation frequency. When operation overextends, adjust is to middle frequency or the most important frequency.
- ※ If n7.03 = 0.0, the slip compensation function will be disabled.

## 6-2 Torque Compensation Function

This function increases the output torque by detecting an increase in the motor load under the case of one inverter connected one motor.

Enabled especially used under V/f control mode.

If one inverter is connected to multiple motors, the torque compensation function cannot normally operate but increase output current, therefore, disable the function.

<b>n7.02</b>	Torque Compensation Gain	Register No.	0702	Changes during operation	○
Setting range	0.0 ~ 10.0	Unit of setting	0.1	Default setting	1.0

- Set the gain for torque compensation function. The default setting does not need any changes in normal operation.
  - If the output torque under low speed operation is insufficient, increase setting value. Output current will increase with the increment of setting value, check whether the output current value of operation is 100%-150% of motor rated current, and whether overload of motor is detected.
  - If one inverter is connected to multiple motors, set n7.02 = 0 to disable torque compensation function.
- ※ If n7.02 = 0.0, the torque compensation function will be disabled.

**6-3 Setting the Carrier Frequency**

The setting of output carrier frequency for inverter can be changed.

The default setting does not need any changes in normal operation; however, the carrier frequency should be adjusted under the following cases.

- Need to reduce the noise from motor
- Need to reduce the disturbance from noise of inverter
- The cable between inverter and motor is too long

n2.03	Carrier Frequency Selection	Register No.	0203	Changes during operation	×
Setting range	2 ~ 15	Unit of setting	1kHz	Default setting	8

- Set carrier frequency of inverter, the default setting does not need any changes in normal operation.
- To lower the sound from motor, increase the setting of carrier frequency. The frequency of sound audible for human is less than about 11kHz normally, if the set frequency is higher than this one, we will not able to hear the sound.
- If the electronic noise leaking from inverter harms the machines around, set a smaller value.  
If the machines around are still influenced when the setting is less than 2kHz, consider the use of noise reducing equipments such noise filter to solve the problem.
- If the cable between inverter and motor is too long, set the carrier frequency with the following values as criteria.

Length of the cable between inverter and motor	Shorter than 50m	Shorter than 100m	Longer than 100m
Setting of carrier frequency	Less than 10kHz	Less than 5kHz	Less than 2kHz

※ When the setting value of carrier frequency is more than 8kHz, the rated output current of inverter will be decreased due to the increased heat inside inverter.

The relation between carrier frequency and inverter rated current is shown as below. Based on the value of inverter rated output current as 100%, indicate the different values in %.

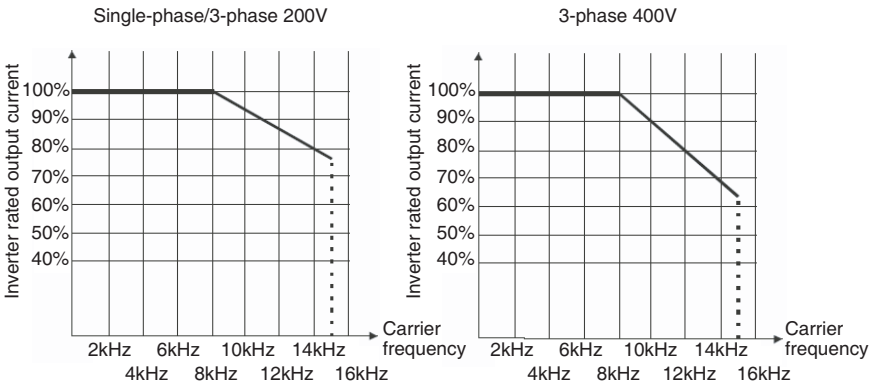

## 6-4 Energy Saving Control

The energy saving control function automatically saves unnecessary power that is uselessly consumed while the load is light.

To automatically adjust the motor power status to the status suitable for the load.

The function is applicable for the case when the load is light for a long time and changes little.

n8.17	Energy Saving Control Selection	Register No.	0811	Changes during operation	×
Setting range	0, 1	Unit of setting	1	Default setting	0

- Set whether to enable energy saving control.
- Under the case that the torque changes frequently, high torque or vector control is required; disable it because of the low effect. Otherwise, the torque output performance will be reduced.

### 【Explanation of the setting values】

Setting value	Description
0	Disabled
1	Enabled

※ After the energy saving control is enabled, the output voltage will be reduced to 70% of maximum output voltage in V/f mode.

## 6-5 Input Terminal Setting Function

The following simple input setting function is equipped in 3G3JZ series.

Internal input setting function: without external wiring, the status of input terminal can be operated by setting parameter constants.

By setting parameter constants, switching function of a contact/b contact can set a contact/b contact of any input terminal.

The setting method will be explained below.

### 6-5-1 Internal Input Setting Function of Input Terminal (n4.27, n4.28)

Using this function, the status of input terminal can be operated by setting parameter constants, without external wiring.

When using a single inverter, this function is quite useful for the case that the operation needs to be started the moment power is turned ON, or the operation of device needs to be confirmed.

n4.27	Internal Input Selection for Input Terminal	Register No.	041B	Changes during operation	×
Setting range	0 ~ 63	Unit of setting	1	Default setting	0
n4.28	Status Selection for Internal Input	Register No.	041C	Changes during operation	0
Setting range	0 ~ 63	Unit of setting	1	Default setting	0

- Set the input terminal for internal input in n4.27.
- Set the input status for internal input terminal in n4.28.
- The setting methods will be explained as below:
  - ① Set the input terminal of inverter in every digit under binary.
  - ② In every digit, in order to set the terminal which is to be set as internal input to "1", or to turn ON the terminal which is set as internal input, set "1".
  - ③ Switch the binary set in ② to decimal whose values will be set in constant.

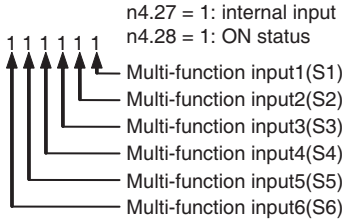

**【Example of setting values】**

Set multi-function input 1, 2, 4 as internal input, and set ON in the internal input of multi-function input 1, 2, 4.

The set binary: 001011

Switch binary to decimal:  $2^3 \times 1 + 2^1 \times 1 + 2^0 \times 1 = 11$

- n4.27 = 11 setting → multi-function input 1, 2, 4 set as internal input
- n4.28 = 11 setting → multi-function input 1, 2, 4 set as input fixing status (a contact ON)

**6-5-2 Multi-function Input Terminal Contact Status Setting (n4.09)**

By setting parameters, a contact (always open)/b contact (always closed) of any input terminal can be set.

Set it according to applications and output of host device.

n4.09	Input Selection of a contact/b contact for Multi-function Input	Register No.	0409	Changes during operation	×
Setting range	0 ~ 63	Unit of setting	1	Default setting	0

- Set the input terminal which is to be b contact input (always closed).
- Setting methods are explained as below:
  - ① Set the input terminal of inverter in every digit under binary.
  - ② In every digit, set the input terminal which is to be set as b contact input (always closed) to "1".
  - ③ Switch the binary set in ② to decimal whose values will be set in constant.

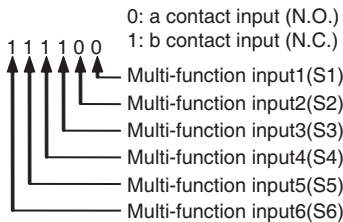

**【Example of setting values】**

When setting multi-function input 4, 5 as b contact input.

The set binary: 0011000

Switch binary to decimal:  $2^4 \times 1 + 2^3 \times 1 = 24$

- n4.09=24 setting → multi-function input 4, 5 set as b contact input.
- S1-S2 couldn't be set as b contact input when using 2-wire sequence connections (n4.04=0, 1).
- S1-S3 couldn't be set as b contact input when using 3-wire sequence connections (n4.04=2).

### 6-5-3 Input Terminal Responding Time (n4.10)

The responding time of input terminal can be changed by the function. Enabled to reduce the influence from vibration of delay and electronic noise.

However, if the responding time is set too long, the operation of inverter itself will be slowed.

n4.10	Input Terminal Responding Time	Register No.	040A	Changes during operation	×
Setting range	1 ~ 20	Unit of setting	1(2ms)	Default setting	1

- Set the responding time of input terminal. The default setting does not need any changes in normal operation.
- In order to reduce the fault operations caused by vibration of delay and electronic noise, set the responding time a little bit longer. Setting value 1 is equivalent to time of 2ms.

## 6-6 External Stopper Operation Time Function

External stopper is set in vertical axis to keep load from falling. The function of outputting output frequency and external stopper operation time is equipped in 3G3JZ series. The setting will be explained below.

n3.11	Released Frequency of External Stopper	Register No.	030B	Changes during operation	×
Setting range	0.00 ~ 20.00	Unit of setting	0.01Hz	Default setting	0.00
n3.12	Operation Frequency of External Stopper	Register No.	030C	Changes during operation	×
Setting range	0.00 ~ 20.00	Unit of setting	0.01Hz	Default setting	0.00

- This function can be used to set the signals controlling external stopper operation time. Set the time of external stopper release and operation in inverter output frequency.
- Set the released frequency and operation frequency of external stopper in n3.11 and n3.12 respectively in Hz.
- ※ Set "21 (external stopper output)" in multi-function output (n3.00) to connect external stopper.
- ※ In order to keep the load from falling, set the stopper operation status and inverter output status to the form of multi-Hz repeating in vertical axis.

Furthermore, be sure to confirm the operation after setting.

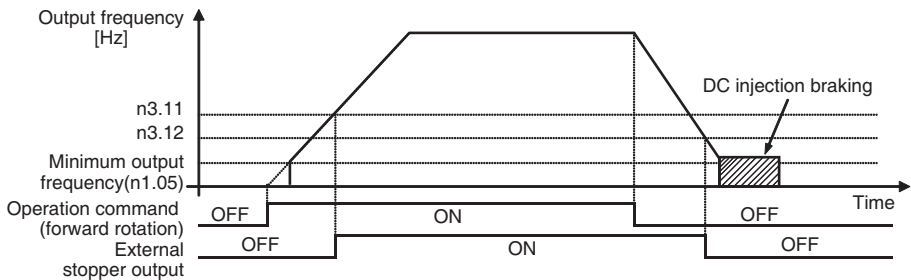

6-7 Over Torque Detection Function

The function can detect whether an excessive load is applied to the equipment according to the increase of output current (or output torque). Enabled when protecting equipment from damage or detecting load error.

n6.03	Over Torque Detection Function Selection	Register No.	0603	Changes during operation	×
Setting range	0 ~ 4	Unit of setting	1	Default setting	0

- Set enabled/disabled, detection status and post detection disposal for overtorque detection function.
- The status of exceeding overtorque detection level (n6.04) will be detected when the status keeps for a period of time after overtorque detection time (n6.05) elapsed.
- After overtorque is detected, "OL2" will display for error detection, "AOL2" for warning detection.
- ※ When resetting after error detection, input the reset input.
- For warning detection, it will be cancelled automatically if the output current detection level is increased.
- ※ If "04(detecting overtorque)" is set in multi-function output (n3.00), it can be output to outside.

【Explanation of the setting values】

Setting value	Description
0	Over torque detection disabled
1	Detect only when speed is consistent/continue to operate after detection (warning detection)
2	Detect only when speed is consistent/cut the output during detection (error detection)
3	Detect often during operation/ continue to operate after detection (warning detection)
4	Detect often during operation/ cut the output during detection (error detection)

n6.04	Overtorque Detection Value	Register No.	0604	Changes during operation	0
Setting range	10 ~ 200	Unit of setting	1%	Default setting	150

- Set the percentage of detection level for overtorque detection function based on inverter rated output current as 100%.

n6.05	Overtorque Detection Time	Register No.	0605	Changes during operation	×
Setting range	0.1 ~ 60.0	Unit of setting	0.1s	Default setting	0.1

- Set the detection time of overtorque detection function in s.

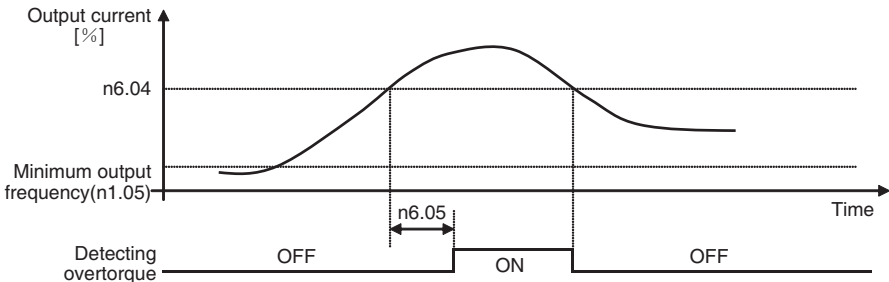

**6-8 DC Injection Braking Function**

The DC injection braking function applies DC voltage on the induction motor for braking motor.

- DC injection braking during startup:  
Enabled to stop the motor rotating by inertia (no regenerative processing) and start it again.
- DC injection braking during stop:  
Make adjustments if the motor rotating does not decelerate to a stop in normal operation due to inertia from a heavy load.  
By increasing the DC injection braking time or DC injection braking current, the time required for stopping the motor is reduced.

<b>n8.00</b>	DC Injection Braking Current	Register No.	0800	Changes during	×
Setting range	0 ~ 100	Unit of setting	1	Default setting	50
<b>n8.01</b>	DC Injection Braking Time during Startup	Register No.	0801	Changes during operation	×
Setting range	0.0 ~ 60.0	Unit of setting	0.1s	Default setting	0.0
<b>n8.02</b>	DC Injection Braking Time during Stop	Register No.	0802	Changes during operation	×
Setting range	0.0 ~ 60.0	Unit of setting	0.1s	Default setting	0.5
<b>n8.03</b>	DC Injection Braking Start Frequency during Stop	Register No.	0803	Changes during operation	×
Setting range	0.00 ~ 600.0	Unit of setting	0.01Hz	Default setting	0.00

- Set the % of DC injection braking current based on inverter rated current as 100%.
- Set the DC injection braking time during startup in s. After DC injection braking time during startup, the device will start from minimum frequency (n1.05).
- Set the DC injection braking start frequency during stop in Hz, and DC injection braking time during stop in s. Regardless of the minimum output frequency, the DC injection braking function will start operation from the frequency set in n8.03.

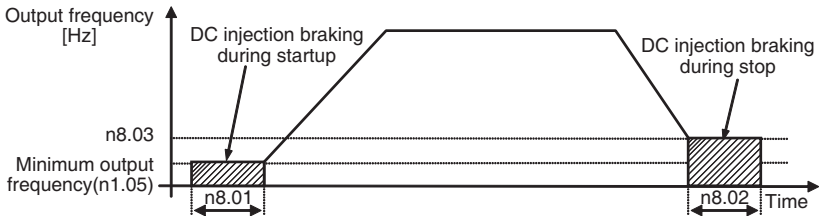

**6-9 Stall Prevention Function**

A stall will occur if the motor cannot keep up with the rotating magnetic field on the motor stator side when a large load is applied to the motor or a sudden acceleration/deceleration is performed.

Also called [Motor Stall], [Motor Maladjustment].

In SYSDRIVE 3G3JZ, stall prevention function can be set independently for accelerating/operating/ decelerating condition.

n6.00	Stall Prevention Level during Deceleration	Register No.	0600	Changes during operation	×
Setting range	0.0, 330.0 ~ 410.0(0.0, 660.0 ~ 820.0)	Unit of setting	0.1V	Default setting	390.0 (780.0)

- Set the value of main circuit DC voltage what makes the stall prevention function during deceleration operate in V. The default setting does not need any changes in normal operation.
- When main circuit DC voltage reached the set value during deceleration, the deceleration will stop automatically to avoid overvoltage (OV) and start again after the main circuit DC voltage is lowered. After the operation of stall prevention during deceleration, the actual deceleration time is longer than the set time.
- Under the status of default setting, if overvoltage (OV) occurs during deceleration, decrease setting value in 5V, then confirm the operation.
- ※ If the stall prevention level during deceleration is set too low, deceleration time will be very long. Be sure to confirm the operation when changing setting values. If power is of 3-phase 400VAC, the main circuit DC voltage will be about 566VDC ( $400 \times \sqrt{2}$ ). Set the voltage that is over 100VDC higher than power voltage (being inverted into DC value).
- ※ The values in the parentheses are setting range and Default settings of 400VAC inverter.
- ※ If n6.00 = 0 is set, stall prevention function during deceleration will be disabled.

**【Stall prevention during deceleration】**

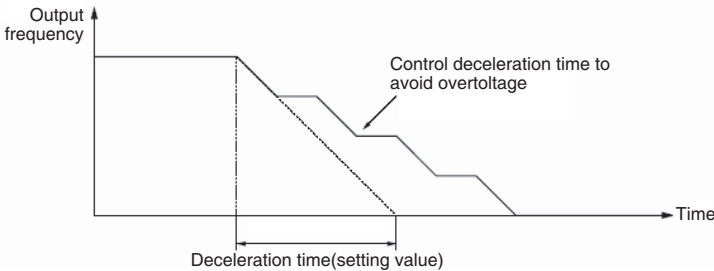

n6.01	Stall Prevention Level during Acceleration	Register No.	0601	Changes during operation	×
Setting range	0, 20 ~ 250	Unit of setting	1%	Default setting	170

- When output current exceeds the set current value, the acceleration will stop to avoid stalling during acceleration and start again when the output current is less than the setting value.
- Set the percentage of stall prevention level during acceleration based on the inverter rated output current as 100%.
- The default setting does not need any changes in normal operation. Decrease the setting value if the capacity of the motor is smaller than that of the Inverter or the motor stalls with the default value.
- The setting value is normally 2 times as the rated current of the motor. Set the percentage of this current based on the inverter rated current as 100%.
- ※ After n6.01 = 0 is set, stall prevention function during acceleration will be disabled.

### 【Stall prevention function during acceleration】

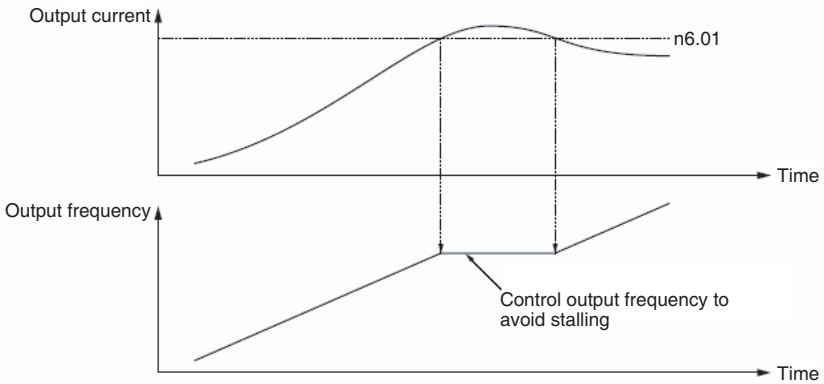

n6.02	Stall Prevention Level during Operation	Register No.	0602	Changes during operation	×
Setting range	0、20 ~ 250	Unit of setting	1%	Default setting	170

- This function will decrease the output current if it exceeds the set current value, to avoid stalling during operation. Acceleration will start again when the output current is less than the setting value, to return to the original frequency command value.
- Set the percentage of stall prevention level during operation based on the inverter rated output current as 100%.
- Set the acceleration when output frequency is going down and accelerating again, according to the acceleration/ deceleration time (n1.09 ~ n1.12) setting.
- The default setting does not need any changes in normal operation. Decrease the setting value if the capacity of the motor is smaller than that of the Inverter or the motor stalls with the default value.
- The setting value is normally 2 times as the rated current of the motor. Set the percentage of this current based on the inverter rated current as 100%.

※ After n6.02 = 0 is set, stall prevention function during operation will be disabled.

### 【Stall prevention function during operation】

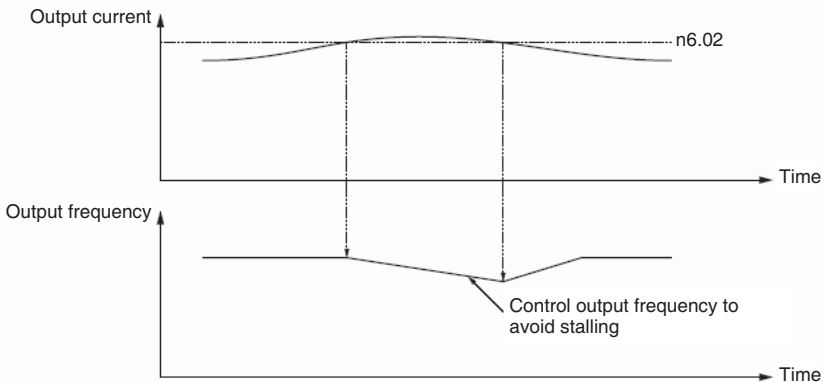

### 6-10 Other Functions

The following description provides information on other functions and parameter settings than those of [Chapter 5 Basic Operation] and former part in this chapter (Advanced Operation).

Refer to [Chapter 7 Communications] for parameters related to communications.

#### 6-10-1 Motor Protection Function (n6.06, n6.07)

The detection characteristics of motor protection function can be changed according to the performance of motor.

n6.06	Motor Protection Function Selection	Register No.	0606	Changes during operation	×
Setting range	0 ~ 2	Unit of setting	1	Default setting	0

- Set the constants of protection characteristics for motor overload detection (OL1) according to the type of used motor.
- If a single inverter is connected to more than one motor, the electronic thermal function protecting motor from overheating will not function normally.  
Set n6.06 (selecting motor protection function) = 2 to disable electronic thermal function, then set thermal protection devices outside every motor.

#### 【Explanation of the setting values】

Setting value	Description
0	The protection corresponding to universal induction motor
1	The protection corresponding to inverter dedicated motor
2	Protection function for motor overload is disabled.

※ Be sure to set motor rated current (n7.00) so that electronic thermal function can detect the motor overload (OL1) correctly.

n6.07	Motor Protection Time	Register No.	0607	Changes during operation	×
Setting range	30 ~ 600	Unit of setting	1s	Default setting	60

- Set the electronic thermal protection time constant of motor overload detection (OL1) in second. Default setting is 150% 1 minute.
- The default setting does not need any changes in normal operation.
- To set the parameter according to the characteristics of the motor, confirm the thermal time constant with the motor manufacturer and set the parameter with some margin (shorter than the thermal time).
- To detect motor overloading more quickly, reduce the set value, provided that it does not cause any application problems.

### 6-10-2 Operation After recovery From Momentary Power Interruption/Operation After External Base Electrode Blocking is Cancelled (n8.04-n8.08)

Inverter operation after momentary power interruption occurred can be selected.

Additionally, in order to make the device start stably, the rpm of motor rotating by inertia will be detected and speed detection function will be set when restarting after momentary power interruption or canceling external base electrode blocking input.

#### ■ Operation selection after recovery from momentary power interruption and speed detection selection after external base electrode blocking is cancelled

n8.04	Operation election after recovery from momentary power interruption	Register No.	0804	Changes during operation	×
Setting range	0 ~ 2	Unit of setting	1	Default setting	0

- Set the process method after momentary power interruption occurred.
- During continuous operation, it will just hold the setting time in n8.05 (momentary power interruption compensation time).

#### 【Explanation of the setting values】

Setting value	Description
0	Not continue operation (freely slide to stop after "Lv" error detection)
1	Continue operation (speed detection restarts from bottom to top)
2	Continue operation (speed detection restarts from top to bottom)

n8.05	Time of Momentary Power Interruption	Register No.	0805	Changes during operation	×
Setting range	0.1 ~ 5.0	Unit of setting	0.1s	Default setting	2.0

- Set the maximum hold time when the process method after momentary power interruption is set as continue operation.
- When momentary power interruption occurs after the set time, "Lv" error will be detected and operation will stop.
- Common start instead of speed detection will be performed when the set time is long and power inside inverter is lowered to minimum.

## Chapter 6 Advanced Operation

### 6-10-3 Cooling Fan Operation Selection (n3.08)

n3.08	Cooling Fan Operation Selection	Register No.	0308	Changes during operation	×
Setting range	0 ~ 3	Unit of setting	1	Default setting	1

- Set the operation for cooling fan.
- If stopped for a long time without fan operation, the life of the fan will be enlarged and noise will be reduced.
- Keep the fan to operate under the overheating environment where overheating of fins is detected.

#### 【Explanation of the setting values】

Setting value	Description
0	The fan will always rotate during power input
1	Fan rotates during the operation of inverter (fan rotates for one minute after the inverter stops)
2	Fan rotates during the operation of inverter (fan stops rotating after the inverter stops)
3	Fan rotates under IGBT temperature (rotate above 60 °C , stop under 40 °C )

### 6-10-4 Fault Retry Function (n8.15)

n8.15	Number of Fault Retries	Register No.	0816	Changes during operation	×
Setting range	0 ~ 10	Unit of setting	1	Default setting	0

- The function will reset and restart the device automatically when overvoltage (ov) or over current (oc) occurs. Set the maximum number of restarts.
- ※ When restarting after fault retry, the device will start through the speed detection from frequency command.

### 6-10-5 Frequency Jump Function (n8.09 ~ n8.12)

n8.09	Upper Limit of Jump Frequency 1	Register No.	0809	Changes during operation	×
Setting range	0.00 ~ 600.0	Unit of setting	0.01Hz	Default setting	0.00
n8.10	Lower Limit of Jump Frequency 1	Register No.	080A	Changes during operation	×
Setting range	0.00 ~ 600.0	Unit of setting	0.01Hz	Default setting	0.00
n8.11	Upper Limit of Jump Frequency 2	Register No.	080B	Changes during operation	×
Setting range	0.00 ~ 600.0	Unit of setting	0.01Hz	Default setting	0.00
n8.12	Lower Limit of Jump Frequency 2	Register No.	080C	Changes during operation	×
Setting range	0.00 ~ 600.0	Unit of setting	0.01Hz	Default setting	0.00

- In order to avoid the resonance frequency with machines, set the jump frequency. Set the upper/lower limit of the frequency you want to jump in Hz.
- ※ Be sure to set  $n8.09 \geq n8.10 \geq n8.11 \geq n8.12$ .
- ※ Disabled when set to 0.00.

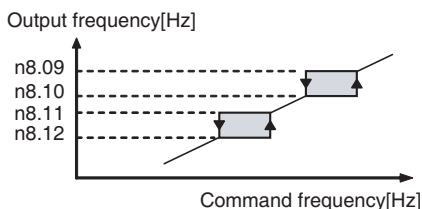

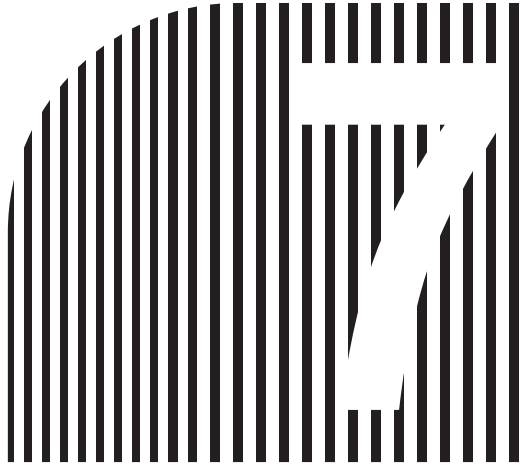

## Chapter 7

7

### ● Communications ●

- 7-1 RS485 Communication Overview
- 7-2 Inverter Settings
- 7-3 Wiring of RS485
- 7-4 Communication Basic Format
- 7-5 Communication setting method
- 7-6 Register No. assignment and content
- 7-7 Communication Error Code
- 7-8 Communication with PC
- 7-9 Ladder Program Examples
- 7-10 Communications Time

# Chapter 7 Communications

RS485 communication attached in 3G3JZ is described in this chapter.

You can communicate with SYSMAC CS series programmable controller (PLC) with MODBUS protocol.

With communication function, you can perform inverter control input, frequency reference, inverter running status monitoring and parameter setting reading/writing.

In RS-485 communication, at most 254 slaves can be connected, therefore, it can be used as a simple network system.

## 7-1 RS485 Communication Overview

### MEMOBUS Communication Structure

MEMOBUS communication consists of a host (PLC) and at most 254 slaves. The communication between host and slaves is normally as: the host starts communication, and the slaves responds.

The host can communicate with a slave simultaneously. Therefore, preset address numbers for slaves, the host performs signal communication by specifying a number. The slave which receives the command from the host gives response.

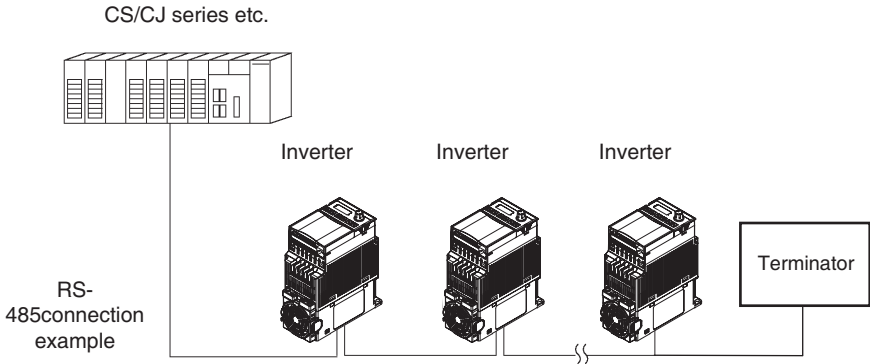

Dia. Example of connection between PLC and inverters

### Communication Specifications

Communication specifications of MEMOBUS are as follows:

Item	Specifications
Interface	RS-485
Synchronous method	Desynchrony (start-stop synchronous)
Communication parameters	Baud rate: 4800/9600/19200/38400 bps selectable Data length: 8 bits Parity: even parity Stop bit: 1 bit
Communication protocol	MEMOBUS base
No. of devices connectalbe	254 max.

## 7-2 Inverter Settings

## ■ Relevant Parameters

Constant No.	Register No. [Hex]	Name	Details	Setting range	Set unit	Default setting	Write in operation
n9.00	0900	RS485 communication slave address	Set slave address (slave number) used in communication. ※ When set to 0, RS485 communication is disabled.	0 to 254	1	0	×
n9.01	0901	RS485 communication baud rate selection	Set communication baud rate (communicate speed). 0: 4800 bps 1: 9600 bps 2: 19200 bps 3: 38400 bps	0 to 3	1	1	×
n9.02	0902	RS485 operation selection when communication error occurs	Select an operation when communication error "CE □" occurs. 0: Operation continue when an alarm is displayed 1: Ground to a halt when an alarm is displayed 2: Free stop when an alarm is displayed 3: operation continue (no warning)	0 to 3	1	2	×
n9.04	0904	RS485 communication send wait	Respond wait time after receiving request information from the host is set here. Set to 1 for 2 ms.	0 to 200	1 (2ms)	0	×
n9.05	0905	RS485 communication timeout detect time	Please set a time for communication timeout limit. Take communication program into consideration when setting the timeout limit. ※ When set to 0.0, communication timeout detect is disabled.	0.0 to 120.0	0.1 s	1.0	×

7-3 Wiring of RS485

■ Communication Connector

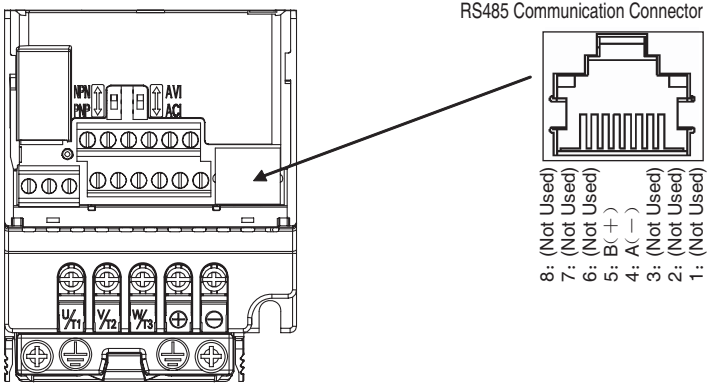

■ RS485 Communication Connector Description

	Mark		Details	Specifications
Connector pins	1p	—	(Not used)	—
	2p	—	(Not used)	—
	3p	—	(Not used)	—
	4p	A( - )	RS485 communication send/receive data	Used to send/receive signals for RS485 communication.
	5p	B( + )	RS485 communication send/receive data	※ Based on MODBUS communication protocol.
	6p	—	(Not used)	—
	7p	—	(Not used)	—
	8p	—	(Not used)	—

※ Use connectors for Ethernet. Please purchase a cable for Ethernet.

■ Terminator

Terminator needs to be wired at the end of RS485 communication. Please connect a resistor of 110 Ω , 1/2 W.

■ Example of connecting to PLC

Connector terminal arrangement and standard wiring diagram for serial communication boards/units are provided in this section.

Connector terminal arrangement of serial communication boards/units

Connector terminal arrangement of CS1W-SCB41-V1, CJ1W-SCU41-V1 and C200HW-COM06-V1 are as follows:

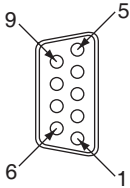

Terminal No.	Code	Signal name	I/O
1	SDA	Send data ( - )	Output
2	SDB	Send data ( + )	Output
3	NC	—	—
4	NC	—	—
5	NC	—	—

Terminal No.	Code	Signal name	I/O
6	RDA	Receive data ( - )	Input
7	NC	—	—
8	RBD	Receive data ( + )	Input
9	NC	—	—
Frame	FG	FG	—

Standard Wiring Diagram

The following diagram is the wiring for RS-485.

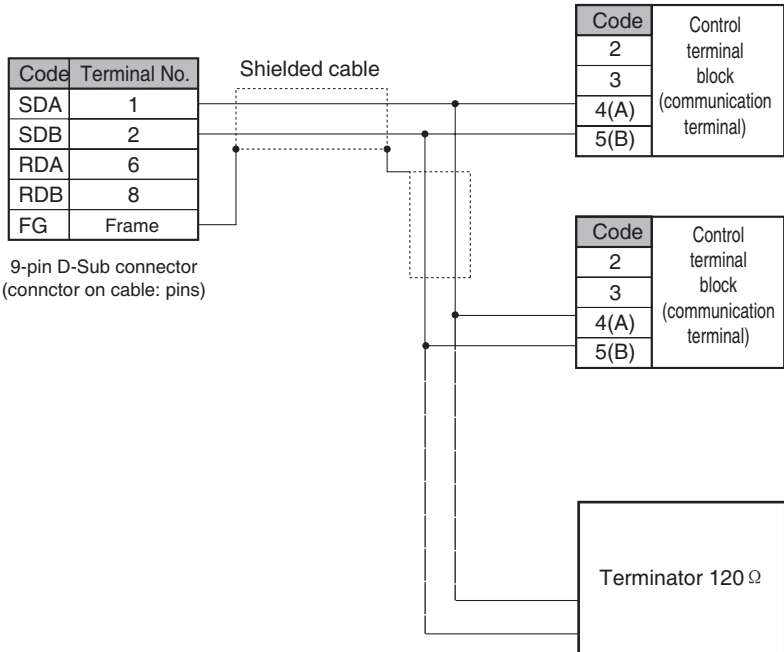

Dia. RS-485 Wiring Diagram

**7-4 Communication Basic Format**

**Message Format**

In RS-485 communication, hosts send commands to slaves, slaves give responses to hosts. Set the format of message send/receive as below, data length is change by commands (functions).

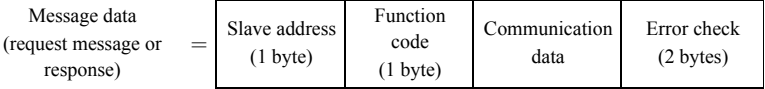

The space between messages must be as below:

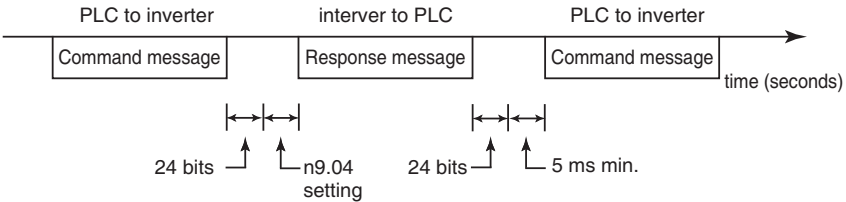

**Message format in RTU Mode**

Start	No-record time interval longer than 10 ms
Address	Communication address: 8-bit address
command	Communication code: 8-bit command
Data (n-1) to data 0	data content: $n \times 8$ -bit data, $n \leq 20$
CRC parity higher bytes	CRC parity: 16-bit check code with 2 8-bit check data
CRC parity lower bytes	
End	No-record time interval longer than 10 ms

**Slave address**

The addresses for inverters are 1 ~ 254(1 ~ FE hex).

**Function code**

Used to specify an command. Function code has 4 types as below.

Function code (Hex)	Function
03H	Reads the content of register
10H	Writes to multi registers

**Data**

Memory register No. (test code when numbering) and its data form a series of data. Data length may change according to the command.

**Error detection**

Check communication errors with CRC-16 or LRC. Calculate with following procedure:

- 1.CRC-16(LRC) is set to 0 as default normally. Please set MEMOBUS system setting to -1 (1 for 16 digits) as default;
- 2.Use LSB of slave as MSB, MSB of final data as LSB, work out CRC-16 (LRC);
- 3.Work out CRC-16(LRC) from the response information from the slave, and verify it in the CRC-16(LRC) of the response information.

## MEMOBUS Information Example (use MODBUS RTU as example)

Example of MEMOBUS information on command/response

### Read the content of memory register

Reads the contents of the registers which corresponds to specified continue No. from specified No. The content of registers are divided into 8 higher bits and 8 lower bits. They become data of response information in No. sequence.

Example of reading inverter status signal, fault details, data link status and frequency reference from slave 2 is as below.

command signal			Response signal (normal)			Response signal (error)		
Slave address		02H	Slave address		02H	Slave address		02H
Function code		03H	Function code		03H	Function code		83H
Start No.	Higher bits	21H	Number of data		08H	Error code		10H
	Lower bits	20H	Start memory register	Higher bits	00H	CRC-16	Higher bits	B0H
Amount	Higher bits	00H		Lower bits	65H		Lower bits	FCH
	Lower bits	04H	Next memory register	Higher bits	00H	CRC-16	Higher bits	B0H
CRC-16	Higher bits	4FH		Lower bits	00H		Lower bits	FCH
	Lower bits	CCH	Next memory register	Higher bits	00H	CRC-16	Higher bits	B0H
CRC-16	Higher bits	4FH		Lower bits	00H		Lower bits	FCH
	Lower bits	CCH	Next memory register	Higher bits	01H	CRC-16	Higher bits	B0H
CRC-16	Higher bits	4FH		Lower bits	F4H		Lower bits	FCH
	Lower bits	CCH	CRC-16	Higher bits	AFH	CRC-16	Higher bits	B0H
CRC-16	Higher bits	4FH		Lower bits	82H		Lower bits	FCH
	Lower bits	CCH	CRC-16	Higher bits	AFH	CRC-16	Higher bits	B0H
CRC-16	Higher bits	4FH		Lower bits	82H		Lower bits	FCH

### Writes to multiple memory registers

Writes the specified data to specified memory register from the specified number. Data writing must follow the sequence of registers, arranges in the sequence of 8 higher bits, 8 lower bits.

The following example is to send a communication frequency reference from PLC to slave 1 to set to forward operation at 60.0 Hz.

command signal			Response signal (normal)			Response signal (error)		
Slave address		01H	Slave address		01H	Slave address		01H
Function code		10H	Function code		10H	Function code		90H
Start No.	Higher bits	21H	Start No.	Higher bits	21H	Error code		03H
	Lower bits	01H		Lower bits	01H	CRC-16	Higher bits	0CH
Amount	Higher bits	00H	Amount	Higher bits	00H		Lower bits	01H
	Lower bits	02H		Lower bits	02H	CRC-16	Higher bits	0CH
Number of data		04H	CRC-16	Higher bits	1AH		Lower bits	01H
Start data	Higher bits	00H		Lower bits	34H	CRC-16	Higher bits	0CH
	Lower bits	01H	CRC-16	Higher bits	1AH		Lower bits	01H
Next data	Higher bits	02H		CRC-16	Higher bits	1AH	CRC-16	Higher bits
	Lower bits	58H	Lower bits		34H	Lower bits		01H
CRC-16	Higher bits	F7H	CRC-16	Higher bits	1AH	CRC-16	Higher bits	0CH
	Lower bits	68H		Lower bits	34H		Lower bits	01H
CRC-16	Higher bits	F7H	CRC-16	Higher bits	1AH	CRC-16	Higher bits	0CH
	Lower bits	68H		Lower bits	34H		Lower bits	01H

### 7-5 Communication setting method

#### ■ Register Data Transfer

Register data (such as monitor value or parameter set value) locate in communication blocks of message data (request message or response message). All data in registers are sent in 2-byte data.

#### Data is transferred to hex in min. set unit of each register

Eg., if frequency reference is 60 Hz and min. unit is 0.01 Hz, data will be transferred as below:

$$60\text{Hz}/0.01(\text{Hz})=6000=1770\text{Hex}$$

#### Monitor items

Register 2123H: frequency reference monitor

Register 2124H: frequency output monitor

#### Communication register

Register 2102H: frequency reference

#### Negative values are represented as 2S complement code

If frequency curve is -100%, min. unit will be 1%, data will be transferred as below:

$$100\%/1\%=100=0064\text{Hex}$$

2S complement code: FF9CHex

Positive or negative, depends on parameter settings.

MSB of negative value is always 1, however, data with MSB=1 is not always a negative value.

#### No data setting in unused registers

Unused registers may be used in internal treatments, do not write any data to these registers.

## 7-6 Register No. assignment and content

## ■ Data Overview

Data overview is as below. There are 3 data types, command data, monitor data and synchronous send data.

## command Data

command data overview is as below. You can read or write.

Data type	Address	Function	
Input	2100H	Not used	
	2101H	Control bit	
		Bit 0	00: Stop
		Bit 1	01: Forward
			10: Reverse
		Bit 2	11: Stop
			00: No function
		Bit 3	01: External error input
			10: Error reset
		Bit 4	11: No operation
			ComRef (1: ignore parameter setting, frequency reference specified by communication)
		Bit 5	ComCtrl (1: ignore parameter setting, control command specified by communication)
	Bit 6	Multi-function input command 3	
	Bit 7	Multi-function input command 4	
Bit 8	Multi-function input command 5		
Bit 9	Multi-function input command 6		
Bit 10 to 15	Not used		
2102H	Frequency reference		
2103H to 211FH	Not used		

## Chapter 7 Communications

Data type	Address	Function	
Output	2120H	Inverter status bit	
		Bit0	Operating (1: operating)
		Bit1	Reversing (0: forward or else / 1: reverse operation)
		Bit2	Frequency conformability (1: conformed)
		Bit3	Error display (1: error)
		Bit4	Alarm display (1: Alarm)
		Bit5	Multi-function contact output (relay output (MA/MB-MC)), 1:ON
		Bit 6 ~ Bit15	Not used
	2121H	Error code	
	2122H	Not used	
	2123H	Frequency reference monitor	
	2124H	Output frequency monitor	
	2125H	Output voltage monitor	
	2126H	Output current monitor	
	2127H	Output power monitor	
	2128H	Not used	
	2129H	AVI terminal voltage monitor	
	212AH	ACI terminal current monitor	
	212BH	Input terminal status	
		Bit 0	Multi-function contact input terminal (S1) monitor, (actual terminal voltage level status)
		Bit 1	Multi-function contact input terminal (S2) monitor, (actual terminal voltage level status)
		Bit 2	Multi-function contact input terminal (S3) monitor, (actual terminal voltage level status)
		Bit 3	Multi-function contact input terminal (S4) monitor, (actual terminal voltage level status)
		Bit 4	Multi-function contact input terminal (S5) monitor, (actual terminal voltage level status)
		Bit 5	Multi-function contact input terminal (S6) monitor, (actual terminal voltage level status)
		Bit 6 ~ Bit 15	Not used
	212CH~2130H	Not used	
	2131H	Main circuit DC voltage	
	2132H	Not used	
2133H	Power factor monitor		
2134H~2137H	Not used		

## 7-7 Communication Error Code

### ■ Error Code

Communication error code

Error Code	Explanation
01	Communication command illegal: Inverter has received an invalid command
02	Register address illegal: Inverter has received data with invalid address
03	Register value illegal: Inverter has received a communication command with invalid register value
04	Slave device fault: Inverter can not excute the requested command
06	Inverter busy
10	Communication timeout

### ■ No Response from Slave

In following cases, slaves ignore command information from hosts, and do not send response information. When executing write function, if slave address specified by command is 0, response information to the host will not be sent although all slaves are executing write.

- Error detected in command (overshooting, frame, parity or CRC-16);
- Slave address of command is differ from slave address of inverter;
- Time interval between data is longer than 24 bits;
- Length of execution information is incorrect

### Precautions

Please set the timer which monitors slave response time at the host. When the slave does not respond to the slave in time setting, please set the host to send same commands in this case.

### 7-8 Communication with PC

RS-485 communication of 3G3JZ inverter conforms to MODBUS communication protocol. This protocol does not share the same wire with other communication protocols. To use PC to control 3G3JZ with RS-485, a serial communication board/unit is needed to use protocol-macro function. Serial communication with protocol-macro needs following settings and operations.

- Set the system setting for serial communication board/unit.
- Create send/receive procedure with protocol-macro tool (CX-Protocol) according to MODBUS communication protocol, and send it to the serial communication board.
- Execute PMCR commands in the CPU of PCs.

Serial communication board or units can be mounted in following SYSMAC CPU units.

Table1 Available PCs

Series	CPU Unit Models
SYSMAC CS	CS1H-CPU67H/66H/65H/64H/63H CS1G-CPU45H/44H/43H/42H
SYSMAC CJ	CJ1H-CPU67H/66H/65H CJ1G-CPU45H/44H/43H/42H CJ1G-CPU45H/44H/43H/42H CJ1M-CPU13/12/11/23/22/21
SYSMAC C200HX/HG/HE	C200HX-CPU34-E/44-E/54-E/64-E/34-ZE/44-ZE/54-ZE/64-ZE/65-ZE/85-ZE C200GX-CPU33-E/43-E/53-E/63-E/33-ZE/43-ZE/53-ZE/63-ZE C200HE-CPU3-E/42-E/32-E/42-ZE
SYSMAC CQM1H	CQM1H-CPU61/51
SYSMAC CP1H	CP1H-X/XA/Y

#### ■ Available Serial Communication Board/unit

The following serial communication boards and units can be used at RS-422A/485 ports.

You can use RS-232C port if RS-422/485 transfer adapter is mounted. But for a simple arrangement, we recommend to use RS-422/485 port. The following information is for RS-422/485 ports.

Table2 Available Serial Communication

Series	Serial communication board/unit	Mounting method	Specifications
SYSMAC CS	CS1W-SCB41-V1	Same as CPU unit's inner board	<ul style="list-style-type: none"> <li>• One RS-232C port</li> <li>• One RS-422A/485 port</li> <li>• Protocol-macro function</li> </ul>
SYSMAC CJ	CJ1W-SCU41-V1	CPU bus unit	<ul style="list-style-type: none"> <li>• One RS-232C port</li> <li>• One RS-422A/485 port</li> <li>• Protocol-macro function</li> </ul>
SYSMAC C200HX/HG/HE	C200HW-COM06-EV1 Be sure the model has a suffix of "EV1", otherwise CRC-16 detection code can not be used.	Mount in CPU unit's optional slots	<ul style="list-style-type: none"> <li>• One RS-232C port</li> <li>• One RS-422A/485 port</li> <li>• Protocol-macro function</li> </ul>
SYSMAC CQM1H	CQM1H-CPU61/51-E	Same as CPU unit's inner board	<ul style="list-style-type: none"> <li>• One RS-232C port</li> <li>• One RS-422A/485 port</li> <li>• Protocol-macro function</li> </ul>
SYSMAC CP1H	CP1W-CIF11	Serial communication port	MODBUS simple host

## ■Peripheral Devices

The following peripheral devices are needed when using protocol-macro function

Table3 Peripheral Devices

Name	Model	Specifications	
CX-Protocol	WS02-PSTC1-E	Following peripheral devices support protocol-macro function of the whole SYSMAC series	
		Personal computer environment	
		Personal computer	IBM PC/AT or compatible computer
		CPU	Min. requirement: Pentium 90MHz Recommend: Pentium 166MHz or better
		OS	Microsoft Windows95 or Windows98
		Memory	Min.: 16MB Recommend: 24MB min.
		Hard disk	Min.: 24MB free space Recommend: 50MB free space
		Monitor	SVGA or better
Driver	FDD: 1 min. CD-ROM driver: 1 min.		
Protocol support tools	WS01-PSTF1-E	The following peripheral devices support the protocol-macro function of SYSMAC C200HX/HG/HE series	
		Personal computer environment	
		Personal computer	IBM PC/AT or compatible computer
		CPU	Min. requirement: Pentium 90MHz Recommend: Pentium 166MHz or better
		OS	Microsoft Windows95 or Windows98
		Memory	Min.: 16MB Recommend: 24MB min.
		Hard disk	Min.: 24MB free space Recommend: 50MB free space
		Monitor	SVGA or better
Driver	FDD: 1 min. CD-ROM driver: 1 min.		

## ■Manuals of Relevant Devices and Support Tools

The following manuals describe the devices and protocol support tools in detail.

Table4 Manual List

Name, Series and Model	Catalog Name
SYSMAC CS series, CPU units	W339 Operation Manual, W340 command Reference Manual, W394 Programming Manual
SYSMAC CJ series, CPU units	W393 Operation Manual, W340 command Reference Manual, W394 Programming Manual
SYSMAC C200HX/HG/HE, CPU units	W302 Installation Guide, W303 Operation Manual
SYSMAC CQM1H CPU units	W363 Operation Manual, W364 Programming Manual
Serial communication boards, CS1W-SCB21/41-V1 Serial communication units, CS1W-SCU21-V1 Serial communication units, CJ1W-SCU21/SCU41-V1	W336 User Manual
Serial communication boards, C200HW-COM01 C200HW-COM02-V1 ~ C200HW-COM06-EV1	W304 Operation Manual
Serial communication ports CP1W-CIF11	W450 Operation Manual
Serial communication boards, CQM1H-SCB41	W365 Operation Manual

## Chapter 7 Communications

Name, Series and Model	Catalog Name
CX-protocol, WS02-PSTC1-E	W344 Operation Manual
Protocol support tools WS01-PSTF1-E	W319 Operation Manual

### ■ Serial Communication Boards/Units System Setting

Serial communication boards/units system settings are as below.

For CS/CJ series:

Use following ports for CS/CJ series.

- CS1W-SCB41 serial communication board: port 2
- CJ1W-SCU41 serial communication unit: port 2

$$m = D30000 + 100 \times \text{Unit No. (Wd)}$$

DM Area				Bit	Setting	Value
CS1W-SCB41-V1		CJ1W-SCU41-V1				
Port 1	Port 2	Port 1	Port 2			
D32000	D32010	m	m+10	15	setting-0: default, 1*: expected setting	860E
				14 ~ 12	Reserved	
				11 ~ 08	Serial communication mode (6Hex*: protocolmacro)	
				07 ~ 05	Reserved	
				04	Start bit-0*: 1bit, 1: 1 bit (Always 1 bit, regardless of the setting)	
				03	Data length-0: 2 bits, 1*: 1 bit	
				02	Stop bit-0: 2bits, 1*: 1 bit	
				01	Parity-0: yes, 1*: no	
				00	Parity-0: even, 1: odd	
D32001	D32011	m+1	m+11	15 ~ 04	Reserved	0006
				03 ~ 00	Transmission rate (unit: bps) 0: default (9,600), 3: 1,200, 4: 2,400, 5: 4,800, 6*: 9,600, 7: 19,200, 8: 38,400	
—	—	—	—			—
D32008	D32018	m+8	m+18	15	Transmission method-0: half duplex, 1*: full duplex	8000
				14 ~ 00	Reserved	
D32009	D32019	m+9	m+19	15 ~ 00	Max. number of bytes when sending/ receiving data-00C8* to 03E8 Hex	00C8

\* Set to this value.

For SYSMAC C200HX/HG/HE and CQM1H series:

Use following ports for SYSMAC C200HX/HG/HE and CQM1H series.

- C200HW-COM06-V1 communication board: port A
- CQM1H-SCB41 serial communication board: port 2

Communication board		Bit	Setting	Value																																																													
Port 1 Port A	Port 2 Port B																																																																
DM6555	DM6550	00 ~ 03	Standard format setting 0Hex: Standard setting (default) 1Hex*: The setting in bit 00 to 15 of DM6656 and DM6551 are used.	6001																																																													
		04 ~ 11	00: Default																																																														
		12 ~ 15	Serial communication board 0Hex: Host link (default) 1Hex: non-protocol 2Hex: 1: 1 link slave 3Hex: 1: 1 link slave 4Hex: NT Link (1: 1 mode) 5Hex: Hex: NT Link (1: 1 mode) 6Hex*: protocol macro																																																														
DM6556	DM6551	00 ~ 07	Communication speed 00Hex: 1,200bps (default) 01Hex: 2,400bps 02Hex: 4,800bps 03Hex*: 9,600bps 04Hex: 19,200bps	0803																																																													
		08 ~ 15	Frame format																																																														
			<table border="1"> <thead> <tr> <th></th> <th>Start bit</th> <th>Data Stop</th> <th>bit</th> <th>Parity</th> </tr> </thead> <tbody> <tr> <td>00Hex:</td> <td>1</td> <td>7</td> <td>1</td> <td>Even(default)</td> </tr> <tr> <td>01Hex:</td> <td>1</td> <td>7</td> <td>1</td> <td>Odd</td> </tr> <tr> <td>02Hex:</td> <td>1</td> <td>7</td> <td>1</td> <td>No</td> </tr> <tr> <td>03Hex:</td> <td>1</td> <td>7</td> <td>2</td> <td>Even</td> </tr> <tr> <td>04Hex:</td> <td>1</td> <td>7</td> <td>2</td> <td>Odd</td> </tr> <tr> <td>05Hex:</td> <td>1</td> <td>7</td> <td>2</td> <td>No</td> </tr> <tr> <td>06Hex:</td> <td>1</td> <td>8</td> <td>1</td> <td>Even</td> </tr> <tr> <td>07Hex:</td> <td>1</td> <td>8</td> <td>1</td> <td>Odd</td> </tr> <tr> <td>08Hex*:</td> <td>1</td> <td>8</td> <td>1</td> <td>No</td> </tr> <tr> <td>09Hex:</td> <td>1</td> <td>8</td> <td>2</td> <td>Even</td> </tr> <tr> <td>10Hex:</td> <td>1</td> <td>8</td> <td>2</td> <td>Odd</td> </tr> <tr> <td>11Hex:</td> <td>1</td> <td>8</td> <td>2</td> <td>No</td> </tr> </tbody> </table>			Start bit	Data Stop	bit	Parity	00Hex:	1	7	1	Even(default)	01Hex:	1	7	1	Odd	02Hex:	1	7	1	No	03Hex:	1	7	2	Even	04Hex:	1	7	2	Odd	05Hex:	1	7	2	No	06Hex:	1	8	1	Even	07Hex:	1	8	1	Odd	08Hex*:	1	8	1	No	09Hex:	1	8	2	Even	10Hex:	1	8	2	Odd	11Hex:
	Start bit	Data Stop	bit	Parity																																																													
00Hex:	1	7	1	Even(default)																																																													
01Hex:	1	7	1	Odd																																																													
02Hex:	1	7	1	No																																																													
03Hex:	1	7	2	Even																																																													
04Hex:	1	7	2	Odd																																																													
05Hex:	1	7	2	No																																																													
06Hex:	1	8	1	Even																																																													
07Hex:	1	8	1	Odd																																																													
08Hex*:	1	8	1	No																																																													
09Hex:	1	8	2	Even																																																													
10Hex:	1	8	2	Odd																																																													
11Hex:	1	8	2	No																																																													

\* Set to this value.

# Chapter 7 Communications

## ■ Protocol Macro Function

The protocol macro function makes it possible to customize a communications protocol in order to create a macro according to the specifications of the serial communications port of a general-purpose peripheral device.

The protocol macro function is mainly used for the following jobs.

- Creation of the message communications frame
- Creation of Send & Recv procedures for the message communications frame



### TERMS

This manual uses the terms “message, DSR message, and response” to express the communications data exchanged.

Message: A DSR message or response.

DSR message: A message sent by the Master for commands to the Inverter.

Response: A message that the Inverter returns in compliance with a DSR message from the MasterTERMS Master.

## Creating a Message

The message can be created according to the communications specifications of the general-purpose peripheral device (Inverter) as a counterpart. A DSR message can include variables to set data in the I/O memory (such as data memory) of the CPU Unit or write response data to the I/O memory. Each component of a message is in the memory of the Communications Board. Therefore, the CPU Unit can just execute the PMCR command to send or receive the data, with no need to write ladder programs for the communications protocol.

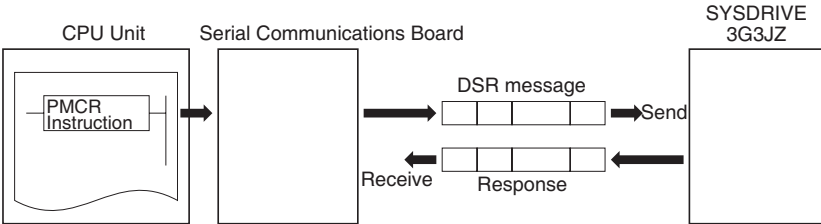

## Step to Send and Receive Messages

Sending and receiving messages as a single step includes step-type commands, such as Send, Recv, Send &Recv, and Wait commands.

The step can be finished or switched to another step according to the result of the step.

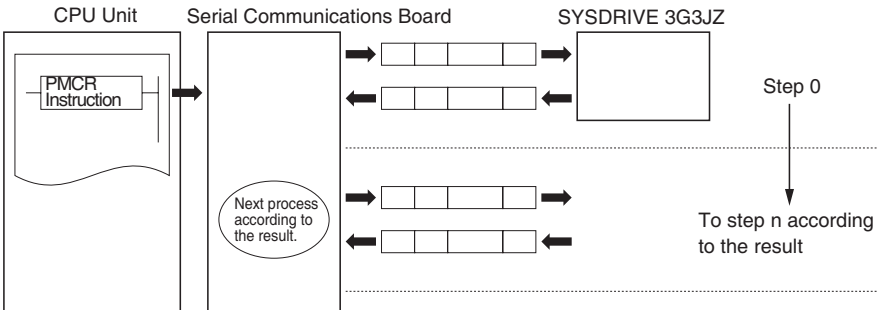

■ Configuration of the Protocol Macro Function

The protocol consists of one or more sequences. A sequence is an independent set of actions to perform together with a general-purpose peripheral device, such as an Inverter. For example, the RUN command and the frequency reference are given to the Inverter and the status of the Inverter is read in a single sequence. A sequence consists of one or more steps. A step consists of a Send & Recv command + a Send & Recv message + a step branch in accordance with the processing result + Completion.

Sequence

When repeating actions to give the RUN command and frequency reference to the Inverter and read the status of the Inverter, for example, the actions can be registered as one sequence, or more than one if necessary. In "Creating a Project File", an example is shown with all actions registered as a single sequence. A sequence may include the following parameters.

Parameter	Description
Transmission control	Set the method of control, such as flow control. Select only modem control for communications with the 3G3JZ.
Link word	Set the area for sharing the data between the Programmable Controller and Communications Board. In "Creating a Project File", an example is shown without such an area set.
Monitor time	Set the periods to monitor the transmission and reception steps with timers Tr, Tfr, and Tfs. Set a period of approximately 0.5 s each for communications with the 3G3JZ.
Response notify method	A method to write reception data to the I/O memory of the Programmable Controller. Select "notify by scan" for communications with the 3G3JZ.

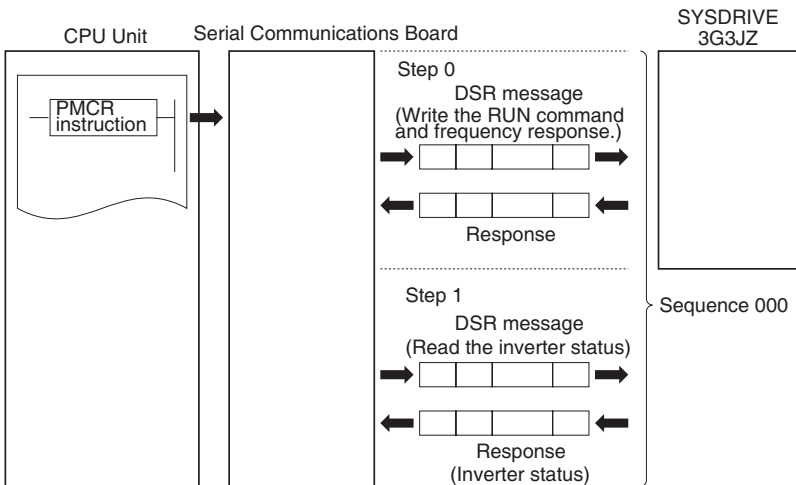

## Chapter 7 Communications

### Step

In a single step, a DSR message is sent and a response for the DSR message is received. A step may not include a response if it is a broadcast message. In the case of repetitive actions to issue the RUN command and frequency reference to the Inverter and read the status of the Inverter, for example, the actions to give the RUN command and frequency reference constitute one step. The reason is that these register numbers are consecutive and can be sent with a single DSR message. The action to read the status of the Inverter is another step. A step includes a command and a maximum of two messages. The above example uses the Send & Recv command. The DSR message and response are both messages.

A step may include the following parameters.

Parameter		Description
Command		The Send, Recv, Send & Recv, Wait, Flush, Open (ER-ON) or Close (ER-OFF) is set. Under "Creating a Project File", an example is shown with the Send & Recv command used. The Send command is used for a broadcast message.
message	Send message	A DSR message is set for the Send command used.
	Recv message	A response is set for the Recv command.
	Send & Recv message	A DSR message and response are set for the Send & Recv command.
	Recv matrix	If there are two or more responses for the Send or Send & Recv command, the next process is selected per response.
Repeat counter		The number (N) of times to repeat the step is set within a range from 0 to 255. It is possible to change messages by making use of the number (N). Under Creating a Project File, an example is shown with this function used for enabling three Slaves to repeat the same process.
Number of retries		The number of times to retry the command can be set within a range from 0 to 9 only when the Send & Recv command is used.
Send Wait Time		The waiting time until data is sent with the Send or Send & Recv command executed.
Response Write (with operand specified)		Determines whether or not to write the reception data in the response. Under Creating a Project File, an example is shown with this function used for writing the Inverter status to the memory.
Next process		Determines which step is to be processed next, or finishes the operation after the step is finished normally.
Error processing		Determines which step is to be processed next, or finishes the operation, if the the step has an error.

**■ Data Created by Protocol Support Tool and CX-Protocol**

A project file is used by the Protocol Support Tool to create and control data. A project file consists of the following data.

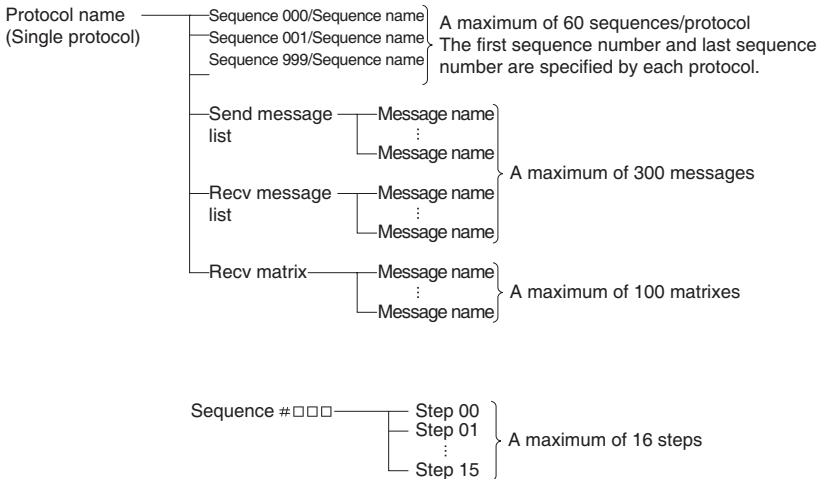
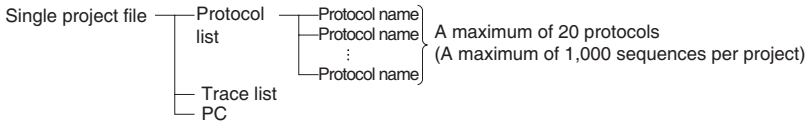

The standard system protocol incorporated by the Communications Board cannot be edited or transferred. To make use of the standard system protocol, copy it to the project file and edit it. Under Creating a Project File, an example to create a new project file is shown without making use of the standard system protocol.

**■ Creating a Project File**

The following description provides information about how to create a project file to send the RUN command and frequency references to three Inverters and read the Inverter status. ( “PST” indicates the WS01-PSTF1-J Protocol Support Tool.)

First, select from I/O items, monitor items, and parameters the data to be exchanged according to the application.

Then consider what sequence is required by using the protocol macro function.

Example: Writes control input items (such as the RUN command and multi-function input) of the Inverter and frequency reference, monitors the control output (such as error output and RUN output) of the Inverter, and monitors the Inverter status.

Three Inverters with Slave addresses from 01 to 03 are installed for communications.

**Checking the Register Numbers**

In the above example, the following three registers are required.

Control Input: Register 0001 Hex for RUN command

Frequency Reference: Register 0002 Hex

Control Output: Register 002C Hex for Inverter status



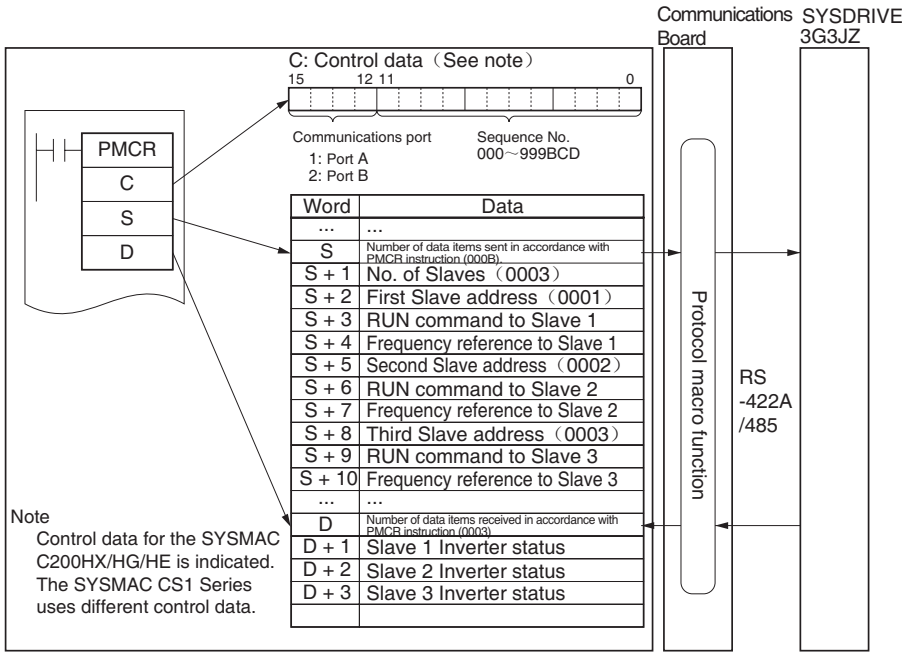

SYSMAC C200HX/HG/HE or CQM1H Programmable Controllers

### ■ Creating a New Project and Protocol

Use the following procedure to create a new project and protocol.

1. Select New from File in the Menu Bar or click on the New icon with the left button of the mouse to create a new project.
2. If CX-Protocol is used, set the PC name, PC model, and network type according to the actual conditions. The network type refers to the type of the network connected to the Support Software and it does not refer to the communications configuration between the Programmable Controller and the SYSDRIVE 3G3JZ. The above settings will not be displayed if the PST is used.
3. Double-click on New Project with the left button of the mouse to display Protocol List.
4. Click on Protocol List with the left button of the mouse and click on a blank space with the right button of the mouse.
5. Select Create Protocol.

# Chapter 7 Communications

## ■ Creating a Sequence

Use the following procedure to create a new sequence.

1. Click on New Protocol with the left button of the mouse. Then click on a blank space with the right button of the mouse.
2. Select Create Communication Sequence.

The following table will appear. Set the parameters related to the sequence in the table.

*	#	Communication sequence	Link word	Control	Response	Timer Tr	Timer Tfr	Timer Tfs
	000	Inverter I/O Send & Recv	--	Set (Setting required)	Scan	0.5	0.5	0.5

#

Sequence number. The sequence number is automatically set.

### Communication Sequence

The label (name) of the sequence. Input an appropriate, easy-to-distinguish name.

### Link Word

Set the area for sharing the data between the Programmable Controller and Communications Board.

In this example, the link word is specified by the operand of the PMCR command. Therefore no link word is set here.

### Control

Set the control method, such as flow control.

Select only “modem control” for communications with the 3G3JZ.

### Response

A method to write reception data to the I/O memory of the Programmable Controller.

Select “notify by scan” for communications with the 3G3JZ.

### Timer Tr, Timer Tfr, and Timer Tfs

Set the periods to monitor the transmission and reception steps with timers Tr, Tfr, and Tfs. The following timing chart shows the meaning of each monitor.

Be sure to set the periods according to the applications.

The step will be retried if the step is not completed within the monitor periods. An error will occur if the step is not completed within the monitor time again.

Set a period of approximately 0.5 s each for communications with the 3G3JZ.

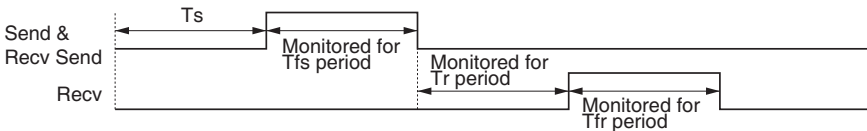

Ts: Send wait time set per step. Nothing is sent during this period.

Tfs: Monitors the completion of the data sent. If the data transmission is not finished within this period, the data will be re-transmitted.

Tr: Monitors the response to be received. If the response is not returned within this period, the response will be re-transmitted.

Tfr: Monitors the reception completion of the response. If the response transmission is not finished within this period, the response will be re-transmitted.

Note, If the Tr period is too long, the time to detect a communications error will be longer, during which the Inverter cannot be controlled. Therefore, be sure to set an appropriate period.

## ■ Creating a Step

1. Double-click on New Protocol with the left button of the mouse.
2. Click on New Sequence with the left button of the mouse and click on a blank space with the right button of the mouse.
3. Select Create Step.

The following table will appear. Set the parameters related to the step in the table.

* Step	Repeat	Command	Retry	Send wait	Send message	Recv message	Response	Next	Error
<input type="checkbox"/> 00	Reset/R(1)	Send & Recv	3	0.02	Input send	Input response	Yes	Next	Abort
<input type="checkbox"/> 01	Reset/R(1)	Send & Recv	3	0.02	Status	Read response	Yes	End	Abort
<input type="checkbox"/>									

### Step

Step number. The step number is automatically set.

### Repeat

The number (N) of times to repeat the step is set within a range from 0 to 255. It is possible to change messages by making use of the number (N).

In this example, the same message is sent to three Slaves with addresses different to each other. Therefore, the number is set to 3 in word S + 1. The number of Slaves is specified by the operand. Therefore, select Channel, use the Edit command to set Data Address to Operand, and set 0N + 1 in order to select word S + 1. In the above table, "Reset" means that the repeat counter must be reset first in the step.

### Command

Set the commands, such as Send, Recv, and Send & Recv.

Only the Send & Recv command is used for communications with the 3G3JZ except for broadcasting messages, in which case the Send command is used.

### Retry

Set the number of times to retry the command within a range from 0 to 9.

It is recommended that the number be set to 3 or larger. If a transmission error occurs due to noise, the transmission of the command will be retried. If the number is set to 3, an error will be detected if the transmission fails three times.

### Send Wait

The waiting time until the data is sent.

For communications with the 3G3JZ, if data is repeatedly transmitted to the same Slave, set the waiting time to 20 ms or more.

### Send Message and Recv Message

Set the labels of the DSR message and response to be used.

Make these settings after deciding the labels in Send Message Detail Settings and Recv Message Detail Settings.

### Response

Determine whether or not to write the reception data in the response.

Always set this parameter to Yes for communications with the 3G3JZ.

### Next

Determine which step is to be processed next or finish the operation after the step finishes normally.

In this example, step 00 is set to Next and step 01 is set to END because the sequence completes by executing steps 00 and 01.

### Error

If the step has an error, determine which step is to be processed next or finish the operation.

In this example, the parameter will be set to Abort to interrupt the sequence if an error occurs.

# Chapter 7 Communications

## ■ Send Message Detail Settings

1. Click on Send Message List with the left button of the mouse, and then click on a blank space with the right button of the mouse.

2. Select Create Send Message. The following table will appear. Set the send message in the table.

*	Message name	Header (h)	Terminator (t)	Check code (c)	Length (l)	Address (a)	Data ( )
<input type="checkbox"/>	Input send			~CRC-16(65535) (2Byte BIN)	(0)(1Byte BIN)	~(R(3N+2),1)	<a>+[10]+[00]+[01]+[00]+[02]+ <1>+(R(3N+3),4)+<c>
<input type="checkbox"/>	Status			~CRC-16(65535) (2Byte BIN)		~(R(3N+2),1)	<a>+[03]+[00]+[2C]+[00]+[01]+ <c>
<input type="checkbox"/>							

### Message name

The label (name) of the sequence. Input an appropriate, easy-to-distinguish name.

Set the label in the send message box in the table shown under Creating a Step.

### Header <h> and Terminator <t>

Set the header and terminator.

No header or terminator is used for communications with the 3G3JZ. Therefore, set both to None.

### Check code <c>

Set the check code.

The CRC-16 check code is used for communications with the 3G3JZ. Select the CRC-16 check code and set the default value to 65535.

Select Reverse for the conversion method. Then select BIN for data type.

### Length <l>

Set the length of the data.

All communications with the 3G3JZ are performed in byte units. Select 1 Byte and BIN. Select No for reading data because there is no data to be read.

### Address <a>

Set the addresses of the Slaves.

In this example, the Slave addresses are set in S + 2, S + 5, and S + 8. Therefore, retrieve the data from those locations.

The address is set in the LSB of each word. To read the byte, select Variable Reverse, otherwise the data is read from the MSB. Then click on Edit Variable with the left button of the mouse. Select Read R ( ) and set Data/Address to the operand (3N + 2) using the number (N) of times to repeat the step.

Data

Set the DSR message in detail.

- DSR Message Requesting that the RUN Command and Frequency Reference Be Written

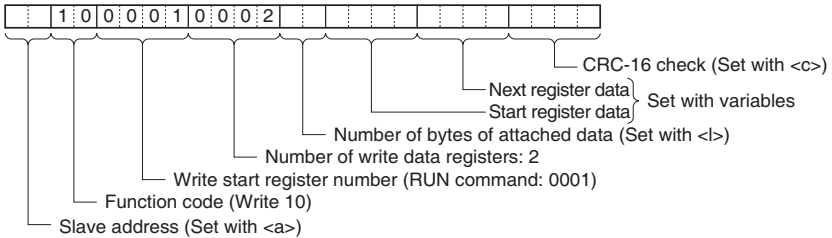

Set data →

⟨a⟩

The Slave address is set in the address box. Insert the address with the Insert icon.

[10]+[00]+[01]+[00]+[02]

Set the constants contained in the DSR message.

Use Set Constant and set the constants in Hex.

⟨l⟩

The length is set in the length box. Insert the length by using the Insert icon. The length is the number of bytes of the succeeding data (R(3N + 3), 4). The length is automatically set by the CX-Protocol.

(R(3N + 3), 4)

The Inverter's actual data to be sent. This example selects Variable and Read R() and sets the operand. Set Data to 3N + 3 because the RUN command data uses four bytes each from S + 3, S + 6, and S + 9.

Set Edit Length to 0N + 4 so that it will be set to four bytes.

⟨c⟩

The check code is set in the check code box. Insert the check code by using the Insert icon. All the data including the address data before the check code is operated. Mark all the items if the PST is used. The check code is automatically set by the CX-Protocol.

- Response to Read the Inverter Status

The DSR message to read the Inverter status from register 002C Hex consists of the following items.

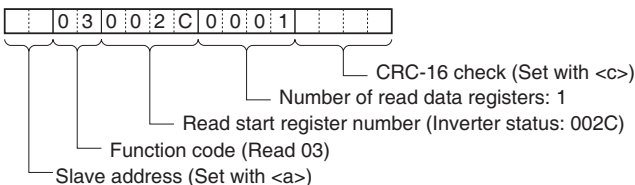

Set data →

Set the address data, constant data, and check code data.

## Chapter 7 Communications

### ■ Recv Message Detail Settings

1. With the left button of the mouse, click on Receive Message List. Then click on a blank space with the right button of the mouse.

2. Select Create Receive Message.

The following table will appear. Set the Receive message in the table.

*	Message name	Header (h)	Terminator (t)	Check code (c)	Length (l)	Address (a)	Data ( )
<input type="checkbox"/>	Input response			~CRC-16(65535) (2Byte BIN)		~(R(3N+2),1)	(a) +[10]+[00]+[01]+[00]+[02]+ (c)
<input type="checkbox"/>	Read response			~CRC-16(65535) (2Byte BIN)	(0)(1Byte BIN)	~(R(3N+2),1)	(a) +[03]+ (l) +(W(1N+1),2) + (c)
<input type="checkbox"/>							

#### Message

The label (name) of the response. Input an appropriate, easy-to-distinguish name.

Set the label in the Recv message box in the table shown under Creating a Step.

#### Header <h> and Terminator <t>

Set the header and terminator.

No header or terminator is used for communications with the 3G3JZ. Therefore, set both to None.

#### Check Code <c>

Set the check code.

The CRC-16 check code is used for communications with the 3G3JZ. Select the CRC-16 check code and set the initial value to 65535.

Select Reverse for the conversion method. Then select BIN as the data type.

#### Length <l>

Set the length of the data.

All communications with the 3G3JZ are performed in byte units. Select 1 Byte and BIN. Select No for reading data because there is no data to be read.

#### Address <a>

Set the addresses of the Slaves.

In this example, the Slave addresses are set in S + 2, S + 5, and S + 8. Therefore, retrieve the data from those locations.

The address is set in the LSB of each word. To read the byte, select Variable Reverse, otherwise the data will be read from the MSB. Then click on Edit Variable with the left button of the mouse. Select Read R ( ) and set Data/Address to the operand (3N + 2) using the number (N) of times to repeat the step. Set Edit length to 1 byte as a default. If the default value has been changed, set it to 0N + 1.

Data

Set the expected response in detail.

• Response to the RUN Command and Frequency Reference

The response to the DSR message written consists of the following items.

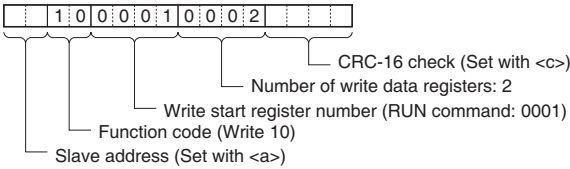

Set data →

⟨a⟩

The Slave address is set in the address box. Insert the address with the Insert icon.

[10]+[00]+[01]+[00]+[02]

Set the constants contained in the response.

Use Set Constant and set the constants in Hex.

⟨c⟩

The check code is set in the check code box. Insert the check code by using the Insert icon.

All the data including the address data before the check code is used.

Mark all the items if the PST is used. The check code is automatically set by the CX-Protocol.

• Response to the Inverter Status Read

The response to the DSR message to request the Inverter status in register 002C Hex consists of the following items.

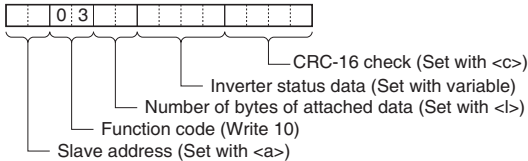

Set data →

⟨a⟩, [03], ⟨c⟩

The address data, constant data, and check code data are the same as the above.

⟨l⟩

The length is set in the length box. Insert the length by using the Insert icon. The length is the number of bytes of the succeeding data (W(1N + 1), 2). The length is automatically set by the CX-Protocol.

(W(1N+1),2)

The Inverter's actual data is to be sent. This example selects Variable and Write W () and sets the operand. Set the data to 1N + 1 because the RUN command data uses two bytes each from D + 1, D + 2, and D + 3.

Set Edit Length to 0N + 2 so that it will be set to two bytes.

## 7-9 Ladder Program Example

### ■ Ladder Program

Connect the PST and the Communications Board, and read the Communications Board system settings from the PST. Set the start/stop bits both to 1 bit, and data length to 8 bits.

Transfer the created protocol to the Communications Board. The following example describes how to control the Inverter with this protocol.



重要

- Before using this program in your system, be sure to check the word and data memory allocations and change them if necessary so that there will be no word or data memory duplication.
- This program will stop all communications if a communications error or fault occurs. Be sure to set communications error detection n9.05  $\neq$  0.0 and n9.02 for communications error detection operation selection to 1 or 2 so that the system will stop with time-over detection.

### ■ Memory Allocations

Word	Functions common to all Slaves
00000	Inverter control communications (continued when set to ON)
00001	Communications error output (on hold when a communications error or fault occurs)
00002	Communications fault reset

### Frequency References of Inverter

The frequency references of the Inverter for register 2102 frequency references are listed in the following table.

DM	Function
D0	Slave 1 frequency reference

### Inverter Control Inputs (Register 2101 Command)

Word	Slave 1 function	
210100 210111 (others stop)	01	Forward
	10	Reverse
210102 210103 (others disable)	01	External fault
	10	Fault reset
210104	ComRef	
210105	ComCtrl	
210106	Multi-function input 3	
210107	Multi-function input 4	
210108	Multi-function input 5	
210109	Multi-function input 6	
210110~210115	Not used	

### Inverter Control Outputs (Register 2120 Inverter Status)

Word	Slave 1 function
212000	During RUN (1: During RUN)
212001	During Reverse
212002	Frequency agree
212003	Error display
212004	Alarm display
212005	Multi-function contact output (Relay output (MA/MB-MC)), 1: ON
212006~212015	Not used

### Area Used by Operand of PMCR command

The area used by the operand of the PMCR command in the CS-series is shown here.

Control Data: C1

DM	Word
D0100	0 1 1 1 0 0 1 0 1 1 1 0 0 0 0 1

Communications port 7   Serial port 2   Communications port E1

Control Data: C2

DM	Word
D0101	0 0 0 0 0 0 0 0 0 0 0 0 0 0 0 0

Sequence 000 set

Send Data: S

DM	Area
D1000	0005 (Number of Send data items: 5) (See note 1)
D1001	0001(Number of Slaves)
D1002	0001(Slave address)
D1003	Control input to Slave 1
D1004	Frequency reference to Slave 1

Recv Data: D

DM	Area
D2000	0001 (Number of Recv data items: 1) (See note 2)
D2001	Slave 1 Inverter status

Note 1. Set the number of Send data items in Hex to the number of words of D1000 through D1004(5).

Note 2. The number of words of D2001 is written in Hex for the number of Recv data items.

### Status Flags

- Communications Port Enabled Flag  
Flag bit for communications port 7: A20207

- Protocol Macro Execution Flag

The Protocol Macro Execution Flag is described below.

Unit/ Board	Port 1	Port 2
CS1 Board	CIO 190915	CIO 191915
CS1 Unit	Bit 15 of CIO n + 9	Bit 15 of CIO n +19

$n = \text{CIO } 1500 + (25 \times \text{number of units})$

- Communications Port Abort Flag

The Communications Port Abort Flag is described below.

Unit/ Board	Port 1	Port 2
CS1 Board	CIO 190913	CIO 191913
CS1 Unit	Bit 13 of CIO N + 9	Bit 13 of CIO n+19

$n = \text{CIO } 1500 + (25 \times \text{number of units})$

# Chapter 7 Communications

## Ladder Program

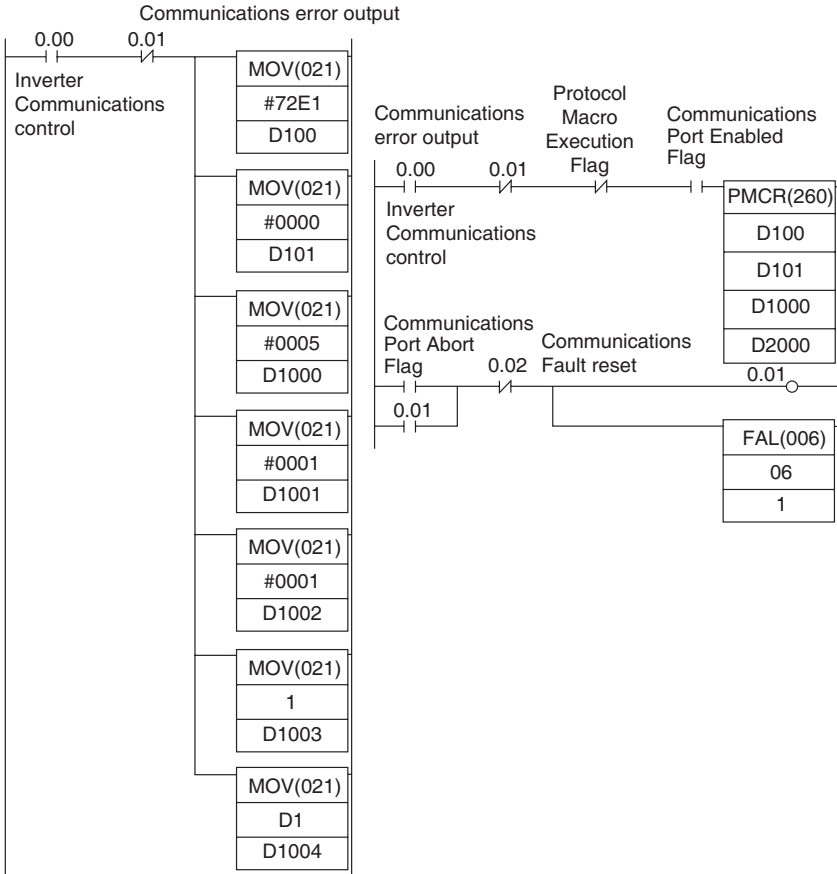

7-10 Communications Time

■ Communications Response Time

The communications response times for communications with an Inverter via the RS-422/485 port of an OMRON-made Communications Board are detailed below. Use this information as a reference when deciding the number of Slaves to be connected to one network, and when considering the timing of input and output signals.

Communications Time for One Message

A wide variety of programs for RS-422/485 communications can be created using the protocol macro function. The communications times will vary according to the contents of the program.

In general, the communications time for one message can be calculated using the following formula.

$$\text{Communications time} = [\text{Number of bytes in DSR message} \times 10 \text{ (See note 1.)} \times (1/\text{baud rate}) \times 1,000 \text{ (ms)}] + [\text{Number of bytes in response} \times 10 \times (1/\text{baud rate}) \times 1,000 \text{ (ms)}] + [24 \times (1/\text{baud rate}) \times 1,000 \text{ (ms)}] + \text{send wait time setting (ms)} + \text{protocol macro waiting time (See note 2.) (ms)}$$

The reason that the number of bytes in the DSR message and response is multiplied by 10 is because both the start bit and the stop bit require one bit each.

$$(1 \text{ byte} = 8 \text{ bits}) + (\text{start bit: } 1 \text{ bit}) + (\text{stop bit: } 1 \text{ bit}) = 10 \text{ bits}$$

With RS-422A/485 communications, set at least 20 ms as the protocol macro waiting time.

Calculation Example

The communications time required for one Slave in the protocol macro created in Creating a Project File, can be calculated according to the following formula. (Baud rate = 19,200 bps.)

$$\text{Communications time} = [(\text{DSR message to write data (13 bytes)} + \text{DSR message to read (8 bytes)}) \times 10 \times (1/19,200) \times 1,000 \text{ (ms)}] + [(\text{write response (8 bytes)} + \text{read response (7 bytes)}) \times 10 \times (1/19,200) \times 1,000 \text{ (ms)}] + [24 \times (1/19,200) \times 1,000 \text{ (ms)} \times 2] + [10 \text{ (ms)} \times 2] + [20 \text{ (ms)} \times 2] = 81.2 \text{ (ms)}$$

If there are N Slaves, the total communications time will be N × 81.2 ms. Consequently, the more Slaves that are used, the longer the communications time will be. If the number of Slaves is too high, it is possible that the detection time of 2 s for communications time-over will be exceeded. In this case, either disable the time-over detection function and use a different sequence to detect communications errors, or increase the number of Masters thereby decreasing the number of Slaves per Master.

I/O Response Time

The communications processing times for the Inverter are as follows.

- Inverter communications input scan: 8 ms
- Inverter communications output scan: 8 ms
- Internal processing time for the Inverter: Approx. 20 ms

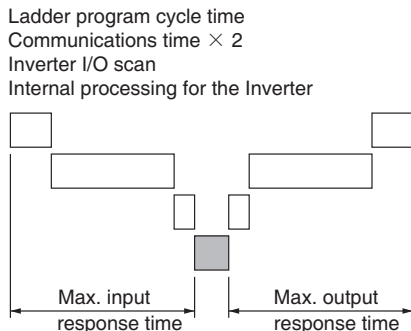



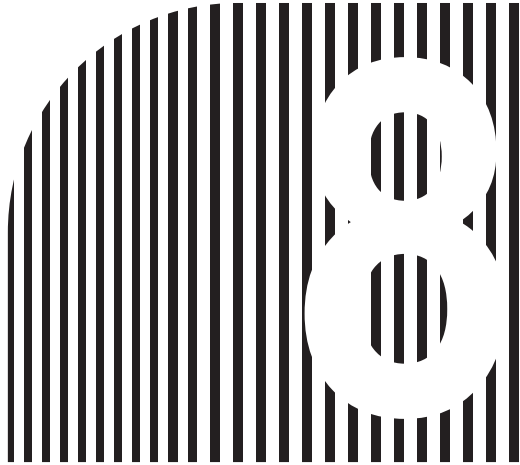

## Chapter 8

8

### ● Application ●

- 8-1 Protective and Diagnostic Functions
- 8-2 Troubleshooting
- 8-3 Maintenance and Inspection

# Chapter 8 Application

## 8-1 Protective and Diagnostic Functions

### 8-1-1 Fault Detection

The Inverter will detect the following faults if the Inverter or motor burns or the internal circuitry of the Inverter malfunctions. When the Inverter detects a fault, the fault code will be displayed on the Digital Operator, the fault contact output will operate, and the Inverter output will be shut off causing the motor to stop. (The stopping method can be selected for some faults, and the selected stopping method will be used with these faults.)

If a fault has occurred, refer to the following table to identify and correct the cause of the fault.

Use one of the following methods to reset the fault after restarting the Inverter. If the operation command is being input, however, the reset signal will be ignored. Therefore, be sure to reset the fault with the operation command turned off.

- Turn on the fault reset signal.

(Turn on the fault reset signal. A multi-function input (n4.05 to n4.08) must be set to 5 (Fault Reset).

Alternatively, set the bit of Fault Reset (bit No. 3 of register No. 2101 Hex) to 1 (ON) by communication.)

- Press the STOP/RESET Key on the Digital Operator.
- Turn the main circuit power supply off and then on again.



### ■ Fault Displays and Processing

Fault display	Fault name and meaning	Probable cause and remedy
<b>oc</b>	Overcurrent (OC) The Inverter output current is higher than 240% of the rated output current.	<ul style="list-style-type: none"> <li>• A short-circuit or ground fault has occurred and at the Inverter output.               <ul style="list-style-type: none"> <li>→ Check and correct the motor power cable.</li> </ul> </li> <li>• The V/f setting is incorrect.               <ul style="list-style-type: none"> <li>→ Initialize the V/f mode setting.</li> </ul> </li> <li>• The motor capacity is too large for the Inverter.               <ul style="list-style-type: none"> <li>→ Reduce the motor capacity to the maximum permissible motor capacity.</li> </ul> </li> <li>• The magnetic contactor on the output side of the Inverter has been opened and closed.               <ul style="list-style-type: none"> <li>→ Rearrange the sequence so that the magnetic contactor will not open or close while the Inverter has current output.</li> </ul> </li> <li>• The output circuit of the Inverter is damaged.               <ul style="list-style-type: none"> <li>→ Replace the Inverter.</li> </ul> </li> </ul>
<b>ocR</b>	Overcurrent in acceleration (OCA) The Inverter output current in acceleration is higher than 240% of the rated output current.	<ul style="list-style-type: none"> <li>• The acceleration time is too short.               <ul style="list-style-type: none"> <li>→ Set the acceleration time to maximum permissible value.</li> </ul> </li> <li>• The V/f setting is incorrect.               <ul style="list-style-type: none"> <li>→ Initialize the V/f mode setting.</li> </ul> </li> <li>• The motor capacity is too large for the Inverter.               <ul style="list-style-type: none"> <li>→ Reduce the motor capacity to the maximum permissible motor capacity.</li> </ul> </li> <li>• The load is too large for the Inverter.               <ul style="list-style-type: none"> <li>→ Reduce the load, correct the capacity of the Inverter.</li> </ul> </li> </ul>
<b>ocd</b>	Overcurrent in deceleration (OCD) The Inverter output current in deceleration is higher than 240% of the rated output current.	<ul style="list-style-type: none"> <li>• The deceleration time is too short.               <ul style="list-style-type: none"> <li>→ Set the deceleration time to maximum permissible value.</li> </ul> </li> <li>• The V/f setting is incorrect.               <ul style="list-style-type: none"> <li>→ Initialize the V/f mode setting.</li> </ul> </li> <li>• The motor capacity is too large for the Inverter.               <ul style="list-style-type: none"> <li>→ Reduce the motor capacity to the maximum permissible motor capacity.</li> </ul> </li> <li>• The load is too large for the Inverter.               <ul style="list-style-type: none"> <li>→ Reduce the load, correct the capacity of the Inverter.</li> </ul> </li> </ul>

Fault display	Fault name and meaning	Probable cause and remedy
OCN	Overcurrent in normal status (OCN) The Inverter output current in normal status is higher than 240% of the rated output current.	<ul style="list-style-type: none"> <li>• The V/f setting is incorrect. → Initialize the V/f mode setting.</li> <li>• The motor capacity is too large for the Inverter. → Reduce the motor capacity to the maximum permissible motor capacity.</li> <li>• The external load is too large for the Inverter. → Reduce the external load, correct the capacity of the Inverter.</li> </ul>
OV	Overvoltage (OV) The main circuit DC voltage has reached the overvoltage detection level 200-V models: 410 V DC min.; 400-V models: 820 V DC min.	<ul style="list-style-type: none"> <li>• Regeneration energy is too large (without operation option) → Prolong the deceleration when setting → Reduce n6.00 (stall prevention in deceleration operation level) by approximately 10 V (200-V models: 380V; 400-V models: 770V)</li> <li>• Power supply voltage is too high. → Set the power supply voltage within the rating.</li> </ul>
LV	Main circuit undervoltage (LV) The main circuit DC voltage has reached the undervoltage detection level 200-V models: 200 V DC min.; 400-V models: 400 V DC min.	<ul style="list-style-type: none"> <li>• Momentary power off has occurred. → Use momentary power off compensation function (n804: operation selection after recovery from momentary power off) → Change the power supply.</li> <li>• Power supply to the Inverter has phase loss or the power cable is disconnected. → Check for disconnections/loose screws/wiring broken and take necessary countermeasures.</li> <li>• Power supply voltage is incorrect. → Set the power supply voltage within the rating.</li> <li>• The internal circuit of the Inverter is damaged. → Replace the Inverter.</li> </ul>
OH1	Heat sink overheated (OH1) The temperature of the heat sink of the Inverter has reached 90 °C .	<ul style="list-style-type: none"> <li>• Cooling fan stopped (life expectancy has elapsed or faulty) → Replace the cooling fan (only for the inverters with cooling fans)</li> </ul>
OH2	PCB overheated (OH2) The temperature of the internal PCB has reached 90 °C .	<ul style="list-style-type: none"> <li>• Operation selection for the cooling fan is not correct → Set Cooling Fan Operation Selection (n308) to "0" (only for the inverters with cooling fans)</li> <li>• The load is too large for the Inverter. → Reduce the load. → Increase the capacity of the Inverter. → Prolong the acceleration/deceleration time.</li> <li>• The V/f setting is incorrect. → Initialize the V/f mode setting.</li> <li>• Ventilation is blocked → Change the ambient condition to meet the dimension requirements of the inverter</li> <li>• The ambient temperature is too high. → Ventilate the Inverter or install a cooling unit.</li> </ul>

## Chapter 8 Application

Fault display	Fault name and meaning	Probable cause and remedy
OL	<p>Inverter overloaded (OL)</p> <p>Work out the inverter's heat productivity according to the output current with electronic thermal method when the overload protection is activated (it will be detected when the output current is 150% of the rating and maintains for 1 minute)</p>	<ul style="list-style-type: none"> <li>• The acceleration/deceleration time is too short. → Set the acceleration/deceleration time to maximum permissible value.</li> <li>• The V/f setting is incorrect. → Initialize the V/f mode setting.</li> <li>• The load is too large for the Inverter. → Reduce the load</li> <li>• Inverter capacity insufficient → Increase the inverter capacity</li> </ul>
OL1	<p>Motor overload (OL1)</p> <p>When the motor overload protection is activated by electronic thermal (Based on motor rated current (n7.00), motor protection function selection (n6.06) and motor protection operation time (n6.07), calculate the motor's heat generation according to inverter's outputcurrent)</p>	<ul style="list-style-type: none"> <li>• Motor rated current (n7.00) setting error → Check the nameplate of the motor, set rated current in n7.00</li> <li>• Motor protection operation time (n6.07) setting is too short → Set default setting "60" to n6.07</li> <li>• Acceleration/deceleration time is too short → Prolong the acceleration/deceleration time</li> <li>• Maximum voltage frequency (n1.01) is too low → Check the nameplate of the motor, set the rated frequency in n1.01</li> <li>• The V/f setting is incorrect. → Initialize the V/f mode setting.</li> <li>• Drive multiple motors with one inverter → Disable motor overload detection, set thermal in each motor (Set n6.06 to "2", motor overload detection is disabled)</li> <li>• The load is too high → Reduce the load → Increase motor capacity</li> </ul>
OL2	<p>Overtorque detection (OL2)</p> <p>A current which exceeds the set value (n6.04: overtorque detection level) has been output for a time longer than the set time (n6.05: overtorque detection time) (detect the faults when n6.03 (overtorque detection function selection 1) set to "2" or "4")</p>	<ul style="list-style-type: none"> <li>• Mechanism fault (mechanism locked etc.) → Remove the cause of error</li> <li>• Parameter setting error → Set n6.04 (overtorque detecting level) and n6.05 (overtorque detecting time) to the value conforms to the mechanism (increase n6.04 or n6.05)</li> </ul>
GFF	<p>Ground (GFF)</p> <p>Ground current of the inverter output side exceeds 50% of the rated output current</p>	<ul style="list-style-type: none"> <li>• Cable broken → Check the resistor between UVW output and FG, replace the cable when short circuit</li> <li>• Cables and distributed capacitance of FG → Reduce carrier frequency when cable length exceeds 100 m</li> <li>• Motor burn out/insulation aged → Check the insulation resistor, replace the motor when short circuit</li> </ul>
PHL	<p>Input power supply has phase loss (PHL)</p> <p>Detect phase loss according to main circuit voltage variation</p>	<ul style="list-style-type: none"> <li>• Input power supply has phase loss → Check for main circuit wiring disconnection/wiring error, then correct it</li> <li>• Momentary power OFF occurs → Take countermeasures or disable input phase loss</li> <li>• Main circuit capacitor aging → Replace the inverter when no fault at the power supply side but problems take place frequently</li> </ul>

Fault display	Fault name and meaning	Probable cause and remedy
<b>EF</b>	External fault (EF) External fault has been input to multi-function inputs ("14" (external fault) is set to any item of multi-function input (n4.05 to n4.08))	<ul style="list-style-type: none"> <li>• External fault has been input → Remove the cause of external fault</li> <li>• Sequence fault → Correct the sequence of external faulty input (input time, the difference between contact a and contact b, etc.)</li> </ul>
<b>RErr</b>	Multi-function analog input signal fault (AERR) When using multi-function analog input in the way of current input (4 to 20 mA), if the current is smaller than the minimum current input (n4.15) of multi-function analog input A2, signal loss (n2.06) will be detected	<ul style="list-style-type: none"> <li>• Cable disconnected → Check for cable disconnection and correct it</li> <li>• Input signal fault → Check if there are problems on host side or in the detector and then correct it</li> <li>• Different from the minimum current of input signal → Set the minimum current input (n4.15) of frequency command input terminal A1 to a value which conforms to input signal → Set frequency command input loss detection option (n2.06) to "0" to disable it</li> </ul>
<b>bb</b>	External base pole blockade (BB) External base pole blockade instruction has been input ("9" (external base pole blockade) is set to any item of multi-function input selection (n4.05 to n4.08), the input performs an operation) ※ The inverter coast to a stop	<ul style="list-style-type: none"> <li>• External base pole blockade command has been input → Remove the cause of external base pole blockade</li> <li>• Sequence fault → Correct the external base pole blockade command input sequence (input time, the difference between contact a and contact b, etc.)</li> </ul>
<b>CF 1.0</b>	EEPROM write fault (CF1.0) EEPROM inside the inverter is faulty	<ul style="list-style-type: none"> <li>• Internal circuit fault → If RESET disabled when EEPROM overload, recycle the power supply. If the CF2.0 code returns, the way are: 1. Press the MODE key,  and into the normal display.</li> <li>2. Set parameter n0.02=9(50Hz initialize) or 10(60Hz initialize) refer to the page 3-4.</li> <li>3. Press the RESET key </li> <li>4. If the CF2.0 code still exists, replace the inverter</li> <li>5. Set the normal parameters if the CF2.0 code disappear</li> <li>6. Recycle the power supply, if the CF2.0 code disappear the continue to use, if not replace the inverter.</li> </ul>
<b>CF 2.0</b>	EEPROM read fault (CF2.0) EEPROM inside the inverter is faulty	
<b>CF 3.0</b>	U-phase circuit fault (CF3.0) Inverter U phase output circuit is faulty	<ul style="list-style-type: none"> <li>• Internal circuit fault → Check for errors and recycle the power → If the problem still exists, replace the inverter</li> </ul>
<b>CF 3.1</b>	V-phase circuit fault (CF3.1) Inverter V phase output circuit is faulty	
<b>CF 3.2</b>	W-phase circuit fault (CF3.2) Inverter W phase output circuit is faulty	
<b>CF 3.3</b>	Voltage control circuit fault (CF3.3) The circuit which controls voltage is faulty	
<b>CF 3.4</b>	Temperature detector 1 fault (CF3.4) Temperature detection circuit 1 is faulty	
<b>CF 3.5</b>	Temperature detector 2 fault (CF3.5) Temperature detection circuit 2 is faulty	
<b>HPF 1</b>	Current control circuit fault (HPF1) Current control circuit is faulty	
<b>HPF 2</b>	Overvoltage detection circuit fault (HPF2) Overvoltage detection circuit is faulty	
<b>HPF 3</b>	Ground detection circuit fault (HPF3) Ground detection circuit is faulty	
<b>HPF 4</b>	Overcurrent detection circuit fault (HPF4) Overcurrent detection circuit is faulty	

## Chapter 8 Application

### 8-1-2 Warning Detection

A warning is to continue the operation of inverter/motor when the faulty output is not in operation, after the cause is removed, system will be recovered automatically.

The Digital Operator displays the detail of the error.

If a warning occurs, take appropriate countermeasures according to the table below.

※ Set "Stop after detection" in the parameter, the output will stop although there is a warning detection.

#### ■ Warning Displays and Processing

Fault display	Warning name and Meaning	Probable cause and remedy
<b>OL2</b>	<b>Overtorque detection (OL2)</b> A current (n6.04: overtorque detection level) exceeds the set value has been output for a time longer than the set time (n6.05: overtorque detection time) (warning detection when n6.03 (overtorque detection function selection 1) is set to "1" or "3")	<ul style="list-style-type: none"><li>• Mechanism fault (mechanism locked etc.) → Remove the cause of the fault</li><li>• Parameter setting error → Set n6.04 (overtorque detection level) and n6.05 (over torque detection time) to a value which conforms to the mechanism (increase the set value of n6.04 or n6.05)</li></ul>
<b>CE01</b>	<b>FUNCTION code error (CE01)</b> The FUNCTION code sent in RS485 communication is set to a value other than 03Hex, 10Hex.	<ul style="list-style-type: none"><li>• FUNCTION code difference → Check the FUNCTION code in RS485 communication program of the host, and then correct it</li></ul>
<b>CE02</b>	<b>Register NO. error (CE02)</b> A register No. other than the specified one is used	<ul style="list-style-type: none"><li>• A register which has not been logged was accepted → Check the register No. in RS485 communication program of the host and then correct it</li></ul>
<b>CE03</b>	<b>Data error (CE03)</b> Faulty data was sent in RS485 communication	<ul style="list-style-type: none"><li>• The bytes sent does not match the added data</li><li>• Added data is longer than 20 (20 × 16 bit)</li><li>• Added data exceed the parameter upper/lower limit → Check the data of host RS485 communication program and then correct it</li></ul>
<b>CE04</b>	<b>Slave execution error (CE04)</b> Slave can not execute the request sent by RS485 communication	<ul style="list-style-type: none"><li>• A parameter which can not be written in operation is written → Check Host RS485 communication program send time and correct it</li></ul>
<b>CE06</b>	<b>Slave in execution (CE06)</b> The slave can not accept a new request when it is executing another request	<ul style="list-style-type: none"><li>• A new request is sent when another request is in process → Check the sending time of RS485 communication program and then correct it → Check RS485 communication send wait time (n9.04) to see if it is too long, if it is, correct it</li></ul>

Fault display	Warning name and Meaning	Probable cause and remedy
CE 10	Communication time out (CE10) RS485 communication timeout detection time (n9.05) is exceeded, unable to establish a normal communication	<ul style="list-style-type: none"> <li>• Communication wiring is disconnected/shortened/grounded               <ul style="list-style-type: none"> <li>→ Check the wiring status and then correct it</li> </ul> </li> <li>• Terminator is not connected               <ul style="list-style-type: none"> <li>→ Check if both ends of RS485 communication have been connected to terminators, and then correct it</li> </ul> </li> <li>• Fault caused by noise               <ul style="list-style-type: none"> <li>→ Pull out the communication line from the conduit</li> <li>→ Ground at the host side with shielded twisted pair cable</li> </ul> </li> <li>• Communication time is too long               <ul style="list-style-type: none"> <li>→ Modify the communication time of host RS485 communication program, allow it to communicate at least once during RS485 communication timeout detection time (n9.05)</li> <li>→ Set RS485 communication timeout detection time (n9.05) to an appropriate value</li> <li>→ Set RS485 communication timeout detection time (n9.05) to "0.0" to disable it</li> </ul> </li> <li>※ When you set communication timeout detection time to disable or very long, you must take proper countermeasures to keep safety when communication is faulty.</li> <li>• Communication circuit is faulty               <ul style="list-style-type: none"> <li>→ Replace the inverter</li> </ul> </li> </ul>

### 8-2 Warning Analyse

Due to parameter setting errors, faulty wiring, and so on, the Inverter and motor may not operate as expected when the system is started up.

If that should occur, use this section as a reference and apply the appropriate measures.

Refer to 8-1 Protective and Diagnostic Functions, if the contents of the fault are displayed.

---

1

#### Parameters Fail Set

■ The display does not change when the Increment or Decrement Key is pressed.

- Parameter write-prohibit is input.

Set n0.02 (Parameter Write Disable/Parameter Initialize) to "1", the parameters other than n0.02 can not be set.

Set n0.02 to "0" to set the parameter.

- "Parameter Write Disable" has been input to Multi-function Input.

Set Multi-function Input (n4.05 to n4.08) to "17" (Parameter Write Disable), parameter can not be set by corresponding input.

Set the parameter after turning OFF the Parameter Write Disable.

- The inverter is in operation.

When the inverter is in operation, you can only change the parameters which can be written in operation. Refer to Parameter Overview to check if it can be written in operation.

For those parameters can not be set in operation, stop the inverter and try again.

■ The Digital Operator does not display anything.

- Power supply disconnected

Check the inverter to see if the power has been supplied, or measure the voltage at inverter's power supply terminal with a universal electric meter. If the voltage is too low, check the wiring and sequence, then correct any error.

- Digital Operator or Inverter is broken

Digital Operator does not display anything when it's broken, or the inverter is broken. Reset the power supply, if the problem still exists, change the broken part.

2

#### Motor Fails to Operate

■ The motor does not operate with input through the control circuit terminals even though the frequency reference is correct.

- The operation method setting is incorrect.

If parameter n2.01 for operation mode selection is not set to 1 or 2 to enable the control circuit terminals block, the RUN command cannot be executed through the control circuit terminals.

Check and correct the setting in n2.01.

- Both Forward rotation command and Reverse rotation command are set to ON.

If both Forward/Reverse rotation command are set to ON, the Inverter will not operate.

Check and correct the setting. Do not set Forward rotation command and Reverse rotation command to ON at the same time.

- Input in 2-wire sequence while 3-wire sequence is in effect and vice-versa.

The Inverter will operate in 3-wire sequence according to the RUN, stop, and forward/reverse commands if n4.04 for multi-function input 1/2 is set to 2. At that time, the Inverter will not operate if input in 2-wire sequence is ON.

On the other hand, the Inverter in 2-wire sequence will only rotate in the reverse direction if input in 3-wire sequence is ON.

Check and correct the setting in n04.04 or change the input method of the RUN command.

- The frequency reference is too low.  
If the frequency reference is set below the minimum output frequency set in n1.05, the Inverter will not operate. Raise the frequency reference to at least the minimum output frequency.
  - Switching RUN command by using multi-function input  
To set “18 (operation command switch: control terminals)”, “19 (operation command switch: operator)” and “20 (operation command switch: communication)” in multi-function input (n4.05-n4.08) to switch operation command temporarily. The commands will be performed in the priority order as below:  

$$n2.01 \text{ (Selecting operation command)} < 20 \text{ (operation command switch: communication)} < 19 \text{ (operation command switch: operator)} < 18 \text{ (operation command switch: control terminals)}$$
  - The input wiring of the control circuit terminals of the Inverter is incorrect.  
The Inverter cannot check the input signal if the input line of the control circuit terminals is incorrectly wired. The default setting for Inverter input is to NPN sequence input, which can be changed to PNP sequence input. Refer to 2-2-2 Terminal Block and check that the SW1 settings conform with the actual wiring.
- The motor does not operate with input through the control circuit terminals. (The frequency reference is zero or different from the set value.)
- The frequency reference setting is incorrect.  
The analog input of frequency references is ignored with the Digital Operator selected. The digital input of frequency references is ignored unless the Digital Operator is selected.  
Check that the setting in n2.00 for frequency reference selection coincides with the actual method of giving frequency commands.
  - Switching frequency command by using multi-function input  
Set "22 (the secondary frequency command n2.09)", "1-3 (multi-step speed command)", "8 (Jog command)" in the multi-function input (n4.05 to n4.08) to switch the frequency command. The commands will be performed in the priority order as below:  

$$n2.00 \text{ (Selecting frequency command)} < 22 \text{ (the secondary frequency command n2.09)} < 1-3 \text{ (multi-step speed command)}$$
  - The analog input(frequency command input A1 terminal) setting is incorrect.  
Check that the analog input(frequency command input A1 terminal) setting in n4.11 to 4.18 are set according to the actual analog input characteristics.
- The motor stops during acceleration or when a load is connected.
- The load may be too big.  
The 3G3JZ has a stall prevention function and automatic torque boost function, but the motor responsiveness limit may be exceeded if acceleration is too rapid or if the load is too big.  
Lengthen the acceleration time or reduce the load. Also consider increasing the motor capacity.
- The motor only rotates in one direction.
- Reverse rotation-prohibit is selected.  
If n2.04 for reverse rotation-prohibit selection is set to 1 (reverse run prohibited) or 2 (forward run prohibited), the Inverter will only rotates in one direction.  
(If the reverse rotation-prohibit is selected, the Inverter will not accept reverse-rotation commands and if the forward rotation-prohibit is selected, the Inverter will not accept forward-rotation commands).  
To use both forward and reverse rotation, set to 0 (Reverse rotation-enable).

## Chapter 8 Application

---

3

### Motor Rotates in the Wrong Direction

- The output wiring of the motor is faulty.  
When the U, V, and W terminals of the Inverter are properly connected to the U, V and W terminals of the motor, the motor operates in a forward direction when a forward rotation command is executed.  
The motor direction depends on the maker and the motor type. Therefore, be sure to check the specifications.  
Switching two wires among the U, V, and W will reverse the direction of rotation.
- Reverse rotation-prohibit is selected.  
If n2.04 for reverse rotation-prohibit selection is set to 1 (reverse run prohibited) or 2 (forward run prohibited), the Inverter will only rotate in one direction.  
Therefore, if the reverse rotation-prohibit is selected, the Inverter will not accept reverse-rotation commands and if the forward rotation-prohibit is selected, the Inverter will not accept forward-rotation commands.)  
To use both forward and reverse rotation, set to 0 (Reverse rotation-enable).

4

### Motor Outputs No Torque or Acceleration is Slow

- The stall prevention level during running is too low.  
If the value in n6.01 for stall prevention level during acceleration is too slow, the acceleration time will be too long.  
Check to be sure that the set value is suitable.
- The stall prevention level during acceleration is too low.  
If the value in n6.02 for stall prevention level during operation is too low, the speed will drop before torque output is turned ON.  
Check to be sure that the set value is suitable.

7

### If the Vertical-axis Load Drops When Brake Is Applied

- There is a fault in the sequence.  
Because of the output status of inverters do not in concordance with the Brake operation, cause the load drops.  
Set "21 (External brake output)" in multi-function output (n3.00) to operate the brake.  
By setting the parameters n3.11(External brake open frequency) and n3.12 (External brake operation frequency) to make sure that the frequency will not drop.
- The wrong brake is being used.  
Use the main brake rather than the holding brake.

8

### Motor Burns

- The load is too big.  
If the load of the motor is too big and the motor is used with the effective torque exceeding the rated torque of the motor, the motor will burn out. For example, the rated torque of the motor and capacity may be limited to eight hours of use if the inscription on the motor states that the motor is rated for eight hours.  
If the 8-hour rated torque is used for normal operation, it may cause the motor to burn out.  
Reduce the load amount by either reducing the load or lengthening the acceleration/deceleration time.  
Also consider increasing the motor capacity.
- The ambient temperature is too high.  
The rating of the motor is determined within a particular ambient operating temperature range. The motor will burn out if it runs continuously at the rated torque in an environment in which the maximum ambient operating temperature is exceeded.  
Lower the ambient temperature of the motor to within the acceptable ambient operating temperature range.

- The withstand voltage between the phases of the motor is insufficient.

When the motor is connected to the output of the Inverter, a surge will be generated between the switching of the Inverter and the coil of the motor.

Normally, the maximum surge voltage is approximately three times the input power supply voltage of the Inverter (i.e., approximately 600 V for 200-V models, and approximately 1,200 V for 400-V models).

Therefore, the dielectric strength of the motor to be used must be higher than the maximum surge voltage.

In particular, use a dedicated motor for 400-V Inverters.

9

### Controller or AM Radio Receives Noise when Inverter is Started

- Noise derives from Inverter switching. Take the following actions to prevent noise.

- Lower the carrier frequency of the Inverter in n2.03.

The number of internal switching times is reduced, so noise can be reduced to some extent.

- Install an Input Noise Filter.

Install an Input Noise Filter on the power input area of the Inverter.

- Install an Output Noise Filter.

Install an Output Noise Filter on the output area of the Inverter.

- Use metal tubing.

Electric waves can be shielded by metal (iron). Therefore, enclose the Inverter with a metal tube.

10

### Ground Fault Interrupter is Actuated when Inverter is Started

- Leakage current flows through the Inverter.

The Inverter performs internal switching. Therefore, a leakage current flows through the Inverter. This leakage current may actuate the ground fault interrupter, shutting the power off.

Use a ground fault interrupter with a high leakage-current detection value (sensitivity amperage of 200 mA or more, operating time of 0.1 s or more) or one with high-frequency countermeasures for Inverter use.

Reducing the carrier frequency value in n2.03 is also effective.

In addition, remember that a leakage current increases in proportion to the cable length. Normally, approximately 5 mA of leakage current is generated for each meter of cable.

11

### Mechanical Vibration

- Mechanical system makes unusual noise.

- Resonance between the characteristic frequency of the mechanical system and the carrier frequency.

There may be resonance between the characteristic frequency of the mechanical system and the carrier frequency. If the motor is running with no problems and the machinery system is vibrating with a high-pitched whine, it may indicate that this is occurring. To prevent this type of resonance, adjust the carrier frequency value in n2.03.

- Resonance between the characteristic frequency of a machine and the output frequency of the Inverter.

There may be resonance between the characteristic frequency of a machine and the output frequency of the Inverter. To prevent this from occurring, use the frequency jump function with the constants set in n8.09 through n8.12 to change the output frequency or install vibration-proof rubber on the motor base to prevent the resonance of the mechanical system.

- Motor vibrates excessively and does not rotate normally.

- Motor Phase Interruption

If one or two of the three phases of the motor are open, the motor will vibrate excessively and will not rotate.

Check that the motor is wired correctly without any disconnection. The same phenomenon will occur if the output transistor of the Inverter is open and damaged. Check the balance of the Inverter's output voltage as well.

## Chapter 8 Application

### 13 Motor Rotates after Output of Inverter is Turned OFF

#### • Insufficient DC Injection Braking Control

If the motor continues operating at low speed, without completely stopping, and after a deceleration stop has been executed, it means that the DC injection braking is not decelerating enough.

In such cases, adjust the DC control as described below.

-Increase the parameter in n8.00 for DC injection braking current.

-Increase the parameter in n8.02 for DC injection braking-to-stop time.

-Increase the parameter in n8.03 for DC injection braking-to-stop initial frequency, adjust to the appropriate frequency.

### 14 Detects OV (Over voltage) and Stalls when Motor Starts

#### • Insufficient DC Injection Braking Control at Startup

Generation of OV and stalling can occur if the motor is turning when it is started.

This can be prevented by slowing the rotation of the motor by DC injection braking before starting the motor.

Increase the parameter in n8.01 for startup DC injection braking time.

### 15 Output Frequency Does Not Reach Frequency Reference

#### • The frequency reference is within the jump frequency range.

If the jump function is used, the output frequency stays within the jump frequency range.

Make sure that the jump width settings in n8.09 through n8.12 for jump frequencies 1 through 2 are appropriate.

#### • Exceeds the upper-limit frequency.

The upper-limit frequency can be obtained from the following formula.

Maximum frequency in n1.00  $\times$  frequency reference upper limit in n1.07/100.

Make sure that the parameters in n1.00 and n1.07 are correct.

### 16 Motor Rotates Momentarily When Control Device Power is Turned OFF

#### • Malfunction Due to Unwanted Current Path



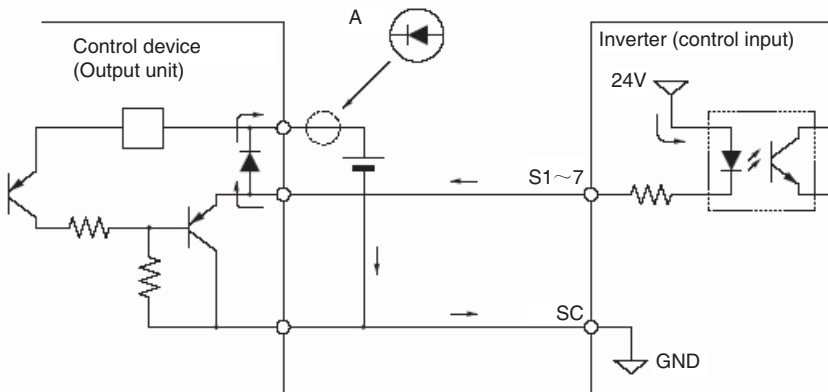

Inverter inputs may remain ON due to an unwanted current path for the controller outputs.

With the wiring shown in the following table, if the controller output power supply is less than 24 V DC or if the power is OFF, the current indicated by the arrow will flow and the Inverter inputs will operate.

If that occurs, insert a diode as shown in the diagram at point A.



### 8-3 Maintenance and Inspection

 <b>WARNING</b>	
Do not open terminal case when power is being supplied or power has just been turned OFF for less than 10 minutes. Doing so may occasionally result in minor injury due to electric shock.	
Do not touch the radiating fan when power is being supplied or power has just been turned OFF for a short period. Doing so may occasionally result in scald due to high temperature.	
Do not disassemble and modify the inverter. Doing so may occasionally result in serious injury due to electric shock.	

#### Safety Precautions

1. Ensure safety when performing maintenance, inspection and part replacement.

#### Precautions

- Operation command selection (n2.01) is set to control circuit terminal, operation selection after power supply putting in/operation command switching (n2.05) is set to enable, turn ON the power when there are operation signals.
- Multi-function input (n4.05 to n4.08) is set to operation command switch, operation selection after power supply putting in/operation command switching (n2.05) is set to enable, switch to other operation commands when there are some operation signals.
- Fault retry times (n8.15) is set to enable, auto resetting from faulty stop.
- Verify the signal when power is being supplied, apply an incorrect voltage to control input terminal.

#### ■ Warranty and Limitations of Liability

##### • WARRANTY TERM

OMRON's exclusive warranty is that the products are free from defects in materials and workmanship for a period of one year from date of sale by OMRON, or 18 months from shipping, which is shorter.

#### ■ Daily Inspection

Check the following items with the system in operation.

- The motor should not be vibrating or making unusual noises.
- There should be no abnormal heat generation.
- The ambient temperature should not be too high.
- The output current value shown on the monitor displays should not be higher than normal.
- The cooling fan on the bottom of the Inverter should be operating normally.

## Chapter 8 Application

### ■ Periodic Inspection

Check the following items during periodic maintenance.

Always turn OFF the power supply before beginning inspection. Turn OFF the main circuit power supply, wait for the time indicated on the front cover, and make sure the CHARGE indicator light has gone out, and then perform maintenance and inspection. Be sure not to touch terminals right after the power has been turned off. Doing so can result in electric shock.

#### Periodic Inspections

Item	Inspection	Corrective Procedure
External terminals, mounting bolts, connectors, etc.	Are all screws and bolts tight?	Tighten loose screws and bolts firmly.
	Are connectors tight?	Reconnect the loose connectors.
Heatsinks	Are the fins dirty or dusty?	Clean off any dirt and dust with an air gun using dry air at a pressure of $39.2 \times 10^4$ to $58.8 \times 10^4$ Pa (4 to 6 kg · m <sup>2</sup> ).
Cooling fan	Is there any abnormal noise or vibration or has the total operating time exceeded 20,000 hours?	Replace the cooling fan.
Power elements	Is there any conductive dirt or oil mist on the elements?	Clean off any dirt and dust with an air gun using dry air at a pressure of $39.2 \times 10^4$ to $58.8 \times 10^4$ Pa (4 to 6 kg · cm <sup>2</sup> ).
Smoothing capacitor	Are there any irregularities, such as discoloration or odor?	Replace the capacitor or Inverter.

### ■ Periodic Maintenance of Parts

The Inverter is configured of many parts, and these parts must be operating properly in order to make full use of the Inverter functions.

Among the electronic components, there are some that require maintenance depending on their usage conditions. In order to keep the Inverter operating normally over a long period of time, it is necessary to perform period inspections and replace parts according to their service life. (Refer to "commands for Periodic Inspection of General Purpose Inverter" (JEMA))

Periodic inspection standards vary depending the Inverter's installation environment and usage conditions. The Inverter's maintenance periods are noted below. Keep them as reference.

#### Part Replacement Guidelines

Part	Standard Replacement Period*	Replacement Method
Cooling fan	2 to 3 years	Replace with new part.
Smoothing capacitor	5 years	Replace with new part. (Determine need by inspection.)
Breaker relays	— —	Determine need by inspection.
Fuses	10 years	Replace with new part.

\* The standard replacement period is based on the following usage conditions:

- Ambient temperature: Yearly average of 30 °C
- Load factor: 80% max.
- Operating rate: 12 hours max. per day

## ■ Replacement of Cooling Fan

If the FAN fault is displayed or the cooling fan needs replacement, take the following steps to replace it.

- ① Press the left and right sides of the fan cover located on the lower part of the radiation fin in the arrow 1 directions. Then lift the bottom of the Fan in the arrow 2 direction to remove the fan as shown in the following illustration. Disconnect the wire from the electrical inlet on the bottom of the plastic casing.
- ② Remove the Fan from the fan cover.
- ③ Slide the protective tube and remove the internal connector.
- ④ Remove the Fan from the fan cover. Mount the new Fan on the fan cover.
- ⑤ Do the same above reverse to mount the fan cover.

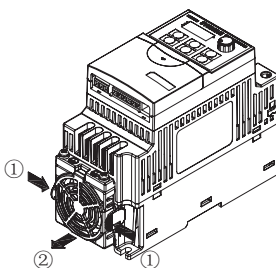



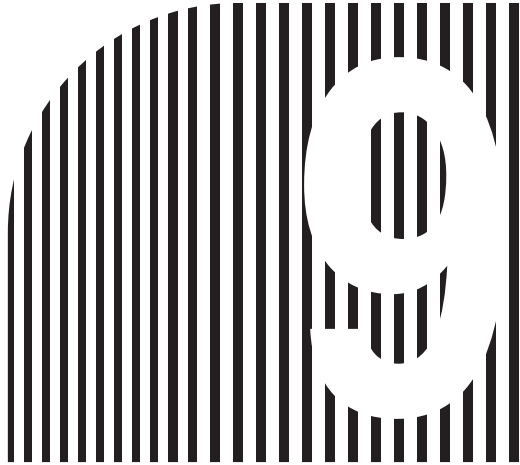

## Chapter 9

### ● Specifications ●

#### 9-1 Inverter Specifications

# Chapter 9 Specifications

## 9-1 Inverter Specifications

### ■ 200V Inverters

Single-phase 200V	3G3JZ-AB □□□		002	004	007	015	022
	Max. applicable motor power(KW)		0.2	0.4	0.75	1.5	2.2
	Output	Rated output capacity(KVA)	0.6	1.0	1.6	2.9	4.2
		Rated output current (A)	1.6	2.5	4.2	7.5	11.0
		Max. output voltage (V)	3-phase 200 ~ 240VAC (Corresponds to input voltage)				
		Output frequency range (Hz)	0.1 ~ 600Hz				
		Carrier frequency (kHz)	2-15				
	Supply	Input current (A)	4.9	6.5	9.7	15.7	24
		Rated voltage, frequency	Single-phase power supply 200 ~ 240V, 50/60Hz				
		Allowable input voltage fluctuation range	± 10%				
		Allowable power supply frequency fluctuation	± 5%				
	Cool down method		Naturally wind cooling			Forced cool down	
Weight (kg)		1.1	1.1	1.1	1.9	1.9	

3-phase 200V	3G3JZ-A2 □□□		002	004	007	015	022	037
	Max. applicable motor power (KW)		0.2	0.4	0.75	1.5	2.2	3.7
	Output	Rated output capacity(KVA)	0.6	1.0	1.6	2.9	4.2	6.5
		Rated output current (A)	1.6	2.5	4.2	7.5	11.0	17
		Max. output voltage (V)	3-phase 200 ~ 240VAC (Corresponds to input voltage)					
		Output frequency range(Hz)	0.1 ~ 600Hz					
		Carrier frequency (kHz)	2-15					
	Supply	Input current (A)	1.9	2.7	5.1	9	15	20.6
		Rated voltage, frequency	3-phase power supply 200 ~ 240V, 50/60Hz					
		Allowable input voltage fluctuation range	± 10%					
		Allowable power supply frequency fluctuation	± 5%					
	Cool down method		Naturally wind cooling			Forced cool down		
Weight (kg)		1.1	1.1	1.1	1.2	1.9	1.9	

### ■ 400V Inverters

3-phase 400V	3G3JZ-A4 □□□		004	007	015	022	037
	Max. applicable motor power (KW)		0.4	0.75	1.5	2.2	3.7
	Output	Rated output capacity (KVA)	1.2	2.0	3.3	4.4	6.8
		Rated output current (A)	1.5	2.5	4.2	5.5	8.2
		Max. output voltage (V)	3-phase 380 ~ 480VAC (Corresponds to input voltage)				
		Output frequency range (Hz)	0.1 ~ 600Hz				
		Carrier frequency (kHz)	2-15				
	Power supply	Input current (A)	1.9	3.2	4.3	7.1	11.2
		Rated voltage, frequency	3-phase power supply 380 ~ 480V, 50/60Hz				
		Allowable input voltage fluctuation range	± 10%				
		Allowable power supply frequency fluctuation	± 5%				
	Cool down method		Naturally wind cooling		Forced cool down		
	Weight (kg)		1.2	1.2	1.2	1.9	1.9

### ■ General Specifications

Control characteristic	Control method	Sine wave PWM method
	Frequency setting resolution	Digital command: 0.01Hz (100Hz max.), 0.1Hz (100Hz min.)
	Output frequency resolution	0.01Hz (calculate resolution)
	Overload withstanding	150% of rated output current 1 minute
	External frequency setting signal	Switch: 0 to +10VDC (47kΩ)/4 to 20mA(250Ω)/frequency adjuster/Multi-step speed reference (7 step speed)
	acceleration/deceleration time	0.00 ~ 600.0 seconds (acceleration/deceleration time set separately)
	Braking torque	continuous approximate 20%
	Voltage/frequency characteristic	any V/f form setting
Protect function	Motor protect	Protect with electronic thermal function
	Momentary overcurrent protect	Stop when rated output current is more than 240%
	Overload protect	Stop when it keeps at 150% of rated output current for 1 minute
	Overvoltage protect	Stop at 410 VDC for 200 V model/820 VDC for 400 V model
	Undervoltage protect	Main circuit DC voltage: stop below 200 VDC for 200 V model, 400 VDC for 400 V model
	Momentary power OFF	Immediate stop (stop over 15 ms) or keep running till the time setting (0.1 to 5.0) elapses
	Heatsink overheat	Check when the heatsink temperature is 90 °C
	Ground protect	Protect when inverter's rated output current is approximate 50%
Environment	Location of use	Indoor (no corrosive gas or dust)
	Ambient Operating Temperature	In-panel mounting type:-10 °C to +50 °C (close mounting: -10 °C to +40 °C )
	Ambient operating humidity	90%RH max. (without condensation)
	Storage temperature	-20 °C to +60 °C
	Elev.	1000m max.
	Insulation resistance	5MΩ min. (do not perform an insulation test or voltage withstand test)
Shock resistance	frequency less than 10 to 20 Hz 9.8 m/s <sup>2</sup> (1G) max., 20 to 50 Hz 5.9 m/s <sup>2</sup> (0.6G) max.	
Enclosure	In-panel mounting type (IP20)	
Conformity	CE Directive conformed	





## Chapter 10

- List of Parameters ●

# Chapter 10 List of Parameters

In order to make easier settings of 3G3JZ parameters, parameters are divided into 11 groups based on the functions and are described below.

Parameter No.	Name	Description	Reference page
n0	Environment settings	Select the environment group, such as control mode selection. Parameter write-prohibit and change of monitor range of parameters are also included in this function group.	10-2
n1	V/f mode and acceleration/ deceleration time settings	Set the basic characteristics for the inverter. Set V/f mode, acceleration/deceleration conditions.	10-4
n2	Operation mode settings	Set the operation mode for the inverter. Set the input mode by selecting frequency command or operation command.	10-5
n3	Output function settings	Set the control circuit output functions for the inverter. Select multi-function output or analog output and adjust the set value.	10-8
n4	Input function settings	Set the control circuit input functions for the inverter. Select multi-function input or analog input and adjust the set value.	10-10
n5	Multi-step speed frequency command settings	Set the frequency command for multi-step speed operation. Set multi-step speed reference in the multi-function input, and change over operations at 7-step frequency command as the maximum. Set the current frequency command.	10-14
n6	Protection function settings	Set and adjust the protection function for the motor. Set and adjust the motor overheating protection function and stall prevention function. Also confirm the error history record.	10-14
n7	Motor parameter settings	Set the motor-related parameters. This parameter is very important for vector control, and the motor automatic adjustment is also included in this function group. It is required to set when thermistor is directly installed on the motor for overheating protection.	10-17
n8	Other function settings	Set other functions for inverter. DC braking function, operations after instant loss of power supply, leaping frequency function, energy saving function, etc. are integrated.	10-18
n9	RS485 communication settings	Set the RS485 communications for the inverter. It is required to set when controlling the inverter with PLC via RS485 communication link.	10-19

## ● n0: Environment settings

Parameter No.	Register No. (Hex)	Name	Description				Setting range	Unit of setting	Default setting	Changes during operation	Reference page
			Value	Power supply specification/capacity	Value	Power supply specification/capacity					
n0.00	0000	Inverter capacity being monitored ※ Only for reference	Display the power supply specifications and capacity for the inverter. Applicable specification/capacity for each inverter is as follows.				—	1	—	—	3-7
			0	Single-phase/3-phase 200VAC/0.2kW	9	3-phase 400VAC/2.2kW					
			1	Not used	10	Single-phase/3-phase 200 VAC/3.7 kW					
			2	Single-phase/3-phase 200VAC/0.4 kW	11	3-phase 400 VAC/3.7kW					
			3	3-phase 400VAC/0.4kW							
			4	Single-phase/3-phase 200 VAC/0.75 kW							
			5	3-phase 400VAC/0.75kW							
			6	Single-phase/3-phase 200 VAC/1.5 kW							
			7	3-phase 400VAC/1.5kW							
			8	Single-phase/3-phase 200 VAC/2.2 kW							
n0.02	0002	Parameter write-prohibit selection/parameter initialization	Prohibit parameters to be written and reset parameters to default values. 0: All parameters can be set and displayed 1: Parameter n0.02 can be set only, and other parameters can be displayed. 8: Operation button unable 9: Initializes at the maximum frequency of 50Hz. 10: Initializes at the maximum frequency of 60Hz				0 ~ 10	1	0	×	5-1
n0.03	0003	Items being monitored selection when power ON	Set the items desired to display immediately when power ON. 0: Frequency command 1: Output frequency 2: Output current 3: Items being monitored set in n0.04 4: FWD (forward rotation)/REV (reverse rotation)				0 ~ 4	1	0	○	3-6

## Chapter 10 List of Parameters

Parameter No.	Register No. (Hex)	Name	Description	Setting range	Unit of setting	Default setting	Changes during operation	Reference page																												
n0.04	0004	Selecting items being monitored	Select one of the five items displayed via the operator to change. Set the items desired to be displayed.	0 ~ 11	1	4	○	3-5																												
			<table border="1"> <thead> <tr> <th>Set value</th> <th>Item being monitored</th> <th>Set value</th> <th>Power supply specifications/capacity</th> </tr> </thead> <tbody> <tr> <td>0</td> <td>Monitoring set by user</td> <td>6</td> <td>Power factor</td> </tr> <tr> <td>1</td> <td>(Not used)</td> <td>7</td> <td>Output power</td> </tr> <tr> <td>2</td> <td>(Not used)</td> <td>8</td> <td>(Not used)</td> </tr> <tr> <td>3</td> <td>DC voltage of the main circuit</td> <td>9</td> <td>Frequency command (voltage) Input terminal A1 voltage</td> </tr> <tr> <td>4</td> <td>Output voltage command</td> <td>10</td> <td>Frequency command (current) Input terminal A1 current</td> </tr> <tr> <td>5</td> <td>(Not used)</td> <td>11</td> <td>IGBT temperature</td> </tr> </tbody> </table>						Set value	Item being monitored	Set value	Power supply specifications/capacity	0	Monitoring set by user	6	Power factor	1	(Not used)	7	Output power	2	(Not used)	8	(Not used)	3	DC voltage of the main circuit	9	Frequency command (voltage) Input terminal A1 voltage	4	Output voltage command	10	Frequency command (current) Input terminal A1 current	5	(Not used)	11	IGBT temperature
			Set value						Item being monitored	Set value	Power supply specifications/capacity																									
			0						Monitoring set by user	6	Power factor																									
			1						(Not used)	7	Output power																									
			2						(Not used)	8	(Not used)																									
			3						DC voltage of the main circuit	9	Frequency command (voltage) Input terminal A1 voltage																									
			4						Output voltage command	10	Frequency command (current) Input terminal A1 current																									
5	(Not used)	11	IGBT temperature																																	
※ The default setting is 4, that is to reset the displayed item to [Output voltage command].																																				
n0.05	0005	User setup being monitored	Multiply the output frequency with a factor to display the desired value. Set a factor for output frequency in $\times$ n0.05. User setup being monitored "U****"=Output frequency n0.05 set value	0.1 ~ 160.0	0.1	1.0	○																													
n0.06	0006	Software No. (Power) ※ Only for reference	Display the software edition installed in the driver.	—	00.01	—	—	3-7																												

## ● n1:set v/f mode and acceleration/deceleration time

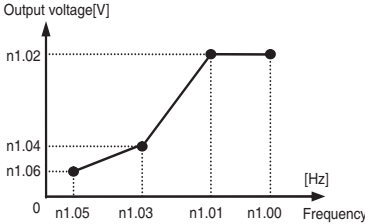
Parameter No.	Register No. (Hex)	Name	Description	Setting range	Unit of setting	Default setting	Changes during operation	Reference page
n1.00	0100	Maximum frequency (FMAX)	Set basic characteristics for the inverter, i.e. the V/f mode. ● V/f control mode: Set output voltages for different frequencies.	50.00 ~ 600.0	0.01 Hz	50.00 ※ 1	×	5-2
n1.01	0101	Maximum voltage frequency (FA)	● Vector control mode: Vector control is used to control frequency and voltage, therefore the settings in n1.03, n1.04, n1.06 are disabled.	0.10 ~ 600.0	0.01 Hz	50.00 ※ 1	×	5-2
n1.02	0102	Maximum voltage (VMAX)	Output voltage[V] 	0.1 ~ 255.0(0.1 ~ 510.0) ※ 2	0.1V	200.0 (400.0) ※ 2	×	5-2
n1.03	0103	Middle output frequency (FB)		0.10 ~ 600.0	0.01 Hz	1.5	×	5-2
n1.04	0104	Middle output frequency voltage (VC)		0.1 ~ 255.0(0.1 ~ 510.0) ※ 2	0.1V	12.0 (24.0) ※ 2	×	5-2
n1.05	0105	Minimum output frequency (FMIN)	※ Set the parameters so that the following condition will be satisfied: $n1.05 \leq n1.03 \leq n1.01$ . ※ Set the parameters so that $n1.06 \leq n1.04 \leq n1.02$ . ※ When $n1.03 = n1.01$ , setting in n1.04 becomes invalid.	0.10 ~ 600.0	0.01 Hz	1.5	×	5-2
n1.06	0106	Minimum output frequency voltage (VMIN)	※ When $n1.03 = n1.05$ , setting in n1.06 becomes invalid.	0.1 ~ 255.0(0.1 ~ 510.0) ※ 2	0.1V	12.0 (24.0) ※ 2	×	5-2
n1.07	0107	Upper limit of frequency command	Set the upper/lower limit of frequency command. Inverter outputs the upper limit or lower limit when frequency command above the upper limit or below the lower limit is received.	0.1 ~ 120	0.1 %	110.0	×	5-7
n1.08	0108	Lower limit of frequency command	Set the parameter with the maximum frequency (n1.00) referred to 100%, and % as the setting unit. ※ Parameters must be set to ensure $n1.08 \leq n1.07$ . ※ In case the lower limit of frequency command ( $n1.08$ ) < Minimum Output Frequency (n1.05), even when a frequency less than n1.05 is input, no output occurs on the inverter.	0.0 ~ 100	0.1 %	0.0	×	5-7
n1.09	0109	Acceleration time 1	Acceleration time: Set the time from 0% to 100% of the maximum frequency (n1.00). Deceleration time: Set the time from 100% to 0% of the maximum frequency (n1.00). ※ The actual acceleration or deceleration time is obtained from the following formula. [Acceleration/Deceleration time set value] × [Frequency command value]/[Maximum frequency]	0.1 ~ 600.0	0.1s	10.0	○	5-14
n1.10	010A	Deceleration time 1				10.0	○	5-14
n1.11	010B	Acceleration time 2				10.0	○	5-14
n1.12	010C	Deceleration time 2	※ Acceleration/Deceleration time 1 and 2 can be changed over by setting the multi-function input (n4.05 ~ n4.08) to "7 (acceleration/deceleration time changeover)"			10.0	○	5-14
n1.17	0111	S-shape acceleration characteristic	Set S-shape acceleration/deceleration characteristics in order to reduce the impact on the loads. Add the S-shape characteristic time to the acceleration/ deceleration time set in n1.09 ~ n1.12. The actual acceleration/deceleration time is the acceleration/ deceleration time set value (n1.09~n1.12) added by the S-shape characteristic time set value (n1.17 or n1.18). ※ Set the S-shape characteristic time to "0.0 (0.00)" to disable the parameter.	0.1 ~ 10.0	0.1s	0.0	×	5-15
n1.18	0112	S-shape deceleration characteristic				0.0	×	5-15

## Chapter 10 List of Parameters

※ 1. Default value. When  $n0.02 = 10$  [Initialization at the maximum frequency of 60 Hz], the set value will change to 60Hz.

※ 2. Figures in the parentheses are the setting range and default value of 400VAC inverters.

### ● n2: Inverter operation mode settings

Parameter No.	Register No. (Hex)	Name	Description	Setting range	Unit of setting	Default setting	Changes during operation	Reference page
n2.00	0200	Frequency command selection	<p>Select the method to input frequency command to the inverter</p> <p>0: Increment/Decrement key on the operator enabled            1: Frequency command knob on the operator enabled            2: Frequency command input terminal A1 (voltage input 0~10V) enabled            3: Multi-function analog input terminal A1 (current input 4~20mA) enabled            4: RS485 communication link frequency command enabled</p> <p>※ When UP/DOWN command (set to 10, 11) is used in multi-function input (n4.05~n4.08), set n2.00 to 0. In this case, input from Increment/Decrement key on operator is also enabled. The multi-function input UP/DOWN command however takes the priority.</p> <p>※ Multi-step speed command(set to 01, 02, 03) of the multi-function inputs(n4.05~n4.08) will not be impacted by n2.00 setting and be enabled all the time.</p> <p>※ Choose terminal A1 current/voltage input, use the SW to ACI/AVI.</p>	0 ~ 4	1	1	○	5-6
n2.01	0201	Operation command selection	<p>Select RUN/STOP command input method for the inverter.</p> <p>0: RUN/STOP key of operator enabled            1: Control circuit terminal (2-wire or 3-wire) enabled            ※ STOP key on the operator is also enabled.            2: Control circuit terminal (2-wire or 3-wire) enabled            ※ STOP key on the operator is also enabled.            3. RS485 communication link operation command enabled            ※ STOP key on the operator is also enabled.            4. RS485 communication link operation command enabled            ※ STOP key on the operator is disabled.</p> <p>※ Set the multi-function inputs (n4.05~n4.08) respectively to "18 (operation command changeover: control terminal)", "19 (operation command changeover: operator)" and "20 (operation command changeover: communication)" to switch the operation commands temporarily.</p>	0 ~ 4	1	0	○	5-4
n2.02	0202	Stop mode selection	<p>Select the stop mode in case o stop command or external fault inputs.</p> <p>0: Decelerates to stop upon stop command/Coasts to stop for external fault            1: Coasts to stop upon stop command/Coasts to stop for external fault            2: Decelerates to stop upon stop command/ Decelerates to stop for external fault            3: Coasts to stop upon stop command/ Decelerates to stop for external fault</p>	0 ~ 3	1	0	×	5-16

Parameter No.	Register No. (Hex)	Name	Description	Setting range	Unit of setting	Default setting	Changes during operation	Reference page
n2.03	0203	Carrier frequency selection	Set the output carrier frequency for the inverter. ※ Generally the default value is used. ※ Set to a higher value to reduce the motor noise. ※ Set to a lower value to reduce the effect by electrical noise. ※ If the carrier frequency set value is higher, the inverter will be hot. If the set value is higher than 8 kHz, the rated output current will decrease.	2 ~ 15	kHz	8	×	6-3
n2.04	0204	Reverse rotation-prohibit selection	Select the operation with the reverse command input. 0: Reverse enabled (forward enabled) 1: Reverse disabled (forward enabled) 2: Reverse enabled (forward disabled)	0 ~ 2	1	0	×	5-16
n2.05	0205	Operation selection after power on /operation change over command	Set the operation commands enabled/disabled input earlier after power on or upon operation changeover command. 0: Enabled after power on/disabled upon operation changeover command 1: Disabled after power on/ disabled upon operation changeover command 2: Enabled after power on/ enabled upon operation changeover command 3: Disabled after power on/ enabled upon operation changeover command ※ It must be enabled when operation command is input again after power on or upon operation changeover command.	0 ~ 3	1	1	×	5-5
n2.06	0206	frequency command input (Terminal A1) loss of detection selection	Set the operation with loss of frequency command input command. When frequency command input occurred at the default input current, loss will be detected if the input current is less than n4.15 set value (the minimum current value across the frequency command input terminal A1) 0: Decelerate to 0Hz (operates upon command) 1: Detect fault frequency command input signal with "AErr" (coasts to stop) displayed. 2: Detect exception without "ERR" displayed and operate under the frequency before disconnection. ※ When the fault frequency command input signal is detected with "AErr" displayed, it changes to reset after cause is removed (flash is eliminated). ※ Loss detection is disabled when the frequency command input set value is changed to 0~20mA or voltage is input.	0 ~ 2	1	0	×	5-10

## Chapter 10 List of Parameters

Parameter No.	Register No. (Hex)	Name	Description	Setting range	Unit of setting	Default setting	Changes during operation	Reference page
n2.09	0209	Secondary frequency command selection	<p>Select the input method of the secondary frequency command frequency.</p> <p>※ The secondary frequency command method is used via setting the secondary frequency command operation selection (n2.10).</p> <p>※ Frequency command input can be changed over by setting the multi-function input (n4.05~n4.08) to "22 (Secondary frequency command)".</p> <p>0: Increment/decrement key of the operator enabled            1: Frequency command knob of the operator enabled            2: Frequency command input terminal A1 (input voltage 0~10V) enabled            3: Multi-function analog input terminal A1 (input current 4~20mA) enabled            4: RS485 communication link frequency command enabled</p> <p>※ When UP/DOWN command (value 10, 11) is used in the multi-function inputs (n4.05~n4.08), set n2.09 = 0. Increment/decrement key of the operator is also enabled. However, the multi-function input UP/DOWN command takes the priority.</p> <p>※ Multi-step speed command (1, 2, 3) of the multi-function inputs (n4.05~n4.08) will not be impacted by n2.09 setting and be enabled all the time.</p> <p>※ Choose frequency command input current/voltage, use the switch to AC1/AV1.</p>	0 ~ 4	1	2	○	5-6
n2.10	020A	Second frequency command operation selection	<p>Select the operation method for the secondary frequency command.</p> <p>0: Disabled            Actual frequency command = Frequency command (n2.00)</p> <p>1: Enabled            Actual frequency command = Frequency command (n2.00)+Secondary frequency command (n2.09)</p> <p>2: Enabled            Actual frequency command= Frequency command (n2.00)-Secondary frequency command (n2.09)</p>	00 ~ 02	1	0	○	5-6
n2.13	020D	Operator communication frequency command memory selection	<p>Select whether the frequency command sent by operator and communication link is stored or not.</p> <p>0:Store the operator frequency command/store communication link frequency command            1:Store the operator frequency command/not store communication link frequency command            2:Not store the operator frequency command/store communication link frequency command</p> <p>※ When the parameter is set to not store, the frequency command will operate with "0.00" after power ON.</p>	0 ~ 2	1	0	×	5-8 5-13

## ● n3: Inverter output function settings

Parameter No.	Register No. (Hex)	Name	Description	Setting range	Unit of setting	Default setting	Changes during operation	Reference page		
n3.00	0300	Multi-function output 1 (output terminals MA/MB and MC)	Select the functions of multi-function output terminals.	0 ~ 21	1	8	×	5-18		
			Set value						Function	Description
			0						Multi-function output disabled	Multi-function output disabled
			1						Operation in progress	ON: Operation in progress (operation output/inverter output in progress)
			2						Frequency consistent	ON: Frequency consistent (with the frequency command)
			3						Idling 1	ON: Idling (at less than minimum output frequency) ※ Operation command is ON, if not in output status, the operation command is OFF.
			4						Overtorque being detected	ON: Output if any of the following conditions is satisfied • Overtorque detection function selection (n6.03) • Overtorque detection level (n6.04) • Overtorque detection time (n6.05)
			5						Base block in progress	ON: Base block in progress (Base block command input in progress)
			6						Low voltage being detected	ON: Low voltage being detected (when the low voltage UV on the main circuit is detected) ※ Low voltage is detected when the DC voltage of the main circuit is 198VDC for 200VAC model and 396VDC for 400VAC model.
7	Operation command input	ON: Control circuit terminals OFF: Except for the control circuit terminals								

## Chapter 10 List of Parameters

Parameter No.	Register No. (Hex)	Name	Description			Setting range	Unit of setting	Default setting	Changes during operation	Reference page
			8	Fault output	ON: Fault output					
			9	Frequency detection	ON: Output frequency $\geq$ frequency detection level (n3.02)					
			12	Stall prevention during deceleration in progress	ON: Stall prevention during deceleration in progress (n6.00)					
			13	Stall prevention during acceleration /operation in progress	ON: Stall prevention during acceleration/operation in progress (n6.01/n6.02)					
			14	Inverter overheating alarm	ON: Inverter overheating alarm (temperature of radiation fin is above 85 °C )					
			15	Overvoltage alarm	ON: Overvoltage alarm (Voltage on the main circuit exceeds the alarm voltage) ※ Alarm voltage: The DC voltage of the main circuit: 200V; 200VAC model: 374V; 400V AC model: 747V					
			17	Rotating in forward direction	ON: Rotating in forward direction					
			18	Rotating in reverse direction	ON: Rotating in reverse direction					
			19	Idling 2	ON: Idling (at minimum output frequency) ※ Output continues when operation command STOP					
			20	Alarm output	ON: Alarm output					
			21	External brake output	ON: External brake applied ※ Set the control time in the external brake application frequency (n3.11) and external brake operation frequency (n3.12).					
n3.02	0302	Frequency detection level	Set the frequency desired to be detected. ※ Set the multi-function output (n3.00) to "9 (frequency detection)".			0.00 ~ 600.0	0.01 Hz	0.0 0	×	5-18
n3.03	0303	Multi-function analog output selection	Select the items being monitored by the multi-function analog output. 0: Output frequency being monitored (0~10V/0~Maximum Frequency n1.00) 1: Output current being monitored (0~10V/0~250% of the inverter rated output current) ※ Adjust output voltage of multi-function analog output in multi-function analog output gain (n3.04).			0,1	1	0	○	5-21

Parameter No.	Register No. (Hex)	Name	Description	Setting range	Unit of setting	Default setting	Changes during operation	Reference page
n3.04	0304	Multi-function analog output gain (output terminals AM-AC)	To adjust voltage in the multi-function analog output, set the output voltage gain. When output voltage gain is set to 100%, output is determined by the following equation. n3.03 = 0: Output frequency being monitored (0~10V/0~Maximum frequency n1.00) n3.03 = 1: Output current being monitored (0~10V/0~250% of the inverter rated output current) ※ If output voltage gain is set to 50%, the output voltage is 5V under the same conditions.	1 ~ 200	1%	100	○	5-21
n3.08	n3.08	Cooling fan operation selection	Set the cooling fan operation. 0: Rotates only when RUN command is input 1: Rotates when the inverter is turned ON (for 1 minute after the inverter stops operation) 2: Rotates when the inverter is turned ON (Stops when the inverter stops) 3: Rotates according to IGBT temperature conditions (Operates above 60 °C and stops below 40 °C )	0 ~ 3	1	1	×	6-13
n3.11	030B	External brake release frequency	Set the control signals for external brake operations. Set the external brake release/external brake operation time according to the inverter output frequency.	0.00 ~ 20.00	0.01 Hz	0.00	×	6-6
n3.12	030C	External brake operation frequency	※ Set the multi-function output (n3.00) to "21 (external brake output)" to connect with external brake. ※ Set the brake operation value coincident with the inverter output status value Hz in order to prevent the vertical shaft from dropping.	0.00 ~ 20.00	0.01 Hz	0.00	×	6-6

● n4: Inverter input function settings

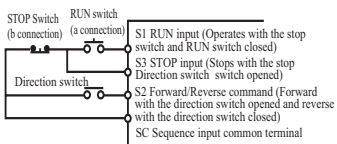
Parameter No.	Register No. (Hex)	Name	Description	Setting range	Unit of setting	Default setting	Changes during operation	Reference page
n4.04	0404	Multi-function input 1/2 selection (Input terminal S1/S2)	Input the control circuit terminal operation command from the multi-function input 1/2. Set the input method according to actual application. 0: 2-wire sequence (Forward /stop (Terminal S1), Reverse/stop (Terminal S2)) 1: 2-wire sequence (Run/stop (Terminal S1), Forward/Reverse (Terminal S2)) 2: 3-wire sequence ※ When n4.04 = 2, even if 3-wire sequence input is set, 3-wire sequence allocation is performed while the multi-function input 3 (n4.05) set value is disabled.  	0 ~ 2	1	0	×	5-4

## Chapter 10 List of Parameters

Parameter No.	Register No. (Hex)	Name	Description			Setting range	Unit of setting	Default setting	Changes during operation	Reference page													
n4.05	0405	Multi-function input 3 selection (Input terminal S3)	Select the functions of multi-function input terminals 3 through 6.			0 ~ 22	1	14	×	5-17													
n4.06	0406	Multi-function input 4 selection (Input terminal S4)	Set value	Function	Description			5	×	5-17													
n4.07	0407	Multi-function input 5 selection (Input terminal S5)	0	Multi-function input disabled	Multi-function input is disabled			1	×	5-17													
n4.08	0408	Multi-function input 6 selection (Input terminal S6)	1	Multi-step speed command 1	Signals to select frequency commands 1 through 15 (n5.00~n5.06). ※ Refer to frequency commands 1~15 (n5.00~n5.06) for details.			2	×	5-17													
			2	Multi-step speed command 2																			
			3	Multi-step speed command 3																			
			5	Fault reset	ON: Fault reset (disabled when RUN command is input)																		
			7	Acceleration/deceleration time changeover	ON: Acceleration/deceleration time 2 (n1.11, n1.12).																		
			9	External base block command	ON: Output shut off																		
			10	Up command (UP/DOWN command)	UP/DOWN command of increasing/decreasing frequency command. Both UP command and Down command must be set.						5-17												
			11	Down command (UP/DOWN command)		<table border="1"> <thead> <tr> <th>Status</th> <th>ACC</th> <th>DEC</th> <th>Hold</th> <th>Hold</th> </tr> </thead> <tbody> <tr> <td>UP command</td> <td>ON</td> <td>OFF</td> <td>OFF</td> <td>ON</td> </tr> <tr> <td>DOWN command</td> <td>OFF</td> <td>ON</td> <td>OFF</td> <td>ON</td> </tr> </tbody> </table> <p>※ UP/DOWN command and multi-step speed references 1 through 3 can be used simultaneously. ※ Set n2.13 to 0 or 1 to store the UP/DOWN command frequency when power OFF.</p>	Status	ACC	DEC	Hold	Hold	UP command	ON	OFF	OFF	ON	DOWN command	OFF	ON	OFF	ON		
			Status	ACC	DEC	Hold	Hold																
			UP command	ON	OFF	OFF	ON																
DOWN command	OFF	ON	OFF	ON																			
14	External fault	ON: External fault (EF error is detected)						5-17															
16	Coast to stop	ON: Stops output and coasts to stop ※ After output is removed restarts from 0Hz.						5-17															
17	Parameter write-prohibit	ON: Parameter write prohibit						5-17															

Parameter No.	Register No. (Hex)	Name	Description	Setting range	Unit of setting	Default setting	Changes during operation	Reference page												
			<table border="1"> <tr> <td>18</td> <td>Operation command changeover (Control circuit terminal)</td> <td>ON: Operation command sent by control circuit terminal enabled OFF: Operation command selection (n2.01) enabled</td> </tr> <tr> <td>19</td> <td>Operation command changeover (Operator)</td> <td>ON: RUN/STOP key on the operator enabled OFF: Operation command selection (n2.01) enabled</td> </tr> <tr> <td>20</td> <td>Operation command changeover (communication)</td> <td>ON: Communication link operation command enabled OFF: Operation command selection (n2.01) enabled</td> </tr> <tr> <td>22</td> <td>Secondary frequency command</td> <td>ON: Secondary frequency command (n2.09) enabled</td> </tr> </table>	18	Operation command changeover (Control circuit terminal)	ON: Operation command sent by control circuit terminal enabled OFF: Operation command selection (n2.01) enabled	19	Operation command changeover (Operator)	ON: RUN/STOP key on the operator enabled OFF: Operation command selection (n2.01) enabled	20	Operation command changeover (communication)	ON: Communication link operation command enabled OFF: Operation command selection (n2.01) enabled	22	Secondary frequency command	ON: Secondary frequency command (n2.09) enabled					5-17
18	Operation command changeover (Control circuit terminal)	ON: Operation command sent by control circuit terminal enabled OFF: Operation command selection (n2.01) enabled																		
19	Operation command changeover (Operator)	ON: RUN/STOP key on the operator enabled OFF: Operation command selection (n2.01) enabled																		
20	Operation command changeover (communication)	ON: Communication link operation command enabled OFF: Operation command selection (n2.01) enabled																		
22	Secondary frequency command	ON: Secondary frequency command (n2.09) enabled																		
								5-17												
								5-17												
								5-17												
n4.09	0409	Multi-function input a connection/b connection input selection	<p>Select the multi-function input from a connection (NO) or b connection (NC). When b connection (NC) is set to 1, the binary value is converted to decimal value. "11" = 00000001011 → Multi-function inputs 1, 2, 4 are set by b connection (NC) input</p> <p>0:a connection(N.O.) 1:b connection(N.C.) Multi-function input 1(S1) Multi-function input 2(S2) Multi-function input 3(S3) Multi-function input 4(S4) Multi-function input 5(S5) Multi-function input 6(S6)</p>	0 ~ 63	1	0	×	6-5												
n4.10	040A	Input terminal response time	<p>Set the input response time for input terminals. Generally it is not required to set. Set the parameter to a higher value to prevent relay vibration or electrical noise in unit of 2ms.</p>	1 ~ 20	1(2 ms)	1	×	6-6												

## Chapter 10 List of Parameters

Parameter No.	Register No. (Hex)	Name	Description	Setting range	Unit of setting	Default setting	Changes during operation	Reference page	
n4.11	040B	Frequency command input terminal A1 minimum voltage input	<p>Change and adjust the frequency command input (terminal A1) analog input characteristics.</p> <p>Set the characteristics desired to be changed according to the following figure.</p> <p>※ Command value is set with the maximum frequency (n1.00) being 100%, in unit of 0.1%.</p> <p>※ Choose A1 input current/voltage, use the switch to ACI/AVI.</p> <p>ACI: current input(4 ~ 20mA) AVI: voltage input(0 ~ 10V)</p>	0.0 ~ 10.0	0.1 V	0.0	×	5-10	
n4.12	040C	Frequency command input terminal A1 minimum voltage command value		0.0 ~ 100.0	0.1 %	0.0	×	5-10	
n4.13	040D	Frequency command input terminal A1 maximum voltage input		0.0 ~ 10.0	0.1 V	10.0	×	5-10	
n4.14	040E	Frequency command input terminal A1 maximum voltage command value		0.0 ~ 100.0	0.1 %	100.0	×	5-10	
n4.15	040F	Frequency command input terminal A1 minimum current input		n4.14 n4.18	0.0 ~ 20.0	0.1 mA	4.0	×	5-10
n4.16	0410	Frequency command input terminal A1 minimum current command value		n4.12 n4.16	0.0 ~ 100.0	0.1 %	0.0	×	5-10
n4.17	0411	Frequency command input terminal A1 maximum current input		0V 0mA	0.0 ~ 20.0	0.1 mA	20.0	×	5-10
n4.18	0412	Frequency command input terminal A1 maximum current command value		n4.11 n4.15	0.0 ~ 100.0	0.1 %	100.0	×	5-10
n4.27	041B	Input terminal internal input selection		Allocate the input terminals to internal inputs, which allows the internal inputs to be set to a fixed status. This parameter is available when starting the inverter in fixed status after power ON without wiring.	0 ~ 63	1	00	×	64
n4.28	041C	Internal input status selection		<p>※ Set the input terminal internal input selection (n4.27) to allocate to the internal inputs. Set the values with internal input status of 1 and displayed after being converted from binary to decimal.</p> <p>※ Set in the internal input status selection (n4.28) the fixed status of internal inputs. Set the input fixed status (a connection is ON) to 1, with the set values converted from binary values to decimal values. For example: Value "11"=000000001011</p> <p>n4.27 → multi-function inputs 1, 2 and 4 are allocated to the internal input setting n4.28 → multi-function inputs 1, 2 and 4 are in input fixed status (a connection is ON)</p> <p>n4.27=1: Internal input setting n4.28=1: Input fixed status</p>	0 ~ 63	1	00	○	64

## ● n5: Multi-step speed frequency command setting

Parameter No.	Register No. (Hex)	Name	Description					Setting range	Unit of setting	Default setting	Changes during operation	Reference page
n5.00	0500	Frequency command 1	Set the internal frequency commands. ※ Select the internal frequency commands with the multi-function inputs (n4.05~n4.08) set to multi-step speed command (set value 01, 02, 03).					0.0 0 ~ 600.0	0.01 Hz	0.00	○	5-9
n5.01	0501	Frequency command 2								0.00	○	
n5.02	0502	Frequency command 3	Frequency command	Multi-step speed command 1 (set value: 01)	Multi-step speed command 2 (set value: 02)	Multi-step speed command 3 (set value: 03)	Multi-step speed command 4 (set value: 04)	0.00	○			
n5.03	0503	Frequency command 4	Frequency command selection (n2.00)	×	×	×	×	0.00	○			
n5.04	0504	Frequency command 5	Frequency command 1	○	×	×	×	0.00	○			
n5.05	0505	Frequency command 6	Frequency command 2	×	○	×	×	0.00	○			
n5.06	0506	Frequency command 7	Frequency command 3	○	○	×	×	0.00	○			
			Frequency command 4	×	×	○	×					
			Frequency command 5	○	×	○	×					
			Frequency command 6	×	○	○	×					
			Frequency command 7	○	○	○	×					
			※○ indicates input status (a connection is ON),while × indicates non input status (a connection is OFF)									

## ● n6: Protection function settings

Parameter No	Register No. (Hex)	Name	Description	Setting range	Unit of setting	Default setting	Changes during operation	Reference page
n6.00	0600	Operation level for stall prevention during deceleration	Set the operation level under which deceleration time function automatically stops in order to prevent overvoltage (OV) during deceleration. Set with the voltage value of DC power supply of the main circuit. Generally it is not required to change the set value. ※ When stall prevention during deceleration is enabled, overvoltage is detected, set the parameter to a lower value. If the parameter is set too low, the inverter can not deceleration, causing the stop duration very long, which should be attended to.	0.0, 330.0 ~ 410.0 (0.0, 660.0 ~ 820.0) ※ 2	01V	390.0 (700) ※ 2	×	6-9

## Chapter 10 List of Parameters

Parameter No	Register No. (Hex)	Name	Description	Setting range	Unit of setting	Default setting	Changes during operation	Reference page
n6.01	0601	Operation level for stall prevention during acceleration	Set the operation level under which the acceleration function automatically stops to avoid the stall status during acceleration. Set the parameter in unit of % with the inverter rated output current referred to 100%. ※ When the parameter is set to "0.0", stall prevention during acceleration function is disabled.	0,20 ~ 250	1%	170	×	6-9
n6.02	0602	Operation level for stall prevention during running	Set the operation level under which the acceleration function automatically stops to avoid the stall status during running. Set the parameter in % with the inverter rated output current referred to 100%. ※ When the parameter is set to "0.0", stall prevention during running function is disabled.	0,20 ~ 250	1%	170	×	6-10
n6.03	0603	Overtorque detection selection	Enable or disable the overtorque detection and how to process after overtorque is detected. 0: Overtorque detection disabled. 1: Only detection in speed consistency/Continue to run with overtorque being detected (detection alarm) 2: Only detection in speed consistency/Stop output with overtorque being detected (fault detection) 3: Detection during running/Continue to run with overtorque being detected (detection alarm) 4: Detection during running/Stop output with overtorque being detected (fault detection) ※ Exceeding the overtorque detection level (n6.04) continues to exist for certain of duration after the overtorque detection time (n6.05) lapses will be detected. ※ When overtorque is being detected, if it is error detect, "OL2" is displayed, flash until stop output. If it is alarm detect, "OL2" is displayed, flash until no overtorque is being detected. ※ If the multi-function output (n3.00) is set to "04 (overtorque being detected)", output to external is enabled.	0 ~ 4	1	0	×	6-7
n6.04	0604	Level for overtorque being detected	Set the level under which overtorque is being detected with the inverter rated output current being 100%, and % as the setting unit.	10 ~ 200	1%	150	○	6-7
n6.05	0605	Time for overtorque being detected	Set the duration for overtorque being detected.	0.1 ~ 60.0	0.1s	0.1	×	6-7
n6.06	0606	Motor protection function selection	Set the overload prevention characteristics for connecting with motor (electronic temperature sensitive characteristics). 0: Protection operation corresponding to the general induction motor 1: Protection operation corresponding to the special motor for inverter 2: Motor overload prevention function disabled ※ Motor rated current (n7.00) must be set in order to enable the electronic temperature sensitive function to detect the motor overload (OL1) properly. ※ If 2 or above motors are connected to the same inverter, set the n6.06 to 2.	0 ~ 2	1	0	×	6-11
n6.07	0607	Motor protection operation duration	Set the electronic temperature sensitive protection for motor overload being detected (OL1) with seconds. The default setting is 150% withhold 1 minute. ※ Generally, it is not necessary to change the default setting.	30 ~ 600	1 s	60	×	6-11

Parameter No	Register No. (Hex)	Name	Description				Setting range	Unit of setting	Default setting	Changes during operation	Reference page
			No.	Function	No.	Function					
n6.08	0608	Error history record 1 (before 1 time)	2 error history records can be stored at the most. This parameter is used for analysis of fault cause. The error history records are stored with the following codes.				—	1	0	×	3-7
n6.09	0609	Error history record 2 (before 2 times)	No.	Function	No.	Function	—	1	0	—	3-7
			0	(No error)	21	Overvoltage detection circuit error "HPF2"					
			1	Overcurrent (hardware being detected) "OC"	22	Grounding short circuit detection error "HPF3"					
			2	Overvoltage "ov"	23	Overcurrent detection circuit error "HPF4"					
			3	Radiation fin overheated "oH1"	24	U phase circuit error "cF3.0"					
			4	Power supply base overheated "oH2"	25	V phase circuit error "cF3.1"					
			5	Inverter overload "oL"	26	W phase circuit error "cF3.2"					
			6	Motor overload "oL1"	27	Voltage control circuit error "cF3.3"					
			7	Overtorque detection "oL2"	28	Temperature detector 1 error "cF3.5"					
			8	External fault "EF"	29	Temperature detector 2 error "cF3.5"					
			9	Overcurrent during acceleration "ocA"	32	Multi-function analog input signal error "AErr"					
			10	Overcurrent during deceleration "ocD"							
			11	Overcurrent in normal status "ocn"							
			12	Grounding fault "GFF"							
			13	Low voltage on main circuit "Lv" ※ Not stored							
			14	Input power phase loss "PHL"							
			15	External base block "bb" ※ Not stored							

## Chapter 10 List of Parameters

Parameter No	Register No. (Hex)	Name	Description	Setting range	Unit of setting	Default setting	Changes during operation	Reference page
			18	EEPROM (CB) writing error "cf1.0"				
			19	EEPROM (CB) reading error "cf2.0"				
			20	Current limiting circuit error "HPP1"				
			※ 13: Main circuit low voltage "LV" and 15: External base block "bb" are not stored in the error history record.					

※ 2. Figures in the parentheses are the setting range and default value for 400VAC models.

### ● n7: Motor parameter settings

Parameter No	Register No. (Hex)	Name	Description	Setting range	Unit of setting	Default setting	Changes during operation	Reference page
n7.00	0700	Rated motor current	Set the rated motor current (A). Rated motor current is default to the standard current of motor overload detection (OL1) or vector control algorithm parameters.	※ 4	0.1A	※ 5	○	5-2
n7.01	0701	Motor no load current	Set the motor no load current (A).	※ 6	0.1A	※ 7	○	6-1
n7.02	0702	Torque compensation gain	Set the torque compensation gain. ※ Generally it is not necessary to change the default value. When torque is insufficient, set the parameter to a higher value. ※ When several motors are connected to the same inverter, current will increase, in this case, set the parameter to "0.0" to disable the function.	0.0 ~ 10.0	0.1	1.0	○	6-2
n7.03	0703	Slip compensation gain	Set the slip compensation gain. Slip compensation function requires setting of rated motor current (n7.00), motor no load current (n7.01). ※ This function is disabled by setting the parameter to 0.0.	0.00 ~ 10.0	0.01	0.00	○	6-1

※ 4. The setting range varies with the inverter capacity within 30~120% of the rated inverter output current.

※ 5. The default value varies with the inverter capacity, about 75% of the rated inverter output current.

※ 6. The setting range varies with the inverter capacity within 0~99% of the rated inverter output current.

※ 7. The default value varies with the inverter capacity, about 40% of the rated inverter output current.

## ● n8: Other function settings

Parameter No	Register No. (Hex)	Name	Description	Setting range	Unit of setting	Default setting	Changes during operation	Reference page
n8.00	0800	DC braking current	Apply DC current to brake the induction motor. Set DC braking current as percentage based on the rated inverter output current as 100% and in unit of %.	0 ~ 100	1%	50	×	6-8
n8.01	0801	DC braking time during startup		0.0 ~ 60.0	0.1s	0.0	×	6-8
n8.02	0802	DC braking time during stop		0.0 ~ 60.0	0.1s	0.5	×	6-8
n8.03	0803	DC braking starting frequency during stop	※ DC braking changes over with the minimum output frequency (n1.05) when startup. ※ This parameter is used to stop large moment load or decelerate to avoid FAN regeneration.	0.00 ~ 600.0	0.01 Hz	0.00	×	6-8
n8.04	0804	Operation selection after recovery from instant stop	Select the process method for instant power loss. 0: STOP 1: Continue to run (restart according to the speed search sent by frequency command) 2: Continue to run (restart according to the speed search sent by minimum output frequency) ※ Continue to run until the time set in the instant power loss compensation time (n8.05) lapses.	0 ~ 2	1	0	×	6-12
n8.05	0805	Instant power loss compensation time	Set the maximum duration when the process method after instant power loss is set to "continues to run". ※ When the instant power loss is longer than the preset time, "Lv" error will be detected. ※ If a too long time is set that the inverter internal power supply decreases completely, speed will not be searched and ordinary startup is conducted.	0.1 ~ 5.0	0.1s	2.0	×	6-12
n8.09	0809	Upper limit of leaping frequency 1	Set the leaping frequency to avoid mechanical resonance frequency.	0.00 ~ 600.0	0.01 Hz	0.00	×	6-13
n8.10	080A	Lower limit of leaping frequency 1		0.00 ~ 600.0	0.01 Hz	0.00	×	6-13
n8.11	080B	Upper limit of leaping frequency 2		0.00 ~ 600.0	0.01 Hz	0.00	×	6-13
n8.12	080C	Lower limit of leaping frequency 2		0.00 ~ 600.0	0.01 Hz	0.00	×	6-13
			※ Parameters must set to meet the following condition: $n8.09 \geq n8.10 \geq n8.11 \geq n8.12$ . ※ The functions are disabled by setting the parameters to 0.00.					
n8.15	080F	Number of fault retry	The function can restart by automatic reset in case of overvoltage (ov) and overcurrent (oc). ※ Set the maximum number of restarts.	0 ~ 10	1	0	×	6-13

## Chapter 10 List of Parameters

Parameter No	Register No. (Hex)	Name	Description	Setting range	Unit of setting	Default setting	Changes during operation	Reference page
n8.17	0811	Energy-saving control selection	Enable or disable the energy-saving control. 0: Disabled 1: Enabled ※ Control the electric power required for load operation in automatic control mode when the motor power factor is satisfied.	0,1	1	0	×	6-4

※ 2. Figures in the parentheses are the setting range and default value for 400VAC models.

### ● n9: RS485 communication settings

Parameter No	Register No. (Hex)	Name	Description	Setting range	Unit of setting	Default setting	Changes during operation	Reference page
n9.00	0900	RS485 communications slave address	Set the slave address (Slave unit number) for communications. ※ RS485 communication is disabled by setting the parameter to 0.0.	0 ~ 254	1	0	×	7-2
n9.01	0901	RS485 baud rate selection	Set the baud rate for communications. 0: 4800 bps 1: 9600 bps 2: 19200 bps 3: 38400 bps	0 ~ 3	1	1	×	7-2
n9.02	0902	Operation selection upon RS485 communications error detected	Select the operations when a communication error (CE □ ) is detected. 0: Continues to run with alarm displayed 1: Decelerates to stop with alarm displayed 2: Coasts to stop with alarm displayed 3: Continues to run (no alarm displayed)	0 ~ 3	1	2	×	7-2
n9.04	0904	RS485 send wait time	Set the waiting period for returning a response after the DSR (data-send-request) message is received from the Master with a setting increment of 2ms.	0 ~ 200	1(2 ms)	0	×	7-2
n9.05	0905	RS485 communications time-out detection period	Set the detection period for communication time-out. Set the detection period according to the communication program. ※ Communication time-out detection is disabled by setting the parameter to 0.0.	0.0 ~ 120.0	0.1s	1.0	×	7-2

