

CJ-series Built-in I/O
CJ1M-CPU21/22/23

CJ1M CPU Units

OPERATION MANUAL

OMRON

Wiki *دانشگاه آنلاین*
LZonline

lalehzaronline.com/wiki

CJ-series Built-in I/O CJ1M-CPU21/22/23 CPU Units



Operation Manual

Revised February 2008

Notice:

OMRON products are manufactured for use according to proper procedures by a qualified operator and only for the purposes described in this manual.

The following conventions are used to indicate and classify precautions in this manual. Always heed the information provided with them. Failure to heed precautions can result in injury to people or damage to property.

-  **DANGER** Indicates an imminently hazardous situation which, if not avoided, will result in death or serious injury. Additionally, there may be severe property damage.
-  **WARNING** Indicates a potentially hazardous situation which, if not avoided, could result in death or serious injury. Additionally, there may be severe property damage.
-  **Caution** Indicates a potentially hazardous situation which, if not avoided, may result in minor or moderate injury, or property damage.

OMRON Product References

All OMRON products are capitalized in this manual. The word “Unit” is also capitalized when it refers to an OMRON product, regardless of whether or not it appears in the proper name of the product.

The abbreviation “Ch,” which appears in some displays and on some OMRON products, often means “word” and is abbreviated “Wd” in documentation in this sense.

The abbreviation “PLC” means Programmable Controller. “PC” is used, however, in some Programming Device displays to mean Programmable Controller.

Visual Aids

The following headings appear in the left column of the manual to help you locate different types of information.

Note Indicates information of particular interest for efficient and convenient operation of the product.

- 1,2,3...** 1. Indicates lists of one sort or another, such as procedures, checklists, etc.

© OMRON, 2002

All rights reserved. No part of this publication may be reproduced, stored in a retrieval system, or transmitted, in any form, or by any means, mechanical, electronic, photocopying, recording, or otherwise, without the prior written permission of OMRON.

No patent liability is assumed with respect to the use of the information contained herein. Moreover, because OMRON is constantly striving to improve its high-quality products, the information contained in this manual is subject to change without notice. Every precaution has been taken in the preparation of this manual. Nevertheless, OMRON assumes no responsibility for errors or omissions. Neither is any liability assumed for damages resulting from the use of the information contained in this publication.

Unit Versions of CS/CJ-series CPU Units

Unit Versions

A “unit version” has been introduced to manage CPU Units in the CS/CJ Series according to differences in functionality accompanying Unit upgrades. This applies to the CS1-H, CJ1-H, CJ1M, and CS1D CPU Units.

Notation of Unit Versions on Products

The unit version is given to the right of the lot number on the nameplate of the products for which unit versions are being managed, as shown below.

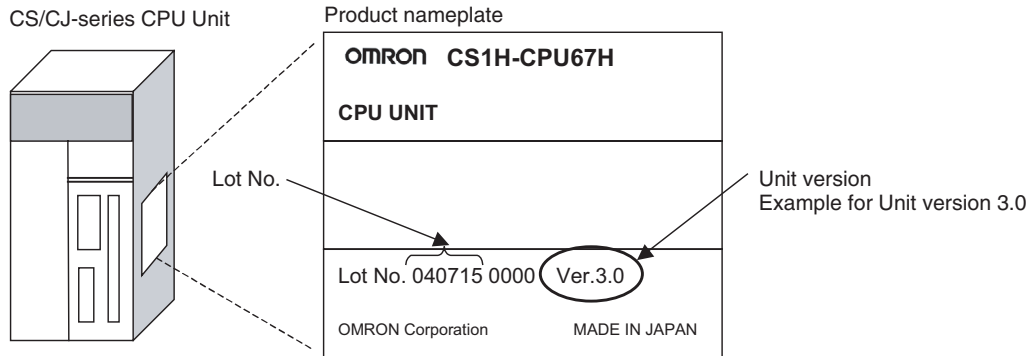

- CS1-H, CJ1-H, and CJ1M CPU Units manufactured on or before November 4, 2003 do not have a unit version given on the CPU Unit (i.e., the location for the unit version shown above is blank).
- The unit version of the CS1-H, CJ1-H, and CJ1M CPU Units, as well as the CS1D CPU Units for Single-CPU Systems, begins at version 2.0.
- The unit version of the CS1D CPU Units for Duplex-CPU Systems, begins at version 1.1.
- CPU Units for which a unit version is not given are called *Pre-Ver.* □.□ *CPU Units, such as Pre-Ver. 2.0 CPU Units and Pre-Ver. 1.1 CPU Units.*

Confirming Unit Versions with Support Software

CX-Programmer version 4.0 can be used to confirm the unit version using one of the following two methods.

- Using the **PLC Information**
- Using the **Unit Manufacturing Information** (This method can be used for Special I/O Units and CPU Bus Units as well.)

Note CX-Programmer version 3.3 or lower cannot be used to confirm unit versions.

PLC Information

- If you know the device type and CPU type, select them in the *Change PLC* Dialog Box, go online, and select **PLC - Edit - Information** from the menus.
- If you don't know the device type and CPU type, but are connected directly to the CPU Unit on a serial line, select **PLC - Auto Online** to go online, and then select **PLC - Edit - Information** from the menus.

In either case, the following *PLC Information* Dialog Box will be displayed.

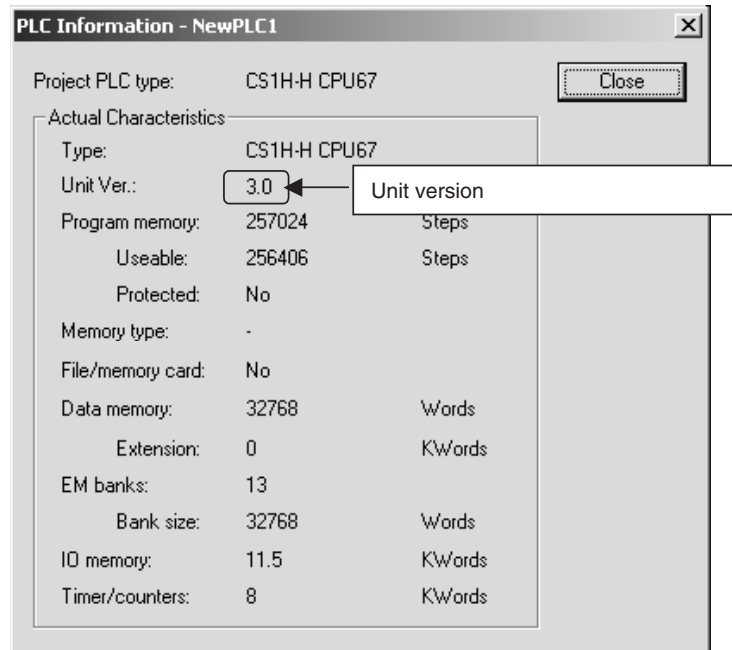

Use the above display to confirm the unit version of the CPU Unit.

Unit Manufacturing Information

In the IO Table Window, right-click and select ***Unit Manufacturing information - CPU Unit.***

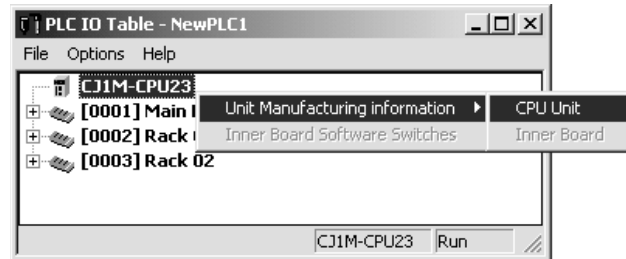

The following *Unit Manufacturing information* Dialog Box will be displayed.

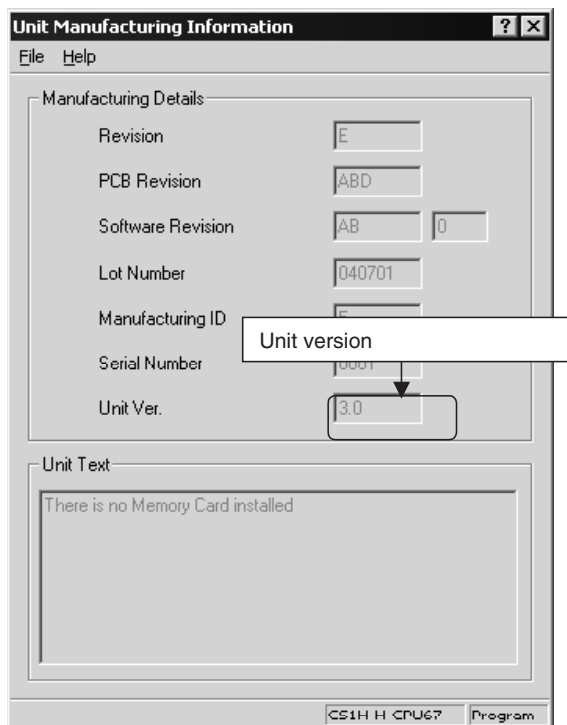

Use the above display to confirm the unit version of the CPU Unit connected online.

Using the Unit Version Labels

The following unit version labels are provided with the CPU Unit.

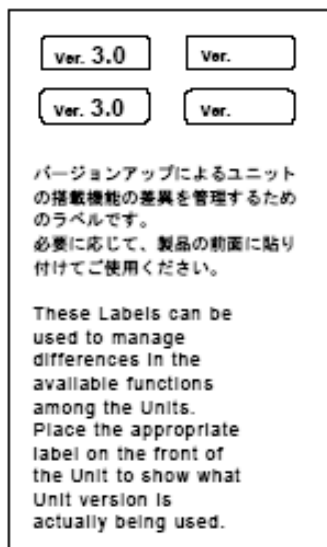

These labels can be attached to the front of previous CPU Units to differentiate between CPU Units of different unit versions.

Unit Version Notation

In this manual, the unit version of a CPU Unit is given as shown in the following table.

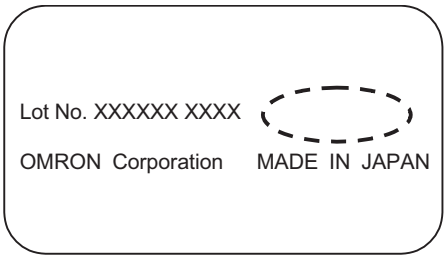
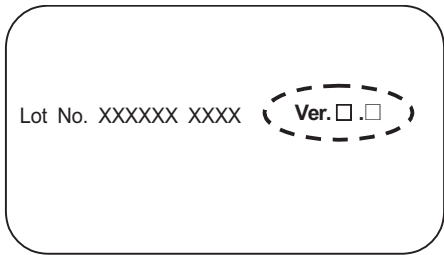
Product nameplate	CPU Units on which no unit version is given	Units on which a version is given (Ver. □.□)
Meaning Designating individual CPU Units (e.g., the CS1H-CPU67H) Designating groups of CPU Units (e.g., the CS1-H CPU Units) Designating an entire series of CPU Units (e.g., the CS-series CPU Units)		
	Pre-Ver. 2.0 CS1-H CPU Units	CS1H-CPU67H CPU Unit Ver. □.□
	Pre-Ver. 2.0 CS1-H CPU Units	CS1-H CPU Units Ver. □.□
	Pre-Ver. 2.0 CS-series CPU Units	CS-series CPU Units Ver. □.□

Unit Versions

CJ Series

Units	Models	Unit version
CJ1-H CPU Units	CJ1□-CPU□□H CJ1G-CPU□□P	Unit version 4.0
		Unit version 3.0
		Unit version 2.0
		Pre-Ver. 2.0
CJ1M CPU Units	CJ1M-CPU12/13 CJ1M-CPU22/23	Unit version 4.0
		Unit version 3.0
		Unit version 2.0
		Pre-Ver. 2.0
	CJ1M-CPU11/21	Unit version 4.0
		Unit version 3.0
		Unit version 2.0

NSJ Series

Units	Unit version
NSJ□-□□□□(B)-G5D NSJ□-□□□□(B)-M3D	Unit version 3.0

Function Support by Unit Version

• Functions Supported for Unit Version 4.0 or Later

CX-Programmer 7.0 or higher must be used to enable using the functions added for unit version 4.0.

CJ1-H/CJ1M CPU Units

Function		CJ1□-CPU□□H, CJ1G-CPU□□P, CJ1M-CPU□□	
		Unit version 4.0 or later	Other unit versions
Online editing of function blocks Note This function cannot be used for simulations on the CX-Simulator.		OK	---
Input-output variables in function blocks		OK	---
Text strings in function blocks		OK	---
New application instructions	Number-Text String Conversion Instructions: NUM4, NUM8, NUM16, STR4, STR8, and STR16	OK	---
	TEXT FILE WRITE (TWRIT)	OK	---

User programs that contain functions supported only by CPU Units with unit version 4.0 or later cannot be used on CS/CJ-series CPU Units with unit version 3.0 or earlier. An error message will be displayed if an attempt is made to download programs containing unit version 4.0 functions to a CPU Unit with a unit version of 3.0 or earlier, and the download will not be possible.

If an object program file (.OBJ) using these functions is transferred to a CPU Unit with a unit version of 3.0 or earlier, a program error will occur when operation is started or when the unit version 4.0 function is executed, and CPU Unit operation will stop.

• **Functions Supported for Unit Version 3.0 or Later**

CX-Programmer 5.0 or higher must be used to enable using the functions added for unit version 3.0.

CJ1-H/CJ1M CPU Units

Function		CJ1□-CPU□□H, CJ1G-CPU□□P, CJ1M-CPU□□	
		Unit version 3.0 or later	Other unit versions
Function blocks		OK	---
Serial Gateway (converting FINS commands to CompoWay/F commands at the built-in serial port)		OK	---
Comment memory (in internal flash memory)		OK	---
Expanded simple backup data		OK	---
New application instructions	TXDU(256), RXDU(255) (support no-protocol communications with Serial Communications Units with unit version 1.2 or later)	OK	---
	Model conversion instructions: XFERC(565), DISTC(566), COLLC(567), MOVBC(568), BCNTC(621)	OK	---
	Special function block instructions: GETID(286)	OK	---
Additional instruction functions	PRV(881) and PRV2(883) instructions: Added high-frequency calculation methods for calculating pulse frequency. (CJ1M CPU Units only)	OK	---

User programs that contain functions supported only by CPU Units with unit version 3.0 or later cannot be used on CS/CJ-series CPU Units with unit version 2.0 or earlier. An error message will be displayed if an attempt is made to download programs containing unit version 3.0 functions to a CPU Unit with a unit version of 2.0 or earlier, and the download will not be possible.

If an object program file (.OBJ) using these functions is transferred to a CPU Unit with a unit version of 2.0 or earlier, a program error will occur when operation is started or when the unit version 3.0 function is executed, and CPU Unit operation will stop.

• **Functions Supported for Unit Version 2.0 or Later**

CX-Programmer 4.0 or higher must be used to enable using the functions added for unit version 2.0.

CJ1-H/CJ1M CPU Units

Function	CJ1-H CPU Units		CJ1M CPU Units		
	CJ1□-CPU□□H CJ1G-CPU□□P		CJ1M-CPU12/13/22/23		CJ1M-CPU11/21
	Unit version 2.0 or later	Other unit versions	Unit version 2.0 or later	Other unit versions	Other unit versions
Downloading and Uploading Individual Tasks	OK	---	OK	---	OK
Improved Read Protection Using Passwords	OK	---	OK	---	OK
Write Protection from FINS Commands Sent to CPU Units via Networks	OK	---	OK	---	OK
Online Network Connections without I/O Tables	OK	--- (Supported if I/O tables are automatically generated at startup.)	OK	--- (Supported if I/O tables are automatically generated at startup.)	OK
Communications through a Maximum of 8 Network Levels	OK	---	OK	---	OK
Connecting Online to PLCs via NS-series PTs	OK	OK from lot number 030201	OK	OK from lot number 030201	OK
Setting First Slot Words	OK for up to 64 groups	OK for up to 8 groups	OK for up to 64 groups	OK for up to 8 groups	OK for up to 64 groups
Automatic Transfers at Power ON without a Parameter File	OK	---	OK	---	OK
Automatic Detection of I/O Allocation Method for Automatic Transfer at Power ON	---	---	---	---	---
Operation Start/End Times	OK	---	OK	---	OK
New Application Instructions	MILH, MILR, MILC	OK	---	OK	OK
	=DT, <>DT, <DT, <=DT, >DT, >=DT	OK	---	OK	OK
	BCMP2	OK	---	OK	OK
	GRY	OK	OK from lot number 030201	OK	OK from lot number 030201
	TPO	OK	---	OK	OK
	DSW, TKY, HKY, MTR, 7SEG	OK	---	OK	OK
	EXPLT, EGATR, ESATR, ECHRD, ECHWR	OK	---	OK	OK
	Reading/Writing CPU Bus Units with IORD/IOWR	OK	---	OK	OK
PRV2	---	---	OK, but only for CPU Units with built-in I/O	---	OK, but only for CPU Units with built-in I/O

User programs that contain functions supported only by CPU Units with unit version 2.0 or later cannot be used on CS/CJ-series Pre-Ver. 2.0 CPU Units. An error message will be displayed if an attempt is made to download programs containing unit version 2.0 functions to a Pre-Ver. 2.0 CPU Unit, and the download will not be possible.

If an object program file (.OBJ) using these functions is transferred to a Pre-Ver. 2.0 CPU Unit, a program error will occur when operation is started or when the unit version 2.0 function is executed, and CPU Unit operation will stop.

Unit Versions and Programming Devices

The following tables show the relationship between unit versions and CX-Programmer versions.

Unit Versions and Programming Devices

CPU Unit	Functions		CX-Programmer				Programming Console
			Ver. 3.3 or lower	Ver. 4.0	Ver. 5.0 Ver. 6.0	Ver. 7.0 or higher	
CS/CJ-series unit Ver. 4.0	Functions added for unit version 4.0	Using new functions	---	---	---	OK	No restrictions
		Not using new functions	OK	OK	OK	OK	
CS/CJ-series unit Ver. 3.0	Functions added for unit version 3.0	Using new functions	---	---	OK	OK	
		Not using new functions	OK	OK	OK	OK	
CS/CJ-series unit Ver. 2.0	Functions added for unit version 2.0	Using new functions	---	OK	OK	OK	
		Not using new functions	OK	OK	OK	OK	

Note As shown above, there is no need to upgrade to CX-Programmer version as long as the functions added for unit versions are not used.

Device Type Setting

The unit version does not affect the setting made for the device type on the CX-Programmer. Select the device type as shown in the following table regardless of the unit version of the CPU Unit.

Series	CPU Unit group	CPU Unit model	Device type setting on CX-Programmer Ver. 4.0 or higher
CJ Series	CJ1-H CPU Units	CJ1G-CPU□□□H	CJ1G-H
		CJ1G-CPU□□□P	
	CJ1H-CPU□□□H	CJ1H-H	
	CJ1M CPU Units	CJ1M-CPU□□	CJ1M

Troubleshooting Problems with Unit Versions on the CX-Programmer



Problem	Cause	Solution
 <p>After the above message is displayed, a compiling error will be displayed on the <i>Compile</i> Tab Page in the Output Window.</p>	An attempt was made to download a program containing instructions supported only by later unit versions or a CPU Unit to a previous unit version.	Check the program or change to a CPU Unit with a later unit version.
	An attempt was to download a PLC Setup containing settings supported only by later unit versions or a CPU Unit to a previous unit version.	Check the settings in the PLC Setup or change to a CPU Unit with a later unit version.
"???" is displayed in a program transferred from the PLC to the CX-Programmer.	An attempt was made to upload a program containing instructions supported only by higher versions of CX-Programmer to a lower version.	New instructions cannot be uploaded to lower versions of CX-Programmer. Use a higher version of CX-Programmer.

TABLE OF CONTENTS

PRECAUTIONS	xxvii
1 Intended Audience	xxviii
2 General Precautions	xxviii
3 Safety Precautions	xxviii
4 Operating Environment Precautions	xxx
5 Application Precautions	xxxi
6 Conformance to EC Directives	xxxiv
SECTION 1	
Features	1
1-1 Features	2
1-2 Version Upgrades for CJ1M CPU Units	5
1-3 Functions Listed by Purpose	6
SECTION 2	
Overview	11
2-1 Allocations for Built-in CPU Unit Inputs	12
2-2 Allocations for Built-in CPU Unit Outputs	15
2-3 Allocations for Origin Search Function	16
SECTION 3	
I/O Specifications and Wiring	19
3-1 I/O Specifications	20
3-2 Wiring	23
3-3 Wiring Examples	32
SECTION 4	
Data Area Allocation and PLC Setup Settings	51
4-1 Data Area Allocation for Built-in I/O	52
4-2 PLC Setup Settings	52
4-3 Auxiliary Area Data Allocation	68
4-4 Flag Operations during Pulse Output	76
SECTION 5	
High-speed Counter/Pulse Output Instructions	79
5-1 MODE CONTROL: INI(880)	80
5-2 HIGH-SPEED COUNTER PV READ: PRV(881)	83
5-3 COUNTER FREQUENCY CONVERT: PRV2(883)	90
5-4 REGISTER COMPARISON TABLE: CTBL(882)	93
5-5 SPEED OUTPUT: SPED(885)	98
5-6 SET PULSES: PULS(886)	102

TABLE OF CONTENTS

5-7	PULSE OUTPUT: PLS2(887)	104
5-8	ACCELERATION CONTROL: ACC(888)	111
5-9	ORIGIN SEARCH: ORG(889)	118
5-10	PULSE WITH VARIABLE DUTY FACTOR: PWM(891)	122
 SECTION 6		
Built-in I/O Function Descriptions		125
6-1	Built-in Inputs	126
6-2	Built-in Outputs	144
6-3	Origin Search and Origin Return Functions	169
 SECTION 7		
Programming Examples		191
7-1	Built-in Outputs	192
 Appendices		
A	Combinations of Pulse Control Instructions	221
B	Using Pulse Instructions in other CPU Units	225
C	Interrupt Response Times	229
 Index		231
 Revision History		237

About this Manual:

This manual describes the installation and operation of the CJ-series Programmable Controllers (PLCs) and includes the sections described on the following page. The CS Series and CJ Series are subdivided as shown in the following table.

Unit	CS Series	CJ Series
CPU Units	CS1-H CPU Units: CS1H-CPU□□H CS1G-CPU□□H	CJ1-H CPU Units: CJ1H-CPU□□H CJ1G-CPU□□H CJ1G-CPU□□P
	CS1 CPU Units: CS1H-CPU□□-EV1 CS1G-CPU□□-EV1	CJ1 CPU Units: CJ1G-CPU□□-EV1 CJ1M CPU Units: CJ1M-CPU□□
	CS1D CPU Units: CS1D CPU Units for Duplex-CPU System: CS1D-CPU□□H CS1D CPU Units for Single-CPU System: CS1D-CPU□□S CS1D Process CPU Units: CS1D-CPU□□P	
Basic I/O Units	CS-series Basic I/O Units	CJ-series Basic I/O Units
Special I/O Units	CS-series Special I/O Units	CJ-series Special I/O Units
CPU Bus Units	CS-series CPU Bus Units	CJ-series CPU Bus Units
Power Supply Units	CS-series Power Supply Units	CJ-series Power Supply Units

Please read this manual and all related manuals listed in the following table and be sure you understand information provided before attempting to install or use CJ-series CPU Units in a PLC System.

Name	Cat. No.	Contents
SYSMAC CJ Series CJ1M-CPU21/22/23 Built-in I/O Operation Manual	W395	Describes the functions of the built-in I/O for CJ1M CPU Units. (This manual)
SYSMAC CJ/NSJ Series CJ1G-CPU□□, CJ1M-CPU□□, CJ1G-CPU□□P, CJ1G/H-CPU□□H, NSJ□-□□□□(B)-G5D, NSJ□-□□□□(B)-M3D Programmable Controllers Operation Manual	W393	Provides an outlines of and describes the design, installation, maintenance, and other basic operations for the CJ-series PLCs.
SYSMAC CS/CJ/NSJ Series CS1G/H-CPU□□-EV1, CS1G/H-CPU□□H, CS1D-CPU□□H, CS1D-CPU□□S, CJ1G-CPU□□, CJ1M-CPU□□, CJ1G-CPU□□P, CJ1G/H-CPU□□H, NSJ□-□□□□(B)-G5D, NSJ□-□□□□(B)-M3D Programmable Controllers Programming Manual	W394	This manual describes programming and other methods to use the functions of the CS/CJ-series PLCs.
SYSMAC CS/CJ/NSJ Series CS1G/H-CPU□□-EV1, CS1G/H-CPU□□H, CS1D-CPU□□H, CS1D-CPU□□S, CJ1G-CPU□□, CJ1M-CPU□□, CJ1G-CPU□□P, CJ1G/H-CPU□□H, NSJ□-□□□□(B)-G5D, NSJ□-□□□□(B)-M3D Programmable Controllers Instructions Reference Manual	W340	Describes the ladder diagram programming instructions supported by CS/CJ-series PLCs.
SYSMAC CS/CJ Series CQM1H-PRO01-E, C200H-PRO27-E, CQM1-PRO01-E Programming Consoles Operation Manual	W341	Provides information on how to program and operate CS/CJ-series PLCs using a Programming Console.

About this Manual, Continued

Name	Cat. No.	Contents
SYSMAC CS/CJ/NSJ Series CS1G/H-CPU□□-EV1, CS1G/H-CPU□□H, CS1D-CPU□□H, CS1D-CPU□□S, CJ1G-CPU□□, CJ1M-CPU□□, CJ1G-CPU□□P, CJ1G/H-CPU□□H, CS1W-SCB□□-V1, CS1W-SCU□□-V1, CJ1W-SCU□□-V1, CP1H-X□□□□-□, CP1H-XA□□□□-□, CP1H-Y□□□□-□, Communications Commands Reference Manual	W342	Describes the C-series (Host Link) and FINS communications commands used with CS/CJ-series PLCs.
NSJ5-TQ□□(B)-G5D NSJ5-SQ□□(B)-G5D NSJ8-TV□□(B)-G5D NSJ10-TV□□(B)-G5D NSJ12-TS□□(B)-G5D NSJ5-TQ□□(B)-M3D NSJ5-SQ□□(B)-M3D NSJ8-TV□□(B)-M3D NSJ Series Operation Manual	W452	Provides the following information about the NSJ-series NSJ Controllers: Overview and features Designing the system configuration Installation and wiring I/O memory allocations Troubleshooting and maintenance Use this manual in combination with the following manuals: SYSMAC CS Series Operation Manual (W339), SYSMAC CJ Series Operation Manual (W393), SYSMAC CS/CJ Series Programming Manual (W394), and NS-V1/-V2 Series Setup Manual (V083)
SYSMAC WS02-CXPC1-E-V70 CX-Programmer Operation Manual	W446	Provides information on how to use the CX-Programmer for all functionality except for function blocks.
SYSMAC WS02-CXPC1-E-V7 CX-Programmer Ver. 7.0 Operation Manual Function Blocks (CS1G-CPU□□H, CS1H-CPU□□H, CJ1G-CPU□□H, CJ1H-CPU□□H, CJ1M-CPU□□, CP1H-X□□□□-□, CP1H-XA□□□□-□, CP1H-Y□□□□-□ CPU Units)	W447	Describes the functionality unique to the CX-Programmer Ver. 7.0 and CP-series CPU Units or CS/CJ-series CPU Units with unit version 3.0 or later based on function blocks. Functionality that is the same as that of the CX-Programmer is described in W446 (enclosed).
SYSMAC CS/CJ Series CS1W-SCB□□-V1, CS1W-SCU□□-V1, CJ1W-SCU□□-V1 Serial Communications Boards/Units Operation Manual	W336	Describes the use of Serial Communications Unit and Boards to perform serial communications with external devices, including the usage of standard system protocols for OMRON products.
SYSMAC WS02-PSTC1-E CX-Protocol Operation Manual	W344	Describes the use of the CX-Protocol to create protocol macros as communications sequences to communicate with external devices.
CXONE-AL□□C-EV2/ CXONE-AL□□D-EV2 CX-Integrator Ver. 2.0 Operation Manual	W464	Describes operating procedures for the CX-Integrator Network Configuration Tool for CS-, CJ-, CP-, and NSJ-series Controllers.
CXONE-AL□□C-EV2/AL□□D-EV2 CX-One Ver. 2.0 FA Integrated Tool Package Setup Manual	W463	Installation and overview of CX-One FA Integrated Tool Package.

This manual describes the installation and operation of the built-in I/O supported by the CJ1M-CPU21, CJ1M-CPU22, and CJ1M-CPU23 CPU Units and includes the sections described below.

Please read this manual carefully and be sure you understand the information provided before attempting to install or operate the built-in I/O. Be sure to read the precautions provided in the following section.

Precautions provides general precautions for using the CJ-series Programmable Controllers (PLCs) and related devices.

Section 1 describes the features and applications of the functions of the built-in I/O.

Section 2 provides an overview of the functions of built-in I/O.

Section 3 provides I/O specifications and wiring instructions for the built-in I/O.

Section 4 describes the allocation of words and bits for usage with the built-in I/O and PLC Setup settings related to built-in I/O.

Section 5 describes the allocation of words and bits for usage with the built-in I/O and PLC Setup settings related to built-in I/O.

Section 6 describes the application of built-in I/O in detail.

Section 7 provides examples of programming built-in I/O.

The **Appendices** provides a table shown which pulse control instructions can be used together, a table of pulse control instruction support in other PLCs, and instruction execution times.

 **WARNING** Failure to read and understand the information provided in this manual may result in personal injury or death, damage to the product, or product failure. Please read each section in its entirety and be sure you understand the information provided in the section and related sections before attempting any of the procedures or operations given.

Read and Understand this Manual

Please read and understand this manual before using the product. Please consult your OMRON representative if you have any questions or comments.

Warranty and Limitations of Liability

WARRANTY

OMRON's exclusive warranty is that the products are free from defects in materials and workmanship for a period of one year (or other period if specified) from date of sale by OMRON.

OMRON MAKES NO WARRANTY OR REPRESENTATION, EXPRESS OR IMPLIED, REGARDING NON-INFRINGEMENT, MERCHANTABILITY, OR FITNESS FOR PARTICULAR PURPOSE OF THE PRODUCTS. ANY BUYER OR USER ACKNOWLEDGES THAT THE BUYER OR USER ALONE HAS DETERMINED THAT THE PRODUCTS WILL SUITABLY MEET THE REQUIREMENTS OF THEIR INTENDED USE. OMRON DISCLAIMS ALL OTHER WARRANTIES, EXPRESS OR IMPLIED.

LIMITATIONS OF LIABILITY

OMRON SHALL NOT BE RESPONSIBLE FOR SPECIAL, INDIRECT, OR CONSEQUENTIAL DAMAGES, LOSS OF PROFITS OR COMMERCIAL LOSS IN ANY WAY CONNECTED WITH THE PRODUCTS, WHETHER SUCH CLAIM IS BASED ON CONTRACT, WARRANTY, NEGLIGENCE, OR STRICT LIABILITY.

In no event shall the responsibility of OMRON for any act exceed the individual price of the product on which liability is asserted.

IN NO EVENT SHALL OMRON BE RESPONSIBLE FOR WARRANTY, REPAIR, OR OTHER CLAIMS REGARDING THE PRODUCTS UNLESS OMRON'S ANALYSIS CONFIRMS THAT THE PRODUCTS WERE PROPERLY HANDLED, STORED, INSTALLED, AND MAINTAINED AND NOT SUBJECT TO CONTAMINATION, ABUSE, MISUSE, OR INAPPROPRIATE MODIFICATION OR REPAIR.

Application Considerations

SUITABILITY FOR USE

OMRON shall not be responsible for conformity with any standards, codes, or regulations that apply to the combination of products in the customer's application or use of the products.

At the customer's request, OMRON will provide applicable third party certification documents identifying ratings and limitations of use that apply to the products. This information by itself is not sufficient for a complete determination of the suitability of the products in combination with the end product, machine, system, or other application or use.

The following are some examples of applications for which particular attention must be given. This is not intended to be an exhaustive list of all possible uses of the products, nor is it intended to imply that the uses listed may be suitable for the products:

- Outdoor use, uses involving potential chemical contamination or electrical interference, or conditions or uses not described in this manual.
- Nuclear energy control systems, combustion systems, railroad systems, aviation systems, medical equipment, amusement machines, vehicles, safety equipment, and installations subject to separate industry or government regulations.
- Systems, machines, and equipment that could present a risk to life or property.

Please know and observe all prohibitions of use applicable to the products.

NEVER USE THE PRODUCTS FOR AN APPLICATION INVOLVING SERIOUS RISK TO LIFE OR PROPERTY WITHOUT ENSURING THAT THE SYSTEM AS A WHOLE HAS BEEN DESIGNED TO ADDRESS THE RISKS, AND THAT THE OMRON PRODUCTS ARE PROPERLY RATED AND INSTALLED FOR THE INTENDED USE WITHIN THE OVERALL EQUIPMENT OR SYSTEM.

PROGRAMMABLE PRODUCTS

OMRON shall not be responsible for the user's programming of a programmable product, or any consequence thereof.

Disclaimers

CHANGE IN SPECIFICATIONS

Product specifications and accessories may be changed at any time based on improvements and other reasons.

It is our practice to change model numbers when published ratings or features are changed, or when significant construction changes are made. However, some specifications of the products may be changed without any notice. When in doubt, special model numbers may be assigned to fix or establish key specifications for your application on your request. Please consult with your OMRON representative at any time to confirm actual specifications of purchased products.

DIMENSIONS AND WEIGHTS

Dimensions and weights are nominal and are not to be used for manufacturing purposes, even when tolerances are shown.

PERFORMANCE DATA

Performance data given in this manual is provided as a guide for the user in determining suitability and does not constitute a warranty. It may represent the result of OMRON's test conditions, and the users must correlate it to actual application requirements. Actual performance is subject to the OMRON Warranty and Limitations of Liability.

ERRORS AND OMISSIONS

The information in this manual has been carefully checked and is believed to be accurate; however, no responsibility is assumed for clerical, typographical, or proofreading errors, or omissions.

PRECAUTIONS

This section provides general precautions for using the CJ-series Programmable Controllers (PLCs) and related devices.

The information contained in this section is important for the safe and reliable application of Programmable Controllers. You must read this section and understand the information contained before attempting to set up or operate a PLC system.

1	Intended Audience	xxviii
2	General Precautions	xxviii
3	Safety Precautions	xxviii
4	Operating Environment Precautions	xxx
5	Application Precautions	xxxi
6	Conformance to EC Directives	xxxiv
6-1	Applicable Directives	xxxiv
6-2	Concepts	xxxiv
6-3	Conformance to EC Directives	xxxv
6-4	Relay Output Noise Reduction Methods	xxxv

1 Intended Audience

This manual is intended for the following personnel, who must also have knowledge of electrical systems (an electrical engineer or the equivalent).

- Personnel in charge of installing FA systems.
- Personnel in charge of designing FA systems.
- Personnel in charge of managing FA systems and facilities.

2 General Precautions

The user must operate the product according to the performance specifications described in the operation manuals.

Before using the product under conditions which are not described in the manual or applying the product to nuclear control systems, railroad systems, aviation systems, vehicles, combustion systems, medical equipment, amusement machines, safety equipment, and other systems, machines, and equipment that may have a serious influence on lives and property if used improperly, consult your OMRON representative.

Make sure that the ratings and performance characteristics of the product are sufficient for the systems, machines, and equipment, and be sure to provide the systems, machines, and equipment with double safety mechanisms.

This manual provides information for programming and operating the Unit. Be sure to read this manual before attempting to use the Unit and keep this manual close at hand for reference during operation.









 **WARNING** It is extremely important that a PLC and all PLC Units be used for the specified purpose and under the specified conditions, especially in applications that can directly or indirectly affect human life. You must consult with your OMRON representative before applying a PLC System to the above-mentioned applications.

3 Safety Precautions

 **WARNING** The CPU Unit refreshes I/O even when the program is stopped (i.e., even in PROGRAM mode). Confirm safety thoroughly in advance before changing the status of any part of memory allocated to I/O Units, Special I/O Units, or CPU Bus Units. Any changes to the data allocated to any Unit may result in unexpected operation of the loads connected to the Unit. Any of the following operation may result in changes to memory status.

- Transferring I/O memory data to the CPU Unit from a Programming Device.
- Changing present values in memory from a Programming Device.
- Force-setting/-resetting bits from a Programming Device.
- Transferring I/O memory files from a Memory Card or EM file memory to the CPU Unit.
- Transferring I/O memory from a host computer or from another PLC on a network.

 **WARNING** Do not attempt to take any Unit apart while the power is being supplied. Doing so may result in electric shock.

-  **WARNING** Do not touch any of the terminals or terminal blocks while the power is being supplied. Doing so may result in electric shock.
-  **WARNING** Do not attempt to disassemble, repair, or modify any Units. Any attempt to do so may result in malfunction, fire, or electric shock.
-  **WARNING** Do not touch the Power Supply Unit while power is being supplied or immediately after power has been turned OFF. Doing so may result in electric shock.
-  **WARNING** Provide safety measures in external circuits (i.e., not in the Programmable Controller), including the following items, to ensure safety in the system if an abnormality occurs due to malfunction of the PLC or another external factor affecting the PLC operation. Not doing so may result in serious accidents.
- Emergency stop circuits, interlock circuits, limit circuits, and similar safety measures must be provided in external control circuits.
 - The PLC will turn OFF all outputs when its self-diagnosis function detects any error or when a severe failure alarm (FALS) instruction is executed. As a countermeasure for such errors, external safety measures must be provided to ensure safety in the system.
 - The PLC outputs may remain ON or OFF due to deposition or burning of the output relays or destruction of the output transistors. As a countermeasure for such problems, external safety measures must be provided to ensure safety in the system.
 - When the 24-V DC output (service power supply to the PLC) is overloaded or short-circuited, the voltage may drop and result in the outputs being turned OFF. As a countermeasure for such problems, external safety measures must be provided to ensure safety in the system.
-  **Caution** Confirm safety before transferring data files stored in the file memory (Memory Card or EM file memory) to the I/O area (CIO) of the CPU Unit using a peripheral tool. Otherwise, the devices connected to the output unit may malfunction regardless of the operating mode of the CPU Unit.
-  **Caution** Fail-safe measures must be taken by the customer to ensure safety in the event of incorrect, missing, or abnormal signals caused by broken signal lines, momentary power interruptions, or other causes. Serious accidents may result from abnormal operation if proper measures are not provided.
-  **Caution** Execute online edit only after confirming that no adverse effects will be caused by extending the cycle time. Otherwise, the input signals may not be readable.
-  **Caution** Confirm safety at the destination node before transferring a program to another node or changing contents of the I/O memory area. Doing either of these without confirming safety may result in injury.

 **Caution** A CJ1M CPU Unit automatically back up the user program and parameter data to flash memory when these are written to the CPU Unit. I/O memory (including the DM, EM, and HR Areas), however, is not written to flash memory. The DM, EM, and HR Areas can be held during power interruptions with a battery. If there is a battery error, the contents of these areas may not be accurate after a power interruption. If the contents of the DM, EM, and HR Areas are used to control external outputs, prevent inappropriate outputs from being made whenever the Battery Error Flag (A40204) is ON. Areas such as the DM, EM, and HR Areas, the contents of which can be held during power interrupts, is backed up by a battery. If a battery error occurs, the contents of the areas that are set to be held may not be accurate even though a memory error will not occur to stop operation. If necessary for the safety of the system, take appropriate measures in the ladder program whenever the Battery Error Flag (A40204) turns ON, such as resetting the data in these areas.

 **Caution** Tighten the screws on the terminal block of the AC Power Supply Unit to the torque specified in the operation manual. The loose screws may result in burning or malfunction.

4 Operating Environment Precautions

 **Caution** Do not operate the control system in the following locations:

- Locations subject to direct sunlight.
- Locations subject to temperatures or humidity outside the range specified in the specifications.
- Locations subject to condensation as the result of severe changes in temperature.
- Locations subject to corrosive or flammable gases.
- Locations subject to dust (especially iron dust) or salts.
- Locations subject to exposure to water, oil, or chemicals.
- Locations subject to direct shock or vibration.

 **Caution** Take appropriate and sufficient countermeasures when installing systems in the following locations:

- Locations subject to static electricity or other forms of noise.
- Locations subject to strong electromagnetic fields.
- Locations subject to possible exposure to radioactivity.
- Locations close to power supplies or power lines.

 **Caution** The operating environment of the PLC System can have a large effect on the longevity and reliability of the system. Improper operating environments can lead to malfunction, failure, and other unforeseeable problems with the PLC System. Be sure that the operating environment is within the specified conditions at installation and remains within the specified conditions during the life of the system.

5 Application Precautions

Observe the following precautions when using the PLC System.

- You must use the CX-Programmer (programming software that runs on Windows) if you need to program more than one cyclic task. A Programming Console can be used to program only one cyclic task plus interrupt tasks. A Programming Console can, however, be used to edit multitask programs originally created with the CX-Programmer.

 **WARNING** Always heed these precautions. Failure to abide by the following precautions could lead to serious or possibly fatal injury.

- Always connect to a ground of 100 Ω or less when installing the Units. Not connecting to a ground of 100 Ω or less may result in electric shock.
- A ground of 100 Ω or less must be installed when shorting the GR and LG terminals on the Power Supply Unit.
- Always turn OFF the power supply to the PLC before attempting any of the following. Not turning OFF the power supply may result in malfunction or electric shock.
 - Mounting or dismounting Power Supply Units, I/O Units, CPU Units, or any other Units.
 - Assembling the Units.
 - Setting DIP switches or rotary switches.
 - Connecting cables or wiring the system.
 - Connecting or disconnecting the connectors.

 **Caution** Failure to abide by the following precautions could lead to faulty operation of the PLC or the system, or could damage the PLC or PLC Units. Always heed these precautions.

- A CJ-series CPU Unit is shipped with the battery installed and the time already set on the internal clock. It is not necessary to clear memory or set the clock before application, as it is for the CS-series CPU Units.
- The user program and parameter area data in CJ1M CPU Units is backed up in the built-in flash memory. The BKUP indicator will light on the front of the CPU Unit when the backup operation is in progress. Do not turn OFF the power supply to the CPU Unit when the BKUP indicator is lit. The data will not be backed up if power is turned OFF.
- If, when using a CJ1M CPU Unit, the PLC Setup is set to specify using the mode set on the Programming Console and a Programming Console is not connected, the CPU Unit will start in RUN mode. This is the default setting in the PLC Setup. (A CS1 CPU Unit will start in PROGRAM mode under the same conditions.)
- When creating an AUTOEXEC.IOM file from a Programming Device (a Programming Console or the CX-Programmer) to automatically transfer data at startup, set the first write address to D20000 and be sure that the size of data written does not exceed the size of the DM Area. When the data file is read from the Memory Card at startup, data will be written in the CPU Unit starting at D20000 even if another address was set when the AUTOEXEC.IOM file was created. Also, if the DM Area is exceeded (which is possible when the CX-Programmer is used), the remaining data will be written to the EM Area.

- Fail-safe measures must be taken by the customer to ensure safety in the event of incorrect, missing, or abnormal signals caused by broken signal lines, momentary power interruptions, or other causes.
- Interlock circuits, limit circuits, and similar safety measures in external circuits (i.e., not in the Programmable Controller) must be provided by the customer.
- Always turn ON power to the PLC before turning ON power to the control system. If the PLC power supply is turned ON after the control power supply, temporary errors may result in control system signals because the output terminals on DC Output Units and other Units will momentarily turn ON when power is turned ON to the PLC.
- Fail-safe measures must be taken by the customer to ensure safety in the event that outputs from Output Units remain ON as a result of internal circuit failures, which can occur in relays, transistors, and other elements.
- If the I/O Hold Bit is turned ON, the outputs from the PLC will not be turned OFF and will maintain their previous status when the PLC is switched from RUN or MONITOR mode to PROGRAM mode. Make sure that the external loads will not produce dangerous conditions when this occurs. (When operation stops for a fatal error, including those produced with the FALS(007) instruction, all outputs from Output Unit will be turned OFF and only the internal output status will be maintained.)
- The contents of the DM, EM, and HR Areas in the CPU Unit are backed up by a Battery. If the Battery voltage drops, this data may be lost. Provide countermeasures in the program using the Battery Error Flag (A40204) to re-initialize data or take other actions if the Battery voltage drops.
- Do not turn OFF the power supply to the PLC when data is being transferred. In particular, do not turn OFF the power supply when reading or writing a Memory Card. Also, do not remove the Memory Card when the BUSY indicator is lit. To remove a Memory Card, first press the memory card power supply switch and then wait for the BUSY indicator to go out before removing the Memory Card.
The Memory Card may become unusable if the power supply is turned OFF or the Card is removed while data is being transferred.
- Confirm that no adverse effect will occur in the system before attempting any of the following. Not doing so may result in an unexpected operation.
 - Changing the operating mode of the PLC (including changing the Startup Mode).
 - Force-setting/force-resetting any bit in memory.
 - Changing the present value of any word or any set value in memory.
- Install external safety measures against short-circuiting such as circuit breakers in external wiring. Insufficient safety measures against short-circuiting may result in burning.
- Install the Units as far as possible from devices that generate strong, high-frequency noise.
- Be sure that all the terminal screws, and cable connector screws are tightened to the torque specified in the relevant manuals. Incorrect tightening torque may result in malfunction.
- Mount Units only after checking terminal blocks and connectors completely.
- Before touching a Unit, be sure to first touch a grounded metallic object in order to discharge any static build-up. Not doing so may result in malfunction or damage.

- Be sure that the terminal blocks, Memory Units, expansion cables, and other items with locking devices are properly locked into place. Improper locking may result in malfunction.
- Wire all connections correctly.
- Always use the power supply voltages specified in the operation manuals. An incorrect voltage may result in malfunction or burning.
- Take appropriate measures to ensure that the specified power with the rated voltage and frequency is supplied. Be particularly careful in places where the power supply is unstable. An incorrect power supply may result in malfunction.
- Leave the label attached to the Unit when wiring. Removing the label may result in malfunction if foreign matter enters the Unit.
- Remove the label after the completion of wiring to ensure proper heat dissipation. Leaving the label attached may result in malfunction.
- Use crimp terminals for wiring. Do not connect bare stranded wires directly to terminals. Connection of bare stranded wires may result in burning.
- Do not apply voltages to the Input Units in excess of the rated input voltage. Excess voltages may result in burning.
- Do not apply voltages or connect loads to the Output Units in excess of the maximum switching capacity. Excess voltage or loads may result in burning.
- Always connect to a ground of 100 Ω or less when installing the Units, particularly when shorting the LG and GR terminals on the Power Supply Unit.
- Disconnect the LG and GR terminals when performing withstand voltage tests or insulation resistance tests.
- Do not drop the Units or subject them to abnormal vibration or shock.
- Double-check all wiring and switch settings before turning ON the power supply. Incorrect wiring may result in burning.
- Check switch settings, the contents of the DM Area, and other preparations before starting operation. Starting operation without the proper settings or data may result in an unexpected operation.
- Check the user program for proper execution before actually running it on the Unit. Not checking the program may result in an unexpected operation.
- Resume operation only after transferring to the new CPU Unit the contents of the DM Area, HR Area, and other data required for resuming operation. Not doing so may result in an unexpected operation.
- Do not pull on the cables or bend the cables beyond their natural limit. Doing either of these may break the cables.
- Do not place objects on top of the cables or other wiring lines. Doing so may break the cables.
- Do not use standard retail RS-232C personal computer cables. Always use the special cables listed in this manual or make cables according to manual specifications. Using standard, commercially available cables may damage the external devices or CPU Unit.
- When replacing parts, be sure to confirm that the rating of a new part is correct. Not doing so may result in malfunction or burning.

- When transporting or storing circuit boards, cover them in antistatic material to protect them from static electricity and maintain the proper storage temperature.
- Do not touch circuit boards or the components mounted to them with your bare hands. There are sharp leads and other parts on the boards that may cause injury if handled improperly.
- Do not short the battery terminals or charge, disassemble, heat, or incinerate the battery. Do not subject the battery to strong shocks. Doing any of these may result in leakage, rupture, heat generation, or ignition of the battery. Dispose of any battery that has been dropped on the floor or otherwise subjected to excessive shock. Batteries that have been subjected to shock may leak if they are used.
- UL standards require that batteries be replaced only by experienced technicians. Do not allow unqualified persons to replace batteries.
- Dispose of the Units and batteries according to local ordinances as they apply. Have qualified specialists properly dispose of used batteries as industrial waste.



廢電池請回收

- After connecting Power Supply Units, CPU Units, I/O Units, Special I/O Units, or CPU Bus Units together, secure the Units by sliding the sliders at the top and bottom of the Units until they click into place. Correct operation may not be possible if the Units are not securely properly. Be sure to attach the end cover provided with the CPU Unit to the rightmost Unit. CJ-series PLCs will not operate properly if the end cover is not attached.
- Incorrect data link table or parameter settings may cause unexpected operation. Even when the data link table and parameters have been set correctly, do not start or stop the data link before verifying that it is safe to do so.
- CPU Bus Units will be reset when the routing table is transferred from a Programming Device to the PLC. (The Units are reset to ensure that the new routing table data is read and enabled.) Do not transfer the routing table before verifying that it is safe to do so, i.e., it is safe for the CPU Bus Units to be reset.
- Install the Units properly as specified in the operation manuals. Improper installation of the Units may result in malfunction.

6 Conformance to EC Directives

6-1 Applicable Directives

- EMC Directives
- Low Voltage Directive

6-2 Concepts

EMC Directives

OMRON devices that comply with EC Directives also conform to the related EMC standards so that they can be more easily built into other devices or the overall machine. The actual products have been checked for conformity to EMC standards (see the following note). Whether the products conform to the standards in the system used by the customer, however, must be checked by the customer.

EMC-related performance of the OMRON devices that comply with EC Directives will vary depending on the configuration, wiring, and other conditions of the equipment or control panel on which the OMRON devices are installed. The customer must, therefore, perform the final check to confirm that devices and the overall machine conform to EMC standards.

Note Applicable EMC (Electromagnetic Compatibility) standards are as follows:

EMS (Electromagnetic Susceptibility): EN61000-6-2
EMI (Electromagnetic Interference): EN61000-6-4
(Radiated emission: 10-m regulations)

Low Voltage Directive

Always ensure that devices operating at voltages of 50 to 1,000 V AC and 75 to 1,500 V DC meet the required safety standards for the PLC (EN61131-2).

6-3 Conformance to EC Directives

The CJ-series PLCs comply with EC Directives. To ensure that the machine or device in which the CJ-series PLC is used complies with EC Directives, the PLC must be installed as follows:

- 1,2,3...**
1. The CJ-series PLC must be installed within a control panel.
 2. You must use reinforced insulation or double insulation for the DC power supplies used for the communications power supply and I/O power supplies.
 3. CJ-series PLCs complying with EC Directives also conform to the Common Emission Standard (EN61000-6-4). Radiated emission characteristics (10-m regulations) may vary depending on the configuration of the control panel used, other devices connected to the control panel, wiring, and other conditions. You must therefore confirm that the overall machine or equipment complies with EC Directives.

6-4 Relay Output Noise Reduction Methods

The CJ-series PLCs conforms to the Common Emission Standards (EN61000-6-4) of the EMC Directives. However, noise generated by relay output switching may not satisfy these Standards. In such a case, a noise filter must be connected to the load side or other appropriate countermeasures must be provided external to the PLC.

Countermeasures taken to satisfy the standards vary depending on the devices on the load side, wiring, configuration of machines, etc. Following are examples of countermeasures for reducing the generated noise.

Countermeasures

(Refer to EN61000-6-4 for more details.)

Countermeasures are not required if the frequency of load switching for the whole system with the PLC included is less than 5 times per minute.

Countermeasures are required if the frequency of load switching for the whole system with the PLC included is more than 5 times per minute.

Countermeasure Examples

When switching an inductive load, connect a surge protector, diodes, etc., in parallel with the load or contact as shown below.

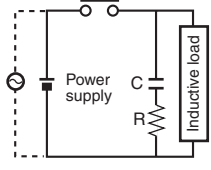
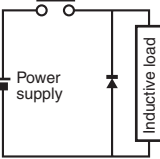
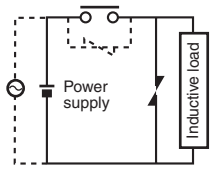
Circuit	Current		Characteristic	Required element
	AC	DC		
	Yes	Yes	<p>If the load is a relay or solenoid, there is a time lag between the moment the circuit is opened and the moment the load is reset.</p> <p>If the supply voltage is 24 or 48 V, insert the surge protector in parallel with the load. If the supply voltage is 100 to 200 V, insert the surge protector between the contacts.</p>	<p>The capacitance of the capacitor must be 1 to 0.5 μF per contact current of 1 A and resistance of the resistor must be 0.5 to 1 Ω per contact voltage of 1 V. These values, however, vary with the load and the characteristics of the relay. Decide these values from experiments, and take into consideration that the capacitance suppresses spark discharge when the contacts are separated and the resistance limits the current that flows into the load when the circuit is closed again.</p> <p>The dielectric strength of the capacitor must be 200 to 300 V. If the circuit is an AC circuit, use a capacitor with no polarity.</p>
	No	Yes	<p>The diode connected in parallel with the load changes energy accumulated by the coil into a current, which then flows into the coil so that the current will be converted into Joule heat by the resistance of the inductive load.</p> <p>This time lag, between the moment the circuit is opened and the moment the load is reset, caused by this method is longer than that caused by the CR method.</p>	<p>The reversed dielectric strength value of the diode must be at least 10 times as large as the circuit voltage value. The forward current of the diode must be the same as or larger than the load current.</p> <p>The reversed dielectric strength value of the diode may be two to three times larger than the supply voltage if the surge protector is applied to electronic circuits with low circuit voltages.</p>
	Yes	Yes	<p>The varistor method prevents the imposition of high voltage between the contacts by using the constant voltage characteristic of the varistor. There is time lag between the moment the circuit is opened and the moment the load is reset.</p> <p>If the supply voltage is 24 or 48 V, insert the varistor in parallel with the load. If the supply voltage is 100 to 200 V, insert the varistor between the contacts.</p>	---

When switching a load with a high inrush current such as an incandescent lamp, suppress the inrush current as shown below.

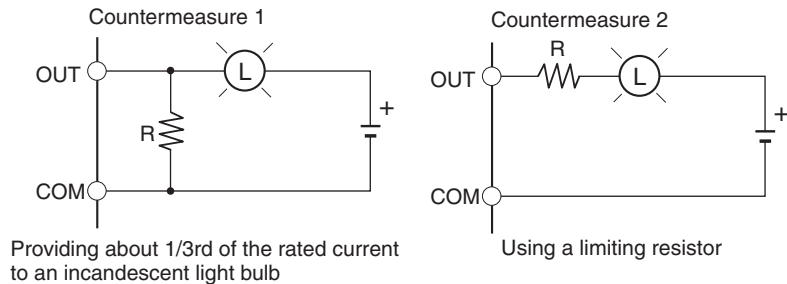

SECTION 1

Features

This section describes the features and applications of the functions of the built-in I/O.

1-1	Features	2
1-1-1	Built-in I/O Functions.	2
1-1-2	Configuration of the Built-in I/O Functions	4
1-2	Version Upgrades for CJ1M CPU Units	5
1-2-1	Improved Functionality of CJ1M CPU Units with Unit Version 3.0	5
1-2-2	Improved Functionality of CJ1M CPU Units with Unit Version 2.0	5
1-3	Functions Listed by Purpose	6
1-3-1	High-speed Processing	6
1-3-2	Controlling Pulse Outputs.	7
1-3-3	Receiving Pulse Inputs	9
1-3-4	Comparison with CJ1W-NC Pulse Outputs	10

1-1 Features

1-1-1 Built-in I/O Functions

The CJ1M CPU Units are high-speed, advanced, micro-sized PLCs equipped with built-in I/O. The built-in I/O have the following features.

General-purpose I/O

Immediate Refreshing

The CPU Unit's built-in inputs and outputs can be used as general-purpose inputs and outputs. In particular, immediate I/O refreshing can be performed on the I/O in the middle of a PLC cycle when a relevant instruction is executed.

Stabilizing Input Filter Function

The input time constant for the CPU Unit's 10 built-in inputs can be set to 0 ms (no filter), 0.5 ms, 1 ms, 2 ms, 4 ms, 8 ms, 16 ms, or 32 ms. Chattering and the effects of external noise can be reduced by increasing the input time constant.

Interrupt Inputs

High-speed Interrupt Input Processing

The CPU Unit's 10 built-in inputs can be used for high-speed processing as regular interrupt inputs in direct mode or interrupt inputs in counter mode. An interrupt task can be started at the interrupt input's rising or falling edge (up or down differentiation.) In counter mode, the interrupt task can be started when the input count reaches the set value (up-differentiated or down-differentiated transitions.)

High-speed Counters

High-speed Counter Function

A rotary encoder can be connected to a built-in input to accept high-speed counter inputs.

Trigger Interrupts at a Target Value or in a Specified Range

Interrupts can be triggered when the high-speed counter's PV matches a target value or is within a specified range.

Measure the Frequency of High-speed Counter Inputs

The PRV(881) instruction can be used to measure the input pulse frequency (one input only.)

Maintain or Refresh (Selectable) High-speed Counter PVs

The High-speed Counter Gate Bit can be turned ON/OFF from the ladder program to select whether the high-speed counter PVs will be maintained or refreshed.

Pulse Outputs

Fixed duty ratio pulses can be output from the CPU Unit's built-in outputs to perform positioning or speed control with a servo driver that accepts pulse inputs.

CW/CCW Pulse Outputs or Pulse + Direction Outputs

The pulse output mode can be set to match the motor driver's pulse input specifications.

Automatic Direction Selection for Easy Positioning with Absolute Coordinates

When operating in absolute coordinates (origin defined or PV changed with the INI(880) instruction), the CW/CCW direction will be selected automatically when the pulse output instruction is executed. (The CW/CCW direction is selected by determining whether the number of pulses specified in the instruction is greater than or less than the pulse output PV.)

Triangular Control

Triangular control (trapezoidal control without a constant-speed plateau) will be performed during positioning executed by an ACC(888) instruction (independent) or PLS2(887) instruction if the number of output pulses required for acceleration/deceleration exceeds the specified target pulse Output Amount. (The number of pulses required for acceleration/deceleration equals the time required to reach the target frequency x the target frequency.)

Previously, an error would have occurred under these conditions and the instruction would not have been executed.

Change Target Position During Positioning (Multiple Start)

When positioning was started with a PULSE OUTPUT (PLS2(887)) instruction and the positioning operation is still in progress, another PLS2(887) instruction can be executed to change the target position, target speed, acceleration rate, and deceleration rate.

Switch from Speed Control to Positioning (Fixed Distance Feed Interrupt)

A PLS2(887) instruction can be executed during a speed control operation to change to positioning mode. This feature allows a fixed distance feed interrupt (moving a specified amount) to be executed when specific conditions occur.

Change Target Speed and Acceleration/Deceleration Rate during Acceleration or Deceleration

When trapezoidal acceleration/deceleration is being executed according to a pulse output instruction (speed control or positioning), the target speed and acceleration/deceleration rate can be changed during acceleration or deceleration.

Use Variable Duty Ratio Pulse Outputs for Lighting, Power Control, Etc.

The PULSE WITH VARIABLE DUTY RATIO instruction (PWM(891)) can be used to output variable duty ratio pulses from the CPU Unit's built-in outputs for applications such as lighting and power control.

Origin Search**Use a Single Instruction for Origin Search and Origin Return Operations**

A precise origin search can be executed with one instruction that uses various I/O signals, such as the Origin Proximity Input Signal, Origin Input Signal, Positioning Completed Signal, and Error Counter Reset Output.

Also, an origin return operation can be performed to move directly to the established origin.

Quick-response Inputs**Receive Input Signals Shorter than the Cycle Time**

With quick-response inputs, inputs to the CPU Unit's built-in inputs (4 inputs max.) with an input signal width as short as 30 μ s can be received reliably regardless of the cycle time.

1-1-2 Configuration of the Built-in I/O Functions

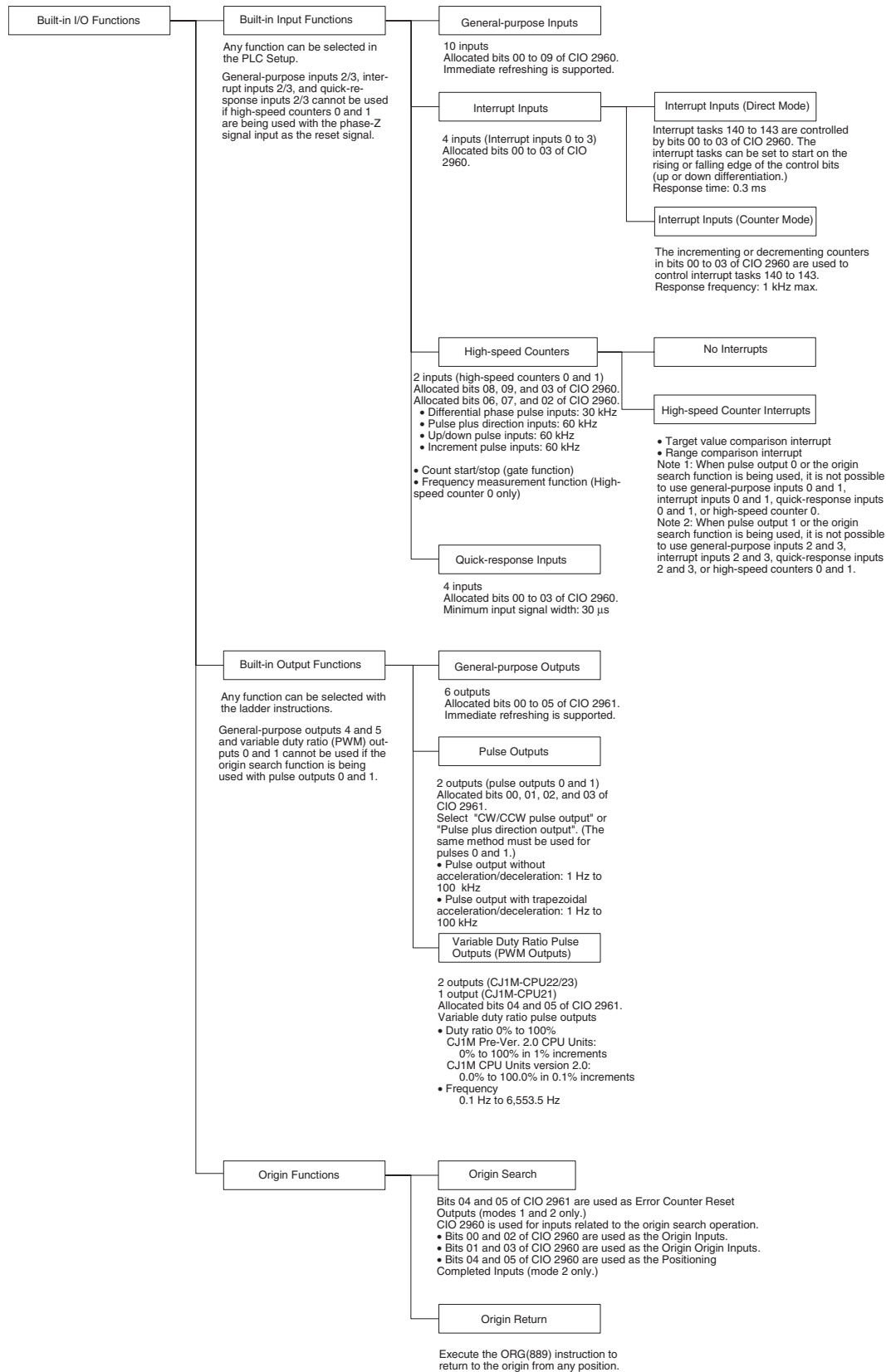

1-2 Version Upgrades for CJ1M CPU Units

This section describes the upgrades accompanying unit version 3.0 of the CJ1M CPU Units.

1-2-1 Improved Functionality of CJ1M CPU Units with Unit Version 3.0

The following improvements have been made in the upgrade from unit version 2.0 to unit version 3.0 of the CJ1M CPU Units. (Version upgrade information common to CJ Series is not included.)

High Frequency Calculation with PRV(881) and PRV2(883)

High-frequency calculation methods have been added to the pulse frequency calculation methods for PRV(881) (HIGH-SPEED COUNTER PV READ) and PRV2(883) (PULSE FREQUENCY CONVERT) instructions.

Reading Pulse Output Frequency with PRV(881) and PRV2(883)

The PRV(881) (HIGH-SPEED COUNTER PV READ) instruction can be used to read the pulse output frequency.

1-2-2 Improved Functionality of CJ1M CPU Units with Unit Version 2.0

The following improvements have been made in the upgrade to unit version 2.0 of the CJ1M CPU Units. (Version upgrade information common to CJ Series is not included.)

Pulse Outputs

S-curve Accelerations/Decelerations

S-curves can be specified for the acceleration/deceleration rates for Pulse Output Instructions with accelerations/decelerations (ACC(888), PLS2(883), and ORG(889)). When there is leeway in the maximum allowable speed, S-curve accelerations/decelerations will help control shock and vibration by reducing the initial acceleration rate in comparison with linear acceleration/deceleration.

Expanded Acceleration/Deceleration Rate Setting

The upper limit of the acceleration/deceleration rate has been increased from 2,000 Hz to 65,535 Hz for Pulse Output Instructions with accelerations/decelerations (ACC(888), PLS2(883), and ORG(889)).

Duty Ratios Set in 0.1% Increments

The duty ratio for PWM(891) can now be set in 0.1% increments. The duty ratio was set in 1% increments for the previous version.

Wider Range of Applications for CW/CCW Limit Inputs

Pulse outputs will stop when the CW/CCW limit input signals (reflected in A54008, A54009, A54108, and A54109) turn ON. For the previous version, the CW/CCW limit input signals were used only by ORG(889). With CPU Unit Ver. 2.0, these signals can now be used with pulse output functions other than origin searches. A new setting is also available for all functions that use the CW/CCW limit input signals to specify whether the origin will remain established or be undefined when a limit input signal turns ON.

Pulse Inputs

Pulse Frequency Conversions

The pulse frequency input to high-speed counter 0 can be converted to a rotational speed (r/min) or the PV of the counter can be converted to the total number of rotations.

High-speed Counters

Count Direction Flag

The Count Direction Flag enables monitoring whether the count of the high-speed counter is currently being incremented or decremented. The count in the current cycle is compared with the count in the previous cycle to determine whether it is being incremented or decremented.

Continued Comparisons when Resetting Counters

The comparison operation can be set to stop or continue when a high-speed counter is reset. This enables applications where the comparison operation can be restarted from a counter PV of 0 when the counter is reset. For the previous version, the comparison operation stopped when the counter was reset, requiring that the comparison operation be restarted from the ladder program whenever resetting the counter.

1-3 Functions Listed by Purpose

1-3-1 High-speed Processing

Purpose	I/O used	Function		Description
Execute a special process very quickly when the corresponding input goes ON (up differentiation) or OFF (down differentiation). (For example, operating a cutter when an interrupt input is received from a Proximity Sensor or Photoelectric Sensor.)	Built-in Inputs	Interrupt inputs 0 to 3	Interrupt inputs (Direct mode)	Executes an interrupt task at the rising or falling edge of the corresponding built-in input (CIO 2960 bits 00 to 03). Use the MSKS(690) instruction to specify up or down differentiation and unmask the interrupt.
Count the input signals and execute a special process very quickly when the count reaches the preset value. (For example, stopping the supply feed when a preset number of workpieces have passed through the system.)	Built-in Inputs	Interrupt inputs 0 to 3	Interrupt inputs (Counter mode)	Decrements the PV for each rising or falling edge signal at the built-in input (CIO 2960 bits 00 to 03) and executes the corresponding interrupt task when the count reaches 0. (The counter can also be set to increment up to a preset SV.) Use the MSKS(690) instruction to refresh the counter mode SV and unmask the interrupt.
Execute a special process at a preset count value. (For example, cutting material very precisely at a given length.)	Built-in Inputs	High-speed counters 0 and 1	High-speed counter interrupt (Target value comparison)	Executes an interrupt task when the high-speed counter's PV matches a target value in the registered table. Use the CTBL(882) or INI(880) instruction to start target value comparison.
Execute a special process when the count is within a preset range. (For example, sorting material very quickly when it is within a given length range.)	Built-in Inputs	High-speed counters 0 and 1	High-speed counter interrupt (Range comparison)	Executes an interrupt task when the high-speed counter's PV is within a certain range in the registered table. Use the CTBL(882) or INI(880) instruction to start range comparison.
Reliably read pulses with an ON time shorter than the cycle time, such as inputs from a photomicrosensor.	Built-in Inputs	Quick-response inputs 0 to 3	Quick-response inputs	Reads pulses with an ON time shorter than the cycle time (as short as 30 μs) and keeps the corresponding bit in I/O memory ON for one cycle. Use the PLC Setup to enable the quick-response function for a built-in input (CIO 2960 bits 0 to 3).

1-3-2 Controlling Pulse Outputs

Purpose	I/O used	Function	Description
Perform simple positioning by outputting pulses to a motor driver that accepts pulse-train inputs.	Built-in Outputs	Pulse outputs 0 and 1 <ul style="list-style-type: none"> Single-phase pulse output without acceleration/deceleration Controlled by SPED. Single-phase pulse output with acceleration/deceleration (equal acceleration and deceleration rates for trapezoidal form) Controlled by ACC. Single-phase pulse output with trapezoidal for (Supports a startup frequency and different acceleration /deceleration rates.) Controlled by PLS2(887). 	The built-in outputs (bits 00 to 03 of CIO 2961) can be used as pulse outputs 0 and 1. Target frequency: 0 Hz to 100 kHz Duty ratio: 50% The pulse output mode can be set to CW/CCW pulse control or Pulse plus direction control, but the same output mode must be used for pulse outputs 0 and 1. Note The PV for pulse output 0 is stored in A276 and A277. The PV for pulse output 1 is stored in A278 and A279.
Perform origin search and origin return operations.	Built-in Outputs	Pulse outputs 0 and 1	Origin functions (Origin search and origin return) <ul style="list-style-type: none"> Origin search: To start the origin search, set the PLC Setup to enable the origin search operation, set the various origin search parameters, and execute the ORIGIN SEARCH instruction (ORG(889)). The Unit will determine the location of the origin based on the Origin Proximity Input Signal and Origin Input Signal. The coordinates of the pulse output's PV will automatically be set as the absolute coordinates. Origin return: To return to the predetermined origin, set the various origin return parameters and execute the ORIGIN SEARCH instruction (ORG(889)).
Change the target position during positioning. (For example, perform an emergency avoid operation with the Multiple Start feature.)	Built-in Outputs	Pulse outputs 0 and 1	Positioning with the PLS2(887) instruction When a positioning operation started with the PULSE OUTPUT (PLS2(887)) instruction is in progress, another PLS2(887) instruction can be executed to change the target position, target speed, acceleration rate, and deceleration rate.
Change speed in steps (polyline approximation) during speed control.	Built-in Outputs	Pulse outputs 0 and 1	Use the ACC(888) instruction (continuous) to change the acceleration rate or deceleration rate. When a speed control operation started with the ACC(888) instruction (continuous) is in progress, another ACC(888) instruction (continuous) can be executed to change the acceleration rate or deceleration rate.
Change speed in steps (polyline approximation) during positioning.	Built-in Outputs	Pulse outputs 0 and 1	Use the ACC(888) instruction (independent) or PLS2(887) to change the acceleration rate or deceleration rate. When a positioning operation started with the ACC(888) instruction (independent) or PLS2(887) instruction is in progress, another ACC(888) (independent) or PLS2(887) instruction can be executed to change the acceleration rate or deceleration rate.

Purpose	I/O used	Function	Description
Perform fixed distance feed interrupt.	Built-in Outputs	Pulse outputs 0 and 1	Execute positioning with the PLS2(887) instruction during an operation started with SPED(885) (continuous) or ACC(888) (continuous). When a speed control operation started with the SPED(885) instruction (continuous) or ACC(888) instruction (continuous) is in progress, the PLS2(887) instruction can be executed to switch to positioning, output a fixed number of pulses, and stop.
After determining the origin, perform positioning simply in absolute coordinates without regard to the direction of the current position or target position.	Built-in Outputs	Pulse outputs 0 and 1	The positioning direction is selected automatically in the absolute coordinate system. When operating in absolute coordinates (with the origin determined or INI(880) instruction executed to change the PV), the CW or CCW direction is selected automatically based on the relationship between the pulse output PV and the pulse Output Amount specified when the pulse output instruction is executed.
Perform triangular control.	Built-in Outputs	Pulse outputs 0 and 1	Positioning with the ACC(888) instruction (independent) or PLS2(887) instruction. When a positioning operation started with the ACC(888) instruction (independent) or PLS2(887) instruction is in progress, triangular control (trapezoidal control without the constant-speed plateau) will be performed if the number of output pulses required for acceleration/deceleration exceeds the specified target pulse Output Amount. (The number of pulses required for acceleration/deceleration equals the time required to reach the target frequency x the target frequency.)
Use variable duty ratio outputs for time-proportional temperature control.	Built-in Outputs	PWM(891) outputs 0 and 1 (See note.)	Control with analog inputs and the variable duty ratio pulse output function (PWM(891)) Two of the built-in outputs (bits 04 and 05 of CIO 2961) can be used as PWM(891) outputs 0 and 1 by executing the PWM(891) instruction.

Note PWM(891) output 1 is not supported by the CJ1M-CPU21.

1-3-3 Receiving Pulse Inputs

Purpose	I/O used	Function		Description
Receive incremental rotary encoder inputs to calculate length or position.				
<ul style="list-style-type: none"> Counting at low-speed frequencies (1 kHz max.) 	Built-in Inputs	Interrupt inputs 0 to 3	Interrupt inputs (Counter mode) Max. count frequency of 1 kHz (single-phase pulses only) in increment mode or decrement mode	Built-in inputs (bits 00 to 03 of CIO 2960) can be used as counter inputs. The interrupt inputs must be set to counter mode. The PVs for interrupt inputs 0 through 3 are stored in A536 through A539, respectively.
<ul style="list-style-type: none"> Counting at high-speed frequencies (30 kHz or 60 kHz max.) 	Built-in Inputs	High-speed counters 0 and 1	High-speed counter functions <ul style="list-style-type: none"> Differential phase input (4x multiplication) 30 kHz (50 kHz) Pulse + direction input 60 kHz (100 kHz) Up/down pulse input 60 kHz (100 kHz) Increment input 60 kHz (100 kHz) Note The figures in parentheses are for line driver inputs.	Built-in inputs (bits 02, 03, and 06 to 09 of CIO 2960) can be used as high-speed counter inputs. The PV for high-speed counter 0 is stored in A270 and A271. The PV for high-speed counter 1 is stored in A272 and A273. The counters can be operated in ring mode or linear mode.
Measure a workpiece's length or position. (Start counting when a certain condition is established or pause counting when a certain condition is established.)	Built-in Inputs	High-speed counters 0 and 1	High-speed Counter Gate Bits (bits A53108 and A53109)	The high-speed counter can be started or stopped (PV held) from the Unit's program by turning ON/OFF the High-speed Counter Gate Bits (bits A53108 and A53109) when the desired conditions are met.
Measure a workpiece's speed from its position data (frequency measurement.)	Built-in Inputs	High-speed counter 0	PRV(881) HIGH-SPEED COUNTER PV READ	The PRV(881) instruction can be used to measure the pulse frequency. <ul style="list-style-type: none"> Range with differential phase inputs: 0 to 50 kHz Range with all other input modes: 0 to 100 kHz
			PRV2(883) PULSE FREQUENCY CONVERT	PRV2(883) read the pulse frequency and converts it to a rotational speed (r/min) or it converts the counter PV to a total number of rotations. Results are calculated by the number of pulses/rotation.

1-3-4 Comparison with CJ1W-NC Pulse Outputs

Item		CJ1M	CJ1W-NC Position Control Unit
Control method		Controlled with the ladder program's Pulse Output instructions (SPED(885), ACC(888), and PLS2(887)).	Controlled with the Start Command Bit (Relative Movement Command Bit or Absolute Movement Command Bit).
Changing the speed during positioning		When the SPED(885) instruction (independent), ACC(888) instruction (independent), or PLS2(887) instruction is in progress, each instruction can be executed again to change the speed.	Override
Changing the speed during speed control		When the SPED(885) instruction (continuous) or ACC(888) instruction (continuous) is in progress, each instruction can be executed again to change the speed.	Override
Jog operation		External inputs can be used in the ladder program to start and stop operation with the ACC(888) instruction (continuous) and SPED(885) instruction (continuous).	Controlled with the Jog Start Bit, Jog Stop Bit, and Direction Specification Bit.
Origin search		Controlled with the ladder program's ORG(889) instruction.	Performed with the Origin Search Bit.
Origin return		Controlled with the ladder program's ORG(889) instruction.	Performed with the Origin Return Bit.
Teaching		Not supported.	Performed with the Teaching Start Bit.
Fixed distance feed interrupt (Continuous output with positioning)		Execute positioning with the PLS2(887) instruction during a speed control operation started with SPED(885) (continuous) or ACC(888) (continuous).	Performed with the Fixed Distance Feed Interrupt Start Bit.
Change the target position during positioning. (Multiple Start)		When a PLS2(887) instruction is being executed, another PLS2(887) instruction can be started.	Performed with the Start Command Bit (Relative Movement Command Bit or Absolute Movement Command Bit) during direct operation.
Decelerate to a stop during positioning.		Execute an ACC(888) (independent) instruction during a positioning operation started with ACC(888) (independent) or PLS2(887).	Performed with the Decelerate to Stop Bit.
Decelerate to a stop during speed control.		Execute an ACC(888) (continuous) instruction during a speed control operation started with SPED(885) (continuous) or ACC(888) (continuous).	Performed with the Decelerate to Stop Bit.
External I/O	Origin Input Signal	A built-in input is used.	Input through the Position Control Unit's input terminal.
	Origin Proximity Input Signal	A built-in input is used.	Input through the Position Control Unit's input terminal.
	Positioning Completed Signal	A built-in input is used.	Input through the Position Control Unit's input terminal.
	Error Counter Reset Output	A built-in output is used.	Output through the Position Control Unit's output terminal.
	CW/CCW Limit Input	A separate Input Unit is used and an Auxiliary Area bit is controlled from the program.	Input through the Position Control Unit's input terminal.

SECTION 2

Overview

This section provides an overview of the functions of built-in I/O.

2-1	Allocations for Built-in CPU Unit Inputs	12
2-2	Allocations for Built-in CPU Unit Outputs.	15
2-3	Allocations for Origin Search Function	16

2-1 Allocations for Built-in CPU Unit Inputs

Select 1) General-purpose inputs, 2) Interrupt inputs, 3) Quick-response inputs, or 4) High-speed counters with the PLC Setup. Inputs IN0 to IN3 can each be set to 1) General-purpose inputs, 2) Interrupt inputs, or 3) Quick-response inputs with the input operation settings. The listed inputs can be set for high speed counter operation with the high-speed counter operation settings. If an input is set for both input operation and high-speed counter operation, the high-speed counter operation setting will override the input operation setting.

PLC Setup			The functions of IN0 to IN3 are set with the input operation setting.			High-speed counter operation setting	Pulse output's origin search function enabled	Priority of PLC Setup settings
Address	Code		1) General-purpose inputs	2) Interrupt inputs	3) Quick-response inputs	4) High-speed counters	Inputs for origin search	
CIO 2960	Bit 00	IN0	General-purpose input 0	Interrupt input 0	Quick-response input 0		Origin search 0 (Origin Input Signal)	Origin search enable setting > Input operation settings
	Bit 01	IN1	General-purpose input 1	Interrupt input 1	Quick-response input 1		Origin search 0 (Origin Proximity Input Signal)	
	Bit 02	IN2	General-purpose input 2	Interrupt input 2	Quick-response input 2	High-speed counter 1 (Phase-Z/Reset)	Origin search 1 (Origin Input Signal)	Origin search enable setting > High-speed counter operation settings > Input operation settings
	Bit 03	IN3	General-purpose input 3	Interrupt input 3	Quick-response input 3	High-speed counter 0 (Phase-Z/Reset)	Origin search 1 (Origin Proximity Input Signal)	
	Bit 04	IN4	General-purpose input 4				Origin search 0 (Positioning Completed Signal)	
	Bit 05	IN5	General-purpose input 5				Origin search 1 (Positioning Completed Signal)	
	Bit 06	IN6	General-purpose input 6			High-speed counter 1 (Phase-A, Increment, or Count input)		High-speed counter operation settings > Input operation settings
	Bit 07	IN7	General-purpose input 7			High-speed counter 1 (Phase-B, Decrement, or Direction input)		
	Bit 08	IN8	General-purpose input 8			High-speed counter 0 (Phase-A, Increment, or Count input)		
	Bit 09	IN9	General-purpose input 9			High-speed counter 0 (Phase-B, Decrement, or Direction input)		

- Note**
- General-purpose inputs 8 and 9 cannot be used when high-speed counter input 0 is being used. Also, general-purpose input 3, interrupt input 3, and quick-response input 3 cannot be used when high-speed counter 0 is being reset by the phase-Z signal.
General-purpose inputs 6 and 7 cannot be used when high-speed counter input 1 is being used. Also, general-purpose input 2, interrupt input 2, and quick-response input 2 cannot be used when high-speed counter 1 is being reset by the phase-Z signal.
 - Inputs IN0, IN1, and IN4 are used for the origin search function when the origin search function for pulse output 0 is enabled in the PLC Setup. In-

puts IN2, IN3, and IN5 are used for the origin search function when the origin search function for pulse output 1 is enabled in the PLC Setup.

- General-purpose inputs 0 and 1, interrupt inputs 0 and 1, and quick-response inputs 0 and 1 cannot be used when the origin search function for pulse output 0 is being used. Also, general-purpose input 4 cannot be used if operating mode 2 is specified, i.e., the Positioning Completed Signal is being used.
- General-purpose inputs 2 and 3, interrupt inputs 2 and 3, and quick-response inputs 2 and 3 cannot be used when the origin search function for pulse output 1 is being used. Also, general-purpose input 5 cannot be used if operating mode 2 is specified, i.e., the Positioning Completed Signal is being used.

Functions

Item		Specifications	
1) General-purpose inputs (10 inputs max.)		The CPU Unit's built-in inputs (bits 00 to 09 of CIO 2960) can be used as general-purpose inputs.	<p>Note 1: The inputs can be refreshed immediately with the immediate refreshing variation (! prefix) of instructions such as LD.</p> <p>Note 2: The same input time constant is used for all 10 inputs and set in the PLC Setup. The setting range is 0 to 32 ms and the default setting is 8 ms.</p>
2) Interrupt inputs (4 inputs max.)	Direct mode	<p>Interrupt tasks 140 to 143 can be controlled by the CPU Unit's built-in inputs (bits 00 to 03 of CIO 2960) and the interrupt tasks can be set to start on the rising or falling edge of the control bits, i.e., up or down differentiation.</p> <p>The response time (between the establishment of the input condition and execution of the interrupt task) is approximately 0.2 ms.</p>	<p>Note Use the MSKS(690) instruction to specify Direct or Counter mode operation as well as up or down differentiation.</p>
	Counter mode	The rising or falling edge of the inputs (bits 00 to 03 of CIO 2960) can be counted as an incrementing or decrementing counter with a maximum response frequency of 1 kHz. The corresponding interrupt task (140 to 143) can be executed when the counter counts out.	
3) Quick-response inputs (4 inputs max.)		The CPU Unit's built-in inputs (bits 00 to 03 of CIO 2960) can be used as quick-response inputs. Inputs with an input signal width as short as 30 μs can be received reliably regardless of the cycle time and the input signal will be kept on for 1 cycle.	

Item		Specifications	
4) High-speed counter inputs (2 inputs max.)	Gate (stop count) function	<p>The CPU Unit's built-in inputs can be used as high-speed counters. (High-speed counter 0 uses bits 03, 08, 09 of CIO 2960 and high-speed counter 1 uses bits 02, 06, 07 of CIO 2960.)</p> <ul style="list-style-type: none"> Differential phase input (4x multiplication) 30 kHz (50 kHz) Pulse + direction input 60 kHz (100 kHz) Up/down pulse input 60 kHz (100 kHz) Increment input 60 kHz (100 kHz) <p>Note 1: The first figures are the max. frequencies for 24-V DC inputs and the figures in parentheses are for line driver inputs.</p> <p>Note 2: The phase-Z input for high-speed counters 0 and 1 cannot be used if the origin search function for pulse output 1 is being used.</p>	The status of the high-speed counter PV can be controlled (maintained or refreshed) with the High-speed Counter Gate Bits (A53108 and A53109).
	Target value comparison interrupt		An interrupt task (any task from 0 to 255) can be started when the high-speed counter's PV matches the set value specified by the CTBL(882) instruction.
	Range comparison interrupt		An interrupt task (any task from 0 to 255) can be started when the high-speed counter's PV is within the range specified by the CTBL(882) instruction.
	Frequency (speed) measurement function		<p>The high-speed counter's frequency (speed) can be measured by executing the PRV(881) instruction. (High-speed counter 0 only)</p> <ul style="list-style-type: none"> Measurement range with Differential phase input mode: 0 to 50 kHz Measurement range with all other input modes: 0 to 100 kHz
	Frequency conversion		PRV2(883) read the pulse frequency and converts it to a rotational speed (r/min) or it converts the counter PV to a total number of rotations. Results are calculated by the number of pulses/rotation. (High-speed counter 0 only)

2-2 Allocations for Built-in CPU Unit Outputs

Select 1) General-purpose outputs, 2) Fixed duty ratio pulse outputs, or 3) Variable duty ratio pulse outputs by executing the appropriate instruction, as shown in the following table.

Instruction/PLC Setup			Settings other than those to the right	Function set by execution of a pulse output instruction (SPED(885), ACC(888), or PLS2(887))		Origin search function enabled with the PLC Setup	Function set by execution of PWM(891) instruction
Address	Code		1) General-purpose outputs	2) Fixed duty ratio pulse outputs			3) Variable duty ratio pulse outputs
				CW and CCW	Pulse + Direction	Origin search used in operation	
CIO 2961	Bit 00	OUT0	General-purpose output 0	Pulse output 0 (CW)	Pulse output 0 (Pulse)	---	---
	Bit 01	OUT1	General-purpose output 1	Pulse output 0 (CCW)	Pulse output 1 (Pulse)	---	---
	Bit 02	OUT2	General-purpose output 2	Pulse output 1 (CW)	Pulse output 0 (Direction)	---	---
	Bit 03	OUT3	General-purpose output 3	Pulse output 1 (CCW)	Pulse output 1 (Direction)	---	---
	Bit 04	OUT4	General-purpose output 4	---	---	Origin search 0 (Error Counter Reset Output)	PWM(891) output 0
	Bit 05	OUT5	General-purpose output 5	---	---	Origin search 1 (Error Counter Reset Output)	PWM(891) output 1 (See note 3.)
CIO 2960 (for reference)	Bit 00	IN0				Origin search 0 (Origin Input Signal)	
	Bit 01	IN1				Origin search 0 (Origin Proximity Input Signal)	
	Bit 02	IN2				Origin search 1 (Origin Input Signal)	
	Bit 03	IN3				Origin search 1 (Origin Proximity Input Signal)	
	Bit 04	IN4				Origin search 0 (Positioning Completed Signal)	
	Bit 05	IN5				Origin search 1 (Positioning Completed Signal)	

- Note**
1. General-purpose outputs 4 and 5 and PWM(891) outputs 0 and 1 cannot be used when the PLC Setup has been set to enable the origin search function for pulse outputs 0 and 1.
 2. When the PLC Setup has been set to enable the origin search function, outputs OUT4 and OUT5 are used as the Error Counter Reset Outputs and inputs IN0 to IN5 are used as the Origin Inputs, Origin Proximity Inputs, and Positioning Completed Signals. (Depending on the operating mode, some of these I/O points may not be usable.)
 3. PWM(891) output 1 can be used only with the CJ1M-CPU22/CPU23.

Functions

Item		Specifications	
1) General-purpose outputs (6 outputs)		The CPU Unit's built-in outputs (bits 00 to 05 of CIO 2961) can be used as general-purpose outputs.	Note The outputs can be refreshed immediately with the immediate refreshing variation (! prefix) of instructions such as OUT.
2) Fixed duty ratio pulse outputs (2 outputs)	<ul style="list-style-type: none"> Pulse output without acceleration/deceleration (using SPED(885) instruction) Pulse output with trapezoidal acceleration/deceleration; same rate for acceleration/deceleration (using ACC(888) instruction) Pulse output with acceleration/deceleration; different rates for acceleration/deceleration and non-zero starting frequency (using PLS2(887) instruction) 	The CPU Unit's built-in outputs (bits 00 to 03 of CIO 2961) can be used as pulse outputs 0 and 1. Target frequency: 0 Hz to 100 kHz Duty ratio: 50% The pulse output method can be set to CW/CCW outputs or pulse + direction outputs in the instruction operands.	Note 1: The PV for pulse output 0 is stored in A276 and A277. The PV for pulse output 1 is stored in A278 and A279. Note 2: The PLS2(887) instruction can be executed during positioning to change the target position. (Multiple start) Note 3: The PLS2(887) instruction can be executed during speed control to perform positioning to change the target position. (Fixed distance feed interrupt)
3) Variable duty ratio pulse outputs (CJ1M-CPU22/23: 2 outputs, CJ1M-CPU21: 1 output)		The PWM(891) instruction can be executed to use the CPU Unit's built-in outputs (bits 04 and 05 of CIO 2961) as PWM(891) outputs 0 and 1.	

2-3 Allocations for Origin Search Function

To use the origin search function, enable the origin search function for the pulse output in the PLC Setup.

The origin search function uses several of the CPU Unit's built-in I/O points in addition to the pulse outputs, as described below, so these I/O points cannot be used for other purposes when the origin search function is being used.

- When the origin search function is being used for pulse outputs 0 and 1, outputs OUT4 and OUT5 are used for the Error Counter Reset Output and inputs IN0 through IN5 are used for the Origin Input Signals, Origin Proximity Input Signals, and Positioning Completed Signals. These I/O points cannot be used for other purposes if the origin search function is being used, except for the Error Counter Reset Outputs and Positioning Completed Signals, which are not used in some origin search operating modes.

The origin return function moves the system to the origin location predetermined by the origin search function or preset pulse output PV.

The origin return function can be used only for the pulse outputs.

■ Inputs

Code		IN0	IN1	IN2	IN3	IN4	IN5	IN6	IN7	IN8	IN9
Address	Word	CIO 2960									
	Bit	00	01	02	03	04	05	06	07	08	09
Inputs	General-purpose inputs	General-purpose input 0	General-purpose input 1	General-purpose input 2	General-purpose input 3	General-purpose input 4	General-purpose input 5	General-purpose input 6	General-purpose input 7	General-purpose input 8	General-purpose input 9
	Interrupt inputs	Interrupt input 0	Interrupt input 1	Interrupt input 2	Interrupt input 3	---	---	---	---	---	---
	Quick-response inputs	Quick-response input 0	Quick-response input 1	Quick-response input 2	Quick-response input 3	---	---	---	---	---	---
	High-speed counters	---	---	High-speed counter 1 (phase-Z/reset)	High-speed counter 0 (phase-Z/reset)	---	---	High-speed counter 1 (phase-A, increment, or count input)	High-speed counter 1 (phase-B, decrement, or direction input)	High-speed counter 0 (phase-A, increment, or count input)	High-speed counter 0 (phase-B, decrement, or direction input)

■ Outputs

Code		OUT0	OUT1	OUT2	OUT3	OUT4	OUT5	
Address	Word	CIO 2961						
	Bit	00	01	02	03	04	05	
Outputs	General-purpose outputs	General-purpose output 0	General-purpose output 1	General-purpose output 2	General-purpose output 3	General-purpose output 4	General-purpose output 5	
	Pulse outputs	CW/CCW	Pulse output 0 (CW)	Pulse output 0 (CCW)	Pulse output 1 (CW)	Pulse output 1 (CCW)	---	---
		Pulse + direction	Pulse output 0 (pulse)	Pulse output 1 (pulse)	Pulse output 0 (direction)	Pulse output 1 (direction)	---	---
		Pulse output with variable duty	---	---	---	---	PWM(891) output 0	PWM(891) output 1 (See note.)

Note PWM(891) output 1 cannot be used on the CJ1M-CPU21.

■ Origin Search

Code	IN0	IN1	IN2	IN3	IN4	IN5	IN6 to IN9	OUT0 to OUT3	OUT4	OUT5	
Address	Word	CIO 2960						CIO 2961			
	Bit	00	01	02	03	04	05	06 to 09	00 to 03	04	05
Origin search	Origin search 0 (Origin Input Signal)	Origin search 0 (Origin Proximity Input Signal)	Origin search 1 (Origin Input Signal)	Origin search 1 (Origin Proximity Input Signal)	Origin search 0 (Positioning Completed Signal)	Origin search 1 (Positioning Completed Signal)	---	---	Origin search 0 (Error Counter Reset Output)	Origin search 1 (Error Counter Reset Output)	

Functions

Item	Specifications
Origin search	<p>If the ORG(889) (ORIGIN SEARCH) instruction is executed and the origin search function is enabled in the PLC Setup, the origin search operation will start and the origin location will be determined based on the Origin Proximity Input Signal and Origin Input Signal. At this point, the coordinates for the pulse output PV will automatically be set to absolute coordinates.</p> <p>Note Outputs OUT4/OUT5 are used for the Error Counter Reset Outputs. Inputs IN0 through IN5 are used for the Origin Input Signals, Origin Proximity Input Signals, and Positioning Completed Signals. (The Error Counter Reset Output and Positioning Completed Signal are not used in all origin search operating modes.)</p>
Origin return	<p>If the ORG(889) (ORIGIN SEARCH) instruction is executed and the origin search function is enabled in the PLC Setup, the origin return operation will move the system to the pre-determined origin location.</p>

SECTION 3

I/O Specifications and Wiring

This section provides I/O specifications and wiring instructions for the built-in I/O.

3-1	I/O Specifications	20
3-1-1	Input Specifications	20
3-1-2	Output Specification	22
3-2	Wiring	23
3-2-1	Connector Pin Allocations	23
3-2-2	Connector Pins Used by Each Function	24
3-2-3	Wiring Methods	28
3-3	Wiring Examples	32
3-3-1	General-purpose I/O Connection Examples	32
3-3-2	Pulse Input Connection Examples	35
3-3-3	Power Supply Input Connection Example	36
3-3-4	Pulse Output Connection Examples	37
3-3-5	Error Counter Reset Output Connection Examples	40
3-3-6	Motor Driver Connection Examples	40
3-3-7	Variable Duty Ratio Pulse Output (PWM(891) Output) Connection Example	49

3-1 I/O Specifications

3-1-1 Input Specifications

General-purpose Input Specifications

Inputs	IN0 to IN5	IN6 to IN9	IN0 to IN5	IN6 to IN9
Input type	Two-wire Sensor		Line driver inputs	
Input current	6.0 mA typical	5.5 mA typical	13 mA typical	10 mA typical
Input voltage	24 V DC +10%, -15%		RS-422A line driver AM26LS31 standards (See note 1.)	
Input impedance	3.6 kΩ	4.0 kΩ	---	
Number of circuits	1 common, 1 circuit			
ON voltage/current	17.4 V DC min., 3 mA min.		---	
OFF voltage/current	5 V DC max., 1 mA max.		---	
ON delay	8 ms max. (See note 2.)			
OFF delay	8 ms max. (See note 2.)			

- Note**
1. The power supply voltage on the line driver side is 5 V ±5%.
 2. The input time constant can be set to 0, 0.5, 1, 2, 4, 8, 16, or 32 μs. When it is set to 0 ms, the delay due to internal components results in an ON delay of 30 μs max. for IN0 to IN5 (2 μs max. for IN6 to IN9) and an OFF delay of 150 μs max. for IN0 to IN5 (2 μs max. for IN6 to IN9).

Circuit Configuration

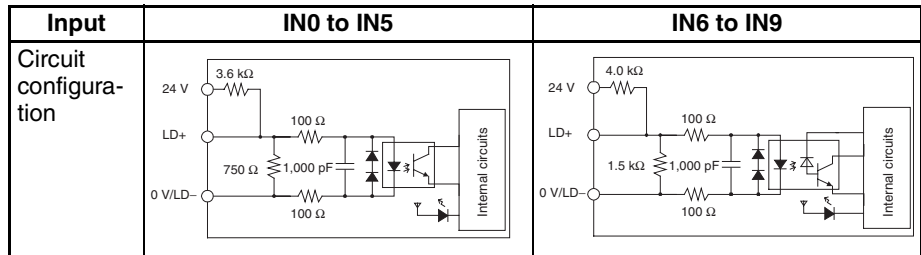

Interrupt Input and Quick-response Input Specifications (IN0 to IN3)

Item	Specifications
ON delay	30 μs max.
OFF delay	150 μs max.
Response pulse	

High-speed Counter Input Specifications (IN6 to IN9)

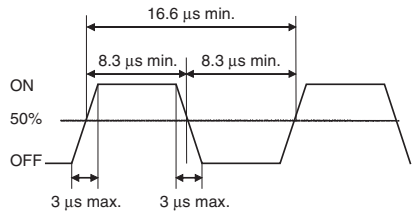
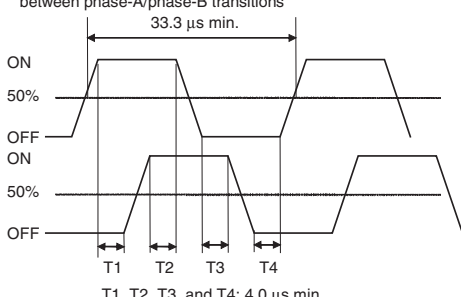
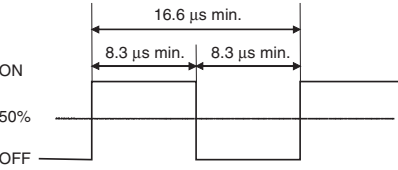
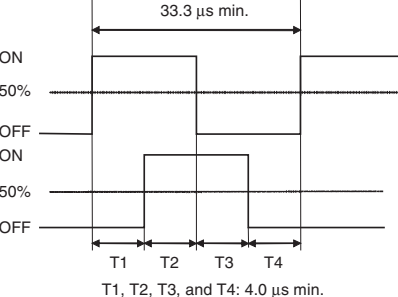
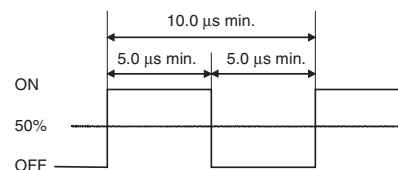
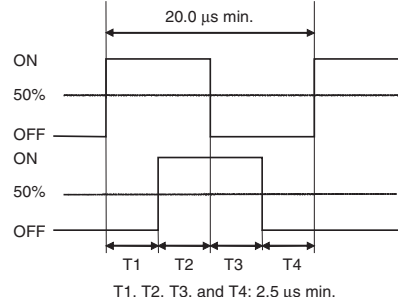
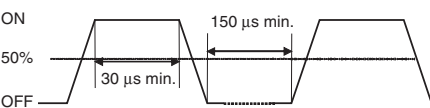
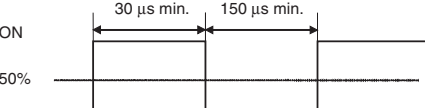
Input	24-V DC inputs	Line driver inputs
<p>Set to 60 kHz</p>	<p>Phase-A/Phase-B encoder input, Single-phase 60-kHz pulse input with 50% duty ratio Rise time and fall time: 3.0 μs max.</p>  <p>Phase-A/Phase-B encoder input, Differential-phase 30-kHz pulse input Maintain a spacing of 4.0 μs min. between phase-A/phase-B transitions</p> 	<p>Phase-A/Phase-B encoder input, Single-phase 60-kHz pulse input with 50% duty ratio</p>  <p>Phase-A/Phase-B encoder input, Differential-phase 30-kHz pulse input Maintain a spacing of 4.0 μs min. between phase-A/phase-B transitions</p> 
<p>Set to 100 kHz</p>	<p>Counting operations are unreliable at frequencies higher than 60 kHz.</p>	<p>Single-phase 100-kHz pulse input with 50% duty ratio</p>  <p>Differential-phase 50-kHz pulse input Maintain a spacing of 2.5 μs min. between Phase A/Phase B transitions</p> 
<p>Phase-Z/Reset input</p>	<p>Phase-Z encoder input (IN2 and IN3) Maintain an ON time of 30 μs min. and an OFF time of 150 μs min.</p> 	<p>Phase-Z encoder input (IN2 and IN3) Maintain an ON time of 30 μs min. and an OFF time of 150 μs min.</p> 

Note In order for the counter inputs to satisfy the specifications shown in the table above, it will be necessary to check the factors that can affect the pulses, such as the type of output driver in the encoder, encoder cable length, and count pulse frequency. In particular, the rise time and fall time may be too long and the input waveform may not be within specifications when a long encoder cable is used to connect an encoder that has 24-V open collector inputs. When a long cable is connected, either shorten the encoder cable or use an encoder with line driver outputs.

3-1-2 Output Specification

Transistor Outputs (Sinking)

General-purpose Output Specifications

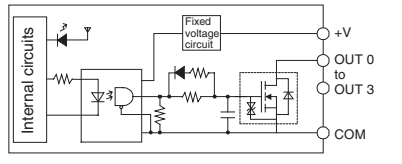
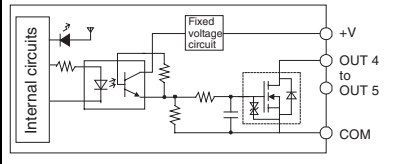
Output	OUT0 to OUT3	OUT4 to OUT5
Rated voltage	5 to 24 V DC	
Allowable voltage range	4.75 to 26.4 V DC	
Max. switching capacity	0.3 A/output; 1.8 A/Unit	
Number of circuits	6 outputs (6 outputs/common)	
Max. inrush current	3.0 A/output, 10 ms max.	
Leakage current	0.1 mA max.	
Residual voltage	0.6 V max.	
ON delay	0.1 ms max.	
OFF delay	0.1 ms max.	
Fuse	None	
External power supply	10.2 to 26.4 V DC 50 mA min.	
Circuit configuration		

Pulse Output Specifications (OUT0 to OUT3)

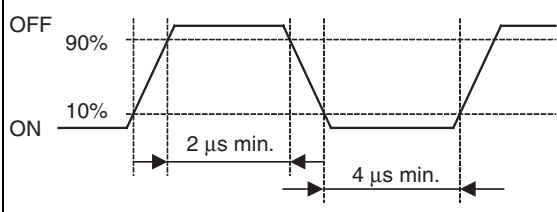
Item	Specifications
Max. switching capacity	30 mA, 4.75 to 26.4 V DC
Min. switching capacity	7 mA, 4.75 to 26.4 V DC
Max. output frequency	100 kHz
Output waveform	

- Note**
1. The values shown above are for a resistive load and do not consider the impedance of the cable connecting the load.
 2. The pulse waveform may be distorted by the connecting cable's impedance, and thus the actual pulse width may be shorter than the values shown above.

PWM(891) Output Specifications (OUT4 and OUT5)

Item	Specifications
Max. switching capacity	300 mA, 4.75 to 26.4 V DC
Max. output frequency	1 kHz
PWM(891) output accuracy	ON duty: +5%/-0% for a 1-kHz pulse output
Output waveform	

Note The CJ1W-CPU21 supports only OUT4. OUT5 cannot be used.

3-2 Wiring

3-2-1 Connector Pin Allocations

Pin layout	Code	Name	Input signal type	Pin No.	*1	Code	Name	Input signal type	Pin No.	*1	
	IN0	<ul style="list-style-type: none"> General-purpose input 0 Interrupt input 0 Quick-response input 0 Origin search 0 (Origin Input Signal) 	24 V DC	1	A1	IN1	<ul style="list-style-type: none"> General-purpose input 0 Interrupt input 0 Quick-response input 0 Origin search 0 (Origin Proximity Input Signal) 	24 V DC	2	B1	
			LD+	3	A2			4	B2		
			0 V/LD-	5	A3			6	B3		
	IN2	<ul style="list-style-type: none"> General-purpose input 2 Interrupt input 2 Quick-response input 2 High-speed counter 1 (Phase-Z/Reset input) Origin search 1 (Origin Input Signal) 	24 V DC	7	A4	IN3	<ul style="list-style-type: none"> General-purpose input 3 Interrupt input 3 Quick-response input 3 High-speed counter 0 (Phase-Z/Reset input) Origin search 1 (Origin Proximity Input Signal) 	24 V DC	8	B4	
			LD+	9	A5			10	B5		
			0 V/LD-	11	A6			12	B6		
	IN4	<ul style="list-style-type: none"> General-purpose input 4 Origin search 0 (Positioning Completed Signal) 	24 V DC	13	A7	IN5	<ul style="list-style-type: none"> General-purpose input 5 Origin search 1 (Positioning Completed Signal) 	24 V DC	14	B7	
			LD+	15	A8			16	B8		
			0 V/LD-	17	A9			18	B9		
	IN6	<ul style="list-style-type: none"> General-purpose input 6 High-speed counter 1 (Phase-A, Increment, or Count input) 	24 V DC	19	A10	IN7	<ul style="list-style-type: none"> General-purpose input 7 High-speed counter 1 (Phase-B, Decrement, or Direction input) 	24 V DC	20	B10	
			LD+	21	A11			22	B11		
			0 V/LD-	23	A12			24	B12		
	IN8	<ul style="list-style-type: none"> General-purpose input 8 High-speed counter 0 (Phase-A, Increment, or Count input) 	24 V DC	25	A13	IN9	<ul style="list-style-type: none"> General-purpose input 9 High-speed counter 0 (Phase-B, Decrement, or Direction input) 	24 V DC	26	B13	
			LD+	27	A14			28	B14		
			0 V/LD-	29	A15			30	B15		
OUT0	General-purpose output 0	<ul style="list-style-type: none"> In CW/CCW mode: Pulse output 0 (CW) In Pulse + Direction mode: Pulse output 0 (pulse) 	---	31	A16	OUT1	General-purpose output 1	---	32	B16	
OUT2	<ul style="list-style-type: none"> In CW/CCW mode: Pulse output 1 (CW) In Pulse + Direction mode: Pulse output 0 (direction) 		---	33	A17	OUT3	<ul style="list-style-type: none"> In CW/CCW mode: Pulse output 1 (CCW) In Pulse + Direction mode: Pulse output 1 (direction) 		---	34	B17
---	Power supply input (+V) for the output	---	---	37	A19	---	Not used	---	38	B19	
---	Output COM	---	---	39	A20	---	Output COM	---	40	B20	

*1: These are the pins on the XW2D-□□G□ Terminal Block.

*2: PWM(891) output 1 can be used only with the CJ1M-CPU22/CPU23.

3-2-2 Connector Pins Used by Each Function

Built-in Inputs

General-purpose Inputs

Input number	Code	Pin No.	Content
General-purpose input 0	IN0	1	24 V DC
		5	0 V
General-purpose input 1	IN1	2	24 V DC
		6	0 V
General-purpose input 2	IN2	7	24 V DC
		11	0 V
General-purpose input 3	IN3	8	24 V DC
		12	0 V
General-purpose input 4	IN4	13	24 V DC
		17	0 V
General-purpose input 5	IN5	14	24 V DC
		18	0 V
General-purpose input 6	IN6	19	24 V DC
		23	0 V
General-purpose input 7	IN7	20	24 V DC
		24	0 V
General-purpose input 8	IN8	25	24 V DC
		29	0 V
General-purpose input 9	IN9	26	24 V DC
		30	0 V

Interrupt Inputs

Input number	Code	Pin No.	Content
Interrupt input 0	IN0	1	24 V DC
		5	0 V
Interrupt input 1	IN1	2	24 V DC
		6	0 V
Interrupt input 2	IN2	7	24 V DC
		11	0 V
Interrupt input 3	IN3	8	24 V DC
		12	0 V

Quick-response Inputs

Input number	Code	Pin No.	Content
Quick-response input 0	IN0	1	24 V DC
		5	0 V
Quick-response input 1	IN1	2	24 V DC
		6	0 V
Quick-response input 2	IN2	7	24 V DC
		11	0 V
Quick-response input 3	IN3	8	24 V DC
		12	0 V

High-speed Counters

High-speed Counters Using Differential-phase Inputs**Encoder with phases A, B, and Z**

Input number	Code	Pin No.	Content
High-speed counter 0	IN8	25	Phase A, 24 V
		29	Phase A, 0 V
	IN9	26	Phase B, 24 V
		30	Phase B, 0 V
	IN3	8	Phase Z, 24 V
		12	Phase Z, 0 V
High-speed counter 1	IN6	19	Phase A, 24 V
		23	Phase A, 0 V
	IN7	20	Phase B, 24 V
		24	Phase B, 0 V
	IN2	7	Phase Z, 24 V
		11	Phase Z, 0 V

Encoder with Line Driver Outputs

Input number	Code	Pin No.	Content
High-speed counter 0	IN8	27	Phase A, LD+
		29	Phase A, LD-
	IN9	28	Phase B, LD+
		30	Phase B, LD-
	IN3	10	Phase Z, LD+
		12	Phase Z, LD-
High-speed counter 1	IN6	21	Phase A, LD+
		23	Phase A, LD-
	IN7	22	Phase B, LD+
		24	Phase B, LD-
	IN2	9	Phase Z, LD+
		11	Phase Z, LD-

High-speed Counters Using Pulse + Direction Inputs

Input number	Code	Pin No.	Content
High-speed counter 0	IN8	25	Count input, 24 V
		29	Count input, 0 V
	IN9	26	Direction input, 24 V
		30	Direction input, 0 V
	IN3	8	Reset input, 24 V
		12	Reset input, 0 V
High-speed counter 1	IN6	19	Count input, 24 V
		23	Count input, 0 V
	IN7	20	Direction input, 24 V
		24	Direction input, 0 V
	IN2	7	Reset input, 24 V
		11	Reset input, 0 V

High-speed Counters Using Up/Down Pulse Inputs

Input number	Code	Pin No.	Content
High-speed counter 0	IN8	25	Increment input, 24 V
		29	Increment input, 0 V
	IN9	26	Decrement input, 24 V
		30	Decrement input, 0 V
	IN3	8	Reset input, 24 V
		12	Reset input, 0 V
High-speed counter 1	IN6	19	Increment input, 24 V
		23	Increment input, 0 V
	IN7	20	Decrement input, 24 V
		24	Decrement input, 0 V
	IN2	7	Reset input, 24 V
		11	Reset input, 0 V

High-speed Counters Using Increment Pulse Inputs

Input number	Code	Pin No.	Content
High-speed counter 0	IN8	25	Count input, 24 V
		29	Count input, 0 V
	IN3	8	Reset input, 24 V
		12	Reset input, 0 V
High-speed counter 1	IN6	19	Count input, 24 V
		23	Count input, 0 V
	IN2	7	Reset input, 24 V
		11	Reset input, 0 V

Built-in Outputs

General-purpose Outputs

Output number	Code	Pin No.	Content
General-purpose output 0	OUT0	31	Output 0
		37	Power supply input (+V) for the output
		39 or 40	Output COM
General-purpose output 1	OUT1	32	Output 1
		37	Power supply input (+V) for the output
		39 or 40	Output COM
General-purpose output 2	OUT2	33	Output 2
		37	Power supply input (+V) for the output
		39 or 40	Output COM
General-purpose output 3	OUT3	34	Output 3
		37	Power supply input (+V) for the output
		39 or 40	Output COM
General-purpose output 4	OUT4	35	Output 4
		37	Power supply input (+V) for the output
		39 or 40	Output COM

Output number	Code	Pin No.	Content
General-purpose output 5	OUT5	36	Output 5
		37	Power supply input (+V) for the output
		39 or 40	Output COM

Pulse Outputs

Pulse Outputs Using CW/CCW Outputs

Output number	Code	Pin No.	Content
Pulse output 0	OUT0	31	CW pulse output
		32	CCW pulse output
		37	Power supply input (+V) for the output
		39 or 40	Output COM
Pulse output 1	OUT1	33	CW pulse output
		34	CCW pulse output
		37	Power supply input (+V) for the output
		39 or 40	Output COM

Pulse Outputs Using Pulse + Direction Outputs

Output number	Code	Pin No.	Content
Pulse output 0	OUT0	31	Pulse output
		33	Direction output
		37	Power supply input (+V) for the output
		39 or 40	Output COM
Pulse output 1	OUT1	32	Pulse output
		34	Direction output
		37	Power supply input (+V) for the output
		39 or 40	Output COM

PWM(891) Outputs

Output number	Code	Pin No.	Content
PWM(891) output 0	OUT4	35	PWM(891) output
		39 or 40	Output COM
PWM(891) output 1 (See note.)	OUT5	36	PWM(891) output
		39 or 40	Output COM

Note PWM(891) output 1 can be used only with the CJ1M-CPU22/CPU23.

I/O Used in the Origin Search Function

Output number	Code	Pin No.	Content
Origin search 0	IN0	1	Origin Input Signal, 24 V DC
		5	0 V
	IN1	2	Origin Proximity Input Signal, 24 V DC
		6	0 V
	IN4	13	Positioning Completed Signal, 24 V DC
		17	0 V
	OUT4	35	Error Counter Reset Output
		37	Power supply input (+V) for the output
		39 or 40	Output COM
Origin search 1	IN2	7	Origin Input Signal, 24 V DC
		11	0 V
	IN3	8	Origin Proximity Input Signal, 24 V DC
		12	0 V
	IN5	14	Positioning Completed Signal, 24 V DC
		18	0 V
	OUT5	36	Error Counter Reset Output
		37	Power supply input (+V) for the output
		39 or 40	Output COM

3-2-3 Wiring Methods

To connect to a Terminal Block, use an OMRON Cable preassembled with the special connector or attach the special connector (sold separately) to a cable yourself.

- Note**
- Do not supply a voltage to the input terminals that exceeds the I/O circuit's specified input voltage range. Likewise, do not connect a voltage or load that exceeds the output circuit's max. switching capacity.
 - When the power supply terminals are marked with + and – indicators, verify that the power supply wires have not been reversed accidentally.
 - When the equipment is subject to EC Directives (the Low Voltage Directives), a DC power supply with reinforced insulation or double insulation must be used for the I/O power supply.
 - Double-check all connector wiring before turning ON the power supply.
 - Do not pull on the cable. Doing so may separate the cable from the connector.
 - Do not bend the cable too sharply. Doing so may damage the cable.
 - The connector pin allocation of the CJ1W-ID232/262 and OD233/263 connectors is not compatible. The Unit's internal circuits may be damaged if one of these connectors is connected.
 - Do not connect a 24-V DC output device to a line driver input. Doing so may damage the internal circuits.

- Do not connect a line driver output device to a 24-V DC input. Doing so will not damage the internal circuits, but the input will not be recognized.

Connector Models

Compatible Connector Specifications

MIL Flat Cable Connectors (40-pin Pressure-fitted Connectors)

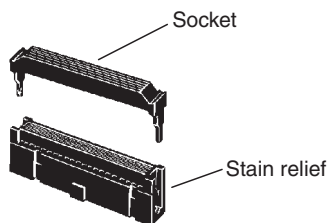

Name	OMRON model number	Daiichi Electronics model number
Socket	XG4M-4030	FRC5-AO40-3TON
Stain Relief	XG4M-4004	---
Set model number	XG4M-4030-T	FRC5-AO40-3TOS
Recommended Flat Cable	XY3A-200□	---

MIL Loose Wire Crimp Connectors (40-pin Pressure-fitted Connectors)

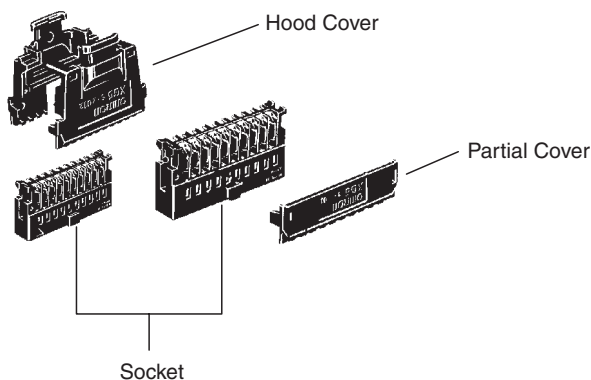

Name	OMRON model number	
Socket	AWG24	XG5M-4032-N
	AWG26 to AWG28	XG5M-4035-N
Spare Contacts (See note 1.)	AWG24	XG5W-0031-N
	AWG26 to AWG28	XG5W-0034-N
Hood Cover (See note 2.)	XG5S-4022	
Partial Cover (See note 2.) (2 required for each socket)	XG5S-2001	

- Note**
- Contacts are included with the Socket.
 - Select either the Hood Cover or the Partial Cover.

Wiring

We recommend using a cable with wires sized between 28 and 24 AWG (0.2 to 0.08 mm²). Use a wire with an outer diameter of 1.61 mm max.

Compatible Terminal Blocks

Recommended Cable	Compatible Terminal Block	Number of pins	Size	Temperature (°C)
XW2Z-□□□K	XW2D-40G6	40	Small	0 to 55
	XW2B-40G5		Standard	-25 to 80
	XW2B-40G4			

Standard Connection Method (Not for OMRON Servo Drivers)

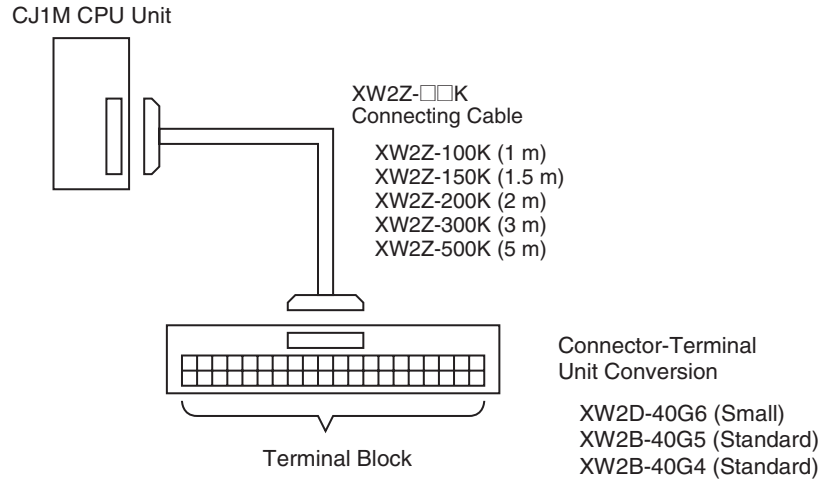

Connecting to an OMRON Servo Driver

The following cable and Relay Unit can be used when connecting an OMRON Servo to the CJ1M CPU Unit's built-in I/O. The configurations shown in the following diagrams will make the necessary Servo Driver connections for the positioning and origin search functions (Origin Input Signal, Origin Proximity Input Signal, Positioning Completed Signal, and Error Counter Reset Output).

One-axis Servo Driver Connection (Connecting Pulse Output 0)

OMRON SMARTSTEP A-series or UE-series Servo Driver

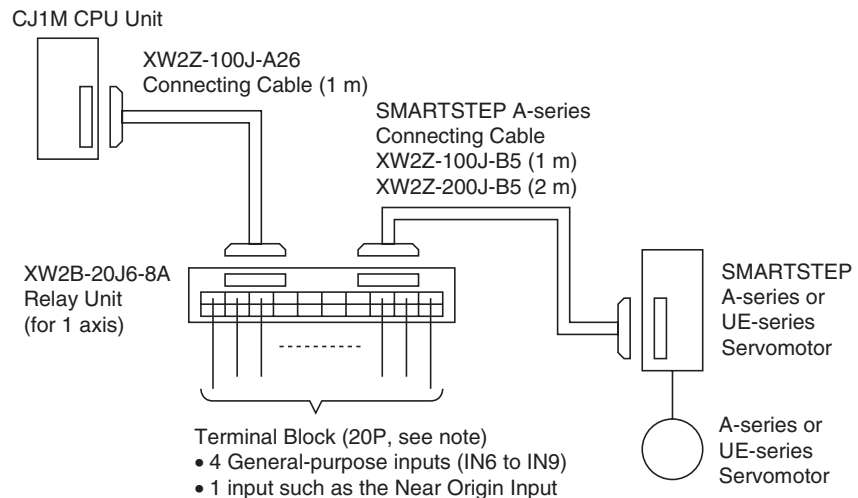

Note When using a One-axis Relay Unit (connected to pulse output 0), general-purpose outputs 2 and 3 (OUT2 and OUT3) and PWM(891) output 1 (OUT5) cannot be used.

OMRON OMNUC W-series, UP-series, or UT-series Servo Driver

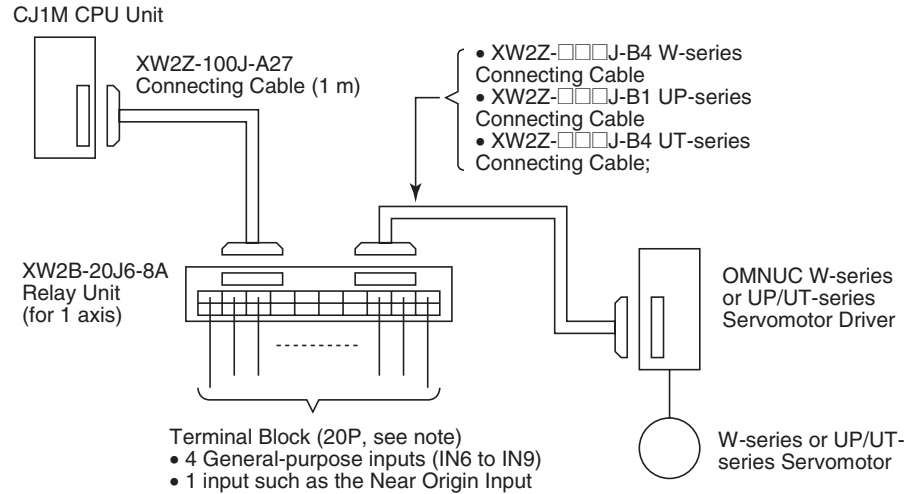

Note When using a One-axis Relay Unit (connected to pulse output 0), general-purpose outputs 2 and 3 (OUT2 and OUT3) and PWM(891) output 1 (OUT5) cannot be used.

Two-axis Servo Driver Connection (Connecting Pulse Outputs 0 and 1)

OMRON SMARTSTEP A-series or UE-series Servo Drivers

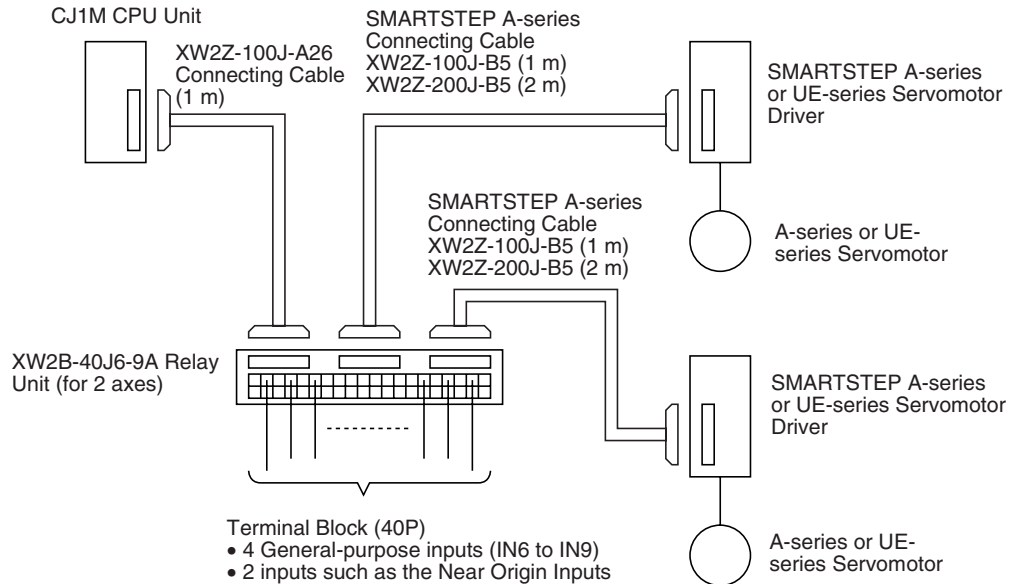

OMRON OMNUC W-series, UP-series, or UT-series Servo Drivers

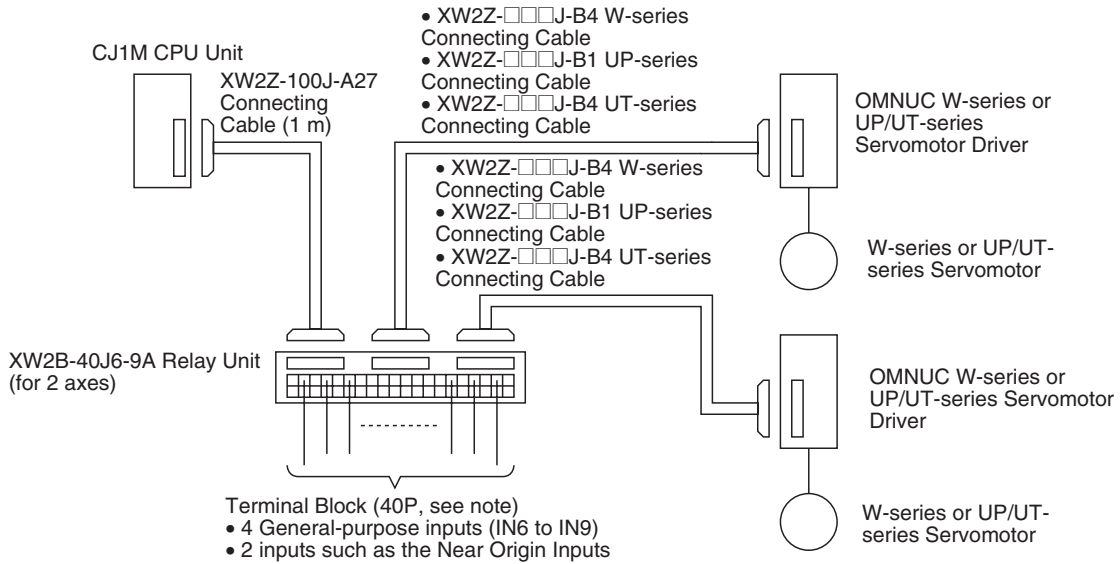

3-3 Wiring Examples

3-3-1 General-purpose I/O Connection Examples

DC Input Devices

• Device with Relay Output

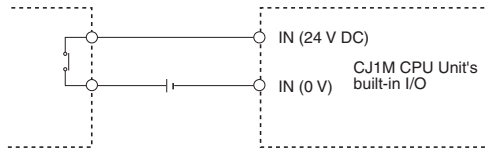

• Two-wire DC Sensor

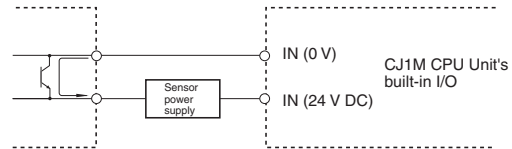

• Device with NPN open collector output

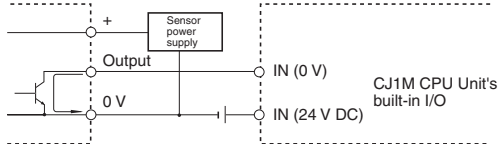

• Device with NPN current output

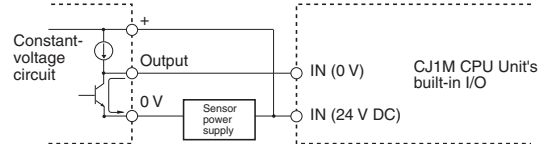

Output; Sensor power supply; IN (0 V); IN (24 V DC); CJ1M CPU Units built-in I/O;

• Device with PNP current output

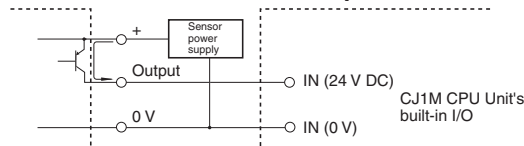

• Device with voltage output (See note.)

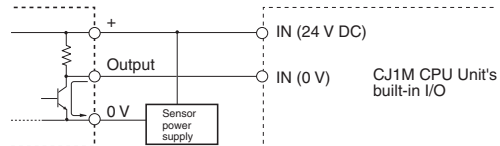

Note Do not use the following wiring with voltage-output devices.

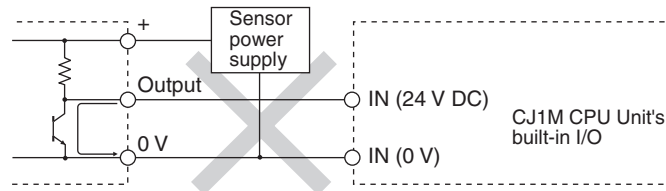

Note The CJ1M CPU Unit's inputs have a set polarity, so the inputs will not go ON if the wiring is reversed. Always double-check the wiring before turning ON the power.

Precautions when Connecting Two-wire DC Sensors

Check that the following conditions are met when using a two-wire sensor as a 24-V DC input device. The sensor may malfunction if the conditions are not met.

- 1,2,3...**
1. Check the relationship between the PLC's ON voltage and the sensor's residual voltage.
 $V_{ON} \leq V_{CC} - V_R$
 2. Check the relationship between the PLC's ON current and the sensor's control output (load current.)
 $I_{OUT} (min.) \leq I_{ON} \leq I_{OUT} (max.)$
 $I_{ON} = (V_{CC} - V_R - 1.5 [PLC's \ internal \ residual \ voltage]*)/R_{IN}$
 Connect a bleeder resistor (R) if I_{ON} is less than $I_{OUT} (min.)$. Use the following equation to determine the proper bleeder resistance.
 $R \leq (V_{CC} - V_R)/(I_{OUT} (min.) - I_{ON})$
 $Power \ W \geq (V_{CC} - V_R)^2/R \times 4 [Tolerance]$
 3. Check the relationship between the PLC's OFF current and the sensor's leakage current.
 $I_{OFF} \geq I_{leak}$
 Connect a bleeder resistor (R) if I_{leak} is greater than I_{OFF} . Use the following equation to determine the proper bleeder resistance.
 $R \leq R_{IN} \times V_{OFF}/(I_{leak} \times R_{IN} - V_{OFF})$
 $Power \ W \geq (V_{CC} - V_R)^2/R \times 4 [Tolerance]$

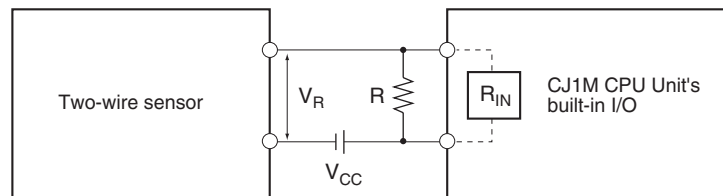

- V_{CC} : Power supply voltage
- V_R : Sensor's residual output voltage
- V_{ON} : PLC's ON voltage
- I_{OUT} : Sensor's control output (load current)
- V_{OFF} : PLC's OFF voltage
- I_{ON} : PLC's ON current
- I_{leak} : Sensor's leakage current
- I_{OFF} : PLC's OFF current
- R: Bleeder resistance
- R_{IN} : PLC's input impedance

4. Precautions Regarding the Sensor Inrush Current
 If the sensor power supply is turned ON when the PLC is already ON and capable of receiving inputs, the sensor's inrush current may cause a false

input. To prevent a false input, it is possible to prepare an application program incorporating a timer delaying inputs from the sensor for a set time after the sensor's power supply is turned ON until the sensor's operation has stabilized.

Example Programming

The sensor's power supply status is read with CIO 000000. The timer provides a delay until the sensor's operation has stabilized (100 ms for an OMRON Proximity Sensor.)

Once TIM 0000 goes ON, output CIO 000100 will be turned ON when a sensor input is received in input bit CIO 000001.

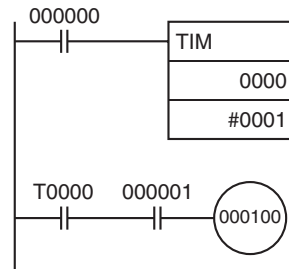

Output Wiring Precautions

Output Short Protection

The output or internal circuitry might be damaged when the load connected to an output is short-circuited, so we recommend installing a protective fuse in each output circuit. Use a fuse with a capacity about two times greater than the rated output capacity.

TTL Connections

A TTL device cannot be connected directly because of the transistor's residual voltage. In this case, connect to a TTL Unit after receiving signals with a CMOS IC. Also, a pull-up resistor must be used with the transistor output.

Inrush Current Considerations

When switching a load with a high inrush current, such as an incandescent light bulb, there is a risk of damaging the output transistor. Suppress the inrush current using one of the methods shown below.

Method 1

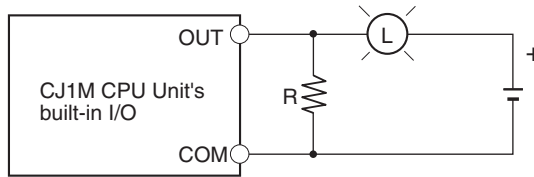

This method draws a dark current that is approximately one-third of the rated value of the light bulb.

Method 2

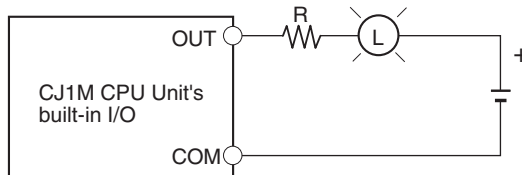

This method uses a limiting resistor.

3-3-2 Pulse Input Connection Examples

Encoders with 24-V DC Open-collector Outputs

This example shows how to connect an encoder that has phase-A, phase-B, and phase-Z outputs.

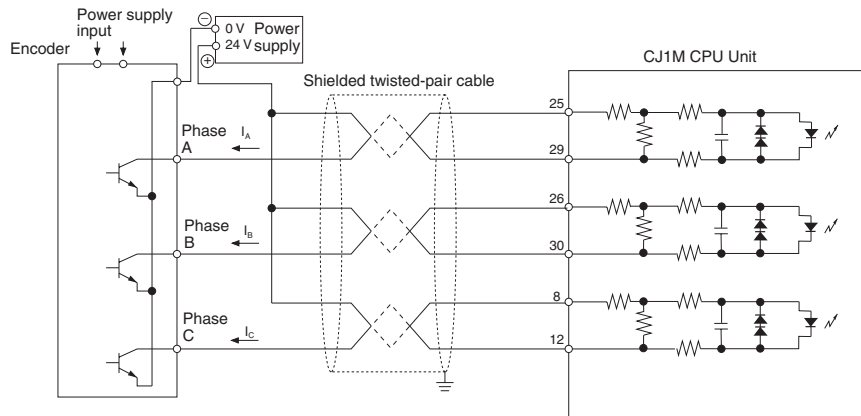
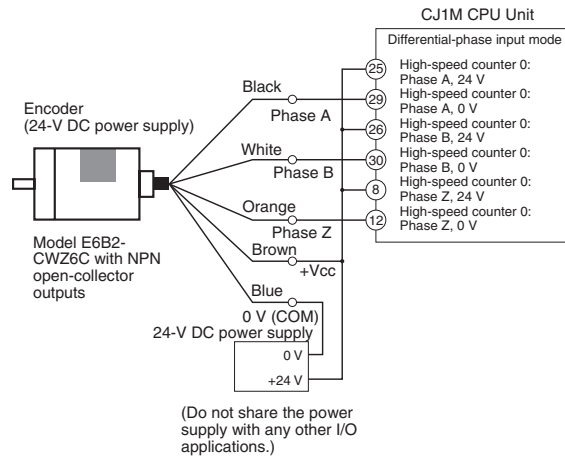

Encoders with Line Driver Outputs (Conforming to Am26LS31)

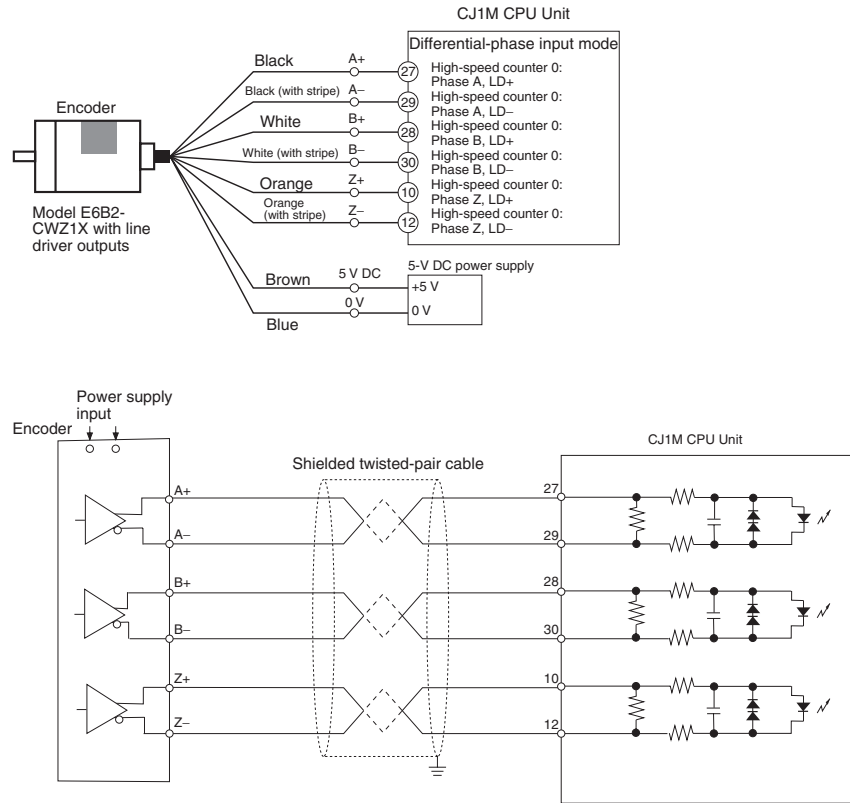

3-3-3 Power Supply Input Connection Example

Make the connections as shown below when using a sensor's open-collector output and an encoder's phase-Z line driver output.

Use a sensor without chattering, such as a Photoelectric Sensor, for the Origin Input Signal.

- Note**
1. Connect a switch or sensor with a switching capacity of 6 mA to the Origin Input Signal (24 V DC) terminal.
 2. Connect only a line driver circuit to the Origin Input Signal (line driver) inputs. Do not connect any kind of output circuit.
 3. Use either the Origin Input Signal (24 V DC) or Origin Input Signal (line driver).

Verify that the Origin Input Signal is connected to the correct terminals. The CPU Unit's internal components may be damaged if both inputs are used simultaneously or the input is connected to the wrong terminal.

Origin Input Signal (24 V DC)

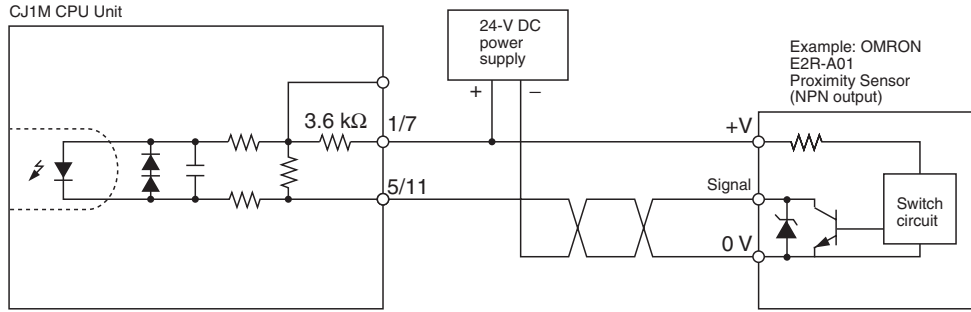

Origin Input Signal (Line Driver Input)

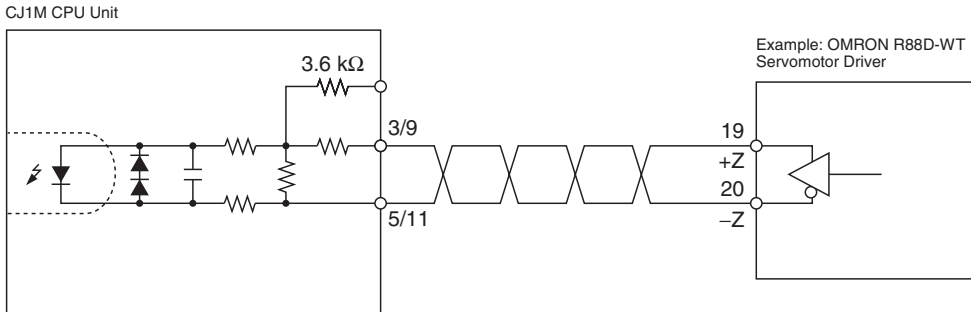

3-3-4 Pulse Output Connection Examples

This section provides examples of connections to motor drivers. Refer to the specifications for the motor driver being used before actually connecting a motor driver. With open-collector outputs, the wire length between the CJ1M CPU Unit and motor driver must not exceed 3 m.

When the pulse output's output transistor is OFF, pulses are not being output.

When the direction output is OFF, it indicates a CCW output.

Do not share the pulse output's power supply (24 V DC or 5 V DC) with any other I/O applications.



CW/CCW Pulse Output

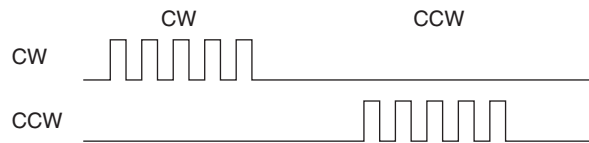

Pulse + Direction Output

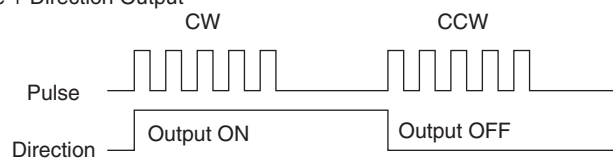

CW/CCW Pulse Output and Pulse plus Direction Output

Using a Motor Driver with 24-V DC Photocoupler Inputs

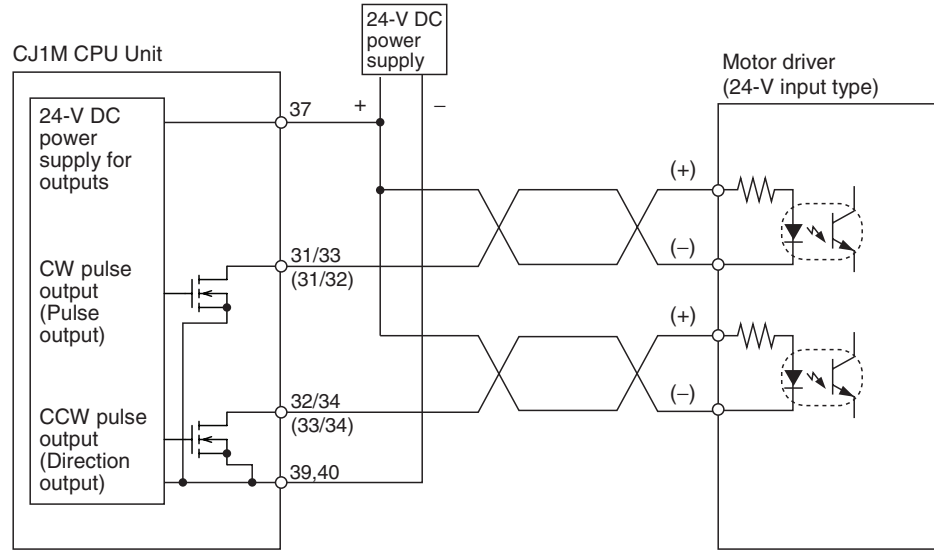

Note The terms in parentheses are for pulse + direction outputs.

Using a Motor Driver with 5-V DC Photocoupler Inputs

Connection Example 1

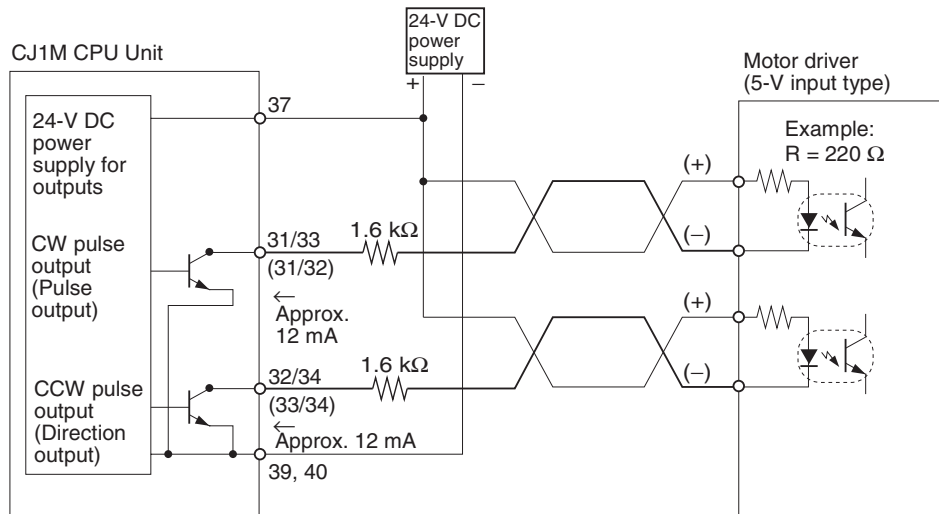

Note The terms in parentheses are for Pulse + Direction outputs.

In this example, the 24-V DC power supply is used for the motor driver with 5-V inputs. Verify that the NC Unit's output current will not damage the motor driver's input circuits. Also verify that the inputs turn ON properly. Check that the 1.6-k Ω resistors have sufficient power derating.

Connection Example 2

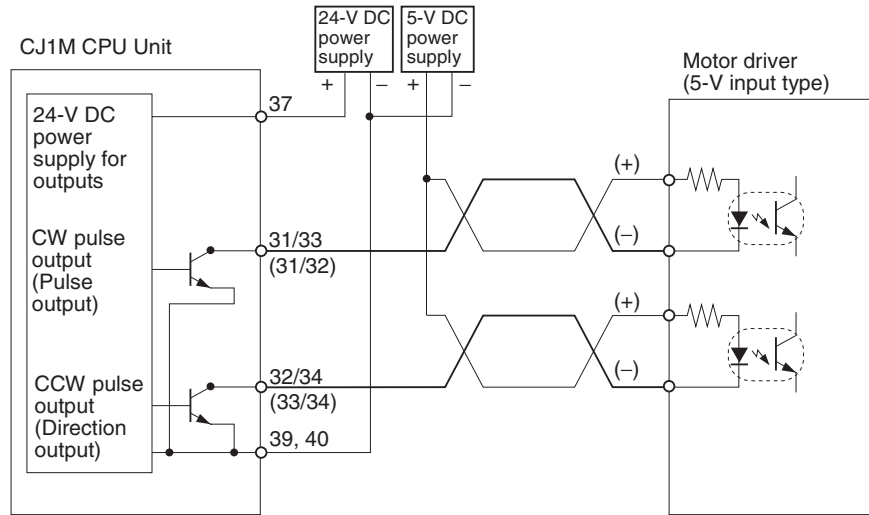

Note The terms in parentheses are for pulse + direction outputs.

Caution When the output is being used as a pulse output, connect a load that requires an output current between 7 and 30 mA. The Unit's internal components may be damaged if the current exceeds 30 mA.

If the current is below 7 mA, the output waveform's rising edge and falling edge will be delayed and the output frequency ratings may not be met. If the load requires less than 7 mA, install a bypass resistor so that the circuit draws a current greater than 7 mA (10 mA is recommended.)

Use the following equations to determine the bypass resistor requirements.

$$R \leq \frac{V_{CC}}{I_{OUT} - I_{IN}}$$

$$\text{Power } W \geq \frac{V_{CC}^2}{R} \times 4 \text{ (Tolerance)}$$

V_{CC} : Output voltage (V)
 I_{OUT} : Output current (A) (7 to 30 mA)
 I_{IN} : Driver input current
 R : Bypass resistance (Ω)

Circuit Example

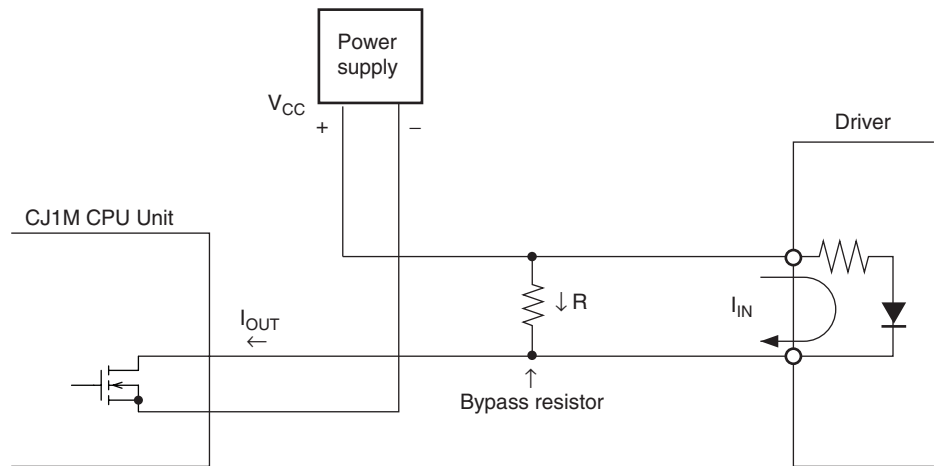

3-3-5 Error Counter Reset Output Connection Examples

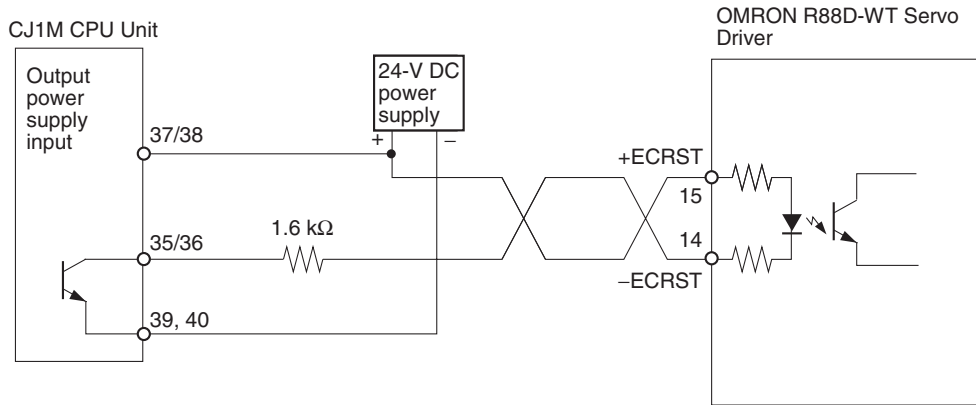
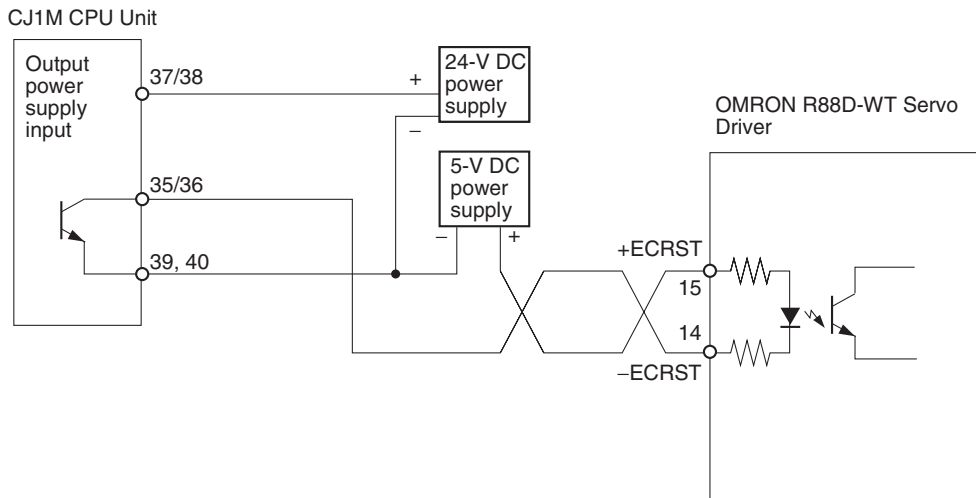

3-3-6 Motor Driver Connection Examples

This section provides examples of connections to pulse output 0. Refer to 3-2 *Wiring* for details when using pulse output 1.

- Note**
1. Any NC input terminals for unused inputs should be connected to the power supply and turned ON.
 2. Use shielded cable for connections to stepping motor drivers and servo drivers. Attach the shield to the FG terminals at both the NC Unit end and driver end of the cable.
 3. When using an open-collector connection, the cable to the motor driver must not exceed 3 m. When using a line driver connection, the cable to the motor driver must not exceed 5 m.

Connection Example for Operating Mode 0

In operating mode 0, the origin location is determined when the rising edge of the Origin Input Signal is detected (up-differentiation.) The Error Counter Reset Output and Positioning Completed Signal are not used.

In this example, a stepping motor driver is used and a sensor is connected to the Origin Input Signal terminal.

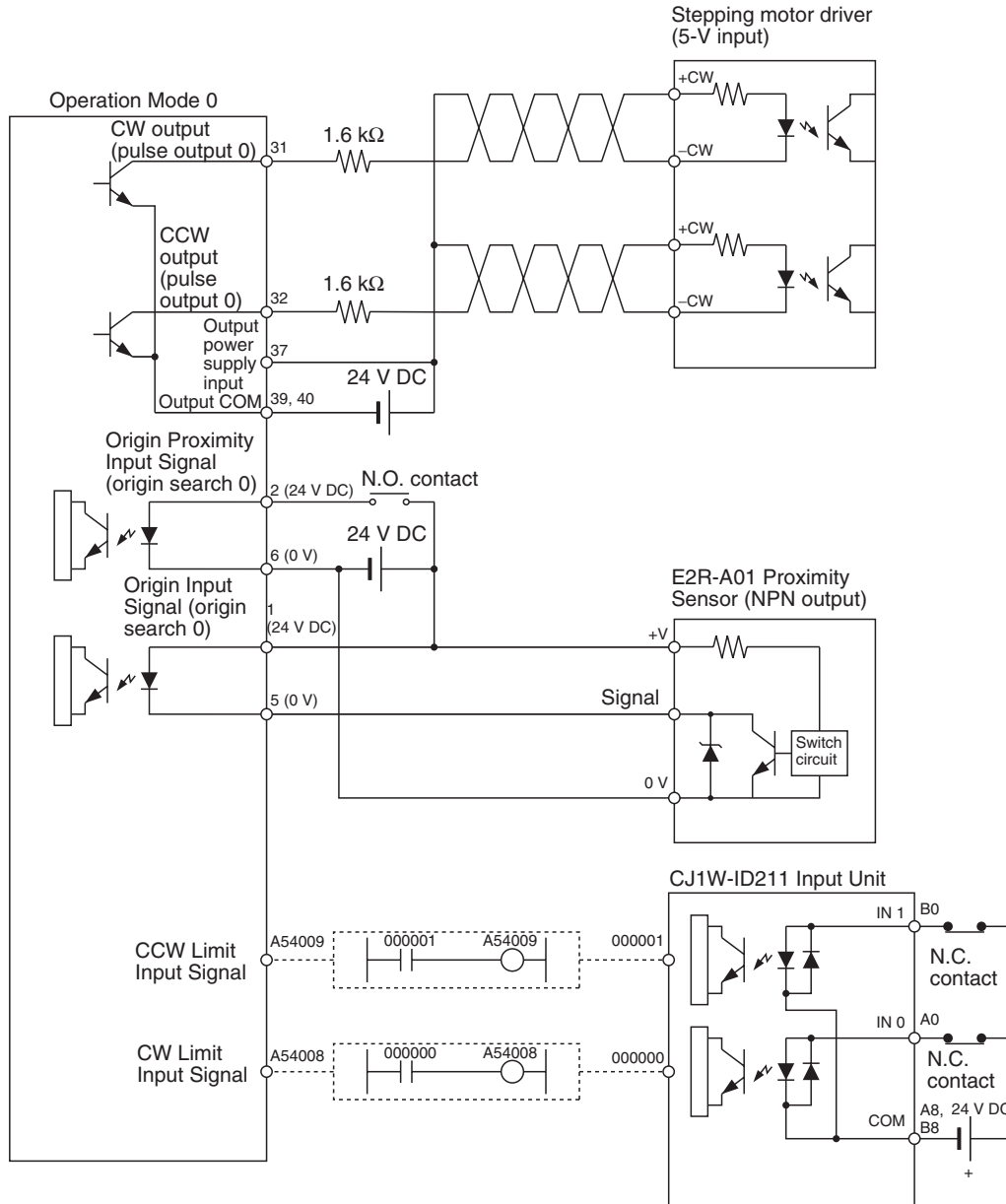

Origin Search Operation

The origin search operation is completed when the rising edge of the Origin Proximity Input Signal is detected and then the rising edge of the Origin Input Signal is detected.

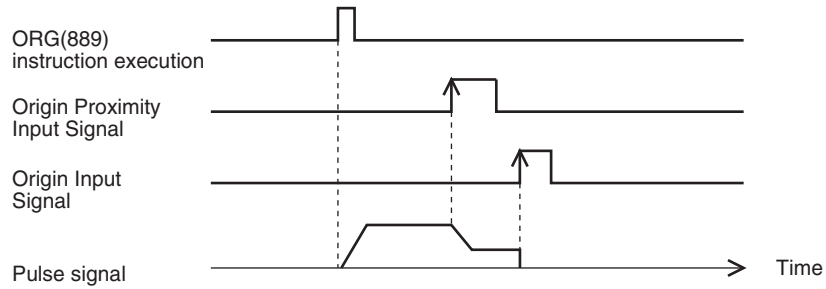

Example PLC Setup Settings

Programming Console address	Bits	Setting	Function
256	00 to 03	1 hex	Enable origin search function for pulse output 0.
257	00 to 03	0 hex	Operating Mode 0
	04 to 07	0 hex	Reverse mode 1
	08 to 11	1 hex	Read Origin Input Signal after Origin Proximity Input Signal goes from OFF to ON.
	12 to 15	0 hex	Search direction is CW.
268	00 to 03	0 hex	Limit Input Signal is a NC contact.
	04 to 07	1 hex	Origin Proximity Input Signal is a NO contact.
	08 to 11	1 hex	Origin Input Signal is a NO contact.
	12 to 15	0 hex	---

Operating Mode 1 Connection Example

In operating mode 1, the Error Counter Reset Output is turned ON when the origin location is determined by detection of the rising edge of the Origin Input Signal.

In this example, a servo driver is used and the encoder's phase-Z output is used as the Origin Input Signal terminal. The servo driver is an OMRON W-series Servo Driver.

Connecting an OMRON W-series Servo Driver

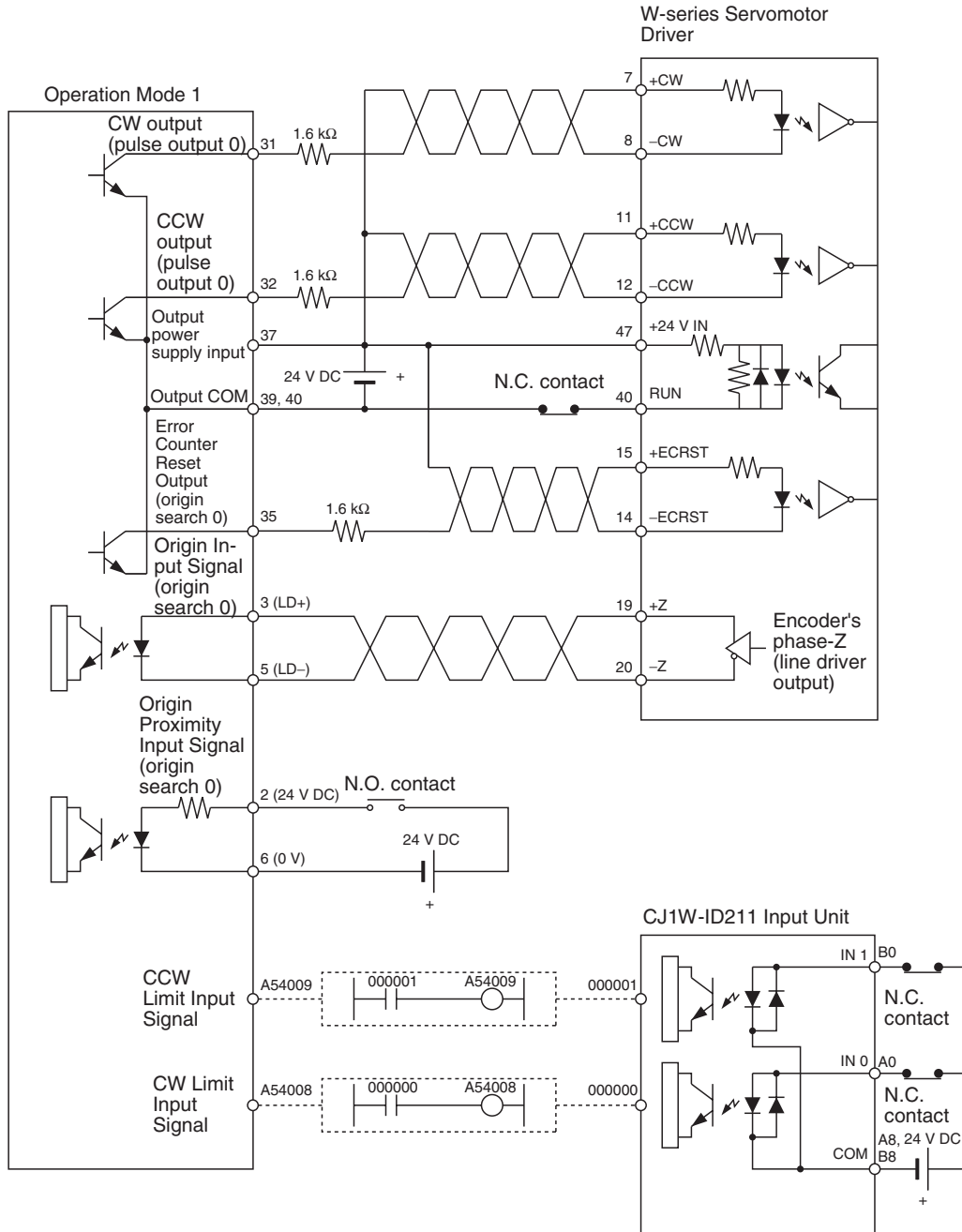

Connecting a SMARTSTEP A-series Servo Driver

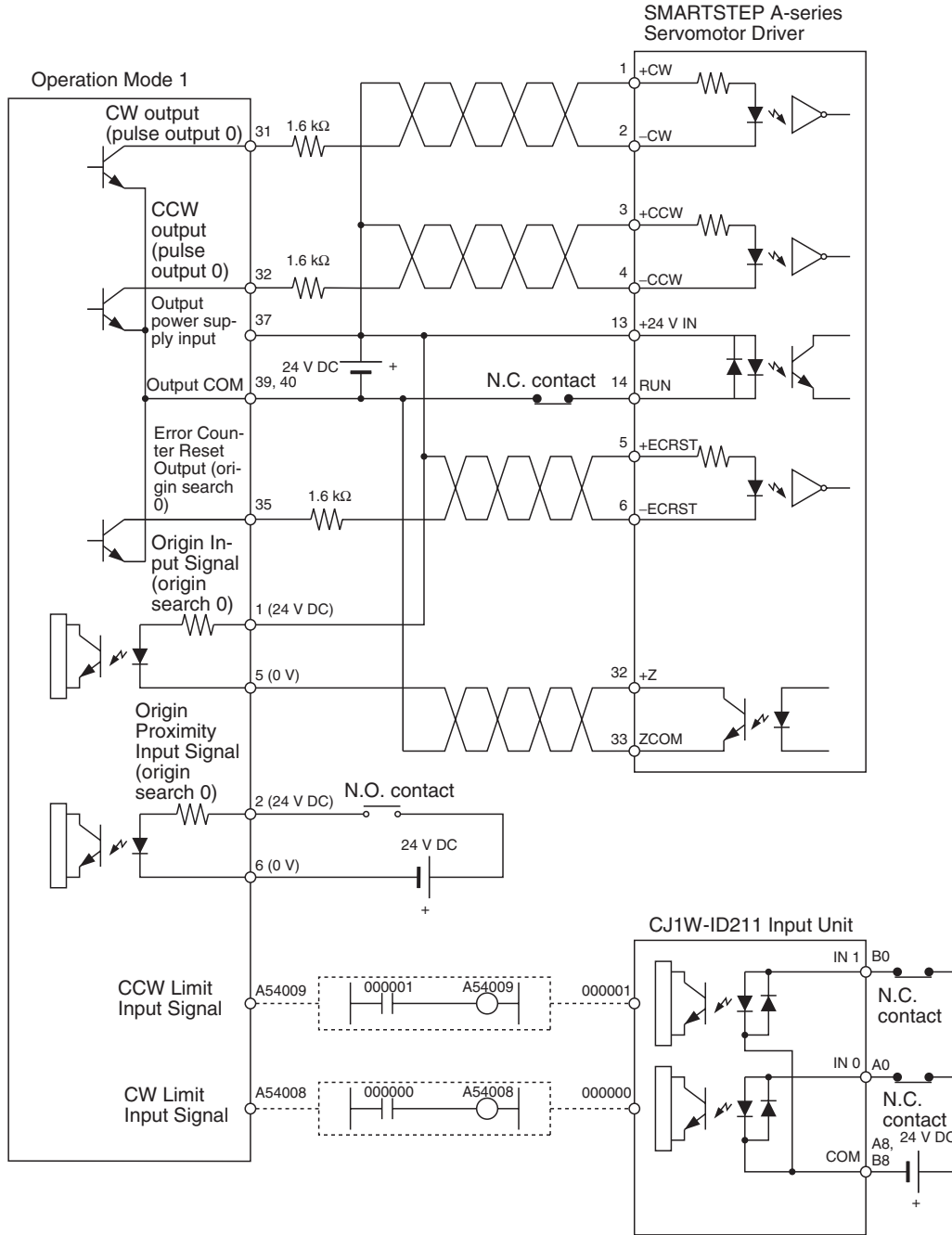

Origin Search Operation

The origin search operation is completed at the first phase-Z signal after the rising edge of the Origin Proximity Input Signal is detected, deceleration is completed, and the falling edge of the Origin Proximity Input Signal is detected.

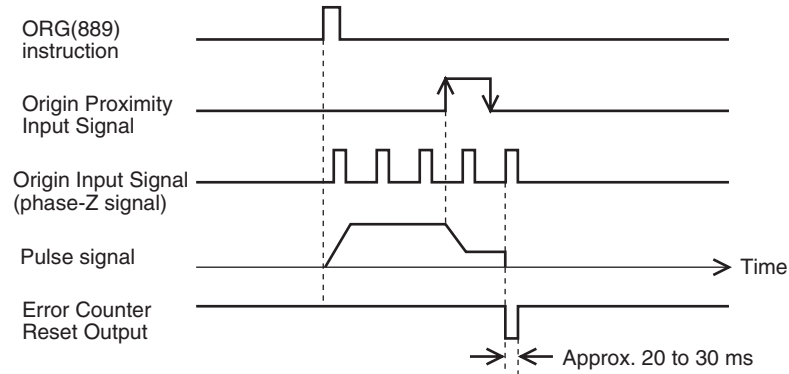

Example PLC Setup Settings

Programming Console address	Bits	Setting	Function
256	00 to 03	1 hex	Enable origin search function for pulse output 0.
257	00 to 03	1 hex	Operating mode 1
	04 to 07	0 hex	Reverse mode 1
	08 to 11	0 hex	Read Origin Input Signal after Origin Proximity Input Signal goes from OFF to ON to OFF again.
	12 to 15	0 hex	Search direction is CW.
268	00 to 03	0 hex	Limit Input Signal is a NC contact.
	04 to 07	1 hex	Origin Proximity Input Signal is a NO contact.
	08 to 11	1 hex	Origin Input Signal is a NO contact.
	12 to 15	0 hex	---

Operating Mode 2 Connection Example

Operating mode 2 is the same as operating mode 1 except that the servo driver's Positioning Completed Signal (INP) is used as the origin search's Positioning Completed Signal.

In this example, a servo driver is used and the encoder's phase-Z output is used as the Origin Input Signal terminal. The servo driver is an OMRON Servo Driver (W-series, U-series, or SMART STEP A-series).

Set the Servo Driver so that the Positioning Completed Signal is OFF when the motor is operating and ON when the motor is stopped. The origin search operation won't end if the Positioning Completed Signal is not connected correctly from the Servo Driver or is not set correctly.

Connecting an OMRON W-series or U-series (UP or UT) Servo Driver

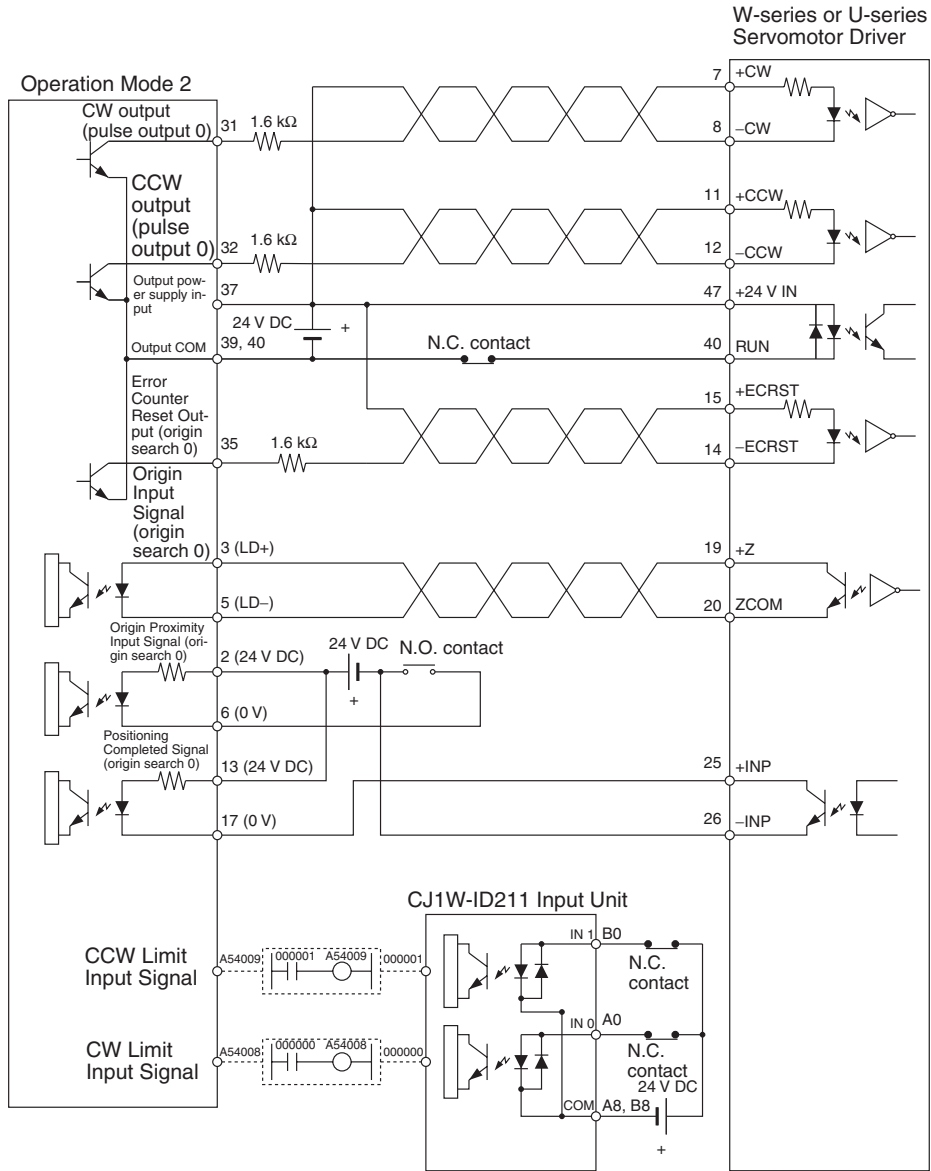

Connecting an OMRON U-series (UE) or SMART STEP A-series Servo Driver

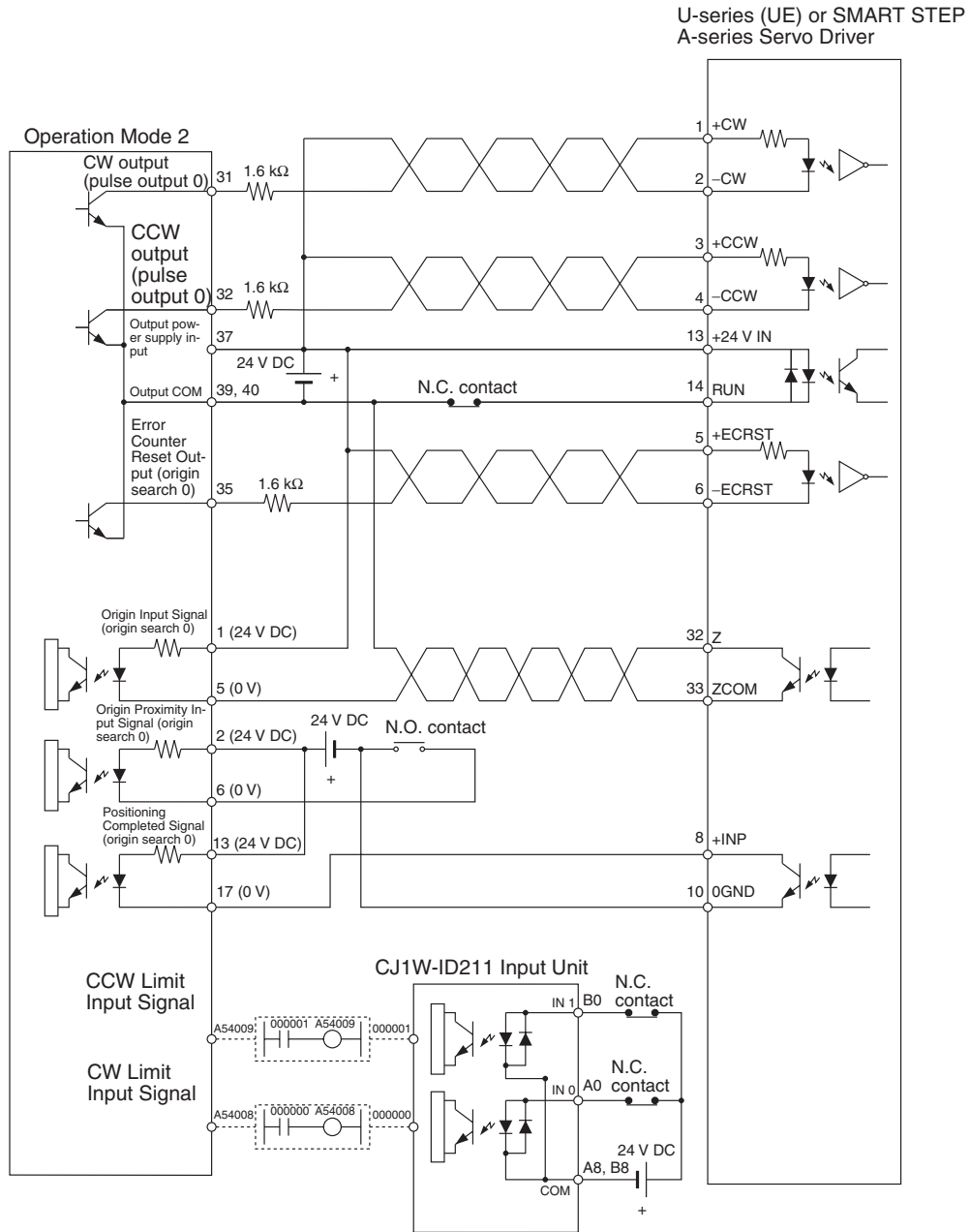

Origin Search Operation

The origin search operation is completed at the first phase-Z signal after the rising edge of the Origin Proximity Input Signal is detected, deceleration is completed, and the falling edge of the Origin Proximity Input Signal is detected.

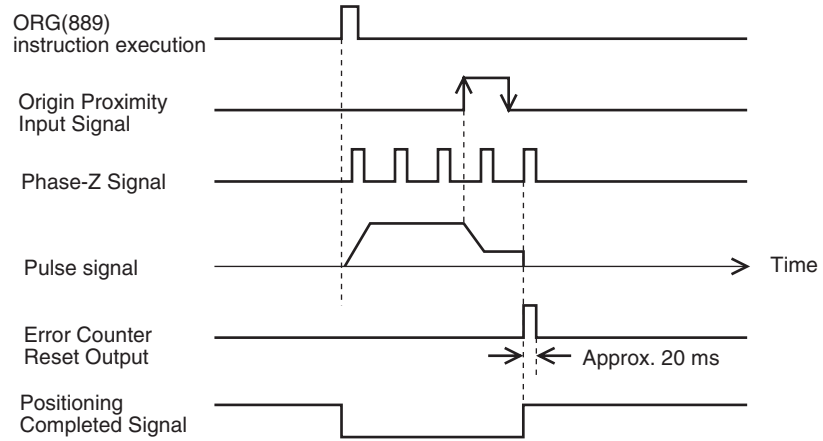

Example PLC Setup Settings

Programming Console address	Bits	Setting	Function
256	00 to 03	1 hex	Enable origin search function for pulse output 0.
257	00 to 03	2 hex	Operating mode 2
	04 to 07	0 hex	Reverse mode 1
	08 to 11	0 hex	Read Origin Input Signal after Origin Proximity Input Signal goes from OFF to ON to OFF again.
268	12 to 15	0 hex	Search direction is CW.
	00 to 03	0 hex	Limit Input Signal is a NC contact.
	04 to 07	1 hex	Origin Proximity Input Signal is a NO contact.
	08 to 11	1 hex	Origin Input Signal is a NO contact.
	12 to 15	0 hex	---

3-3-7 Variable Duty Ratio Pulse Output (PWM(891) Output) Connection Example

This example shows how to use pulse output 0 to control the brightness of a light bulb.

Refer to *Output Wiring Precautions* on page 34 for details on suppressing the load's inrush current and modify the circuit if necessary.

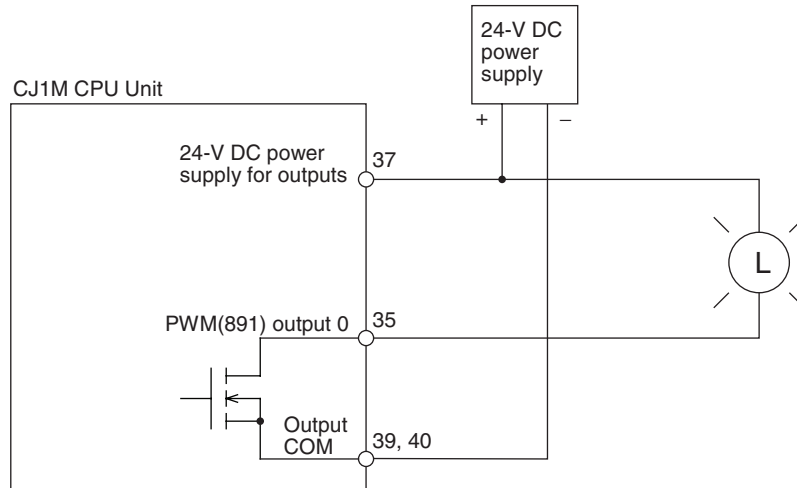

SECTION 4

Data Area Allocation and PLC Setup Settings

This section describes the allocation of words and bits for usage with the built-in I/O and PLC Setup settings related to built-in I/O.

4-1	Data Area Allocation for Built-in I/O	52
4-2	PLC Setup Settings	52
4-2-1	Built-in Inputs	52
4-2-2	Origin Search Function	57
4-2-3	Origin Return Function	66
4-3	Auxiliary Area Data Allocation	68
4-3-1	Auxiliary Area Flags and Bits for Built-in Inputs	68
4-3-2	Auxiliary Area Flags and Bits for Built-in Outputs	72
4-4	Flag Operations during Pulse Output	76

4-1 Data Area Allocation for Built-in I/O

I/O Code		IN0	IN1	IN2	IN3	IN4	IN5	IN6	IN7	IN8	IN9	OUT0	OUT1	OUT2	OUT3	OUT4	OUT5
Address		CIO 2960										CIO 2961					
Bit		00	01	02	03	04	05	06	07	08	09	00	01	02	03	04	05
Inputs	General-purpose inputs	General-purpose input 0	General-purpose input 1	General-purpose input 2	General-purpose input 3	General-purpose input 4	General-purpose input 5	General-purpose input 6	General-purpose input 7	General-purpose input 8	General-purpose input 9	---	---	---	---	---	---
	Interrupt inputs	Interrupt input 0	Interrupt input 1	Interrupt input 2	Interrupt input 3	---	---	---	---	---	---	---	---	---	---	---	---
	Quick-response inputs	Quick-response input 0	Quick-response input 1	Quick-response input 2	Quick-response input 3	---	---	---	---	---	---	---	---	---	---	---	---
	High-speed counters	---	---	High-speed counter 1 (phase-Z/reset)	High-speed counter 0 (phase-Z/reset)	---	---	High-speed counter 1 (phase-A, increment, or count input)	High-speed counter 1 (phase-B, decrement, or direction input)	High-speed counter 0 (phase-A, increment, or count input)	High-speed counter 0 (phase-B, decrement, or direction input)	---	---	---	---	---	---
Out-puts	General-purpose outputs	---	---	---	---	---	---	---	---	---	---	General-purpose output 0	General-purpose output 1	General-purpose output 2	General-purpose output 3	General-purpose output 4	General-purpose output 5
	Pulse out-puts	CW/CCW outputs	---	---	---	---	---	---	---	---	---	Pulse output 0 (CW)	Pulse output 0 (CCW)	Pulse output 1 (CW)	Pulse output 1 (CCW)	---	---
		Pulse + direction outputs	---	---	---	---	---	---	---	---	---	Pulse output 0 (pulse)	Pulse output 1 (pulse)	Pulse output 0 (direction)	Pulse output 1 (direction)	---	---
		Variable duty ratio outputs	---	---	---	---	---	---	---	---	---	---	---	---	---	---	PWM(891) output 0
Origin search	Origin search 0 (Origin Input Signal)	Origin search 0 (Origin Proximity Input Signal)	Origin search 1 (Origin Input Signal)	Origin search 1 (Origin Proximity Input Signal)	Origin search 0 (Positioning Completed Signal)	Origin search 1 (Positioning Completed Signal)	---	---	---	---	---	---	---	---	---	Origin search 0 (Error Counter Reset Output)	Origin search 1 (Error Counter Reset Output)

Note PWM(891) output 1 cannot be used on the CJ1M-CPU21.

4-2 PLC Setup Settings

4-2-1 Built-in Inputs

The following tables show the CX-Programmer's settings. These settings are for CJ1M CPU Units equipped with the built-in I/O functions.

Note CX-Programmer Tabs
 CX-Programmer Ver. 3.1 or lower: Built-in I/O Settings
 CX-Programmer Ver. 3.2 or higher: Built-in Input

High-speed Counter 0 Operation Settings

High-speed Counter 0 Enable/Disable

Programming Console setting address		Settings	Default	Function	Related Auxiliary Area flags/bits	Time when setting is read by CPU Unit
Word	Bits					
50	12 to 15	0 hex: Don't Use Counter. 1 hex*: Use Counter (60 kHz). 2 hex*: Use Counter (100 kHz).	0 hex	Specifies whether or not high-speed counter 0 is being used. Note When high-speed counter 0 is enabled (setting 1 or 2), the input operation settings for IN8 and IN9 are disabled. The input operation setting for IN3 is also disabled if the reset method is set to Phase-Z signal + software reset.	---	When power is turned ON

High-speed Counter 0 Counting Mode

Programming Console setting address		Settings	Default	Function	Related Auxiliary Area flags/ bits	Time when setting is read by CPU Unit
Word	Bits					
50	08 to 11	0 hex: Linear mode 1 hex: Ring mode	0 hex	Specifies the counting mode for high-speed counter 0.	---	When operation starts

High-speed Counter 0 Circular Max. Count (Ring Counter Maximum Value)

Programming Console setting address		Settings	Default	Function	Related Auxiliary Area flags/ bits	Time when setting is read by CPU Unit
Word	Bits					
51	00 to 15	00000000 to FFFFFFFF hex (See note.)	00000000 hex	Sets the max. ring count for high-speed counter 0. When the high-speed counter 0 counting mode is set to ring mode, the count will be reset to 0 automatically when the counter PV exceeds the max. ring count.	A270 (Rightmost 4 digits of the high-speed counter 0 PV)	When operation starts
52	00 to 15				A271 (Leftmost 4 digits of the high-speed counter 0 PV)	

High-speed Counter 0 Reset Method

Programming Console setting address		Settings	Default	Function	Related Auxiliary Area flags/ bits	Time when setting is read by CPU Unit
Word	Bits					
50	04 to 07	0 hex: Z phase, software reset (stop comparing) 1 hex: Software reset (stop comparing) 2 hex: Z phase, software reset (continue comparing) 3 hex: Software reset (continue comparing)	0 hex	Specifies the reset method for high-speed counter 0.	---	When power is turned ON

High-speed Counter 0 Pulse Input Setting (Pulse Input Mode)

Programming Console setting address		Settings	Default	Function	Related Auxiliary Area flags/ bits	Time when setting is read by CPU Unit
Word	Bits					
50	00 to 03	0 hex: Differential phase inputs 1 hex: Pulse + direction inputs 2 hex: Up/Down inputs 3 hex: Increment pulse input	0 hex	Specifies the pulse-input method for high-speed counter 0.	---	When power is turned ON

Note When the CX-Programmer is being used to make the setting, the setting is input in decimal.

High-speed Counter 1 Operation Settings

High-speed Counter 1 Enable/Disable

Programming Console setting address		Settings	Default	Function	Related Auxiliary Area flags/ bits	Time when setting is read by CPU Unit
Word	Bits					
53	12 to 15	0 hex: Don't Use Counter. 1 hex*: Use Counter (60 kHz). 2 hex*: Use Counter (100 kHz).	0 hex	Specifies whether or not high-speed counter 1 is being used. Note When high-speed counter 1 is enabled (setting 1 or 2), the input operation settings for IN6 and IN7 are disabled. The input operation setting for IN2 is also disabled if the reset method is set to Phase-Z signal + software reset.	---	When power is turned ON

High-speed Counter 1 Counting Mode

Programming Console setting address		Settings	Default	Function	Related Auxiliary Area flags/ bits	Time when setting is read by CPU Unit
Word	Bits					
53	08 to 11	0 hex: Linear mode 1 hex: Ring mode	0 hex	Specifies the counting mode for high-speed counter 1.	---	When operation starts

High-speed Counter 1 Circular Max. Count (Ring Counter Maximum Value)

Programming Console setting address		Settings	Default	Function	Related Auxiliary Area flags/ bits	Time when setting is read by CPU Unit
Word	Bits					
54	00 to 15	00000000 to FFFFFFFF hex (See note.)	00000000 hex	Sets the max. ring count for high-speed counter 1. When the high-speed counter 1 counting mode is set to ring mode, the count will be reset to 0 automatically when the counter PV exceeds the max. ring count.	A272 (Rightmost 4 digits of the high-speed counter 1 PV)	When operation starts
55	00 to 15				A273 (Leftmost 4 digits of the high-speed counter 1 PV)	

High-speed Counter 1 Reset Method

Programming Console setting address		Settings	Default	Function	Related Auxiliary Area flags/ bits	Time when setting is read by CPU Unit
Word	Bits					
53	04 to 07	0 hex: Z phase, software reset (stop comparing) 1 hex: Software reset (stop comparing) 2 hex: Z phase, software reset (continue comparing) 3 hex: Software reset (continue comparing)	0 hex	Specifies the reset method for high-speed counter 1.	---	When power is turned ON

High-speed Counter 1 Pulse Input Setting (Pulse Input Mode)

Programming Console setting address		Settings	Default	Function	Related Auxiliary Area flags/ bits	Time when setting is read by CPU Unit
Word	Bits					
53	00 to 03	0 hex: Differential phase inputs 1 hex: Pulse + direction inputs 2 hex: Up/Down inputs 3 hex: Increment pulse input	0 hex	Specifies the pulse-input method for high-speed counter 1.	---	When power is turned ON

Note When the CX-Programmer is being used to make the setting, the setting is input in decimal.

Input Operation Settings for Built-in Inputs IN0 to IN3

Input Operation Setting for IN0

Programming Console setting address		Settings	Default	Function	Related Auxiliary Area flags/ bits	Time when setting is read by CPU Unit
Word	Bits					
60	00 to 03	0 hex: Normal (General-purpose input) 1 hex: Interrupt (Interrupt input) (See note.) 2 hex: Quick (Quick-response input)	0 hex	Specifies the kind of input that is being received at built-in input IN0.	---	When power is turned ON

Note When IN0 is set as an interrupt input (1 hex), use the MSKS(690) instruction to select direct mode or counter mode operation.

Input Operation Setting for IN1

Programming Console setting address		Settings	Default	Function	Related Auxiliary Area flags/ bits	Time when setting is read by CPU Unit
Word	Bits					
60	04 to 07	0 hex: Normal (General-purpose input) 1 hex: Interrupt (Interrupt input) (See note.) 2 hex: Quick (Quick-response input)	0 hex	Specifies the kind of input that is being received at built-in input IN1.	---	When power is turned ON

Note When IN1 is set as an interrupt input (1 hex), use the MSKS(690) instruction to select direct mode or counter mode operation.

Input Operation Setting for IN2

Programming Console setting address		Settings	Default	Function	Related Auxiliary Area flags/ bits	Time when setting is read by CPU Unit
Word	Bits					
60	08 to 11	0 hex: Normal (General-purpose input) 1 hex: Interrupt (Interrupt input) (See note.) 2 hex: Quick (Quick-response input)	0 hex	Specifies the kind of input that is being received at built-in input IN2. Note The input operation setting for IN2 is disabled when high-speed counter 1 is being used and the reset method is set to Phase-Z signal + software reset.	---	When power is turned ON

Note When IN2 is set as an interrupt input (1 hex), use the MSKS(690) instruction to select direct mode or counter mode operation.

Input Operation Setting for IN3

Programming Console setting address		Settings	Default	Function	Related Auxiliary Area flags/ bits	Time when setting is read by CPU Unit
Word	Bits					
60	12 to 15	0 hex: Normal (General-purpose input) 1 hex: Interrupt (Interrupt input) (See note.) 2 hex: Quick (Quick-response input)	0 hex	Specifies the kind of input that is being received at built-in input IN3 Note The input operation setting for IN3 is disabled when high-speed counter 0 is being used and the reset method is set to Phase-Z signal + software reset.	---	When power is turned ON

Note When IN3 is set as an interrupt input (1 hex), use the MSKS(690) instruction to select direct mode or counter mode operation.

Input Time Constant Setting for the General-purpose Inputs

Programming Console setting address		Settings	Default	Function	Related Auxiliary Area flags/ bits	Time when setting is read by CPU Unit
Word	Bits					
61	00 to 07	00 hex: Default (8 ms) 10 hex: 0 ms (no filter) 11 hex: 0.5 ms 12 hex: 1 ms 13 hex: 2 ms 14 hex: 4 ms 15 hex: 8 ms 16 hex: 16 ms 17 hex: 32 ms	0 hex	Specifies the input time constant for general-purpose inputs IN0 to IN9. Note This setting has no effect on inputs set as interrupt inputs, quick-response inputs, or high-speed counters.	---	When operation starts

4-2-2 Origin Search Function

The following tables show the settings for the origin search function in the CX-Programmer. These settings are for CJ1M CPU Units equipped with the built-in I/O functions.

Note CX-Programmer Tabs
 CX-Programmer Ver. 3.1 or lower: Define Origin Operation Settings Field of Define Origin
 CX-Programmer Ver. 3.2 or higher: Pulse Output 0

Pulse Output 0 Settings

Pulse Output 0 Use Origin Operation Settings (Origin Search Function Enable/Disable)

Programming Console setting address		Settings	Default	Function	Related Auxiliary Area flags/ bits	Time when setting is read by CPU Unit
Word	Bits					
256	00 to 03	0 hex: Disabled 1 hex*: Enabled	0 hex	Specifies whether or not the origin search function is used for pulse output 0. Note Interrupt inputs 0 and 1 and PWM(891) output 0 cannot be used when the origin search function is enabled (setting 1) for pulse output 0. High-speed counters 0 and 1 can be used.	---	When power is turned ON

Pulse Output 0 Limit Input Signal Operation (CJ1M CPU Unit Ver. 2.0 or Later)

Programming Console setting address		Settings	Default	Function	Related Auxiliary Area flags/ bits	Time when setting is read by CPU Unit
Word	Bits					
256	04 to 07	0 hex: Search only 1 hex: Always	0 hex	Specifies whether to use the CW/CCW limit input signals (reflected in A54008, A54009, A54108, and A54109) only for origin searches or for all pulse output functions.	---	When power is turned ON

Pulse Output 0 Speed Curve (CJ1M CPU Unit Ver. 2.0 or Later)

Programming Console setting address		Settings	Default	Function	Related Auxiliary Area flags/ bits	Time when setting is read by CPU Unit
Word	Bits					
256	12 to 15	0 hex: Trapezium (linear) 1 hex: S-shaped	0 hex	Specifies whether to use S-curve or linear acceleration/deceleration rates for pulse outputs with acceleration/ deceleration.	---	When power is turned ON

Pulse Output 0 Origin Search Direction Setting

Programming Console setting address		Settings	Default	Function	Related Auxiliary Area flags/ bits	Time when setting is read by CPU Unit
Word	Bits					
257	12 to 15	0 hex: CW direction 1 hex: CCW direction	0 hex	Specifies the origin search direction for pulse output 0.	---	When operation starts

Pulse Output 0 Origin Detection Method

Programming Console setting address		Settings	Default	Function	Related Auxiliary Area flags/ bits	Time when setting is read by CPU Unit
Word	Bits					
257	08 to 11	0 hex: Method 0 (Origin detection method 0) 1 hex: Method 1 (Origin detection method 1) 2 hex: Method 2 (Origin detection method 2)	0 hex	Specifies the origin detection method for pulse output 0.	---	When operation starts

Pulse Output 0 Origin Search Operation Setting

Programming Console setting address		Settings	Default	Function	Related Auxiliary Area flags/ bits	Time when setting is read by CPU Unit
Word	Bits					
257	04 to 07	0 hex: Inverse 1 (Reversal mode 1) 1 hex: Inverse 2 (Reversal mode 2)	0 hex	Specifies the origin search operation for pulse output 0.	---	When operation starts

Pulse Output 0 Origin Search Operating Mode

Programming Console setting address		Settings	Default	Function	Related Auxiliary Area flags/ bits	Time when setting is read by CPU Unit
Word	Bits					
257	00 to 03	0 hex: Mode 0 1 hex: Mode 1 2 hex: Mode 2	0 hex	Specifies the origin search mode for pulse output 0.	---	When operation starts

Pulse Output 0 Undefine Origin Setting (CJ1M CPU Unit Ver. 2.0 or Later)

Programming Console setting address		Settings	Default	Function	Related Auxiliary Area flags/ bits	Time when setting is read by CPU Unit
Word	Bits					
268	12 to 15	0 hex: Hold 1 hex: Undefine	0 hex	Specifies whether to hold the origin setting when the CW/CCW limit input signal is input during execution of an origin search or pulse output function.	---	When operation starts

Pulse Output 0 Origin Input Signal Type

Programming Console setting address		Settings	Default	Function	Related Auxiliary Area flags/ bits	Time when setting is read by CPU Unit
Word	Bits					
268	08 to 11	0 hex: NC 1 hex: NO	0 hex	Specifies whether the Origin Input Signal for pulse output 0 is normally closed or normally open.	---	When operation starts

Pulse Output 0 Origin Proximity Input Signal Type

Programming Console setting address		Settings	Default	Function	Related Auxiliary Area flags/ bits	Time when setting is read by CPU Unit
Word	Bits					
268	04 to 07	0 hex: NC 1 hex: NO	0 hex	Specifies whether the Origin Proximity Input Signal for pulse output 0 is normally closed or normally open.	---	When operation starts

Pulse Output 0 Limit Input Signal Type

Programming Console setting address		Settings	Default	Function	Related Auxiliary Area flags/ bits	Time when setting is read by CPU Unit
Word	Bits					
268	00 to 03	0 hex: NC 1 hex: NO	0 hex	Specifies whether the limit input signal for pulse output 0 is normally closed or normally open.	---	When operation starts

Pulse Output 0 Origin Search/Return Initial Speed

Programming Console setting address		Settings	Default	Function	Related Auxiliary Area flags/ bits	Time when setting is read by CPU Unit
Word	Bits					
258	00 to 15	00000000 to 000186A0 hex (See note.)	00000000 hex	Specifies the starting speed (0 to 100,000 pps) for the pulse output 0 origin search and origin return operations.	---	When operation starts
259	00 to 15					

Note When the CX-Programmer is being used to make the setting, the setting is input in decimal.

Pulse Output 0 Origin Search High Speed

Programming Console setting address		Settings	Default	Function	Related Auxiliary Area flags/ bits	Time when setting is read by CPU Unit
Word	Bits					
260	00 to 15	00000001 to 000186A0 hex (See note.)	00000000 hex	Specifies the high speed setting (1 to 100,000 pps) for pulse output 0 origin search operation.	---	When operation starts
261	00 to 15					

Note When the CX-Programmer is being used to make the setting, the setting is input in decimal.

Pulse Output 0 Origin Search Proximity Speed

Programming Console setting address		Settings	Default	Function	Related Auxiliary Area flags/ bits	Time when setting is read by CPU Unit
Word	Bits					
262	00 to 15	00000001 to 000186A0 hex (See note.)	00000000 hex	Specifies the proximity speed setting (1 to 100,000 pps) for pulse output 0 origin search operation.	---	When operation starts
263	00 to 15					

Note When the CX-Programmer is being used to make the setting, the setting is input in decimal.

Pulse Output 0 Search Compensation Value (Origin Compensation)

Programming Console setting address		Settings	Default	Function	Related Auxiliary Area flags/ bits	Time when setting is read by CPU Unit
Word	Bits					
264	00 to 15	80000000 to 7FFFFFFF hex (See note.)	---	Sets the pulse output 0 origin compensation (-2,147,483,648 to 2,147,483,647).	---	When operation starts
265	00 to 15					

Note When the CX-Programmer is being used to make the setting, the setting is input in decimal.

Pulse Output 0 Origin Search Acceleration Rate

Programming Console setting address		Settings	Default	Function	Related Auxiliary Area flags/ bits	Time when setting is read by CPU Unit
Word	Bits					
266	00 to 15	Pre-Ver. 2.0 CPU Units: 0001 to 07D0 hex CPU Units Ver. 2.0 or later: 0001 to FFFF hex (See note.)	---	Sets the origin search acceleration rate for pulse output 0. Pre-Ver. 2.0 CPU Units: 1 to 2,000 pulses/4 ms CPU Units Ver. 2.0 or later: 1 to 65,535 pulses/4 ms	---	When operation starts

Note When the CX-Programmer is being used to make the setting, the setting is input in decimal.

Pulse Output 0 Origin Search Deceleration Rate

Programming Console setting address		Settings	Default	Function	Related Auxiliary Area flags/ bits	Time when setting is read by CPU Unit
Word	Bits					
267	00 to 15	Pre-Ver. 2.0 CPU Units: 0001 to 07D0 hex CPU Units Ver. 2.0 or later: 0001 to FFFF hex (See note.)	---	Sets the origin search deceleration rate for pulse output 0. Pre-Ver. 2.0 CPU Units: 1 to 2,000 pulses/4 ms CPU Units Ver. 2.0 or later: 1 to 65,535 pulses/4 ms	---	When operation starts

Note When the CX-Programmer is being used to make the setting, the setting is input in decimal.

Pulse Output 0 Positioning Monitor Time

Programming Console setting address		Settings	Default	Function	Related Auxiliary Area flags/ bits	Time when setting is read by CPU Unit
Word	Bits					
269	00 to 15	0000 to 270F hex (See note.)	0000 hex	Specifies the positioning monitor time (0 to 9,999 ms) for pulse output 0.	---	When operation starts

Note When the CX-Programmer is being used to make the setting, the setting is input in decimal.

Pulse Output 1 Settings

Note CX-Programmer Tabs
 CX-Programmer Ver. 3.1 or lower: Define Origin Operation Settings Field of Define Origin 2
 CX-Programmer Ver. 3.2 or higher: Pulse Output 1

Pulse Output 1 Use Origin Operation Settings (Origin Search Function Enable/Disable)

Programming Console setting address		Settings	Default	Function	Related Auxiliary Area flags/ bits	Time when setting is read by CPU Unit
Word	Bits					
274	00 to 03	0 hex: Disabled 1 hex*: Enabled	0 hex	Specifies whether or not the origin search function is used for pulse output 1. Note Interrupt inputs 2 and 3 and PWM(891) output 1 cannot be used when the origin search function is enabled (setting 1) for pulse output 1. High-speed counters 0 and 1 can be used.	---	When power is turned ON

Pulse Output 1 Limit Input Signal Operation (CJ1M CPU Unit Ver. 2.0 or Later)

Programming Console setting address		Settings	Default	Function	Related Auxiliary Area flags/ bits	Time when setting is read by CPU Unit
Word	Bits					
274	04 to 07	0 hex: Search only 1 hex: Always	0 hex	Specifies whether to use the CW/CCW limit input signals (reflected in A54008, A54009, A54108, and A54109) only for origin searches or for all pulse output functions.	---	When power is turned ON

Pulse Output 1 Speed Curve (CJ1M CPU Unit Ver. 2.0 or Later)

Programming Console setting address		Settings	Default	Function	Related Auxiliary Area flags/ bits	Time when setting is read by CPU Unit
Word	Bits					
274	12 to 15	0 hex: Trapezium (linear) 1 hex: S-shaped	0 hex	Specifies whether to use S-curve or linear acceleration/deceleration rates for pulse outputs with acceleration/deceleration.	---	When power is turned ON

Pulse Output 1 Origin Search Direction Setting

Programming Console setting address		Settings	Default	Function	Related Auxiliary Area flags/ bits	Time when setting is read by CPU Unit
Word	Bits					
275	12 to 15	0 hex: CW direction 1 hex: CCW direction	0 hex	Specifies the origin search direction for pulse output 1.	---	When operation starts

Pulse Output 1 Origin Detection Method

Programming Console setting address		Settings	Default	Function	Related Auxiliary Area flags/ bits	Time when setting is read by CPU Unit
Word	Bits					
275	08 to 11	0 hex: Method 0 (Origin detection method 0) 1 hex: Method 1 (Origin detection method 1) 2 hex: Method 2 (Origin detection method 2)	0 hex	Specifies the origin detection method for pulse output 1.	---	When operation starts

Pulse Output 1 Origin Search Operation Setting

Programming Console setting address		Settings	Default	Function	Related Auxiliary Area flags/ bits	Time when setting is read by CPU Unit
Word	Bits					
275	04 to 07	0 hex: Inverse 1 (Reversal mode 1) 1 hex: Inverse 2 (Reversal mode 2)	0 hex	Specifies the origin search operation for pulse output 1.	---	When operation starts

Pulse Output 1 Origin Search Operating Mode

Programming Console setting address		Settings	Default	Function	Related Auxiliary Area flags/ bits	Time when setting is read by CPU Unit
Word	Bits					
275	00 to 03	0 hex: Mode 0 1 hex: Mode 1 2 hex: Mode 2	0 hex	Specifies the origin search mode for pulse output 1.	---	When operation starts

Pulse Output 1 Undefine Origin Setting (CJ1M CPU Unit Ver. 2.0 or Later)

Programming Console setting address		Settings	Default	Function	Related Auxiliary Area flags/ bits	Time when setting is read by CPU Unit
Word	Bits					
286	12 to 15	0 hex: Hold 1 hex: Undefine	0 hex	Specifies whether to hold the origin setting when the CW/CCW limit input signal is input during execution of an origin search or pulse output function.	---	When operation starts

Pulse Output 1 Origin Input Signal Type

Programming Console setting address		Settings	Default	Function	Related Auxiliary Area flags/ bits	Time when setting is read by CPU Unit
Word	Bits					
286	08 to 11	0 hex: NC 1 hex: NO	0 hex	Specifies whether the Origin Input Signal for pulse output 1 is normally closed or normally open.	---	When operation starts

Pulse Output 1 Origin Proximity Input Signal Type

Programming Console setting address		Settings	Default	Function	Related Auxiliary Area flags/ bits	Time when setting is read by CPU Unit
Word	Bits					
286	04 to 07	0 hex: NC 1 hex: NO	0 hex	Specifies whether the Origin Proximity Input Signal for pulse output 1 is normally closed or normally open.	---	When operation starts

Pulse Output 1 Limit Input Signal Type

Programming Console setting address		Settings	Default	Function	Related Auxiliary Area flags/ bits	Time when setting is read by CPU Unit
Word	Bits					
286	00 to 03	0 hex: NC 1 hex: NO	0 hex	Specifies whether the limit input signal for pulse output 1 is normally closed or normally open.	---	When operation starts

Pulse Output 1 Origin Search/Return Initial Speed

Programming Console setting address		Settings	Default	Function	Related Auxiliary Area flags/ bits	Time when setting is read by CPU Unit
Word	Bits					
276	00 to 15	00000000 to 000186A0 hex (See note.)	00000000 hex	Specifies the starting speed (0 to 100,000 pps) for the pulse output 1 origin search and origin return operations.	---	When operation starts
277	00 to 15					

Note When the CX-Programmer is being used to make the setting, the setting is input in decimal.

Pulse Output 1 Origin Search High Speed

Programming Console setting address		Settings	Default	Function	Related Auxiliary Area flags/ bits	Time when setting is read by CPU Unit
Word	Bits					
278	00 to 15	00000001 to 000186A0 hex (See note.)	00000001 hex	Specifies the high speed setting (1 to 100,000 pps) for pulse output 1 origin search operation.	---	When operation starts
279	00 to 15					

Note When the CX-Programmer is being used to make the setting, the setting is input in decimal.

Pulse Output 1 Origin Search Proximity Speed

Programming Console setting address		Settings	Default	Function	Related Auxiliary Area flags/ bits	Time when setting is read by CPU Unit
Word	Bits					
280	00 to 15	00000001 to 000186A0 hex (See note.)	00000000 hex	Specifies the proximity speed setting (1 to 100,000 pps) for pulse output 1 origin search operation.	---	When operation starts
281	00 to 15					

Note When the CX-Programmer is being used to make the setting, the setting is input in decimal.

Pulse Output 1 Search Compensation Value 1 (Origin Compensation)

Programming Console setting address		Settings	Default	Function	Related Auxiliary Area flags/ bits	Time when setting is read by CPU Unit
Word	Bits					
282	00 to 15	80000000 to 7FFFFFFF hex (See note.)	---	Sets the pulse output 1 origin compensation (-2,147,483,648 to 2,147,483,647).	---	When operation starts
283	00 to 15					

Note When the CX-Programmer is being used to make the setting, the setting is input in decimal.

Pulse Output 1 Origin Search Acceleration Rate

Programming Console setting address		Settings	Default	Function	Related Auxiliary Area flags/ bits	Time when setting is read by CPU Unit
Word	Bits					
284	00 to 15	Pre-Ver. 2.0 CPU Units: 0001 to 07D0 hex CPU Units Ver. 2.0 or later: 0001 to FFFF hex (See note.)	---	Sets the origin search acceleration rate for pulse output 0. Pre-Ver. 2.0 CPU Units: 1 to 2,000 pulses/4 ms CPU Units Ver. 2.0 or later: 1 to 65,535 pulses/4 ms	---	When operation starts

Note When the CX-Programmer is being used to make the setting, the setting is input in decimal.

Pulse Output 1 Origin Search Deceleration Rate

Programming Console setting address		Settings	Default	Function	Related Auxiliary Area flags/ bits	Time when setting is read by CPU Unit
Word	Bits					
285	00 to 15	Pre-Ver. 2.0 CPU Units: 0001 to 07D0 hex CPU Units Ver. 2.0 or later: 0001 to FFFF hex (See note.)	---	Sets the origin search deceleration rate for pulse output 0. Pre-Ver. 2.0 CPU Units: 1 to 2,000 pulses/4 ms CPU Units Ver. 2.0 or later: 1 to 65,535 pulses/4 ms	---	When operation starts

Note When the CX-Programmer is being used to make the setting, the setting is input in decimal.

Pulse Output 1 Positioning Monitor Time

Programming Console setting address		Settings	Default	Function	Related Auxiliary Area flags/ bits	Time when setting is read by CPU Unit
Word	Bits					
287	00 to 15	0000 to 270F hex (See note.)	0000 hex	Specifies the positioning monitor time (0 to 9,999 ms) for pulse output 1.	---	When operation starts

Note When the CX-Programmer is being used to make the setting, the setting is input in decimal.

4-2-3 Origin Return Function

The following tables show the settings for the origin return function in the CX-Programmer. These settings are for CJ1M CPU Units equipped with the built-in I/O functions.

Note CX-Programmer Tabs
 CX-Programmer Ver. 3.1 or lower: Define Origin Operation Settings Field of Define Origin 1
 CX-Programmer Ver. 3.2 or higher: Pulse Output 0

Pulse Output 0 Settings

Speed (Target Speed for Pulse Output 0 Origin Return)

Programming Console setting address		Settings	Default	Function	Related Auxiliary Area flags/ bits	Time when setting is read by CPU Unit
Word	Bits					
270	00 to 15	00000001 to 000186A0 hex (See note.)	00000000 hex	Specifies the target speed (1 to 100,000 pps) for pulse output 0 origin return operation.	---	When operation starts
271	00 to 15					

Note When the CX-Programmer is being used to make the setting, the setting is input in decimal.

Acceleration Rate (Pulse Output 0 Origin Return Acceleration Rate)

Programming Console setting address		Settings	Default	Function	Related Auxiliary Area flags/ bits	Time when setting is read by CPU Unit
Word	Bits					
272	00 to 15	Pre-Ver. 2.0 CPU Units: 0001 to 07D0 hex CPU Units Ver. 2.0 or later: 0001 to FFFF hex (See note.)	0000 hex	Sets the origin search acceleration rate for pulse output 0. Pre-Ver. 2.0 CPU Units: 1 to 2,000 pulses/4 ms CPU Units Ver. 2.0 or later: 1 to 65,535 pulses/4 ms	---	When operation starts

Note When the CX-Programmer is being used to make the setting, the setting is input in decimal.

Deceleration Rate (Pulse Output 0 Origin Return Deceleration Rate)

Programming Console setting address		Settings	Default	Function	Related Auxiliary Area flags/ bits	Time when setting is read by CPU Unit
Word	Bits					
273	00 to 15	Pre-Ver. 2.0 CPU Units: 0001 to 07D0 hex CPU Units Ver. 2.0 or later: 0001 to FFFF hex (See note.)	0000 hex	Sets the origin search deceleration rate for pulse output 0. Pre-Ver. 2.0 CPU Units: 1 to 2,000 pulses/4 ms CPU Units Ver. 2.0 or later: 1 to 65,535 pulses/4 ms	---	When operation starts

Note When the CX-Programmer is being used to make the setting, the setting is input in decimal.

Pulse Output 1 Settings

Note CX-Programmer Tabs
 CX-Programmer Ver. 3.1 or lower: Define Origin Operation Settings Field of Define Origin 2
 CX-Programmer Ver. 3.2 or higher: Pulse Output 1

Speed (Target Speed for Pulse Output 1 Origin Return)

Programming Console setting address		Settings	Default	Function	Related Auxiliary Area flags/ bits	Time when setting is read by CPU Unit
Word	Bits					
288	00 to 15	00000001 to 000186A0 hex (See note.)	00000000 hex	Specifies the target speed (1 to 100,000 pps) for pulse output 1 origin return operation.	---	When operation starts
289	00 to 15					

Note When the CX-Programmer is being used to make the setting, the setting is input in decimal.

Acceleration Rate (Pulse Output 1 Origin Return Acceleration Rate)

Programming Console setting address		Settings	Default	Function	Related Auxiliary Area flags/ bits	Time when setting is read by CPU Unit
Word	Bits					
290	00 to 15	Pre-Ver. 2.0 CPU Units: 0001 to 07D0 hex CPU Units Ver. 2.0 or later: 0001 to FFFF hex (See note.)	0000 hex	Sets the origin search acceleration rate for pulse output 0. Pre-Ver. 2.0 CPU Units: 1 to 2,000 pulses/4 ms CPU Units Ver. 2.0 or later: 1 to 65,535 pulses/4 ms	---	When operation starts

Note When the CX-Programmer is being used to make the setting, the setting is input in decimal.

Deceleration (Pulse Output 1 Origin Return Deceleration Rate)

Programming Console setting address		Settings	Default	Function	Related Auxiliary Area flags/ bits	Time when setting is read by CPU Unit
Word	Bits					
291	00 to 15	Pre-Ver. 2.0 CPU Units: 0001 to 07D0 hex CPU Units Ver. 2.0 or later: 0001 to FFFF hex (See note.)	0000 hex	Sets the origin search deceleration rate for pulse output 0. Pre-Ver. 2.0 CPU Units: 1 to 2,000 pulses/4 ms CPU Units Ver. 2.0 or later: 1 to 65,535 pulses/4 ms	---	When operation starts

Note When the CX-Programmer is being used to make the setting, the setting is input in decimal.

4-3 Auxiliary Area Data Allocation

4-3-1 Auxiliary Area Flags and Bits for Built-in Inputs

The following tables show the Auxiliary Area words and bits that are related to the CJ1M CPU Unit's built-in inputs. These allocations apply to CPU Units equipped with the built-in I/O functions only.

Interrupt Inputs

Name	Address	Description	Read/Write	Times when data is accessed
Interrupt Counter 0 Counter SV	A532	Used for interrupt input 0 in counter mode. Sets the count value at which the interrupt task will start. Interrupt task 140 will start when interrupt counter 0 has counted this number of pulses.	Read/Write	<ul style="list-style-type: none"> Retained when power is turned ON. Retained when operation starts.
Interrupt Counter 1 Counter SV	A533	Used for interrupt input 1 in counter mode. Sets the count value at which the interrupt task will start. Interrupt task 141 will start when interrupt counter 1 has counted this number of pulses.	Read/Write	
Interrupt Counter 2 Counter SV	A534	Used for interrupt input 2 in counter mode. Sets the count value at which the interrupt task will start. Interrupt task 142 will start when interrupt counter 2 has counted this number of pulses.	Read/Write	
Interrupt Counter 3 Counter SV	A535	Used for interrupt input 3 in counter mode. Sets the count value at which the interrupt task will start. Interrupt task 143 will start when interrupt counter 3 has counted this number of pulses.	Read/Write	
Interrupt Counter 0 Counter PV	A536	These words contain the interrupt counter PVs for interrupt inputs operating in counter mode. In increment mode, the counter PV starts incrementing from 0. When the counter PV reaches the counter SV, the PV is automatically reset to 0. In decrement mode, the counter PV starts decrementing from the counter SV. When the counter PV reaches the 0, the PV is automatically reset to the SV.	Read/Write	<ul style="list-style-type: none"> Retained when power is turned ON. Cleared when operation starts. Refreshed when interrupt is generated. Refreshed when INI(880) instruction is executed.
Interrupt Counter 1 Counter PV	A537		Read/Write	
Interrupt Counter 2 Counter PV	A538		Read/Write	
Interrupt Counter 3 Counter PV	A539		Read/Write	

High-speed Counters

Name	Address	Description	Read/Write	Times when data is accessed
High-speed Counter 0 PV	A270 to A271	Contains the PV of high-speed counter 0. A271 contains the leftmost 4 digits and A270 contains the rightmost 4 digits.	Read only	<ul style="list-style-type: none"> Cleared when power is turned ON. Cleared when operation starts. Refreshed each cycle during over-seeing process. Refreshed when PRV(881) instruction is executed for the corresponding counter.
High-speed Counter 1 PV	A272 to A273	Contains the PV of high-speed counter 1. A273 contains the leftmost 4 digits and A272 contains the rightmost 4 digits.	Read only	

Name	Address	Description	Read/Write	Times when data is accessed
High-speed Counter 0 Range 1 Comparison Condition Met Flag	A27400	These flags indicate whether the PV is within the specified ranges when high-speed counter 0 is being operated in range-comparison mode. 0: PV not in range 1: PV in range	Read only	<ul style="list-style-type: none"> • Cleared when power is turned ON. • Cleared when operation starts. • Refreshed each cycle during over-seeing process. • Refreshed when PRV(881) instruction is executed for the corresponding counter.
High-speed Counter 0 Range 2 Comparison Condition Met Flag	A27401		Read only	
High-speed Counter 0 Range 3 Comparison Condition Met Flag	A27402		Read only	
High-speed Counter 0 Range 4 Comparison Condition Met Flag	A27403		Read only	
High-speed Counter 0 Range 5 Comparison Condition Met Flag	A27404		Read only	
High-speed Counter 0 Range 6 Comparison Condition Met Flag	A27405		Read only	
High-speed Counter 0 Range 7 Comparison Condition Met Flag	A27406		Read only	
High-speed Counter 0 Range 8 Comparison Condition Met Flag	A27407		Read only	
High-speed Counter 0 Comparison In-progress Flag	A27408	This flag indicates whether a comparison operation is being executed for high-speed counter 0. 0: Stopped. 1: Being executed.	Read only	<ul style="list-style-type: none"> • Cleared when power is turned ON. • Cleared when operation starts. • Refreshed when comparison operation starts or stops.
High-speed Counter 0 Overflow/Underflow Flag	A27409	This flag indicates when an overflow or underflow has occurred in the high-speed counter 0 PV. (Used only when the counting mode is set to Linear Mode.) 0: Normal 1: Overflow or underflow	Read only	<ul style="list-style-type: none"> • Cleared when power is turned ON. • Cleared when operation starts. • Cleared when the PV is changed. • Refreshed when an overflow or underflow occurs.

Name	Address	Description	Read/Write	Times when data is accessed
High-speed Counter 0 Count Direction	A27410	This flag indicates whether the high-speed counter is currently being incremented or decremented. The counter PV for the current cycle is compared with the PC in last cycle to determine the direction. 0: Decrementing 1: Incrementing	Read only	<ul style="list-style-type: none"> Setting used for high-speed counter, valid during counter operation.
High-speed Counter 1 Range 1 Comparison Condition Met Flag	A27500	These flags indicate whether the PV is within the specified ranges when high-speed counter 1 is being operated in range-comparison mode. 0: PV not in range 1: PV in range	Read only	<ul style="list-style-type: none"> Cleared when power is turned ON. Cleared when operation starts. Refreshed each cycle during over-seeing process. Refreshed when PRV(881) instruction is executed for the corresponding counter.
High-speed Counter 1 Range 2 Comparison Condition Met Flag	A27501		Read only	
High-speed Counter 1 Range 3 Comparison Condition Met Flag	A27502		Read only	
High-speed Counter 1 Range 4 Comparison Condition Met Flag	A27503		Read only	
High-speed Counter 1 Range 5 Comparison Condition Met Flag	A27504		Read only	
High-speed Counter 1 Range 6 Comparison Condition Met Flag	A27505		Read only	
High-speed Counter 1 Range 7 Comparison Condition Met Flag	A27506		Read only	
High-speed Counter 1 Range 8 Comparison Condition Met Flag	A27507		Read only	
High-speed Counter 1 Comparison In-progress Flag	A27508		This flag indicates whether a comparison operation is being executed for high-speed counter 1. 0: Stopped. 1: Being executed.	

Name	Address	Description	Read/Write	Times when data is accessed
High-speed Counter 1 Overflow/Underflow Flag	A27509	This flag indicates when an overflow or underflow has occurred in the high-speed counter 1 PV. (Used only when the counting mode is set to Linear Mode.) 0: Normal 1: Overflow or underflow	Read only	<ul style="list-style-type: none"> Cleared when power is turned ON. Cleared when operation starts. Cleared when the PV is changed. Refreshed when an overflow or underflow occurs.
High-speed Counter 1 Count Direction	A27510	This flag indicates whether the high-speed counter is currently being incremented or decremented. The counter PV for the current cycle is compared with the PC in last cycle to determine the direction. 0: Decrementing 1: Incrementing	Read only	<ul style="list-style-type: none"> Setting used for high-speed counter, valid during counter operation.
High-speed Counter 0 Reset Bit	A53100	When the reset method is set to Phase-Z signal + Software reset, the corresponding high-speed counter's PV will be reset if the phase-Z signal is received while this bit is ON. When the reset method is set to Software reset, the corresponding high-speed counter's PV will be reset in the cycle when this bit goes from OFF to ON.	Read/write	<ul style="list-style-type: none"> Cleared when power is turned ON.
High-speed Counter 1 Reset Bit	A53101		Read/write	
High-speed Counter 0 Gate Bit	A53108	When a counter's Gate Bit is ON, the counter's PV will not be changed even if pulse inputs are received for the counter.	Read/write	<ul style="list-style-type: none"> Cleared when power is turned ON.
High-speed Counter 1 Gate Bit	A53109	When the bit is turned OFF again, counting will restart and the high-speed counter's PV will be refreshed. When the reset method is set to Phase-Z signal + Software reset, the Gate Bit is disabled while the corresponding Reset Bit (A53100 or A53101) is ON.	Read/write	

4-3-2 Auxiliary Area Flags and Bits for Built-in Outputs

The following tables show the Auxiliary Area words and bits that are related to the CJ1M CPU Unit's built-in outputs. These allocations apply to CPU Units equipped with the built-in I/O functions only.

Name	Address	Description	Read/Write	Times when data is accessed
Pulse Output 0 PV	A276 to A277	Contain the number of pulses output from the corresponding pulse output port.	Read only	<ul style="list-style-type: none"> • Cleared when power is turned ON. • Cleared when operation starts. • Refreshed each cycle during over-see process. • Refreshed when the INI(880) instruction is executed for the corresponding pulse output.
Pulse Output 1 PV	A278 to A279	<p>PV range: 80000000 to 7FFFFFFF hex (-2,147,483,648 to 2,147,483,647)</p> <p>When pulses are being output in the CW direction, the PV is incremented by 1 for each pulse. When pulses are being output in the CCW direction, the PV is decremented by 1 for each pulse.</p> <p>PV after overflow: 7FFFFFFF hex PV after underflow: 80000000 hex</p> <p>A277 contains the leftmost 4 digits and A276 contains the rightmost 4 digits of the pulse output 0 PV. A279 contains the leftmost 4 digits and A278 contains the rightmost 4 digits of the pulse output 1 PV.</p> <p>Note If the coordinate system is relative coordinates (undefined origin), the PV will be cleared to 0 when a pulse output starts, i.e. when a pulse output instruction (SPED(885), ACC(888), or PLS2(887)) is executed.</p>		
Pulse Output 0 Accel/Decel Flag	A28000	<p>This flag will be ON when pulses are being output from pulse output 0 according to an ACC(888) or PLS2(887) instruction and the output frequency is being changed in steps (accelerating or decelerating).</p> <p>0: Constant speed 1: Accelerating or decelerating</p>	Read only	<ul style="list-style-type: none"> • Cleared when power is turned ON. • Cleared when operation starts or stops. • Refreshed each cycle during over-see process.
Pulse Output 0 Overflow/Underflow Flag	A28001	<p>This flag indicates when an overflow or underflow has occurred in the pulse output 0 PV.</p> <p>0: Normal 1: Overflow or underflow</p>	Read only	<ul style="list-style-type: none"> • Cleared when power is turned ON. • Cleared when operation starts. • Cleared when the PV is changed by the INI(880) instruction. • Refreshed when an overflow or underflow occurs.
Pulse Output 0 Output Amount Set Flag	A28002	<p>ON when the number of output pulses for pulse output 0 has been set with the PULS instruction.</p> <p>0: No setting 1: Setting made</p>	Read only	<ul style="list-style-type: none"> • Cleared when power is turned ON. • Cleared when operation starts or stops. • Refreshed when the PULS instruction is executed. • Refreshed when pulse output stops.

Name	Address	Description	Read/Write	Times when data is accessed
Pulse Output 0 Output Completed Flag	A28003	ON when the number of output pulses set with the PULS/PLS2 instruction has been output through pulse output 0. 0: Output not completed. 1: Output completed.	Read only	<ul style="list-style-type: none"> • Cleared when power is turned ON. • Cleared when operation starts or stops. • Refreshed at the start or completion of pulse output in independent mode.
Pulse Output 0 Output In-progress Flag	A28004	ON when pulses are being output from pulse output 0. 0: Stopped 1: Outputting pulses.	Read only	<ul style="list-style-type: none"> • Cleared when power is turned ON. • Cleared when operation starts or stops. • Refreshed when pulse output starts or stops.
Pulse Output 0 No-origin Flag	A28005	ON when the origin has not been determined for pulse output 0 and goes OFF when the origin has been determined. 0: Origin established. 1: Origin not established.	Read only	<ul style="list-style-type: none"> • Turned ON when power is turned ON. • Turned ON when operation starts. • Refreshed when pulse output starts or stops. • Refreshed each cycle during the overseeing processes.
Pulse Output 0 At-origin Flag	A28006	ON when the pulse output PV matches the origin (0). 0: Not stopped at origin. 1: Stopped at origin.	Read only	<ul style="list-style-type: none"> • Cleared when power is turned ON. • Refreshed each cycle during the overseeing processes.
Pulse Output 0 Output Stopped Error Flag	A28007	ON when an error occurred while outputting pulses in the pulse output 0 origin search function. The Pulse Output 0 Output Stop Error code will be written to A444. 0: No error 1: Stop error occurred.	Read only	<ul style="list-style-type: none"> • Cleared when power is turned ON. • Refreshed when origin search starts. • Refreshed when a pulse output stop error occurs. • When the Pulse Output 0/1 Limit Input Signal Operation parameter in the PLC Setup is set to <i>Always</i>: • Turned ON when pulse output is stopped for the limit input. • Cleared when the limit input is disabled, pulse output is stopped, and the error code has been stored.

Name	Address	Description	Read/Write	Times when data is accessed
Pulse Output 1 Accel/Decel Flag	A28100	This flag will be ON when pulses are being output from pulse output 1 according to an ACC(888) or PLS2(887) instruction and the output frequency is being changed in steps (accelerating or decelerating). 0: Constant speed 1: Accelerating or decelerating	Read only	<ul style="list-style-type: none"> • Cleared when power is turned ON. • Cleared when operation starts or stops. • Refreshed each cycle during oversee process.
Pulse Output 1 Overflow/Underflow Flag	A28101	This flag indicates when an overflow or underflow has occurred in the pulse output 1 PV. 0: Normal 1: Overflow or underflow	Read only	<ul style="list-style-type: none"> • Cleared when power is turned ON. • Cleared when operation starts. • Cleared when the PV is changed by the INI(880) instruction. • Refreshed when an overflow or underflow occurs.
Pulse Output 1 Output Amount Set Flag	A28102	ON when the number of output pulses for pulse output 1 has been set with the PULS instruction. 0: No setting 1: Setting made	Read only	<ul style="list-style-type: none"> • Cleared when power is turned ON. • Cleared when operation starts or stops. • Refreshed when the PULS instruction is executed. • Refreshed when pulse output stops.
Pulse Output 1 Output Completed Flag	A28103	ON when the number of output pulses set with the PULS/PLS2 instruction has been output through pulse output 1. 0: Output not completed. 1: Output completed.	Read only	<ul style="list-style-type: none"> • Cleared when power is turned ON. • Cleared when operation starts or stops. • Refreshed at the start or completion of pulse output in independent mode.
Pulse Output 1 Output In-progress Flag	A28104	ON when pulses are being output from pulse output 1. 0: Stopped 1: Outputting pulses.	Read only	<ul style="list-style-type: none"> • Cleared when power is turned ON. • Cleared when operation starts or stops. • Refreshed when pulse output starts or stops.
Pulse Output 1 No-origin Flag	A28105	ON when the origin has not been determined for pulse output 1 and goes OFF when the origin has been determined. 0: Origin established. 1: Origin not established.	Read only	<ul style="list-style-type: none"> • Turned ON when power is turned ON. • Turned ON when operation starts. • Refreshed when pulse output starts or stops. • Refreshed each cycle during the overseeing processes.

Name	Address	Description	Read/Write	Times when data is accessed
Pulse Output 1 At-origin Flag	A28106	ON when the pulse output PV matches the origin (0). 0: Not stopped at origin. 1: Stopped at origin.	Read only	<ul style="list-style-type: none"> Cleared when power is turned ON. Refreshed each cycle during the overseeing processes.
Pulse Output 1 Output Stopped Error Flag	A28107	ON when an error occurred while outputting pulses in the pulse output 1 origin search function. The Pulse Output 1 Output Stop Error code will be written to A445. 0: No error 1: Stop error occurred.	Read only	<ul style="list-style-type: none"> Cleared when power is turned ON. Refreshed when origin search starts. Refreshed when a pulse output stop error occurs. When the Pulse Output 0/1 Limit Input Signal Operation parameter in the PLC Setup is set to <i>Always</i>: Turned ON when pulse output is stopped for the limit input. Cleared when the limit input is disabled, pulse output is stopped, and the error code has been stored.
PWM(891) Output 0 Output In-progress Flag	A28300	ON when pulses are being output from PWM(891) output 0. 0: Stopped 1: Outputting pulses.	Read only	<ul style="list-style-type: none"> Cleared when power is turned ON. Cleared when operation starts or stops. Refreshed when pulse output starts or stops.
PWM(891) Output 1 Output In-progress Flag	A28308	ON when pulses are being output from PWM(891) output 1. 0: Stopped 1: Outputting pulses.	Read only	
Pulse Output 0 Stop Error Code	A444	When a pulse output stop error occurred with pulse output 0, the corresponding error code is written to this word.	Read only	<ul style="list-style-type: none"> Cleared when power is turned ON. Refreshed when origin search starts. Refreshed when a pulse output stop error occurs.
Pulse Output 1 Stop Error Code	A445	When a pulse output stop error occurred with pulse output 1, the corresponding error code is written to this word.	Read only	
Pulse Output 0 Reset Bit	A54000	The pulse output 0 PV (contained in A276 and A277) will be cleared when this bit is turned from OFF to ON.	Read/Write	<ul style="list-style-type: none"> Cleared when power is turned ON.

Name	Address	Description	Read/Write	Times when data is accessed
Pulse Output 0 CW Limit Input Signal Flag	A54008	This is the CW limit input signal for pulse output 0, which is used in the origin search. To use this signal, write the input from the actual sensor as an input condition in the ladder program and output the result to this flag.	Read/Write	Cleared when power is turned ON.
Pulse Output 0 CCW Limit Input Signal Flag	A54009	This is the CCW limit input signal for pulse output 0, which is used in the origin search. To use this signal, write the input from the actual sensor as an input condition in the ladder program and output the result to this flag.	Read/Write	
Pulse Output 1 Reset Bit	A54100	The pulse output 1 PV (contained in A278 and A279) will be cleared when this bit is turned from OFF to ON.	Read/Write	
Pulse Output 1 CW Limit Input Signal Flag	A54108	This is the CW limit input signal for pulse output 1, which is used in the origin search. To use this signal, write the input from the actual sensor as an input condition in the ladder program and output the result to this flag.	Read/Write	
Pulse Output 1 CCW Limit Input Signal Flag	A54109	This is the CCW limit input signal for pulse output 1, which is used in the origin search. To use this signal, write the input from the actual sensor as an input condition in the ladder program and output the result to this flag.	Read/Write	

4-4 Flag Operations during Pulse Output

The flags related to pulse outputs are refreshed at the following times.

- When PULS is executed
- When pulse output operation is started or stopped by SPED, ACC, PLS2, INI, or ORG
- When the Reset Flag is turned ON
- When the operating status of the CPU Unit changes, i.e., when power is turned ON or when operation is started or stopped

Relationship between Flag Changes and Refresh Timing

	PVs	Accel/Decel Flags	Overflow/Underflow	Output Amount Set	Output Completed	Output In Progress	Origin Not Established	Origin Stop
PULS (886)	---	---	---	↑	---	---	---	---
SPED(885)	Changes	---	↑↓	↓	↑↓	↑↓	---	↑↓
ACC(888)	Changes	↑↓	↑↓	↓	↑↓	↑↓	---	↑↓
PLS2(887)	Changes	↑↓	↑↓		↑↓	↑↓	---	↑↓
PWM(891)	---	---	---	---	---	---	---	---
INI(880)	Changes	↓	↓	↓	---	↓	↓	↑↓
ORG (889)	Origin search	Changes	↑↓	↓	---	---	↑↓	↑
	Origin return	Changes	↑↓	---	---	↑↓	↑↓	↑
Operation starts	0	↓	↓	↓	↓	↓	↑	---
Operation stops	---	↓	---	↓	↓	↓	---	---
Reset	Changes	↓	↓	---	---	↓	↑	↓
Power ON	0	↓	↓	↓	↓	↓	↑	↓

	PVs	Accel/ Decel Flags	Overflow/ Underflow	Output Amount Set	Output Com- pleted	Output In Progress	Origin Not Estab- lished	Origin Stop
Stop at limit input with origin held (See note 2.)	Changes	↓	---	---	---	↓	---	---
Stop at limit input with undefined origin (See note 2.)	0 (See note 3.)	↓	↓ (See note 3.)	---	---	↓	↑	---

- Note**
1. ---: No change, ↑ ↓: Both ON and OFF, ↑: ON Only, ↓: OFF Only, 0: Cleared to 0
 2. Determined in the PLC Setup, addresses 268 and 286.
 3. The PV and Overflow/Underflow Flags are cleared when a limit input turns ON and the origin is set to be undefined.

SECTION 5

High-speed Counter/Pulse Output Instructions

This section describes the allocation of words and bits for usage with the built-in I/O and PLC Setup settings related to built-in I/O.

5-1	MODE CONTROL: INI(880)	80
5-2	HIGH-SPEED COUNTER PV READ: PRV(881)	83
5-3	COUNTER FREQUENCY CONVERT: PRV2(883)	90
5-4	REGISTER COMPARISON TABLE: CTBL(882)	93
5-5	SPEED OUTPUT: SPED(885)	98
5-6	SET PULSES: PULS(886)	102
5-7	PULSE OUTPUT: PLS2(887)	104
5-8	ACCELERATION CONTROL: ACC(888)	111
5-9	ORIGIN SEARCH: ORG(889)	118
5-10	PULSE WITH VARIABLE DUTY FACTOR: PWM(891)	122

5-1 MODE CONTROL: INI(880)

Purpose

INI(880) can be used to execute the following operations for built-in I/O of CJ1M CPU Units:

- To start comparison with the high-speed counter comparison table
- To stop comparison with the high-speed counter comparison table
- To change the PV of the high-speed counter.
- To change the PV of interrupt inputs in counter mode.
- To change the PV of the pulse output (origin fixed at 0).
- To stop pulse output.

Ladder Symbol

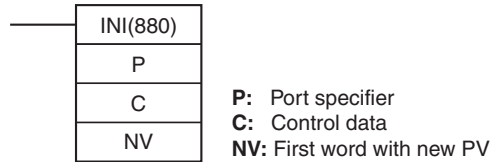

Variations

Variations	Executed Each Cycle for ON Condition	INI(880)
	Executed Once for Upward Differentiation	@INI(880)
	Executed Once for Downward Differentiation	Not supported
Immediate Refreshing Specification		Not supported

Applicable Program Areas

Block program areas	Step program areas	Subroutines	Interrupt tasks
OK	OK	OK	OK

Operands

P: Port Specifier

P specifies the port to which the operation applies.

P	Port
0000 hex	Pulse output 0
0001 hex	Pulse output 1
0010 hex	High-speed counter 0
0011 hex	High-speed counter 1
0100 hex	Interrupt input 0 in counter mode
0101 hex	Interrupt input 1 in counter mode
0102 hex	Interrupt input 2 in counter mode
0103 hex	Interrupt input 3 in counter mode
1000 hex	PWM(891) output 0
1001 hex	PWM(891) output 1

C: Control Data

The function of INI(880) is determined by the control data, C.

C	INI(880) function
0000 hex	Starts comparison.
0001 hex	Stops comparison.
0002 hex	Changes the PV.
0003 hex	Stops pulse output.

NV: First Word with New PV

NV and NV+1 contain the new PV when changing the PV.

If C is 0002 hex (i.e., when changing a PV), NV and NV+1 contain the new PV. Any values in NV and NV+1 are ignored when C is not 0002 hex.

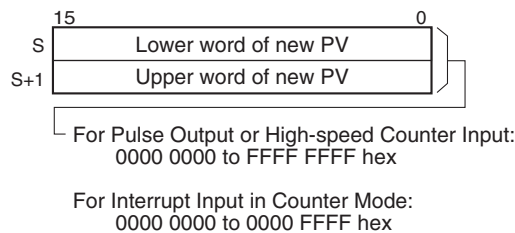

Operand Specifications

Area	P	C	NV
CIO Area	---	---	CIO 0000 to CIO 6142
Work Area	---	---	W000 to W510
Holding Bit Area	---	---	H000 to H510
Auxiliary Bit Area	---	---	A000 to A958
Timer Area	---	---	T0000 to T4094
Counter Area	---	---	C0000 to C4094
DM Area	---	---	D00000 to D32766
EM Area without bank	---	---	---
EM Area with bank	---	---	---
Indirect DM/EM addresses in binary	---	---	@ D00000 to @ D32767
Indirect DM/EM addresses in BCD	---	---	*D00000 to *D32767
Constants	See description of operand.	See description of operand.	---
Data Registers	---	---	---
Index Registers	---	---	---
Indirect addressing using Index Registers	---	---	,IR0 to ,IR15 -2048 to +2047 ,IR0 to -2048 to +2047 ,IR15 DR0 to DR15, IR0 to IR15 ,IR0+(++) to ,IR15+(++) ,-(-)IR0 to ,-(-)IR15

Description

INI(880) performs the operation specified in C for the port specified in P. The possible combinations of operations and ports are shown in the following table.

P: Port specifier	C: Control data			
	0000 hex: Start comparison	0001 hex: Stop comparison	0002 hex: Change PV	0003 hex: Stop pulse output
0000 or 0001 hex: Pulse output	Not allowed.	Not allowed.	OK	OK
0010 or 0011 hex: High-speed counter input	OK	OK	OK	Not allowed.

P: Port specifier	C: Control data			
	0000 hex: Start comparison	0001 hex: Stop comparison	0002 hex: Change PV	0003 hex: Stop pulse output
0100, 0101, 0102, or 0103 hex: Interrupt input in counter mode	Not allowed.	Not allowed.	OK	Not allowed.
1000 or 1001 hex: PWM (891) output	Not allowed.	Not allowed.	Not allowed.	OK

■ **Starting Comparison (C = 0000 hex)**

If C is 0000 hex, INI(880) starts comparison of a high-speed counter's PV to the comparison table registered with CTBL(882).

Note A target value comparison table must be registered in advance with CTBL(882). If INI(880) is executed without registering a table, the Error Flag will turn ON.

■ **Stopping Comparison (C = 0001 hex)**

If C is 0001 hex, INI(880) stops comparison of a high-speed counter's PV to the comparison table registered with CTBL(882).

■ **Changing a PV (C = 0002 hex)**

If C is 0002 hex, INI(880) changes a PV as shown in the following table.

Port and mode			Operation	Setting range
Pulse output (P = 0000 or 0001 hex)			The present value of the pulse output is changed. The new value is specified in NV and NV+1. Note: This instruction can be executed only when pulse output is stopped. An error will occur if it is executed during pulse output.	8000 0000 to 7FFF FFFF hex (-2,147,483,648 to 2,147,483,647)
High-speed counter input (P = 0010 or 0011 hex)	Linear Mode	Differential inputs, increment/decrement pulses, or pulse + direction inputs	The present value of the high-speed counter is changed. The new value is specified in NV and NV+1. Note: An error will occur for the instruction if the specified port is not set for a high-speed counter.	8000 0000 to 7FFF FFFF hex (-2,147,483,648 to 2,147,483,647)
		Increment pulse input		
	Ring Mode			
Interrupt inputs in counter mode (P = 0100, 0101, 0102, or 0103 hex)			The present value of the interrupt input is changed. The new value is specified in NV and NV+1.	0000 0000 to 0000 FFFF hex (0 to 65,535) Note: An error will occur if a value outside this range is specified.

■ **Stopping Pulse Output (P = 1000 or 1001 hex and C = 0003 hex)**

If C is 0003 hex, INI(880) immediately stops pulse output for the specified port. If this instruction is executed when pulse output is already stopped, then the pulse amount setting will be cleared.

Flags

Name	Label	Operation
Error Flag	ER	ON if the specified range for P, C, or NV is exceeded. ON if the combination of P and C is not allowed. ON if a comparison table has not been registered but starting comparison is specified. ON if a new PV is specified for a port that is currently outputting pulses. ON if changing the PV of a high-speed counter is specified for a port that is not specified for a high-speed counter. ON if a value that is out of range is specified as the PV for an interrupt input in counter mode. ON if INI(880) is executed in an interrupt task for a high-speed counter and an interrupt occurs when CTBL(882) is executed. ON if executed for a port not set for an interrupt input in counter mode.

Example

When CIO 000000 turns ON in the following example, SPED(885) starts outputting pulses from pulse output 0 in Continuous Mode at 500 Hz. When CIO 000001 turns ON, pulse output is stopped by INI(880).

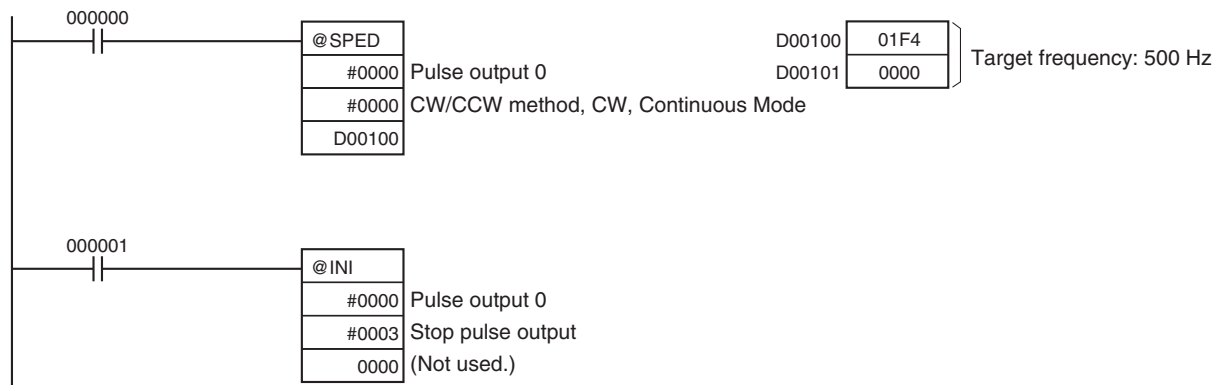

5-2 HIGH-SPEED COUNTER PV READ: PRV(881)

Purpose

PRV(881) reads the following data on the built-in I/O of CJ1M CPU Units.

- PVs: High-speed counter PV, pulse output PV, interrupt input PV in counter mode.
- The following status information.

Status type	Contents
Pulse output status	Pulse Output Status Flag PV Underflow/Overflow Flag Pulse Output Amount Set Flag Pulse Output Completed Flag Pulse Output Flag No-origin Flag At Origin Flag Pulse Output Stopped Error Flag
High-speed counter input status	Comparison In-progress Flag PV Underflow/Overflow Flag
PWM(891) output status	Pulse Output In-progress Flag

- Range comparison results.
- High-speed counter frequency for high-speed counter input 0.
- Pulse output frequency for pulse output 0 or 1 (CJ1M CPU Units with unit version 3.0 or later only).

Ladder Symbol

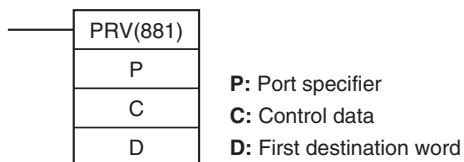

Variations

Variations	Executed Each Cycle for ON Condition	PRV(881)
	Executed Once for Upward Differentiation	@PRV(881)
	Executed Once for Downward Differentiation	Not supported
Immediate Refreshing Specification		Not supported

Applicable Program Areas

Block program areas	Step program areas	Subroutines	Interrupt tasks
OK	OK	OK	OK

Operands

P: Port Specifier

P specifies the port to which the operation applies.

P	Port
0000 hex	Pulse output 0
0001 hex	Pulse output 1
0010 hex	High-speed counter 0
0011 hex	High-speed counter 1
0100 hex	Interrupt input 0 in counter mode
0101 hex	Interrupt input 1 in counter mode
0102 hex	Interrupt input 2 in counter mode
0103 hex	Interrupt input 3 in counter mode
1000 hex	PWM(891) output 0
1001 hex	PWM(891) output 1

C: Control Data

The function of INI(880) is determined by the control data, C.

C	PRV(881) function
0000 hex	Reads the PV.
0001 hex	Reads status.
0002 hex	Reads range comparison results.
00□3 hex	Reads the high-speed counter frequency for high-speed counter input 0.

00□3 hex:

P = 0000 or 0001 hex: Reads the frequency of pulse output 0 or 1.

P = 0010 hex: Reads the frequency of high-speed counter input 0.

C = 0003 hex: Standard operation

C = 0013 hex: 10-ms sampling method for high frequency (supported only by CJ1M CPU Units Ver. 3.0 or later)

C = 0023 hex: 100-ms sampling method for high frequency (supported only by CJ1M CPU Units Ver. 3.0 or later)

C = 0033 hex: 1-s sampling method for high frequency (supported only by CJ1M CPU Units Ver. 3.0 or later)

D: First Destination Word

The PV is output to D or to D and D+1.

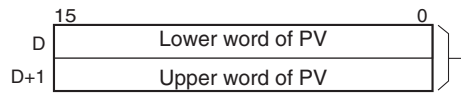

2-word PV
Pulse output PV, high-speed counter input PV,
high-speed counter input frequency for high-speed counter input 0

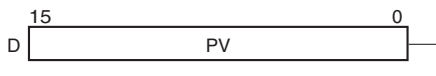

1-word PV
Interrupt input PV in counter mode, status, range comparison results

Operand Specifications

Area	P	C	D
CIO Area	---	---	CIO 0000 to CIO 6142
Work Area	---	---	W000 to W510
Holding Bit Area	---	---	H000 to H510
Auxiliary Bit Area	---	---	A448 to A958
Timer Area	---	---	T0000 to T4094
Counter Area	---	---	C0000 to C4094
DM Area	---	---	D00000 to D32766
EM Area without bank	---	---	---
EM Area with bank	---	---	---
Indirect DM/EM addresses in binary	---	---	@ D00000 to @ D32767
Indirect DM/EM addresses in BCD	---	---	*D00000 to *D32767
Constants	See description of operand.	See description of operand.	---
Data Registers	---	---	---
Index Registers	---	---	---
Indirect addressing using Index Registers	---	---	,IR0 to ,IR15 -2048 to +2047 ,IR0 to -2048 to +2047 ,IR15 DR0 to DR15, IR0 to IR15 ,IR0+(++) to ,IR15+(++) ,-(--)IR0 to ,-(--)IR15

Description PRV(881) reads the data specified in C for the port specified in P. The possible combinations of data and ports are shown in the following table.

P: Port specifier	C2: Control data						
	0000 hex: Read PV	0001 hex: Read status	0002 hex: Read range comparison results	00□3 hex: Read frequency			
				0003 hex: Normal method	0013 hex: 10- ms sampling	0023 hex: 100-ms sampling	0033 hex: 1-s sampling
0000 or 0001 hex: Pulse output	OK	OK	Not allowed.	OK (See note.)	Not allowed.	Not allowed.	Not allowed.
0010 or 0011 hex: High-speed counter input	OK	OK	OK	OK (high-speed counter 0 only)	OK (high-speed counter 0 only) (See note.)	OK (high-speed counter 0 only) (See note.)	OK (high-speed counter 0 only) (See note.)
0100, 0101, 0102, or 0103 hex: Inter- rupt input in counter mode	OK	Not allowed.	Not allowed.	Not allowed.	Not allowed.	Not allowed.	Not allowed.
1000 or 1001 hex: PWM (891) output	Not allowed.	OK	Not allowed.	Not allowed.	Not allowed.	Not allowed.	Not allowed.

Note CJ1M CPU Units with unit version 3.0 or later only.

■ **Reading a PV (C = 0000 hex)**

If C is 0000 hex, PRV(881) reads a PV as shown in the following table.

Port and mode		Operation	Setting range
Pulse output (P = 0000 or 0001 hex)		The present value of the pulse output is stored in D and D+1.	8000 0000 to 7FFF FFFF hex (-2,147,483,648 to 2,147,483,647)
High-speed counter input (P = 0010 or 0011 hex)	Linear Mode	The present value of the high-speed counter is stored in D and D+1.	8000 0000 to 7FFF FFFF hex (-2,147,483,648 to 2,147,483,647)
	Ring Mode		0000 0000 to FFFF FFFF hex (0 to 4,294,967,295)
Interrupt inputs in counter mode (P = 0100, 0101, 0102, or 0103 hex)		The present value of the interrupt input is stored in D.	0000 to FFFF hex (0 to 65,535)

■ **Reading Status (C = 0001 hex)**

If C is 0001 hex, PRV(881) reads status as shown in the following table.

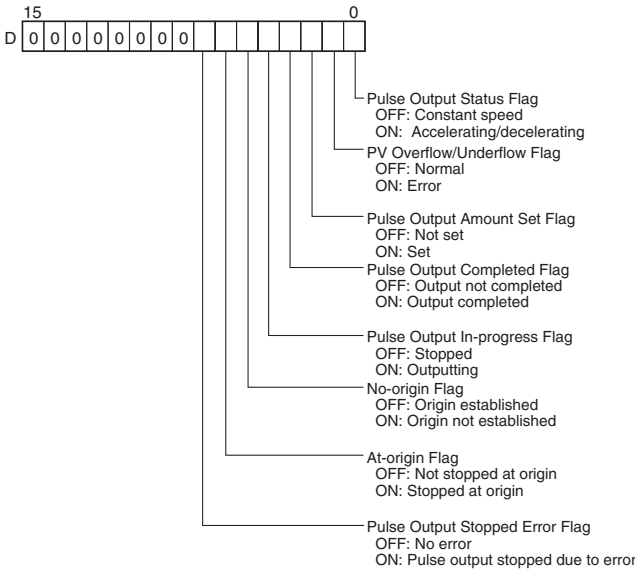
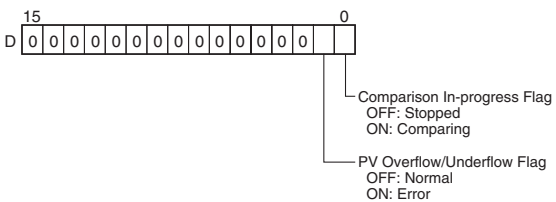
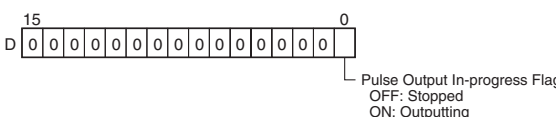
Port and mode	Operation	Results of reading
Pulse output	The pulse output status is stored in D.	
High-speed counter input	The high-speed counter status is stored in D.	
PWM(891) output	The PWM(891) output is stored in D.	

■ **Reading the Results of Range Comparison (C = 0002 hex)**

If C is 0002 hex, PRV(881) reads the results of range comparison and stores it in D as shown in the following diagram.

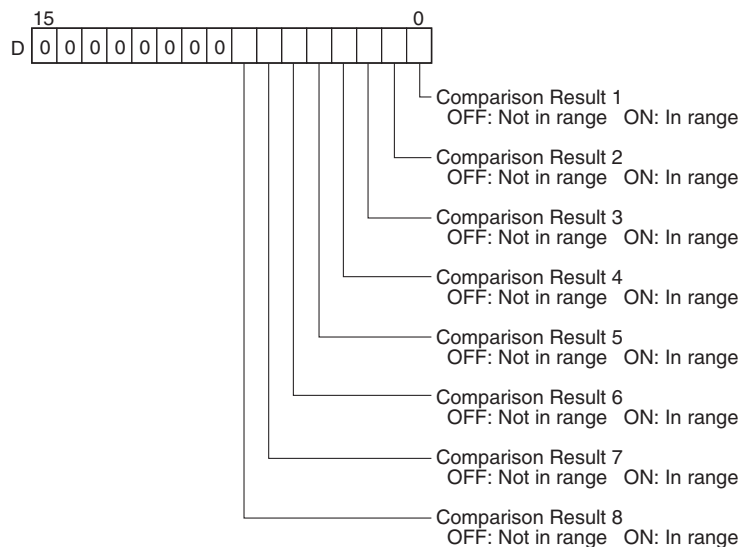

■ **Reading Pulse Output or High-speed Counter Frequency (C = 00□3 hex)**

If C is 00□3 hex, PRV(881) reads the frequency being output from pulse output 0 or 1 or the pulse frequency (Hz) being input to high-speed counter 0 and stores it in D and D+1.

Frequency Ranges

Value of C	Conversion result
0000 or 0001 hex (Reading the frequency of pulse output 0 or 1)	0000 0000 to 0001 86A0 hex (0 to 100,000)
0010 hex (Reading the frequency of high-speed counter input 0)	Counter input method: Any input method other than 4× differential phase mode Result = 00000000 to 000186A0 hex (0 to 100,000) Note If a frequency higher than 100 kHz has been input, the output will remain at the maximum value of 000186A0 hex.
	Counter input method: 4× differential phase mode Result = 00000000 to 00030D40 hex (0 to 200,000) Note If a frequency higher than 200 kHz has been input, the output will remain at the maximum value of 00030D40 hex.

Pulse Frequency Calculation Methods

When the CPU Unit is a CJ1M CPU Unit with unit version 3.0 or later, there are two ways to calculate the frequency of pulses output from pulse output 0 or 1 or pulses input to high-speed counter 0.

1. Standard Calculation Method (Earlier Method)

The count is calculated by counting each pulse regardless of the frequency. At high frequencies, the rising or falling edges of some pulses will be corrupted, resulting in errors (roughly 1% error max. at 100 kHz).

2. High-frequency Calculation Method

In this case, the counting method is switched at high and low frequencies.

• High-frequency counting

At high frequencies (above 1 kHz), the function counts the number of pulses within a fixed interval (the sampling time) and calculates the frequency from that count. One of the following three sampling times can be selected by setting the third digit of C.

Sampling time	Value of C	Description
10 ms	0013 hex	Counts the number of pulses every 10 ms. The error is 10% max. at 1 kHz.
100 ms	0023 hex	Counts the number of pulses every 100 ms. The error is 1% max. at 1 kHz.
1 s	0033 hex	Counts the number of pulses every 1 s. The error is 0.1% max. at 1 kHz.

• Low-frequency counting

At frequencies below 1 kHz, the Standard Calculation Method is used, regardless of the sampling time setting.

Variations

Variations	Executed Each Cycle for ON Condition	PRV(881)
	Executed Once for Upward Differentiation	@PRV(881)
	Executed Once for Downward Differentiation	Not supported
Immediate Refreshing Specification		Not supported

Applicable Program Areas

Block program areas	Step program areas	Subroutines	Interrupt tasks
OK	OK	OK	OK

Flags

Name	Label	Operation
Error Flag	ER	ON if the specified range for P or C is exceeded. ON if the combination of P and C is not allowed. ON if reading range comparison results is specified even though range comparison is not being executed. ON if reading the output frequency is specified for anything except for high-speed counter 0. ON if specified for a port not set for a high-speed counter. ON if executed for a port not set for an interrupt input in counter mode.

Note If the counter is reset when P is set to 0010 hex to specify high-speed counter input 0 and C is set to 0013, 0023, or 0033 hex to specify reading the high-speed counter frequency, the data that is read will be unstable during the sampling time.

Examples

■ **Example 1**

When CIO 000000 turns ON in the following programming example, CTBL(882) registers a range comparison table for high-speed counter 0 and starts comparison. When CIO 000001 turns ON, PRV(881) reads the range comparison results at that time and stores them in CIO 0100.

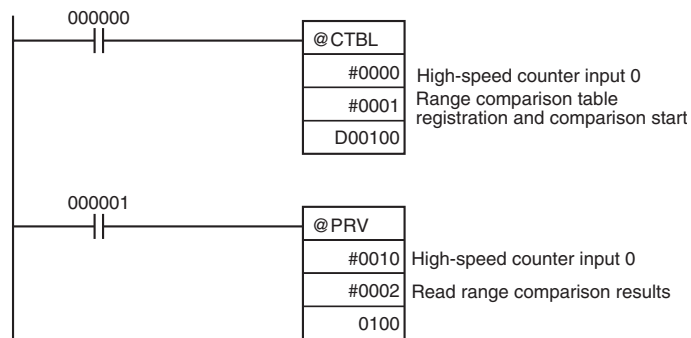

■ **Example 2**

When CIO 000100 turns ON in the following programming example, PRV(881) reads the frequency of the pulse being input to high-speed counter 0 at that time and stores it as a hexadecimal value in D00200 and D00201.

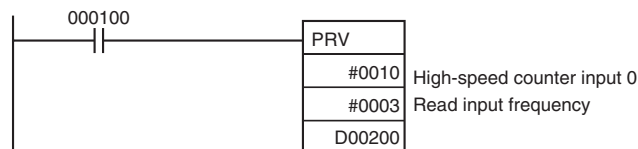

5-3 COUNTER FREQUENCY CONVERT: PRV2(883)

Purpose

PRV2(883) reads the pulse frequency input from a high-speed counter and either converts the frequency to a rotational speed or converts the counter PV to the total number of revolutions. The result is output to the destination words as 8-digit hexadecimal. Pulses can be input from high-speed counter 0 only. This instruction is supported by the CJ1M CPU Units Ver. 2.0 or later only.

Ladder Symbol

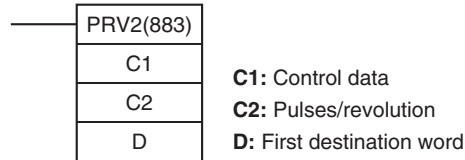

Variations

Variations	Executed Each Cycle for ON Condition	PRV2(883)
	Executed Once for Upward Differentiation	@PRV2(883)
	Executed Once for Downward Differentiation	Not supported
Immediate Refreshing Specification		Not supported

Applicable Program Areas

Block program areas	Step program areas	Subroutines	Interrupt tasks
OK	OK	OK	OK

Operands

C1: Control Data 1

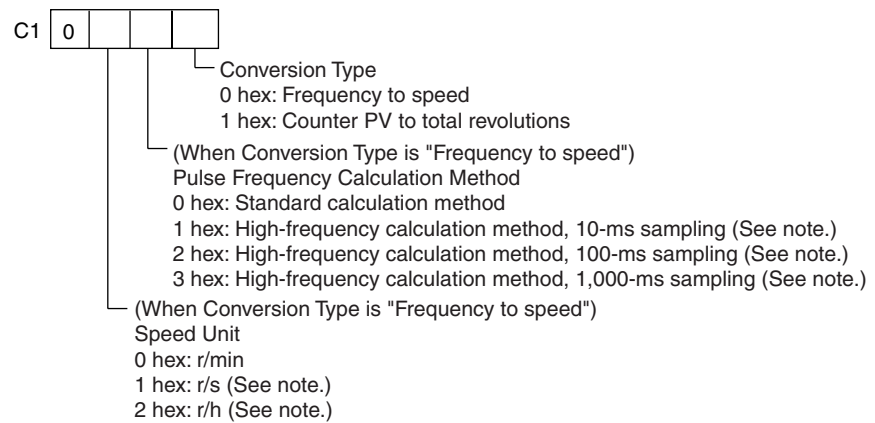

C2: Control Data 2 (Pulses/Revolution)

Specifies the number of pulses per revolution (0001 to FFFF hex).

D: First Destination Word

The PV is output to D or to D and D+1.

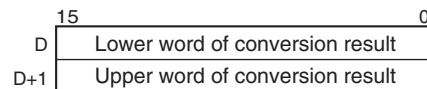

Operand Specifications

Area	C1	C2	D
CIO Area	---	CIO 0000 to CIO 6143	CIO 0000 to CIO 6142
Work Area	---	W000 to W511	W000 to W510
Holding Bit Area	---	H000 to H511	H000 to H510

Area	C1	C2	D
Auxiliary Bit Area	---	A000 to A959	A448 to A958
Timer Area	---	T0000 to T4095	T0000 to T4094
Counter Area	---	C0000 to C4095	C0000 to C4094
DM Area	---	D00000 to D32767	D00000 to D32766
EM Area without bank	---	---	---
EM Area with bank	---	---	---
Indirect DM/EM addresses in binary	---	@ D00000 to @ D32767	@ D00000 to @ D32767
Indirect DM/EM addresses in BCD	---	*D00000 to *D32767	*D00000 to *D32767
Constants	See description of operand.	---	---
Data Registers	---	DR00 to DR15	---
Index Registers	---	---	---
Indirect addressing using Index Registers	---	,IR0 to ,IR15 -2048 to +2047 ,IR0 to -2048 to +2047 ,IR15 DR0 to DR15, IR0 to IR15 ,IR0+(++) to ,IR15+(++) ,-(-)IR0 to ,-(-)IR15	

Description

PRV2(883) converts the pulse frequency input from high-speed counter 0, according to the conversion method specified in C1 and the pulses/revolution coefficient specified in C2, and outputs the result to D and D+1.

Select one of the following conversion methods by setting C1 to 0000 hex or 0001 hex.

Converting Frequency to Rotation Speed (C1 = 0□*0 hex)

The second digit of C1 (□) specifies the units and the third digit (*) specifies the frequency calculation method.

1. Rotation Speed Units

- Rotation Speed Units = r/min

When the second digit of C1 (□) is 0, PRV2(883) calculates the rotation speed in r/min from the frequency data and pulses/revolution setting.

$$\text{Rotation speed (r/min)} = (\text{Frequency} \div \text{Pulses/revolution}) \times 60$$

- Rotation Speed Units = r/s (CJM1 CPU Unit Ver. 3.0 or later only)

When the second digit of C1 (□) is 1, PRV2(883) calculates the rotation speed in r/s from the frequency data and pulses/revolution setting.

$$\text{Rotation speed (r/s)} = \text{Frequency} \div \text{Pulses/revolution}$$

- Rotation Speed Units = r/h (CJM1 CPU Unit Ver. 3.0 or later only)

When the second digit of C1 (□) is 2, PRV2(883) calculates the rotation speed in r/h from the frequency data and pulses/revolution setting.

$$\text{Rotation speed (r/h)} = (\text{Frequency} \div \text{Pulses/revolution}) \times 60 \times 60$$

Range of Conversion Results

- Counter input method: Any method besides 4× differential phase mode
Conversion result = 00000000 to 000186A0 hex (0 to 100,000)
(If a frequency higher than 100 kHz has been input, the output will remain at the maximum value of 000186A0 hex.)

- Counter input method: 4× differential phase mode
Conversion result = 00000000 to 00030D40 hex (0 to 200,000)
(If a frequency higher than 200 kHz has been input, the output will remain at the maximum value of 00030D40 hex.)

2. Frequency Calculation Method

When the CPU Unit is a CJ1M CPU Unit with version number 3.0 or later, there are two ways to calculate the frequency of pulses input to high-speed counter 0.

a) Standard Calculation Method (Earlier Method)

When C1 = 0□00, the count is calculated by counting each pulse regardless of the frequency. At high frequencies, the rising or falling edges of some pulses will be corrupted, resulting in errors (about 1% error max. at 100 kHz).

b) High-frequency Calculation Method

In this case, the counting method is switched at high and low frequencies. (Supported by CJM1 CPU Unit Ver. 3.0 or later only)

- High-frequency counting

At high frequencies (above 1 kHz), the function counts the number of pulses within a fixed interval (the sampling time) and calculates the frequency from that count. One of the following three sampling times can be selected by the third digit of C1.

Sampling time	Value of C1	Description
10 ms	0□10 hex	Counts the number of pulses every 10 ms. The error is 10% max. at 1 kHz.
100 ms	0□20 hex	Counts the number of pulses every 100 ms. The error is 1% max. at 1 kHz.
1 s	0□30 hex	Counts the number of pulses every 1 s. The error is 0.1% max. at 1 kHz.

- Low-frequency counting

At frequencies below 1 kHz, the Standard Calculation Method is used, regardless of the sampling time setting.

Converting Counter PV to Total Number of Revolutions (C1 = 0001 hex)

If C1 is 0001 hex, PRV2(883) calculates the cumulative number of revolutions from the counter PV and pulses/revolution setting.

Conversion result = Counter PV ÷ Pulses/revolution

Flags

Name	Label	Operation
Error Flag	ER	ON if high-speed counter 0 is disabled in the settings. ON if C1 is not in a specified value (0000 or 0001). ON if the pulses/revolution setting in C2 is 0000.

Note If the counter is reset when C1 is set to convert from the frequency to a speed with a high-frequency calculation method, the data that is read will be unstable during the sampling time.

Examples

■ **Example 1**

When CIO 000100 is ON in the following programming example, PRV2(883) reads the present pulse frequency at high-speed counter 0, converts that value to a rotational speed (r/min), and outputs the hexadecimal result to D00201 and D00200.

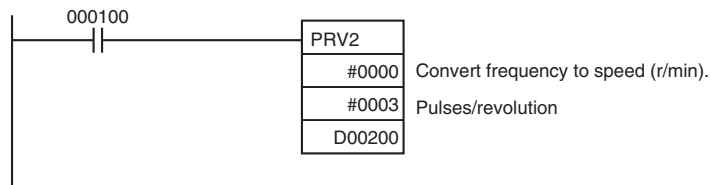

■ **Example 2**

When CIO 000100 is ON in the following programming example, PRV2(883) reads the counter PV, converts that value to number of revolutions, and outputs the hexadecimal result to D00301 and D00300.

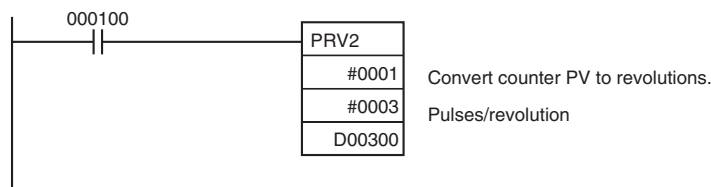

5-4 REGISTER COMPARISON TABLE: CTBL(882)

Purpose

CTBL(882) is used to register a comparison table and perform comparisons for a high-speed counter PV. Either target value or range comparisons are possible. An interrupt task is executed when a specified condition is met.

This instruction is supported by the CJ1M-CPU21/CPU22/CPU23 CPU Units only.

Ladder Symbol

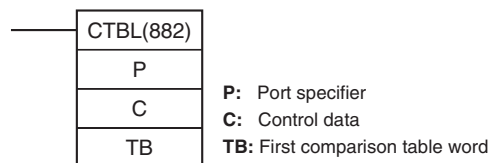

Variations

Variations	Executed Each Cycle for ON Condition	CTBL(882)
	Executed Once for Upward Differentiation	@CTBL(882)
	Executed Once for Downward Differentiation	Not supported
Immediate Refreshing Specification		Not supported

Applicable Program Areas

Block program areas	Step program areas	Subroutines	Interrupt tasks
OK	OK	OK	OK

Operands

P: Port Specifier

P specifies the port for which pulses are to be counted as shown in the following table.

P	Port
0000 hex	High-speed counter 0
0001 hex	High-speed counter 1

C: Control Data

The function of CTBL(882) is determined by the control data, C, as shown in the following table.

C	CTBL(882) function
0000 hex	Registers a target value comparison table and starts comparison.
0001 hex	Registers a range comparison table and performs one comparison.
0002 hex	Registers a target value comparison table. Comparison is started with INI(880).
0003 hex	Registers a range comparison table. Comparison is started with INI(880).

TB: First Table Comparison Word

TB is the first word of the comparison table. The structure of the comparison table depends on the type of comparison being performed.

For target value comparison, the length of the comparison table is determined by the number of target values specified in TB. The table can be between 4 and 145 words long, as shown below.

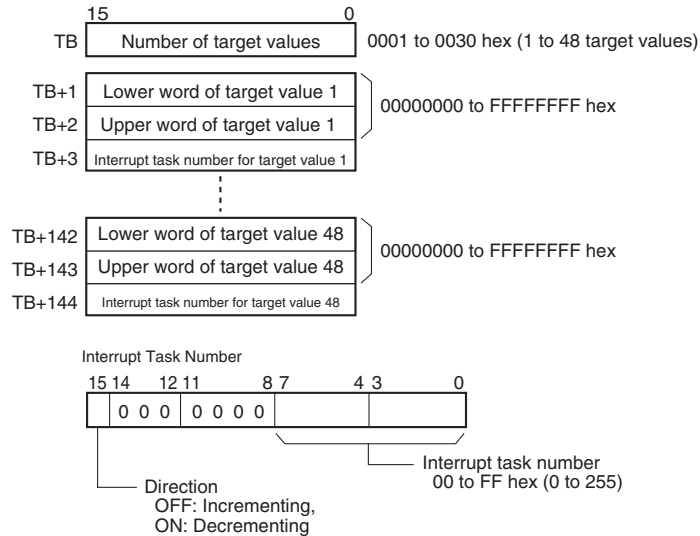

For range comparison, the comparison table always contains eight ranges. The table is 40 words long, as shown below. If it is not necessary to set eight ranges, set the interrupt task number to FFFF hex for all unused ranges.

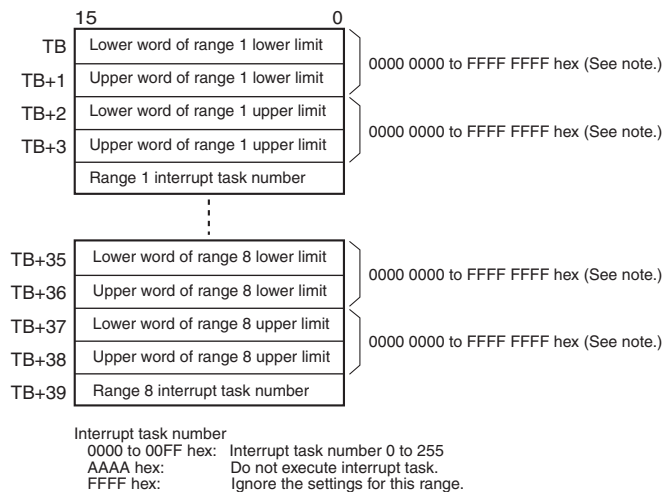

Note Always set the upper limit greater than or equal to the lower limit for any one range.

Operand Specifications

Area	P	C	TB
CIO Area	---	---	CIO 0000 to CIO 6143
Work Area	---	---	W000 to W511
Holding Bit Area	---	---	H000 to H511
Auxiliary Bit Area	---	---	A448 to A959
Timer Area	---	---	T0000 to T4095
Counter Area	---	---	C0000 to C4095
DM Area	---	---	D00000 to D32767
EM Area without bank	---	---	---
EM Area with bank	---	---	---
Indirect DM/EM addresses in binary	---	---	@ D00000 to @ D32767
Indirect DM/EM addresses in BCD	---	---	*D00000 to *D32767
Constants	See description of operand.	See description of operand.	---
Data Registers	---	---	---
Index Registers	---	---	---
Indirect addressing using Index Registers	---	---	,IR0 to ,IR15 -2048 to +2047 ,IR0 to -2048 to +2047 ,IR15 DR0 to DR15, IR0 to IR15 ,IR0+(++) to ,IR15+(++) ,-(--)IR0 to ,-(--)IR15

Description

CTBL(882) registers a comparison table or registers and comparison table and starts comparison for the port specified in P and the method specified in C. Once a comparison table is registered, it is valid until a different table is registered or until the CPU Unit is switched to PROGRAM mode.

Each time CTBL(882) is executed, comparison is started under the specified conditions. When using CTBL(882) to start comparison, it is normally sufficient to use the differentiated version (@CTBL(882)) of the instruction or an execution condition that is turned ON only for one scan.

Note If an interrupt task that has not been registered is specified, a fatal program error will occur the first time an interrupt is generated.

■ **Registering a Comparison Table (C = 0002 or 0003 hex)**

If C is set to 0002 or 0003 hex, a comparison table will be registered, but comparison will not be started. Comparison is started with INI(880).

■ **Registering a Comparison Table and Starting Comparison (C = 0000 or 0001 hex)**

If C is set to 0000 or 0001 hex, a comparison table will be registered, and comparison will be started.

■ **Stopping Comparison**

Comparison is stopped with INI(880). It makes no difference what instruction was used to start comparison.

■ **Target Value Comparison**

The corresponding interrupt task is called and executed when the PV matches a target value.

- The same interrupt task number can be specified for more than one target value.
- The direction can be set to specify whether the target value is valid when the PV is being incremented or decremented. If bit 15 in the word used to specify the interrupt task number for the range is OFF, the PV will be compared with the target value only when the PV is being incremented, and if bit 00 is ON, only when the PV is being decremented.
- The comparison table can contain up to 48 target values, and the number of target values is specified in TB (i.e., the length of the table depends on the number of target values that is specified).
- Comparisons are performed for all target values registered in the table.

- Note**
1. An error will occur if the same target value with the same comparison direction is registered more than once in the same table.
 2. If the high-speed counter is set for incremental pulse mode, an error will occur if decrementing is set in the table as the direction for comparison.
 3. If the count direction changes while the PV equals a target value that was reached in the direction opposite to that set as the comparison direction, the comparison condition for that target value will not be met. Do not set target values at peak and bottom values of the count value.

Range Comparison

The corresponding interrupt task is called and executed when the PV enters a set range.

- The same interrupt task number can be specified for more than one target value.
- The range comparison table contains 8 ranges, each of which is defined by a lower limit and an upper limit. If a range is not to be used, set the interrupt task number to FFFF hex to disable the range.
- The interrupt task is executed only once when the PV enters the range.

- If the PV is within more than one range when the comparison is made, the interrupt task for the range closest to the beginning of the table will be given priority and other interrupt tasks will be executed in following cycles.
- If there is no reason to execute an interrupt task, specify AAAA hex as the interrupt task number. The range comparison results can be read with PRV(881) or using the Range Comparison In-progress Flags.

Note An error will occur if the upper limit is less than the lower limit for any one range.

Flags

Name	Label	Operation
Error Flag	ER	ON if the specified range for P or C is exceeded. ON if the number of target values specified for target value comparison is set to 0. ON if the number of target values specified for target value comparison exceeds 48. ON if the same target value is specified more than once in the same comparison direction for target comparison. ON if the upper value is less than the lower value for any range. ON if the set values for all ranges are disabled during a range comparison. ON if the high-speed counter is set for incremental pulse mode and decrementing is set in the table as the direction for comparison. ON if an instruction is executed when the high-speed counter is set to Ring Mode and the specified value exceeds the maximum ring value. ON if specified for a port not set for a high-speed counter. ON if executed for a different comparison method while comparison is already in progress.

Example

When CIO 000000 turns ON in the following programming example, CTBL(882) registers a target value comparison table and starts comparison for high-speed counter 0. The PV of the high-speed counter is counted incrementally and when it reaches 500, it equals target value 1 and interrupt task 1 is executed. When the PV is incremented to 1000, it equals target value 2 and interrupt task 2 is executed.

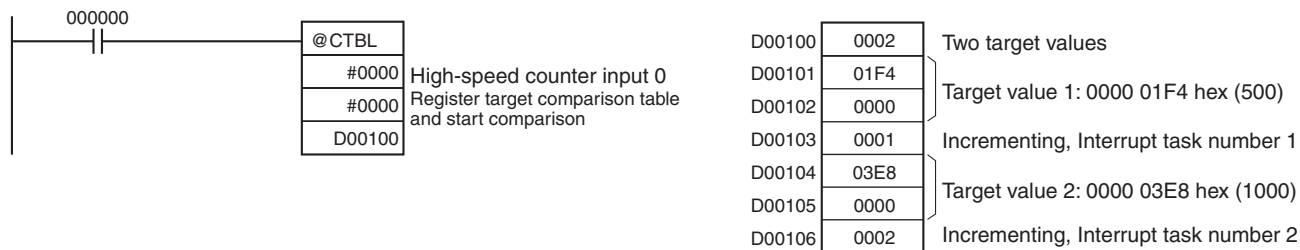

5-5 SPEED OUTPUT: SPED(885)

Purpose

SPED(885) is used to set the output pulse frequency for a specific port and start pulse output without acceleration or deceleration. Either independent mode positioning or continuous mode speed control is possible. For independent mode positioning, the number of pulses is set using PULS(886).

SPED(885) can also be executed during pulse output to change the output frequency, creating stepwise changes in the speed.

This instruction is supported by the CJ1M-CPU21/CPU22/CPU23 CPU Units only.

Ladder Symbol

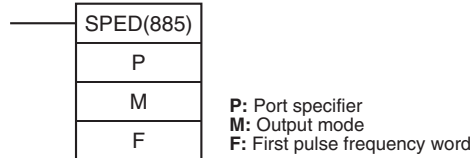

Variations

Variations	Executed Each Cycle for ON Condition	SPED(885)
	Executed Once for Upward Differentiation	@SPED(885)
	Executed Once for Downward Differentiation	Not supported
Immediate Refreshing Specification		Not supported

Applicable Program Areas

Block program areas	Step program areas	Subroutines	Interrupt tasks
OK	OK	OK	OK

Operands

P: Port Specifier

The port specifier specifies the port where the pulses will be output.

P	Port
0000 hex	Pulse output 0
0001 hex	Pulse output 1

M :Output Mode

The value of M determines the output mode.

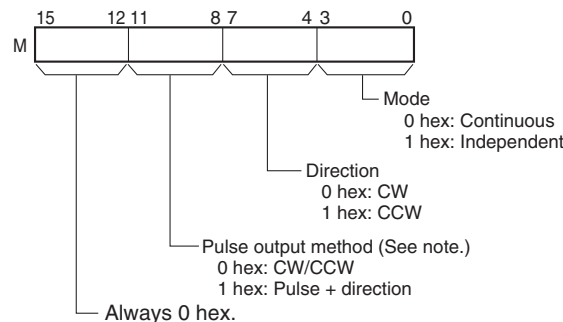

Note: Use the same pulse output method when using both pulse outputs 0 and 1.

F: First Pulse Frequency Word

The value of F and F+1 sets the pulse frequency in Hz.

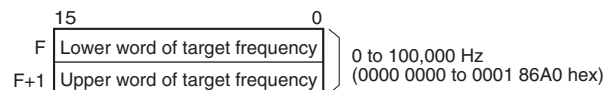

Operand Specifications

Area	P	M	F
CIO Area	---	---	CIO 0000 to CIO 6142
Work Area	---	---	W000 to W510
Holding Bit Area	---	---	H000 to H510
Auxiliary Bit Area	---	---	A000 to A958
Timer Area	---	---	T0000 to T4094
Counter Area	---	---	C0000 to C4094
DM Area	---	---	D00000 to D32766
EM Area without bank	---	---	---
EM Area with bank	---	---	---
Indirect DM/EM addresses in binary	---	---	@ D00000 to @ D32767
Indirect DM/EM addresses in BCD	---	---	*D00000 to *D32767
Constants	See description of operand.	See description of operand.	See description of operand.
Data Registers	---	---	---
Index Registers	---	---	---
Indirect addressing using Index Registers	---	---	,IR0 to ,IR15 -2048 to +2047 ,IR0 to -2048 to +2047 ,IR15 DR0 to DR15, IR0 to IR15 ,IR0+(++) to ,IR15+(++) ,-(-)IR0 to ,-(-)IR15

Description

SPED(885) starts pulse output on the port specified in P using the method specified in M at the frequency specified in F. Pulse output will be started each time SPED(885) is executed. It is thus normally sufficient to use the differentiated version (@SPED(885)) of the instruction or an execution condition that is turned ON only for one scan.

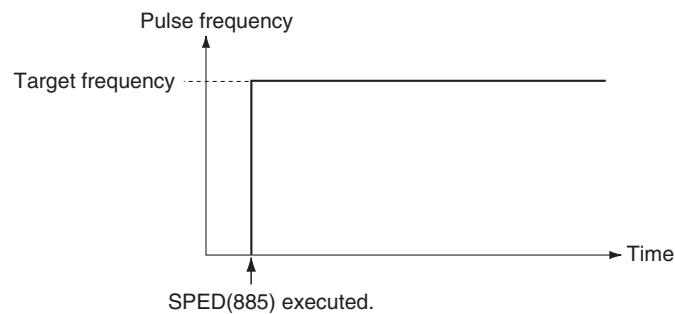

In independent mode, pulse output will stop automatically when the number of pulses set with PULS(886) in advance have been output. In continuous mode, pulse output will continue until stopped from the program.

An error will occur if the mode is changed between independent and continuous mode while pulses are being output.

■ Continuous Mode Speed Control

When continuous mode operation is started, pulse output will be continued until it is stopped from the program.

Note Pulse output will stop immediately if the CPU Unit is changed to PROGRAM mode.

Operation	Purpose	Application	Frequency changes	Description	Procedure/instruction
Starting pulse output	To output with specified speed	Changing the speed (frequency) in one step		Outputs pulses at a specified frequency.	SPED(885) (Continuous)
Changing settings	To change speed in one step	Changing the speed during operation		Changes the frequency (higher or lower) of the pulse output in one step.	SPED(885) (Continuous) ↓ SPED(885) (Continuous)
Stopping pulse output	Stop pulse output	Immediate stop		Stops the pulse output immediately.	SPED(885) (Continuous) ↓ INI(880)
	Stop pulse output	Immediate stop		Stops the pulse output immediately.	SPED(885) (Continuous) ↓ SPED(885) (Continuous, Target frequency of 0 Hz)

■ Independent Mode Positioning

When independent mode operation is started, pulse output will be continued until the specified number of pulses has been output.

- Note**
1. Pulse output will stop immediately if the CPU Unit is changed to PROGRAM mode.
 2. The number of output pulses must be set each time output is restarted.
 3. The number of output pulses must be set in advance with PULS(881). Pulses will not be output for SPED(885) if PULS(881) is not executed first.
 4. The direction set in the SPED(885) operand will be ignored if the number of pulses is set with PULS(881) as an absolute value.

Operation	Purpose	Application	Frequency changes	Description	Procedure/ instruction
Starting pulse output	To output with specified speed	Positioning without acceleration or deceleration	<p>Pulse frequency</p> <p>Specified number of pulses (Specified with PULS(886).)</p> <p>Target frequency</p> <p>Time</p> <p>Execution of SPED(885)</p> <p>Outputs the specified number of pulses and then stops.</p>	Starts outputting pulses at the specified frequency and stops immediately when the specified number of pulses has been output. Note The target position (specified number of pulses) cannot be changed during positioning.	PULS(886) ↓ SPED(885) (Independent)
Changing settings	To change speed in one step	Changing the speed in one step during operation	<p>Pulse frequency</p> <p>Specified number of pulses (Specified with PULS(886).)</p> <p>New target frequency</p> <p>Original target frequency</p> <p>Time</p> <p>Execution of SPED(885) (independent mode)</p> <p>Number of pulses specified with PULS(886) does not change.</p> <p>SPED(885) (independent mode) executed again to change the target frequency. (The target position is not changed.)</p>	SPED(885) can be executed during positioning to change (raise or lower) the pulse output frequency in one step. The target position (specified number of pulses) is not changed.	PULS(886) ↓ SPED(885) (Independent) ↓ SPED(885) (Independent)
Stopping pulse output	To stop pulse output (Number of pulses setting is not preserved.)	Immediate stop	<p>Pulse frequency</p> <p>Present frequency</p> <p>Time</p> <p>Execution of SPED(885)</p> <p>Execution of INI(880)</p>	Stops the pulse output immediately and clears the number of output pulses setting.	PULS(886) ↓ SPED(885) (Independent) ↓ INI(880) ↓ PLS2(887) ↓ INI(880)
	Stop pulse output (Number of pulses setting is not preserved.)	Immediate stop	<p>Pulse frequency</p> <p>Present frequency</p> <p>Time</p> <p>Execution of SPED(885)</p> <p>Execution of SPED(885)</p>	Stops the pulse output immediately and clears the number of output pulses setting.	PULS(886) ↓ SPED(885) (Independent) ↓ SPED(885), (Independent, Target frequency of 0 Hz)

Flags

Name	Label	Operation
Error Flag	ER	<p>ON if the specified range for P, M, or F is exceeded.</p> <p>ON if PLS2(887) or ORG(889) is already being executed to control pulse output for the specified port.</p> <p>ON if SPED(885) or INI(880) is used to change the mode between continuous and independent output during pulse output.</p> <p>ON if SPED(885) is executed in an interrupt task when an instruction controlling pulse output is being executed in a cyclic task.</p> <p>ON if SPEC(885) is executed in independent mode with an absolute number of pulses and the origin has not been established.</p>

Example

When CIO 000000 turns ON in the following programming example, PULS(886) sets the number of output pulses for pulse output 0. An absolute value of 5,000 pulses is set. SPED(885) is executed next to start pulse output using the CW/CCW method in the clockwise direction in independent mode at a target frequency of 500 Hz.

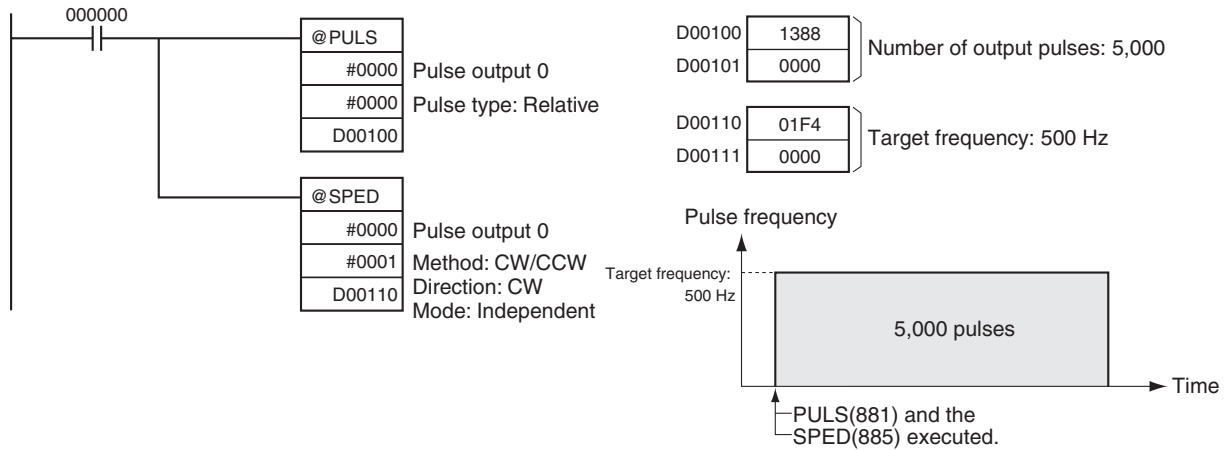

5-6 SET PULSES: PULS(886)

Purpose

PULS(886) is used to set the pulse output amount (number of output pulses) for pulse outputs that are started later in the program using SPED(885) or ACC(888) in independent mode.

This instruction is supported by the CJ1M-CPU21/CPU22/CPU23 CPU Units only.

Ladder Symbol

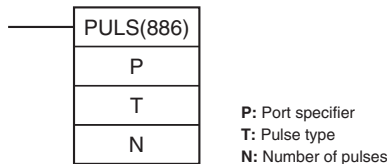

Variations

Variations	Executed Each Cycle for ON Condition	PULS(886)
	Executed Once for Upward Differentiation	@PULS(886)
	Executed Once for Downward Differentiation	Not supported
Immediate Refreshing Specification		Not supported

Applicable Program Areas

Block program areas	Step program areas	Subroutines	Interrupt tasks
OK	OK	OK	OK

Operands

P: Port Specifier

The port specifier indicates the port. The parameters set in D and N will apply to the next SPED(885) or ACC(888) instruction in which the same port output location is specified.

P	Port
0000 hex	Pulse output 0
0001 hex	Pulse output 1

T: Pulse Type

T specifies the type of pulses that are output as follows:

T	Pulse type
0000 hex	Relative
0001 hex	Absolute

N and N+1: Number of Pulses

N and N+1 specify the number of pulses for relative pulse output or the absolute target position for absolute pulse in 8-digit hexadecimal.

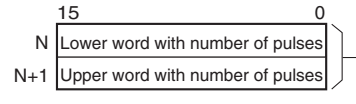

Relative pulse output:
0 to 2,147,483,647 (0000 0000 to 7FFF FFFF hex)

Absolute pulse output:
-2,147,483,648 to 2,147,483,647 (8000 0000 to 7FFF FFFF hex)

The actual number of movement pulses that will be output are as follows:

For relative pulse output, the number of movement pulses = the set number of pulses. For absolute pulse output, the number of movement pulses = the set number of pulses – the PV.

Operand Specifications

Area	P	T	N
CIO Area	---	---	CIO 0000 to CIO 6142
Work Area	---	---	W000 to W510
Holding Bit Area	---	---	H000 to H510
Auxiliary Bit Area	---	---	A448 to A958
Timer Area	---	---	T0000 to T4094
Counter Area	---	---	C0000 to C4094
DM Area	---	---	D00000 to D32766
EM Area without bank	---	---	---
EM Area with bank	---	---	---
Indirect DM/EM addresses in binary	---	---	@ D00000 to @ D32767
Indirect DM/EM addresses in BCD	---	---	*D00000 to *D32767
Constants	See description of operand.	See description of operand.	See description of operand.
Data Registers	---	---	---
Index Registers	---	---	---
Indirect addressing using Index Registers	---	---	,IR0 to ,IR15 -2048 to +2047 ,IR0 to -2048 to +2047 ,IR15 DR0 to DR15, IR0 to IR15 ,IR0+(++) to ,IR15+(++) ,-(--)IR0 to ,-(--)IR15

Description

PULS(886) sets the pulse type and number of pulses specified in T and N for the port specified in P. Actual output of the pulses is started later in the program using SPED(885) or ACC(888) in independent mode.

Flags

Name	Label	Operation
Error Flag	ER	ON if the specified range for P, T, or N is exceeded. ON if PULS(886) is executed for a port that is already outputting pulses. ON if PULS(886) is executed in an interrupt task when an instruction controlling pulse output is being executed in a cyclic task.

Precautions

- An error will occur if PULS(886) is executed when pulses are already being output. Use the differentiated version (@PULS(886)) of the instruction or an execution condition that is turned ON only for one scan to prevent this.
- The calculated number of pulses output for PULS(886) will not change even if INI(880) is used to change the PV of the pulse output.
- The direction set for SPED(885) or ACC(888) will be ignored if the number of pulses is set with PULS(881) as an absolute value.
- It is possible to move outside of the range of the PV of the pulse output amount (-2,147,483,648 to 2,147,483,647).

Example

When CIO 000000 turns ON in the following programming example, PULS(886) sets the number of output pulses for pulse output 0. An absolute value of 5,000 pulses is set. SPED(885) is executed next to start pulse output using the CW/CCW method in the clockwise direction in independent mode at a target frequency of 500 Hz.

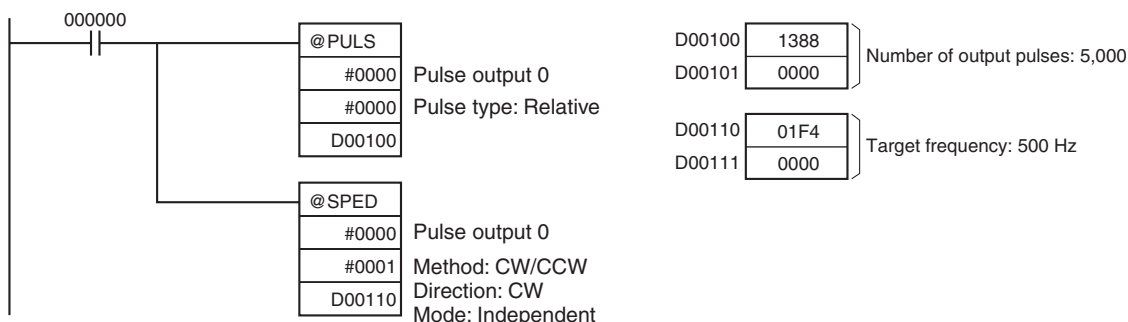

5-7 PULSE OUTPUT: PLS2(887)

Purpose

PLS2(887) outputs a specified number of pulses to the specified port. Pulse output starts at a specified startup frequency, accelerates to the target frequency at a specified acceleration rate, decelerates at the specified deceleration rate, and stops at approximately the same frequency as the startup frequency. Only independent mode positioning is supported.

PLS2(887) can also be executed during pulse output to change the number of output pulses, target frequency, acceleration rate, or deceleration rate. PLS2(887) can thus be used for sloped speed changes with different acceleration and deceleration rates, target position changes, target and speed changes, or direction changes.

This instruction is supported by the CJ1M-CPU21/CPU22/CPU23 CPU Units only.

Ladder Symbol

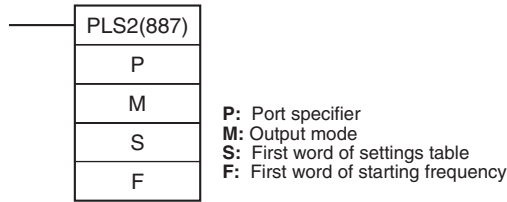

Variations

Variations	Executed Each Cycle for ON Condition	PLS2(887)
	Executed Once for Upward Differentiation	@PLS2(887)
	Executed Once for Downward Differentiation	Not supported
Immediate Refreshing Specification		Not supported

Applicable Program Areas

Block program areas	Step program areas	Subroutines	Interrupt tasks
OK	OK	OK	OK

Operands

P: Port Specifier

The port specifier indicates the port.

P	Port
0000 hex	Pulse output 0
0001 hex	Pulse output 1

M: Output Mode

The content of M specifies the parameters for the pulse output as follows:

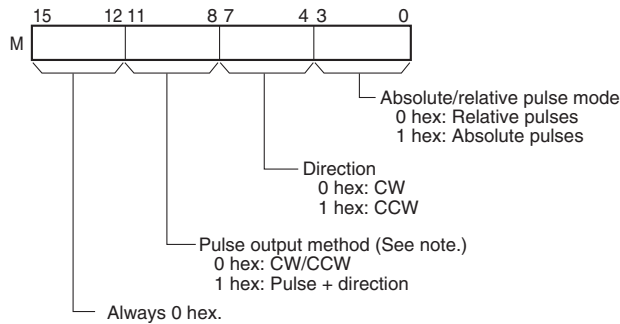

Note: Use the same pulse output method when using both pulse outputs 0 and 1.

S: First Word of Settings Table

The contents of S to S+5 control the pulse output as shown in the following diagrams.

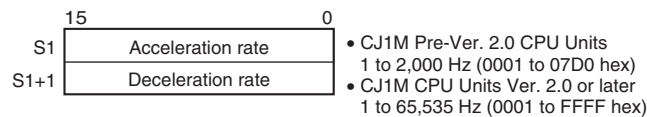

Specify the increase or decrease in the frequency per pulse control period (4 ms).

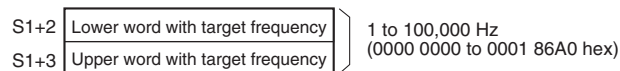

Specify the frequency after acceleration in Hz.

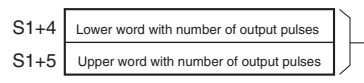

Relative pulse output: 0 to 2,147,483,647
(0000 0000 to 7FFF FFFF hex)

Absolute pulse output: -2,147,483,648 to 2,147,483,647
(8000 0000 to 7FFF FFFF hex)

The actual number of movement pulses that will be output are as follows:

For relative pulse output, the number of movement pulses = the set number of pulses. For absolute pulse output, the number of movement pulses = the set number of pulses – the PV.

F: First Word of Starting Frequency

The starting frequency is given in F and F+1.

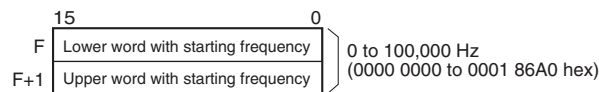

Specify the starting frequency in Hz.

Operand Specifications

Area	P	M	S	F
CIO Area	---	---	CIO 0000 to CIO 6138	CIO 0000 to CIO 6142
Work Area	---	---	W000 to W506	W000 to W510
Holding Bit Area	---	---	H000 to H506	H000 to H510
Auxiliary Bit Area	---	---	A000 to A954	A000 to A958
Timer Area	---	---	T0000 to T4090	T0000 to T4094
Counter Area	---	---	C0000 to C4090	C0000 to C4094
DM Area	---	---	D00000 to D32762	D00000 to D32766
EM Area without bank	---	---	---	---
EM Area with bank	---	---	---	---
Indirect DM/EM addresses in binary	---	---	@ D00000 to @ D32767	@ D00000 to @ D32767
Indirect DM/EM addresses in BCD	---	---	*D00000 to *D32767	*D00000 to *D32767
Constants	See description of operand.	See description of operand.	---	See description of operand.
Data Registers	---	---	---	---

Area	P	M	S	F
Index Registers	---	---	---	---
Indirect addressing using Index Registers	---	---	,IR0 to ,IR15 -2048 to +2047 ,IR0 to -2048 to +2047 ,IR15 DR0 to DR15, IR0 to IR15 ,IR0+(++) to ,IR15+(++) ,-(--)IR0 to ,-(--)IR15	,IR0 to ,IR15 -2048 to +2047 ,IR0 to -2048 to +2047 ,IR15 DR0 to DR15, IR0 to IR15 ,IR0+(++) to ,IR15+(++) ,-(--)IR0 to ,-(--)IR15

Description

PLS2(887) starts pulse output on the port specified in P using the mode specified in M at the start frequency specified in F (1 in diagram). The frequency is increased every pulse control period (4 ms) at the acceleration rate specified in S until the target frequency specified in S is reached (2 in diagram). When the target frequency has been reached, acceleration is stopped and pulse output continues at a constant speed (3 in diagram).

The deceleration point is calculated from the number of output pulses and deceleration rate set in S and when that point is reached, the frequency is decreased every pulse control period (4 ms) at the deceleration rate specified in S until the starting frequency specified in S is reached, at which point pulse output is stopped (4 in diagram).

Pulse output is started each time PLS2(887) is executed. It is thus normally sufficient to use the differentiated version (@PLS2(887)) of the instruction or an execution condition that is turned ON only for one scan.

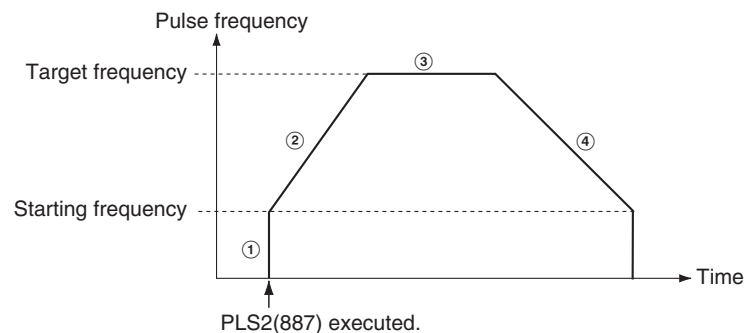

PLS2(887) can be used only for positioning.

With the CJ1M CPU Units, PLS2(887) can be executed during pulse output for ACC(888) in either independent or continuous mode, and during acceleration, constant speed, or deceleration. (See note.) ACC(888) can also be executed during pulse output for PLS2(887) during acceleration, constant speed, or deceleration.

Note Executing PLS2(887) during speed control with ACC(888) (continuous mode) with the same target frequency as ACC(888) can be used to achieve interrupt feeding of a fixed distance. Acceleration will not be performed by PLS2(887) for this application, but if the acceleration rate is set to 0, the Error Flag will turn ON and PLS2(887) will not be executed. Always set the acceleration rate to a value other than 0.

■ Independent Mode Positioning

Note Pulse output will stop immediately if the CPU Unit is changed to PROGRAM mode.

Operation	Purpose	Application	Frequency changes	Description	Procedure/instruction
Starting pulse output	Complex trapezoidal control	Positioning with trapezoidal acceleration and deceleration (Separate rates used for acceleration and deceleration; starting speed) The number of pulses can be changed during positioning.		Accelerates and decelerates at a fixed rates. The pulse output is stopped when the specified number of pulses has been output. (See note.) Note The target position (specified number of pulses) can be changed during positioning.	PLS2(887)
Changing settings	To change speed smoothly (with unequal acceleration and deceleration rates)	Changing the target speed (frequency) during positioning (different acceleration and deceleration rates)		PLS2(887) can be executed during positioning to change the acceleration rate, deceleration rate, and target frequency. Note To prevent the target position from being changed intentionally, the original target position must be specified in absolute coordinates.	PLS2(887) ↓ PLS2(887)
	To change target position	Changing the target position during positioning (multiple start function)		PLS2(887) can be executed during positioning to change the target position (number of pulses), acceleration rate, deceleration rate, and target frequency. Note If a constant speed cannot be maintained after changing the settings, an error will occur and the original operation will continue to the original target position.	PLS2(887) ↓ PLS2(887) ↓ PULS(886) ↓ ACC(888) (Independent) ↓ PLS2(887)

Operation	Purpose	Application	Frequency changes	Description	Procedure/instruction
Changing settings, continued	To change target position and target speed (frequency) during positioning (multiple start function)	Changing the target position and target speed (frequency) during positioning (multiple start function)		<p>PLS2(887) can be executed during positioning to change the target position (number of pulses), acceleration rate, deceleration rate, and target frequency.</p> <p>Note If a constant speed cannot be maintained after changing the settings, an error will occur and the original operation will continue to the original target position.</p>	<p>PLS(886) ↓ ACC(888) (Independent) ↓ PLS2(887)</p>
	Changing the acceleration and deceleration rates during positioning (multiple start function)	Changing the acceleration and deceleration rates during positioning (multiple start function)		<p>PLS2(887) can be executed during positioning (acceleration or deceleration) to change the acceleration rate or deceleration rate.</p>	<p>PLS2(887) ↓ PLS2(887) ↓ PLS(886) ↓ ACC(888) (Independent) ↓ PLS2(887)</p>
	To change direction	Changing the direction during positioning	Changing the direction during positioning		<p>PLS2(887) can be executed during positioning with absolute pulse specification to change to absolute pulses and reverse direction.</p>
Stopping pulse output	Stop pulse output (Number of pulses setting is not preserved.)	Immediate stop		<p>Stops the pulse output immediately and clears the number of output pulses.</p>	<p>PLS2(887) ↓ INI(880)</p>
	Stop pulse output smoothly. (Number of pulses setting is not preserved.)	Decelerate to a stop		<p>Decelerates the pulse output to a stop.</p>	<p>PLS2(887) ↓ ACC(888) (Independent, target frequency of 0 Hz)</p>

Note Triangular Control

If the specified number of pulses is less than the number required to reach the target frequency and return to zero, the function will automatically reduce the acceleration/deceleration time and perform triangular control (acceleration and deceleration only.) An error will not occur.

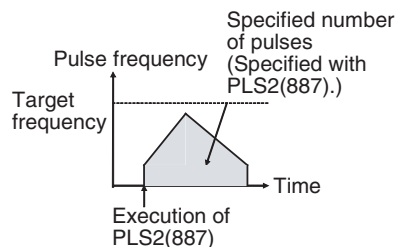

■ Switching from Continuous Mode Speed Control to Independent Mode Positioning

Example application	Frequency changes	Description	Procedure/instruction
Change from speed control to fixed distance positioning during operation	<p>Outputs the number of pulses specified in PLS2(887) (Both relative and absolute pulse specification can be used.)</p>	PLS2(887) can be executed during a speed control operation started with ACC(888) to change to positioning operation.	ACC(888) (Continuous) ↓ PLS2(887)
Fixed distance feed interrupt	<p>Execution of PLS2(887) with the following settings</p> <ul style="list-style-type: none"> • Number of pulses = number of pulses until stop • Relative pulse specification • Target frequency = present frequency • Acceleration rate = 0001 to 07D0 hex • Deceleration rate = target deceleration rate 		

Flags

Name	Label	Operation
Error Flag	ER	ON if the specified range for P, M, S, or F is exceeded. ON if PLS2(887) is executed for a port that is already outputting pulses for SPED(885) or ORG(889). ON if PLS2(887) is executed in an interrupt task when an instruction controlling pulse output is being executed in a cyclic task. ON if PLS2(887) is executed for an absolute pulse output but the origin has not been established.

Example

When CIO 000000 turns ON in the following programming example, PLS2(887) starts pulse output from pulse output 0 with an absolute pulse specification of 100,000 pulses. Pulse output is accelerated at a rate of 500 Hz every 4 ms starting at 200 Hz until the target speed of 50 kHz is reached. From the deceleration point, the pulse output is decelerated at a rate of 250 Hz every 4 ms starting until the starting speed of at 200 Hz is reached, at which point pulse output is stopped.

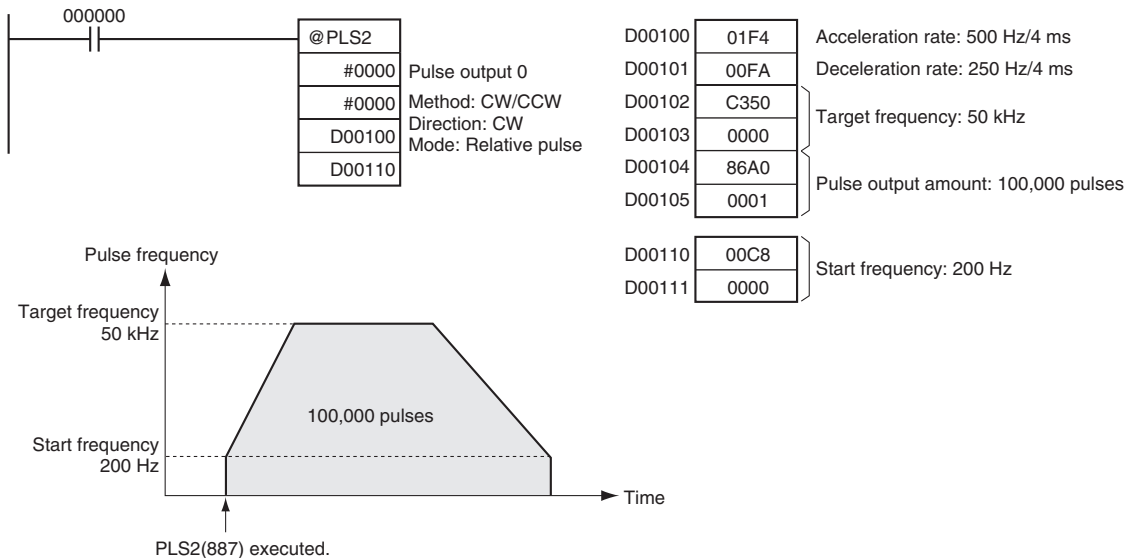

5-8 ACCELERATION CONTROL: ACC(888)

Purpose

ACC(888) outputs pulses to the specified output port at the specified frequency using the specified acceleration and deceleration rate. (Acceleration rate is the same as the deceleration rate.) Either independent mode positioning or constant mode speed control is possible. For positioning, ACC(888) is used in combination with PULS(886). ACC(888) can also be executed during pulse output to change the target frequency or acceleration/deceleration rate, enabling smooth (sloped) speed changes.

This instruction is supported by the CJ1M-CPU21/CPU22/CPU23 CPU Units only.

Ladder Symbol

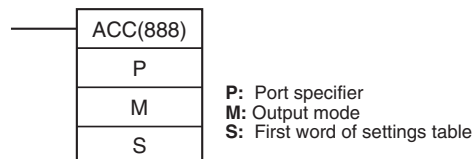

Variations

Variations	Executed Each Cycle for ON Condition	ACC(888)
	Executed Once for Upward Differentiation	@ACC(888)
	Executed Once for Downward Differentiation	Not supported
Immediate Refreshing Specification		Not supported

Applicable Program Areas

Block program areas	Step program areas	Subroutines	Interrupt tasks
OK	OK	OK	OK

Operands

P: Port Specifier

The port specifier specifies the port where the pulses will be output.

P	Port
0000 hex	Pulse output 0
0001 hex	Pulse output 1

M: Output Mode

The content of M specifies the parameters for the pulse output as follows:

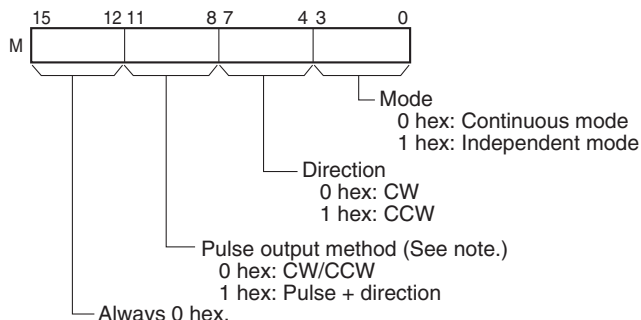

Note: Use the same pulse output method when using both pulse outputs 0 and 1.

S: First Word of Settings Table

The content of S to S+2 controls the pulse output as shown in the following diagrams.

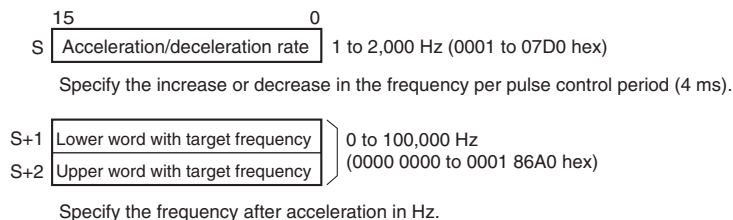

Operand Specifications

Area	P	M	S
CIO Area	---	---	CIO 0000 to CIO 6141
Work Area	---	---	W000 to W509
Holding Bit Area	---	---	H000 to H509
Auxiliary Bit Area	---	---	A000 to A957
Timer Area	---	---	T0000 to T4093
Counter Area	---	---	C0000 to C4093
DM Area	---	---	D00000 to D32765
EM Area without bank	---	---	---
EM Area with bank	---	---	---

Area	P	M	S
Indirect DM/EM addresses in binary	---	---	@ D00000 to @ D32767
Indirect DM/EM addresses in BCD	---	---	*D00000 to *D32767
Constants	See description of operand.	See description of operand.	---
Data Registers	---	---	---
Index Registers	---	---	---
Indirect addressing using Index Registers	---	---	,IR0 to ,IR15 -2048 to +2047 ,IR0 to -2048 to +2047 ,IR15 DR0 to DR15, IR0 to IR15 ,IR0+(++) to ,IR15+(++) ,-(--)IR0 to ,-(--)IR15

Description

ACC(888) starts pulse output on the port specified in P using the mode specified in M using the target frequency and acceleration/deceleration rate specified in S. The frequency is increased every pulse control period (4 ms) at the acceleration rate specified in S until the target frequency specified in S is reached.

Pulse output is started each time ACC(888) is executed. It is thus normally sufficient to use the differentiated version (@ACC(888)) of the instruction or an execution condition that is turned ON only for one scan.

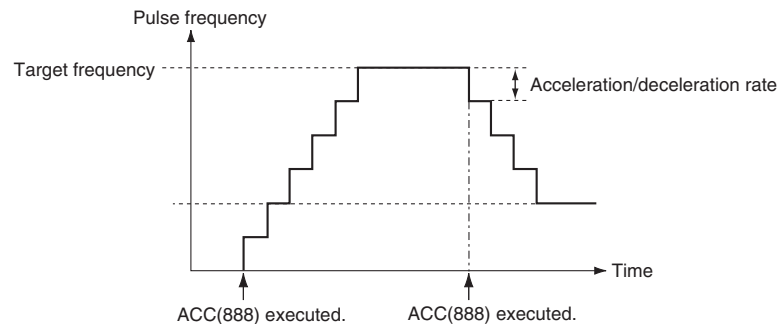

In independent mode, pulse output stops automatically when the specified number of pulses has been output. In continuous mode, pulse output continues until it is stopped from the program.

An error will occur if an attempt is made to switch between independent and continuous mode during pulse output.

With the CJ1M CPU Units, PLS2(887) can be executed during pulse output for ACC(888) in either independent or continuous mode, and during acceleration, constant speed, or deceleration. (See note.) ACC(888) can also be executed during pulse output for PLS2(887) during acceleration, constant speed, or deceleration.

Note Executing PLS2(887) during speed control with ACC(888) (continuous mode) with the same target frequency as ACC(888) can be used to achieved interrupt feeding of a fixed distance. Acceleration will not be performed by PLS2(887) for this application, but if the acceleration rate is set to 0, the Error Flag will turn ON and PLS2(887) will not be executed. Always set the acceleration rate to a value other than 0.

■ Continuous Mode Speed Control

Pulse output will continue until it is stopped from the program.

Note Pulse output will stop immediately if the CPU Unit is changed to PROGRAM mode.

Operation	Purpose	Application	Frequency changes	Description	Procedure/instruction
Starting pulse output	To output with specified acceleration and speed	Accelerating the speed (frequency) at a fixed rate		Outputs pulses and changes the frequency at a fixed rate.	ACC(888) (Continuous)
Changing settings	To change speed smoothly	Changing the speed smoothly during operation		Changes the frequency from the present frequency at a fixed rate. The frequency can be accelerated or decelerated.	ACC(888) or SPED(885) (Continuous) ↓ ACC(888) (Continuous)
		Changing the speed in a polyline curve during operation		Changes the acceleration or deceleration rate during acceleration or deceleration.	ACC(888) (Continuous) ↓ ACC(888) (Continuous)

Operation	Purpose	Application	Frequency changes	Description	Procedure/instruction
Stopping pulse output	To stop pulse output	Immediate stop		Immediately stops pulse output.	ACC(888) (Continuous) ↓ INI(880) (Continuous)
	To stop pulse output	Immediate stop		Immediately stops pulse output.	ACC(888) (Continuous) ↓ SPED(885) (Continuous, target frequency of 0)
	To stop pulse output smoothly	Decelerating to a stop		Decelerated pulse output to a stop. Note If ACC(888) started the operation, the original acceleration/deceleration rate will remain in effect. If SPED(885) started the operation, the acceleration/deceleration rate will be invalid and the pulse output will stop immediately.	ACC(888) (Continuous) ↓ ACC(888) (Continuous, target frequency of 0)

■ Independent Mode Positioning

When independent mode operation is started, pulse output will be continued until the specified number of pulses has been output.

The deceleration point is calculated from the number of output pulses and deceleration rate set in S and when that point is reached, the frequency is decreased every pulse control period (4 ms) at the deceleration rate specified in S until the specified number of points has been output, at which point pulse output is stopped.

- Note**
1. Pulse output will stop immediately if the CPU Unit is changed to PROGRAM mode.
 2. The number of output pulses must be set each time output is restarted.
 3. The number of output pulses must be set in advance with PULS(881). Pulses will not be output for ACC(888) if PULS(881) is not executed first.

4. The direction set in the ACC(888) operand will be ignored if the number of pulses is set with PULS(881) as an absolute value.

Operation	Purpose	Application	Frequency changes	Description	Procedure/instruction
Starting pulse output	Simple trapezoidal control	Positioning with trapezoidal acceleration and deceleration (Same rate used for acceleration and deceleration; no starting speed) The number of pulses cannot be changed during positioning.		Accelerates and decelerates at the same fixed rate and stops immediately when the specified number of pulses has been output. (See Note.) Note The target position (specified number of pulses) cannot be changed during positioning.	PULS(886) ↓ ACC(888) (Independent)
Changing settings	To change speed smoothly (with the same acceleration and deceleration rates)	Changing the target speed (frequency) during positioning (acceleration rate = deceleration rate)		ACC(888) can be executed during positioning to change the acceleration/deceleration rate and target frequency. The target position (specified number of pulses) is not changed.	PULS(886) ↓ ACC(888) or SPED(885) (Independent) ↓ ACC(888) (Independent)
Stopping pulse output	To stop pulse output. (Number of pulses setting is not preserved.)	Immediate stop		Pulse output is stopped immediately and the remaining number of output pulses is cleared.	PULS(886) ↓ ACC(888) (Independent) ↓ INI(880)
	To stop pulse output smoothly. (Number of pulses setting is not preserved.)	Decelerating to a stop		Decelerates the pulse output to a stop. Note If ACC(888) started the operation, the original acceleration/deceleration rate will remain in effect. If SPED(885) started the operation, the acceleration/deceleration rate will be invalid and the pulse output will stop immediately.	PULS(886) ↓ ACC(888) or SPED(885) (Independent) ↓ ACC(888) (Independent, independent, target frequency of 0) ↓ PLS2(887) ↓ ACC(888) (Independent, target frequency of 0)

Note Triangular Control

If the specified number of pulses is less than the number required to reach the target frequency and return to zero, the function will automatically reduce the acceleration/deceleration time and perform triangular control (acceleration and deceleration only.) An error will not occur.

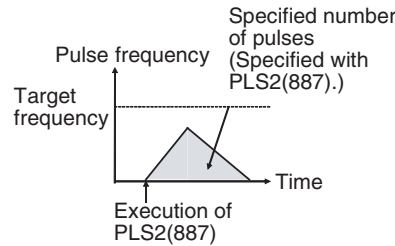

Flags

Name	Label	Operation
Error Flag	ER	ON if the specified range for P, M, or S is exceeded. ON if pulses are being output using ORG(889) for the specified port. ON if ACC(888) is executed to switch between independent and continuous mode for a port that is outputting pulses for SPED(885), ACC(888), or PLS2(887). ON if ACC(888) is executed in an interrupt task when an instruction controlling pulse output is being executed in a cyclic task. ON if ACC(888) is executed for an absolute pulse output in independent mode but the origin has not been established.

Example

When CIO 000000 turns ON in the following programming example, ACC(888) starts pulse output from pulse output 0 in continuous mode in the clockwise direction using the CW/CCW method. Pulse output is accelerated at a rate of 20 Hz every 4 ms until the target frequency of 500 Hz is reached. When CIO 000001 turns ON, ACC(888) changes to an acceleration rate of 10 Hz every 4 ms until the target frequency of 1,000 Hz is reached.

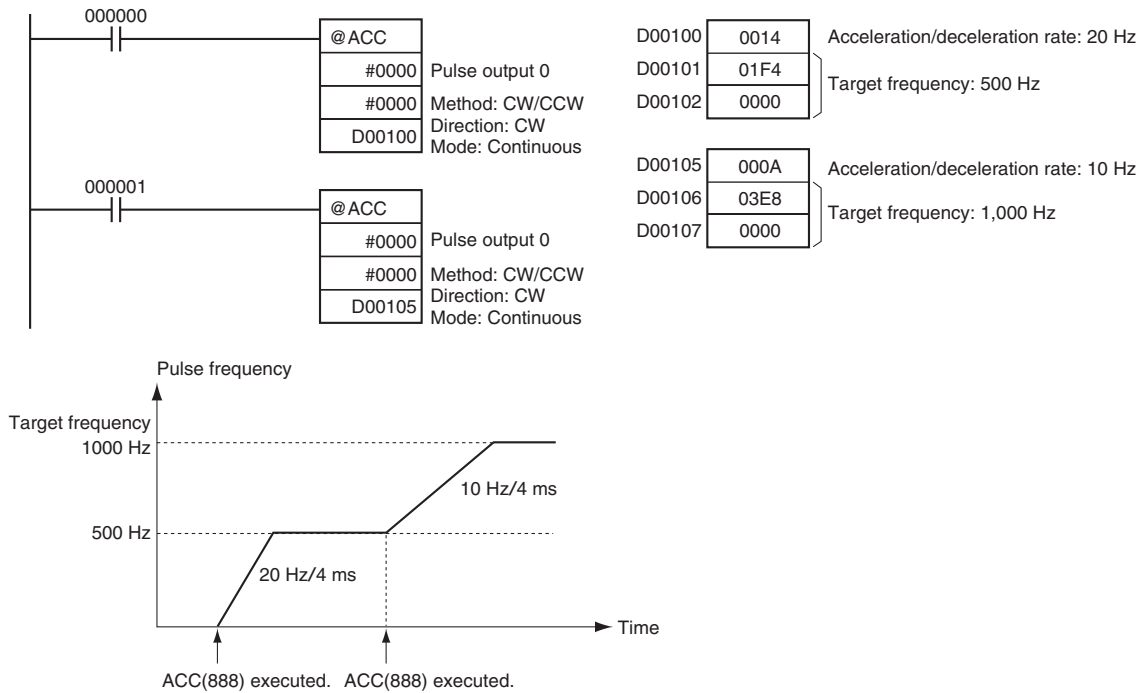

5-9 ORIGIN SEARCH: ORG(889)

Purpose

ORG(889) performs an origin search or origin return operation. This instruction is supported by the CJ1M-CPU21/CPU22/CPU23 CPU Units only.

■ Origin Search

Pulses are output using the specified method to actually drive the motor and establish the origin based on origin proximity input and origin input signals.

■ Origin Return

The positioning system is returned to the pre-established origin.

Ladder Symbol

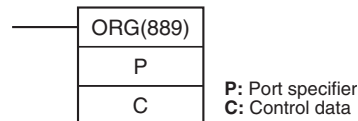

Variations

Variations	Executed Each Cycle for ON Condition	ORG(889)
	Executed Once for Upward Differentiation	@ORG(889)
	Executed Once for Downward Differentiation	Not supported
Immediate Refreshing Specification		Not supported

Applicable Program Areas

Block program areas	Step program areas	Subroutines	Interrupt tasks
OK	OK	OK	OK

Operands

P: Port Specifier

The port specifier specifies the port where the pulses will be output.

P	Port
0000 hex	Pulse output 0
0001 hex	Pulse output 1

C: Control Data

The value of C determines the origin search method.

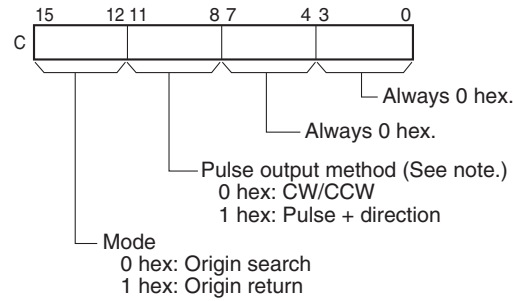

Note: Use the same pulse output method when using both pulse outputs 0 and 1.

Operand Specifications

Area	P	C
CIO Area	---	---
Work Area	---	---
Holding Bit Area	---	---
Auxiliary Bit Area	---	---
Timer Area	---	---
Counter Area	---	---
DM Area	---	---
EM Area without bank	---	---
EM Area with bank	---	---
Indirect DM/EM addresses in binary	---	---
Indirect DM/EM addresses in BCD	---	---
Constants	See description of operand.	See description of operand.
Data Registers	---	---
Index Registers	---	---
Indirect addressing using Index Registers	---	---

Description

ORG(889) performs an origin search or origin return operation for the port specified in P using the method specified in C.

The following parameters must be set in the PLC Setup before ORG(889) can be executed. Refer to the *CJ-series Built-in I/O Operation Manual* for details.

Origin search	Origin return
Origin Search Function Enable/Disable	Origin Search/Return Initial Speed
Origin Search Operating Mode	Origin Return Target Speed
Origin Search Operation Setting	Origin Return Acceleration Rate
Origin Detection Method	Origin Return Deceleration Rate
Origin Search Direction Setting	
Origin Search/Return Initial Speed	
Origin Search High Speed	
Origin Search Proximity Speed	
Origin Compensation	
Origin Search Acceleration Rate	
Origin Search Deceleration Rate	
Limit Input Signal Type	
Origin Proximity Input Signal Type	
Origin Input Signal Type	

An origin search or origin return is started each time ORG(889) is executed. It is thus normally sufficient to use the differentiated version (@ORG(889)) of the instruction or an execution condition that is turned ON only for one scan.

■ **Origin Search (Bits 12 to 15 of C = 0 hex)**

ORG(889) starts outputting pulses using the specified method at the Origin Search Initial Speed (1 in diagram). Pulse output is accelerated to the Origin Search High Speed using the Origin Search Acceleration Rate (2 in diagram). Pulse output is then continued at constant speed until the Origin Proximity Input Signal turns ON (3 in diagram), from which point pulse output is decelerated to the Origin Search Proximity Speed using the Origin Search Deceleration Rate (4 in diagram). Pulses are then output at constant speed until the Origin Input Signal turns ON (5 in diagram). Pulse output is stopped when the Origin Input Signal turns ON (6 in diagram).

When the origin search operation has been completed, the Error Counter Reset Output will be turned ON. The above operation, however, depends on the operating mode, origin detection method, and other parameters.

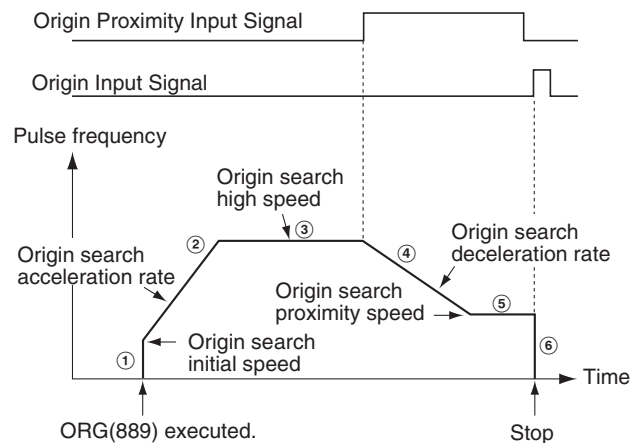

■ Origin Return (Bits 12 to 15 of C = 1 hex)

ORG(889) starts outputting pulses using the specified method at the Origin Return Initial Speed (1 in diagram). Pulse output is accelerated to the Origin Return Target Speed using the Origin Return Acceleration Rate (2 in diagram) and pulse output is continued at constant speed (3 in diagram). The deceleration point is calculated from the number of pulses remaining to the origin and the deceleration rate and when that point is reached, the pulse output is decelerated (4 in diagram) at the Origin Return Deceleration Rate until the Origin Return Start Speed is reached, at which point pulse output is stopped at the origin (5 in diagram).

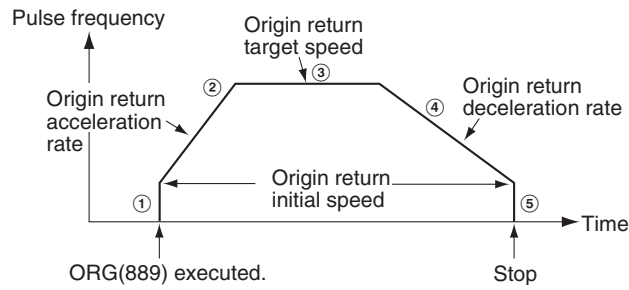

Flags

Name	Label	Operation
Error Flag	ER	ON if the specified range for P or C is exceeded. ON if ORG(889) is specified for a port during pulse output for SPED(885), ACC(888), or PLS2(887). ON if ORG(889) is executed in an interrupt task when an instruction controlling pulse output is being executed in a cyclic task. ON if the origin search or origin return parameters set in the PLC Setup are not within range. ON if the Origin Search High Speed is less than or equal to the Origin Search Proximity Speed or the Origin Search Proximity Speed is less than or equal to the Origin Search Initial Speed. ON if the Origin Return Target speed is less than or equal to the Origin Return Initial Speed. ON if an origin return operation is attempted when the origin has not been established.

Example

When CIO 000000 turns ON in the following programming example, ORG(889) starts an origin return operation for pulse output 0 by outputting pulses using the CW/CCW method. According to the PLC Setup, the initial speed is 100 pps, the target speed is 200 pps, and the acceleration and deceleration rates are 50 Hz/4 ms.

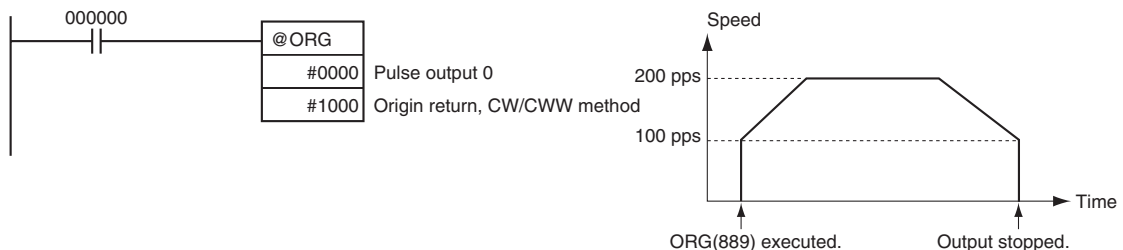

The PLC Setup parameters are as follows:

Parameter	Setting
Pulse Output 0 Starting Speed for Origin Search and Origin Return	0000 0064 hex: 100 pps
Pulse Output 0 Origin Return Target Speed	0000 00C8 hex: 200 pps
Pulse Output 0 Origin Return Acceleration Rate	0032 hex: 50 hex/4 ms
Pulse Output 0 Origin Return Deceleration Rate	0032 hex: 50 hex/4 ms

5-10 PULSE WITH VARIABLE DUTY FACTOR: PWM(891)

Purpose

PWM(891) is used to output pulses with the specified duty factor from the specified port.

This instruction is supported by the CJ1M-CPU21/CPU22/CPU23 CPU Units only.

Ladder Symbol

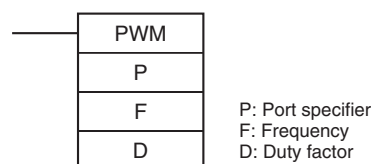

Variations

Variations	Executed Each Cycle for ON Condition	PWM(891)
	Executed Once for Upward Differentiation	@PWM(891)
	Executed Once for Downward Differentiation	Not supported
Immediate Refreshing Specification		Not supported

Applicable Program Areas

Block program areas	Step program areas	Subroutines	Interrupt tasks
OK	OK	OK	OK

Operands

P: Port Specifier

The port specifier specifies the port where the pulses will be output.

P	Port
0000 hex	Pulse output 0 (duty factor: in increments of 1%)
0001 hex	Pulse output 1 (duty factor: in increments of 1%)
1000 hex (CJ1M CPU Unit Ver. 2.0 or later)	Pulse output 0 (duty factor: in increments of 0.1%)
1001 hex (CJ1M CPU Unit Ver. 2.0 or later)	Pulse output 1 (duty factor: in increments of 0.1%)

Note Pulse output 1 can be used only with the CJ1M-CPU22/23.

F: Frequency

F specifies the frequency of the pulse output between 0.1 and 6,553.5 Hz (0.1 Hz units, 0001 to FFFF hex). The accuracy of the PMW(891) waveform that is actually output (ON duty +5%/–0%) applies only to 0.1 to 1,000.0 Hz due to limitations in the output circuits.

D: Duty Factor

D specifies the duty factor of the pulse output, i.e., the percentage of time that the output is ON. D must be between 0% and 100% (0000 to 0064 hex)

Operand Specifications

Area	P	F	D
CIO Area	---	CIO 0000 to CIO 6143	CIO 0000 to CIO 6143
Work Area	---	W000 to W511	W000 to W511
Holding Bit Area	---	H000 to H511	H000 to H511
Auxiliary Bit Area	---	A000 to A959	A000 to A959
Timer Area	---	T0000 to T4095	T0000 to T4095
Counter Area	---	C0000 to C4095	C0000 to C4095
DM Area	---	D00000 to D32767	D00000 to D32767
EM Area without bank	---	---	---
EM Area with bank	---	---	---
Indirect DM/EM addresses in binary	---	@ D00000 to @ D32767	@ D00000 to @ D32767
Indirect DM/EM addresses in BCD	---	*D00000 to *D32767	*D00000 to *D32767
Constants	See description of operand.	0000 to FFFF hex	<ul style="list-style-type: none"> Pre-Ver. 2.0 CPU Units 0000 to 0064 hex CPU Units Ver. 2.0 or later 0000 to 03E8 hex
Data Registers	---	DR0 to DR15	DR0 to DR15
Index Registers	---	---	---
Indirect addressing using Index Registers	---	,IR0 to ,IR15 -2048 to +2047 ,IR0 to -2048 to +2047 ,IR15 DR0 to DR15, IR0 to IR15 ,IR0+(++) to ,IR15+(++) ,-(--)IR0 to ,-(--)IR15	

Description

PWM(891) outputs the frequency specified in F at the duty factor specified in D from the port specified in P. PWM(891) can be executed during duty-factor pulse output to change the duty factor without stopping pulse output. Any attempts to change the frequency will be ignored.

Pulse output is started each time PWM(891) is executed. It is thus normally sufficient to use the differentiated version (@PWM(891)) of the instruction or an execution condition that is turned ON only for one scan.

The pulse output will continue either until INI(880) is executed to stop it (C = 0003 hex: stop pulse output) or until the CPU Unit is switched to PROGRAM mode.

Flags

Name	Label	Operation
Error Flag	ER	ON if the specified range for P, F, or D is exceeded. ON if pulses are being output using ORG(889) for the specified port. ON if PWM(891) is executed in an interrupt task when an instruction controlling pulse output is being executed in a cyclic task.

Example

When CIO 000000 turns ON in the following programming example, PWM(891) starts pulse output from pulse output 0 at 200 Hz with a duty factor of 50%. When CIO 000001 turns ON, the duty factor is changed to 25%.

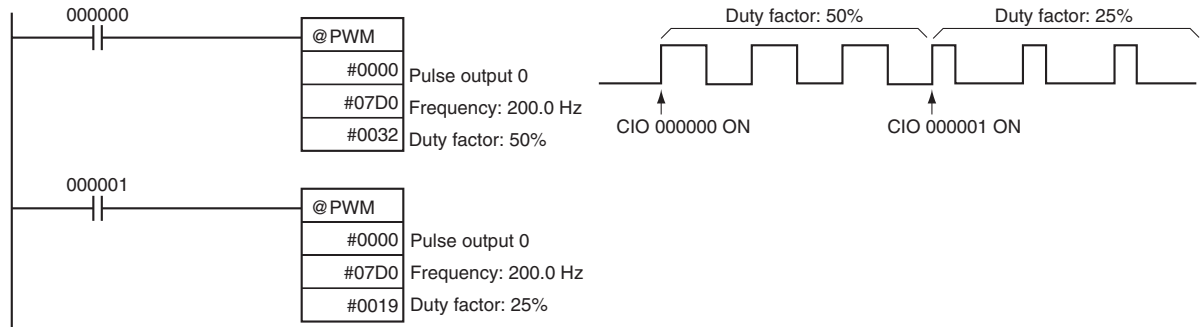

SECTION 6

Built-in I/O Function Descriptions

This section describes the application of built-in I/O in detail.

6-1	Built-in Inputs	126
6-1-1	Overview	126
6-1-2	General-purpose Inputs	126
6-1-3	Interrupt Inputs	128
6-1-4	High-speed Counter Inputs	131
6-1-5	Quick-response Inputs	143
6-1-6	Hardware Specifications	144
6-2	Built-in Outputs	144
6-2-1	Overview	144
6-2-2	General-purpose Outputs	145
6-2-3	Pulse Outputs	145
6-2-4	Variable Duty Ratio Pulse Outputs (PWM(891) Outputs)	167
6-3	Origin Search and Origin Return Functions	169
6-3-1	Overview	169
6-3-2	Origin Search	169
6-3-3	Origin Search Error Processing	185
6-3-4	Origin Search Examples	187
6-3-5	Origin Return	189

6-1 Built-in Inputs

6-1-1 Overview

There are 4 kinds of built-in inputs:

- General-purpose inputs
- Interrupt inputs (direct mode or counter mode)
- High-speed counter inputs (with the frequency measurement function)
- Quick-response inputs

The built-in inputs are allocated bits 00 to 09 of CIO 2960. The PLC Setup settings specify which kind of input is used for each bit.

6-1-2 General-purpose Inputs

Overview

The general-purpose input function treats inputs just like inputs in an Input Unit. The input signals are read during regular I/O refreshing and the input status is reflected in I/O memory at that time. The input time constant (ON response time) can be set for the general-purpose inputs.

Bit Allocations

Code	Word address	Bit	Function
IN0	CIO 2960	00	General-purpose input 0
IN1		01	General-purpose input 1
IN2		02	General-purpose input 2
IN3		03	General-purpose input 3
IN4		04	General-purpose input 4
IN5		05	General-purpose input 5
IN6		06	General-purpose input 6
IN7		07	General-purpose input 7
IN8		08	General-purpose input 8
IN9		09	General-purpose input 9

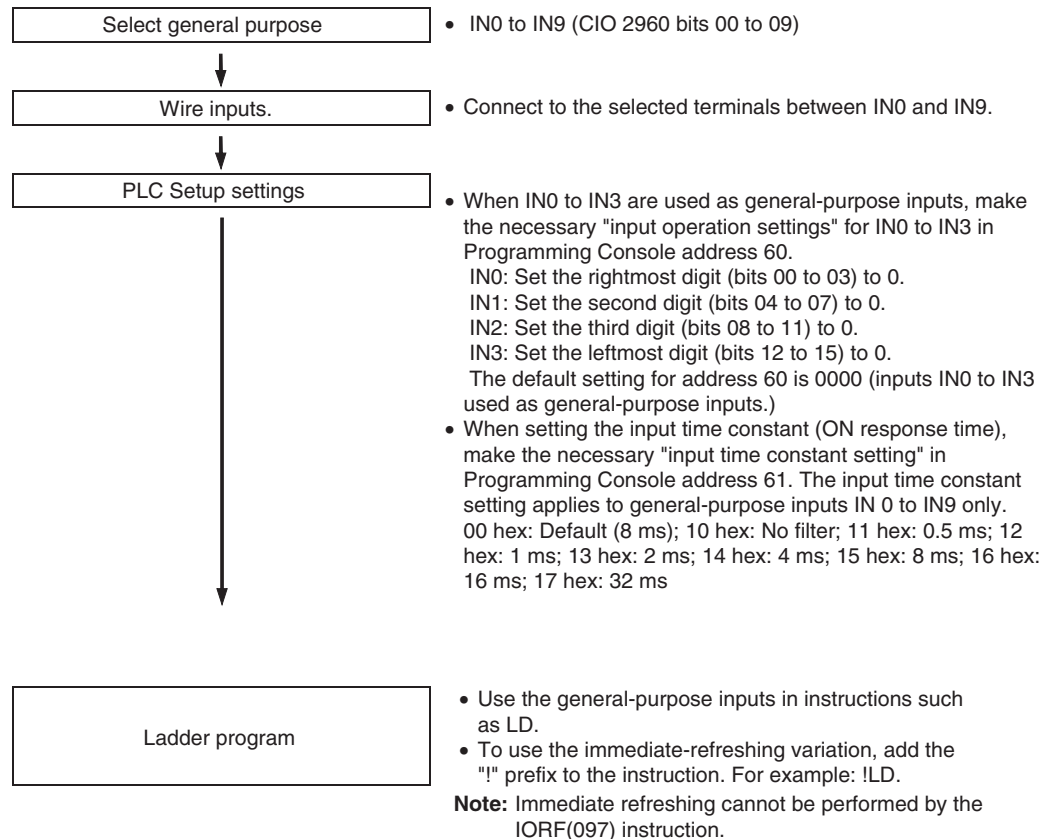
Procedure**Restrictions on General-purpose Inputs**

- General-purpose inputs 0 to 3 cannot be used when built-in inputs IN0 to IN3 are being used as interrupt inputs or quick-response inputs.
- General-purpose inputs 8 and 9 cannot be used when high-speed counter input 0 is being used. Furthermore, general-purpose input 3 cannot be used if the high-speed counter 0 reset method is set to Phase-Z signal + Software reset.
 General-purpose inputs 6 and 7 cannot be used when high-speed counter input 1 is being used. General-purpose input 2 cannot be used if the high-speed counter 1 reset method is set to Phase-Z signal + Software reset.
- General-purpose inputs 0 and 1 cannot be used when the origin search function is enabled for pulse output 0 (enabled in the PLC Setup). Also, general-purpose input 4 cannot be used when operating mode 2 has been specified, i.e., the Positioning Completed Signal is being used.
 General-purpose inputs 2 and 3 cannot be used when the origin search function is enabled for pulse output 1 (enabled in the PLC Setup). Also, general-purpose input 5 cannot be used when operating mode 2 has been specified, i.e., the Positioning Completed Signal is being used.

Specifications

Item	Specifications
Number of inputs	10 inputs
Allocated data area	CIO 2960 bits 00 to 09
Input time constant (ON response time)	Default: 8 ms The following settings can be made in the PLC Setup: 0 ms (no filter), 0.5 ms, 1 ms, 2 ms, 4 ms, 8 ms, 16 ms, or 32 ms.

6-1-3 Interrupt Inputs

Interrupt Inputs (Direct Mode)

Overview

This function starts an interrupt task when the corresponding input signal (up or down differentiated) is received. The four interrupt inputs control interrupt tasks 140 to 143. (The interrupt task numbers cannot be changed.)

Bit Allocations

Code	Word address	Bit	Function
IN0	CIO 2960	00	Interrupt input 0
IN1		01	Interrupt input 1
IN2		02	Interrupt input 2
IN3		03	Interrupt input 3

Procedure

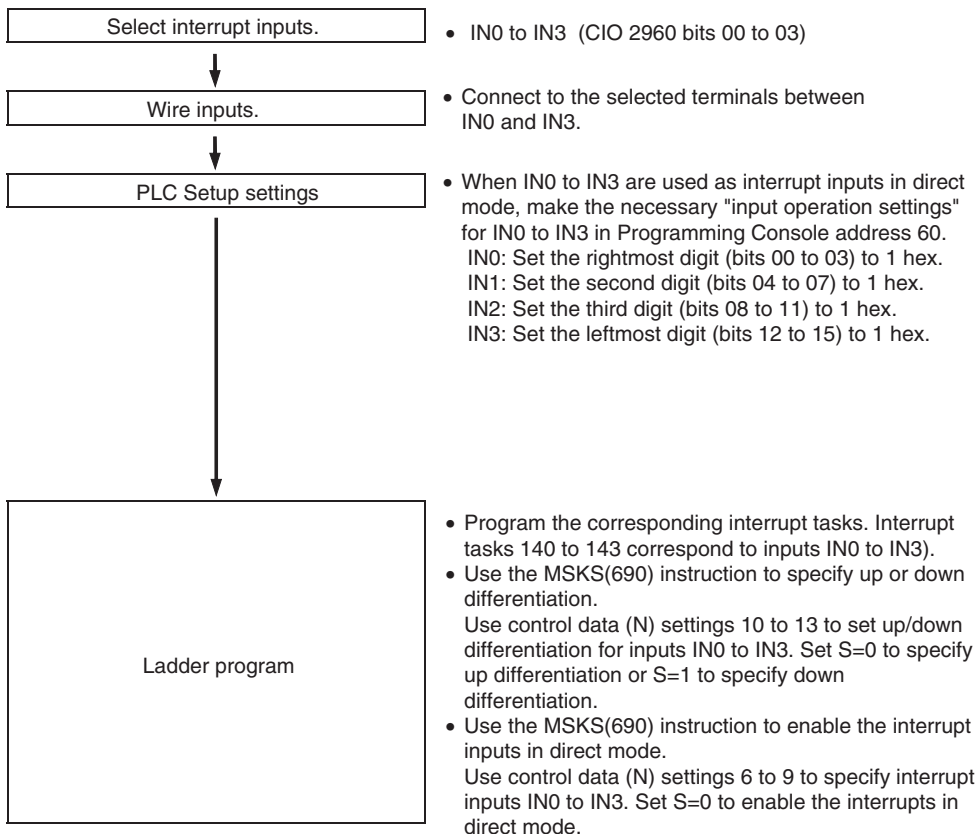

Note Use the MSKS(690) instruction to select the interrupt mode (direct mode or counter mode.)

Restrictions on Interrupt Inputs (Direct Mode)

- Interrupt inputs 0 to 3 cannot be used when built-in inputs IN0 to IN3 are being used as general-purpose inputs or quick-response inputs.
- Interrupt input 3 cannot be used when high-speed counter input 0 is being used and the high-speed counter 0 reset method is set to Phase-Z signal + Software reset.
Interrupt input 2 cannot be used when high-speed counter input 1 is being used and the high-speed counter 1 reset method is set to Phase-Z signal + Software reset.
- Interrupt inputs 0 and 1 cannot be used when the origin search function is enabled for pulse output 0 (enabled in the PLC Setup).
Interrupt inputs 2 and 3 cannot be used when the origin search function is enabled for pulse output 1 (enabled in the PLC Setup).

Specifications

Item	Specifications
Number of inputs	4 inputs (The 4 input terminals are shared with the quick-response inputs, high-speed counter (Phase-Z signal), and general-purpose inputs.)
Allocated data area	CIO 2960 bits 00 to 03
Interrupt detection	Up differentiation or down differentiation

Interrupt Task Numbers

Input bit	Interrupt task number
CIO 2960 bit 00	140
CIO 2960 bit 01	141
CIO 2960 bit 02	142
CIO 2960 bit 03	143

Interrupt Inputs (Counter Mode)

Overview

This function counts input signals (up or down differentiated) and starts an interrupt task when the counter PV reaches the SV (or 0 when decrementing.)
The four interrupt inputs control interrupt tasks 140 to 143. The interrupt task numbers cannot be changed.

Bit Allocations

Code	Word address	Bit	Function
IN0	CIO 2960	00	Interrupt input 0
IN1		01	Interrupt input 1
IN2		02	Interrupt input 2
IN3		03	Interrupt input 3

Procedure

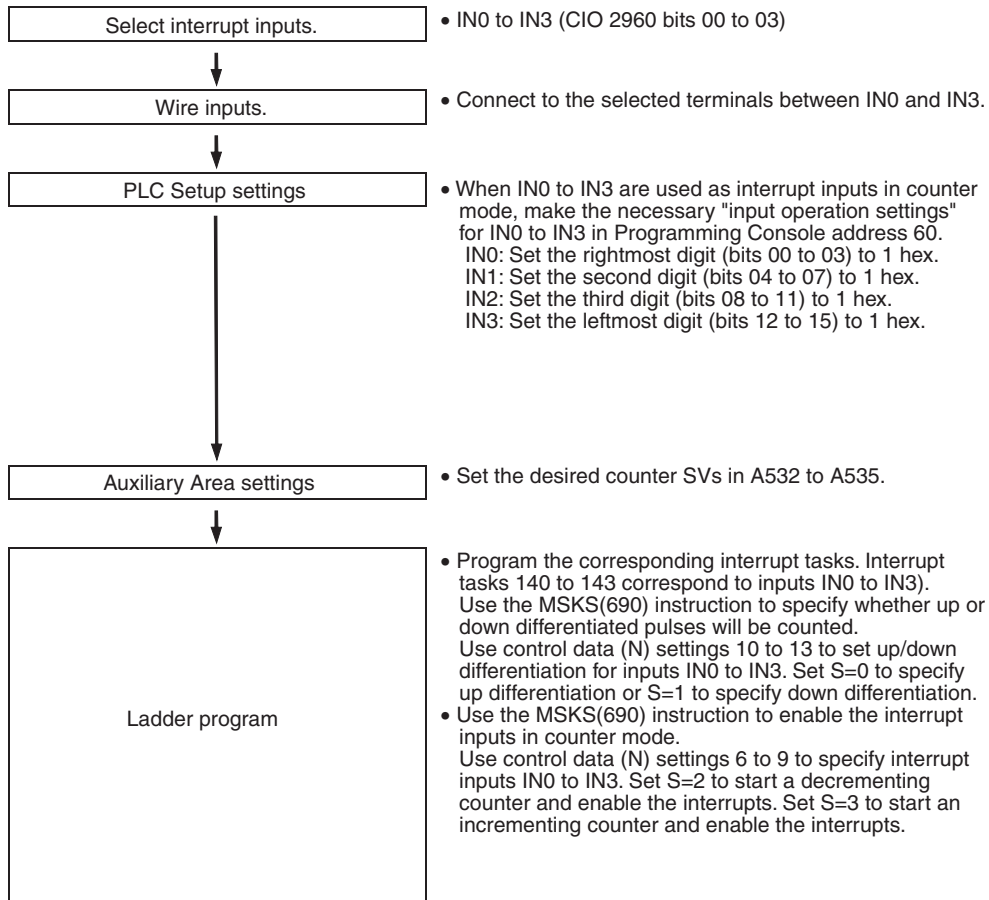

- Note**
1. Use the MSKS(690) instruction to select the interrupt mode (direct mode or counter mode.)
 2. To enable setting interrupt inputs, the power supply must be turned OFF and then back ON after transferring the PLC Setup.

Restrictions on Interrupt Inputs (Counter Mode)

- Interrupt inputs 0 to 3 cannot be used when built-in inputs IN0 to IN3 are being used as general-purpose inputs or quick-response inputs.
- Interrupt input 3 cannot be used when high-speed counter input 0 is being used and the high-speed counter 0 reset method is set to Phase-Z signal + Software reset.
 Interrupt input 2 cannot be used when high-speed counter input 1 is being used and the high-speed counter 1 reset method is set to Phase-Z signal + Software reset.
- Interrupt inputs 0 and 1 cannot be used when the origin search function is enabled for pulse output 0 (enabled in the PLC Setup).
 Interrupt inputs 2 and 3 cannot be used when the origin search function is enabled for pulse output 1 (enabled in the PLC Setup).

Specifications

Item	Specifications
Number of inputs	4 inputs (The 4 input terminals are shared with the quick-response inputs, high-speed counter (Phase-Z signal), and general-purpose inputs.)
Allocated data area	CIO 2960 bits 00 to 03
Count pulse detection	Up differentiation or down differentiation
Count method	Incrementing or decrementing (Set with the MSKS(690) instruction.)
Count range	0001 to FFFF hex (16 bits) (The SVs are set in Auxiliary Area words A532 to A535.)
Response frequency	Single phase: 1 kHz x 4 inputs
Storage priority for the interrupt input (counter mode) PVs	A536 to A539 <ul style="list-style-type: none"> •PVs can be read with the PRV(881) instruction. •PVs can be changed with the INI(880) instruction. <p>Note</p> <ul style="list-style-type: none"> •PVs are retained when the power is turned ON. •PVs are cleared when operation starts. •PVs are refreshed when an interrupt occurs. •PVs are refreshed when the INI(880) instruction is executed to change the PV.

Interrupt Task Numbers

Input bit	Interrupt task number
CIO 2960 bit 00	140
CIO 2960 bit 01	141
CIO 2960 bit 02	142
CIO 2960 bit 03	143

6-1-4 High-speed Counter Inputs

Overview

This function counts pulse signals input at the built-in input terminals.

Any one of the following input signals can be selected as the counter input mode.

- Differential phase inputs (4x)
- Pulse + direction inputs
- Up/Down pulse inputs
- Increment pulse inputs

The present counts are contained in the High-speed Counter PVs (A270 to A273.)

- The counting mode can be set to linear mode or ring mode counting.
- The counter reset method can be set to Phase-Z signal + Software reset or Software reset.
- An interrupt task can be started when the high-speed counter PV meets the preset comparison condition. Either one of these comparison methods can be used:
 - Target value comparison
 - Range comparison
- Counting can be stopped temporarily with the counters Gate Bit (Gate function.)

Bit Allocations

Code	Word address	Bit	Pulse input mode			
			Differential phase	Pulse + direction	Up/down input	Increment
IN6	CIO 2960	06	High-speed counter 1 Phase A	High-speed counter 1 Count input	High-speed counter 1 Increment input	High-speed counter 1 Count input
IN7		07	High-speed counter 1 Phase B	High-speed counter 1 Direction input	High-speed counter 1 Decrement input	---
IN2		02	High-speed counter 1 Phase Z	High-speed counter 1 Reset input	High-speed counter 1 Reset input	High-speed counter 1 Reset input
IN8		08	High-speed counter 0 Phase A	High-speed counter 0 Count input	High-speed counter 0 Increment input	High-speed counter 0 Count input
IN9		09	High-speed counter 0 Phase B	High-speed counter 0 Direction input	High-speed counter 0 Decrement input	---
IN3		03	High-speed counter 0 Phase Z	High-speed counter 0 Reset input	High-speed counter 0 Reset input	High-speed counter 0 Reset input

Procedure

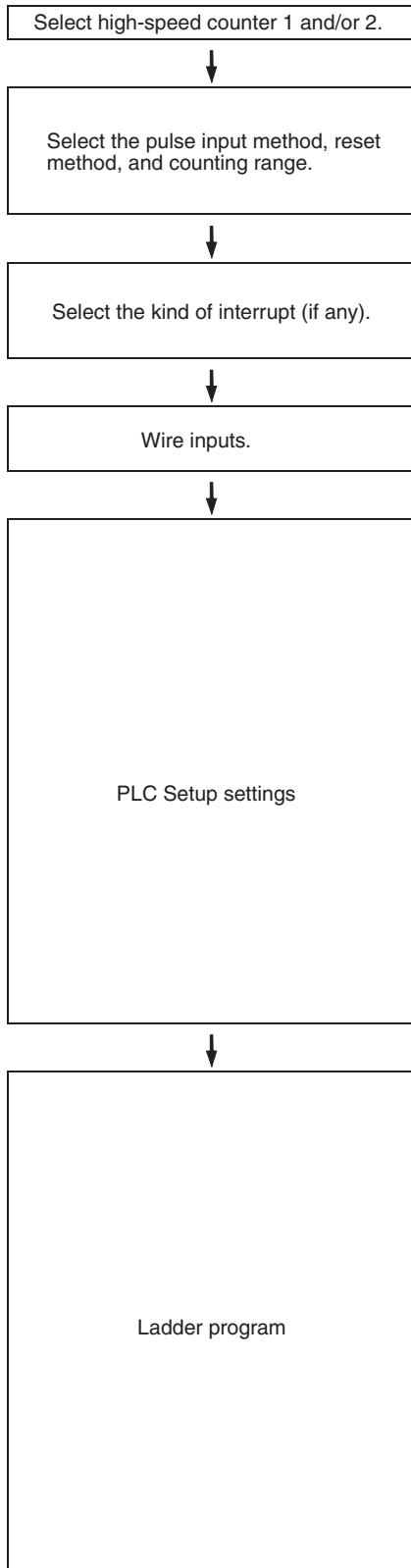

- Pulse input methods: Differential phase (4x), Pulse + direction, Up/Down, or Increment
- Reset methods: Phase-Z + Software reset or Software reset
- Counting ranges: Linear mode or Ring mode

- No interrupt
- Target value comparison interrupt
- Range comparison interrupt

- For high-speed counter 0, connect IN3, IN8, and IN9. For high-speed counter 1, connect IN2, IN6, and IN7.

- Enable high-speed counter 0 and/or 1.
 High-speed Counter 0 (1) Enable/Disable:
 Bits 12 to 15 of Programming Console address 50 (53).
 1 Hex: Enable the high-speed counter (60 kHz.)
 2 Hex: Enable the high-speed counter (100 kHz.)
 Set the pulse input method(s).
- High-speed Counter 0 (1) Pulse Input Mode:
 Bits 00 to 03 of Programming Console address 50 (53).
 0 Hex: Differential phase (4x)
 1 Hex: Pulse + direction
 2 Hex: Up/Down
 3 Hex: Increment
 Set the reset method(s).
- High-speed Counter 0 (1) Reset Method:
 Bits 04 to 07 of Programming Console address 50 (53).
 0 Hex: Phase-Z + Software reset
 1 Hex: Software reset
 Set the counting range(s).
- High-speed Counter 0 (1) Counting Mode:
 Bits 04 to 07 of Programming Console address 50 (53).
 0 Hex: Linear mode
 1 Hex: Ring mode

- Program the interrupt task (with any interrupt number between 0 and 255) to be executed when using a target value comparison or range comparison interrupts.
- When performing target value comparisons, execute the CTBL(882) instruction with C=0000 Hex to register a target value comparison table and start the comparison.
- When performing range value comparisons, execute the CTBL(882) instruction with C=0001 Hex to register a range comparison table and start the comparison.
- To register a target value comparison table without starting the comparison, execute the CTBL(882) instruction with C=0002 Hex.
- To register a range comparison table without starting the comparison, execute the CTBL(882) instruction with C=0003 Hex.
- The INI(880) instruction can be used to change the PV.
- The INI(880) instruction can be used to start comparison with the registered target value comparison table or range comparison table.
- The PRV(881) instruction can be used to read the high-speed counter PVs, read the status of the high-speed counter comparison operation, or read the range-comparison results.
- The High-speed Counter Gate Bit (A53108 and A53109) can be turned ON to stop counting pulses input to high speed counter 0 and 1.

Restrictions on High-speed Counter Inputs

- The Phase-Z signal + Software reset method cannot be used when high speed counters 0/1 are operating in Differential Phase or Pulse + Direction Input Modes and the origin search function is enabled for pulse output 1. The Phase-Z signal + Software reset method can be used when high speed counters 0/1 are operating in Incrementing or Up/Down Input Modes.
- General-purpose inputs 8 and 9 cannot be used when high-speed counter input 0 is being used. Furthermore, general-purpose input 3, interrupt input 3, and quick-response input 3 cannot be used if the high-speed counter 0 reset method is set to Phase-Z signal + Software reset. General-purpose inputs 6 and 7 cannot be used when high-speed counter input 1 is being used. Furthermore, general-purpose input 2, interrupt input 2, and quick-response input 2 cannot be used if the high-speed counter 0 reset method is set to Phase-Z signal + Software reset.

Specifications

Item		Specification				
Number of high-speed counters		2 (High-speed counters 0 and 1)				
Allocated data area		CIO 2960 (The bits actually used depend on the pulse input mode selected.)				
Pulse input mode (Selected in the PLC Setup)		Differential phase inputs	Up/down inputs	Pulse + direction inputs	Increment inputs	
Input pin allocation	High-speed counter 0	High-speed counter 1				
	24 V: 25 LD+: 27 0 V/LD-: 29	24 V: 19 LD+: 21 0 V/LD-: 23	Phase-A input	Increment pulse input	Pulse input	Increment pulse input
	24 V: 26 LD+: 28 0 V/LD-: 30	24 V: 20 LD+: 22 0 V/LD-: 24	Phase-B input	Decrement pulse input	Direction input	---
	24 V: 8 LD+: 10 0 V/LD-: 12	24 V: 7 LD+: 9 0 V/LD-: 11	Phase-Z input	Reset input	Reset input	Reset input
Input method		Differential phase 4X (Fixed)	Single-phase input + Direction input	Single-phase input X 2	Single-phase input	
Response frequency	Line-driver inputs	50 kHz	100 kHz	100 kHz	100 kHz	
	24-V DC inputs	30 kHz	60 kHz	60 kHz	60 kHz	
Counting mode		Linear mode or Ring mode (Select in the PLC Setup.)				
Count value		Linear mode: 80000000 to 7FFFFFFF hex Ring mode: 00000000 to Ring SV (The Ring SV is set in the PLC Setup and the setting range is 00000001 to FFFFFFFF hex.)				
High-speed counter PV storage locations		High-speed counter 0: A271 (leftmost 4 digits) and A270 (rightmost 4 digits) High-speed counter 1: A273 (leftmost 4 digits) and A272 (rightmost 4 digits) Target value comparison interrupts or range comparison interrupts can be executed based on these PVs. Note The PVs are refreshed in the overseeing processes at the beginning of each cycle. Use the PRV(881) instruction to read the most recent PVs.				
		Data format: 8 digit hexadecimal Range in linear mode: 80000000 to 7FFFFFFF hex Range in ring mode: 00000000 to Ring SV				

Item		Specification
Control method	Target value comparison	Up to 48 target values and corresponding interrupt task numbers can be registered.
	Range comparison	Up to 8 ranges can be registered, with a separate upper limit, lower limit, and interrupt task number for each range.
Counter reset method		Select one of the following methods in the PLC Setup. •Phase-Z + Software reset The counter is reset when the phase-Z input goes ON while the Reset Bit (see below) is ON. •Software reset The counter is reset when the Reset Bit (see below) goes ON. (Set the counter reset method in the PLC Setup.) Reset Bits: The High-speed Counter 0 Reset Bit is A53100 and the High-speed Counter 1 Reset Bit is A53101. Note Operation can be set to stop or continue the comparison operation when the high-speed counter is reset. (CJ1M CPU Unit Ver. 2.0 or later)

Pulse Input Modes

Differential Phase Mode

The differential phase mode uses two phase signals (phase A and phase B) and increments/decrements the count according to the status of these two signals.

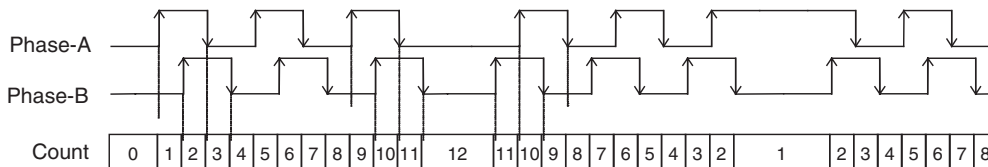

Conditions for Incrementing/Decrementing the Count

Phase A	Phase B	Count value
↑	L	Increment
H	↑	Increment
↓	H	Increment
L	↓	Increment
L	↑	Decrement
↑	H	Decrement
H	↓	Decrement
↓	L	Decrement

Pulse + Direction Mode

The pulse + direction mode uses a direction signal input and pulse signal input. The count is incremented or decremented depending on the status (ON or OFF) of the direction signal.

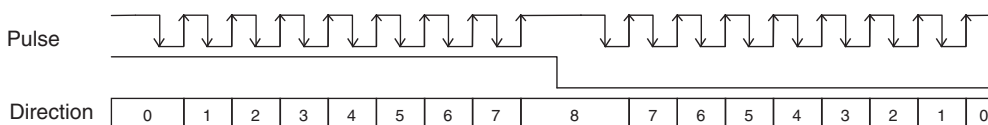

Conditions for Incrementing/Decrementing the Count

Direction signal	Pulse signal	Count value
↑	L	No change
H	↑	Increment
↓	H	No change
L	↓	No change
L	↑	Decrement
↑	H	No change
H	↓	No change
↓	L	No change

- The count is incremented when the direction signal is ON and decremented when it is OFF.
- Only up-differentiated pulses (rising edges) can be counted.

Up/Down Mode

The up/down mode uses two signals, an increment pulse input and a decrement pulse input.

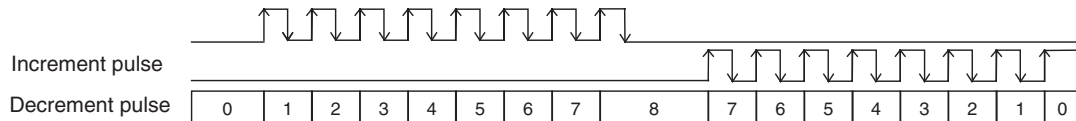

Conditions for Incrementing/Decrementing the Count

Decrement pulse	Increment pulse	Count value
↑	L	Decrement
H	↑	Increment
↓	H	No change
L	↓	No change
L	↑	Increment
↑	H	Decrement
H	↓	No change
↓	L	No change

- The count is incremented for each increment pulse input and decremented when for each decrement pulse input.
- Only up-differentiated pulses (rising edges) can be counted.

Increment Mode

The increment mode counts single-phase pulse signal inputs. This mode only increments the count.

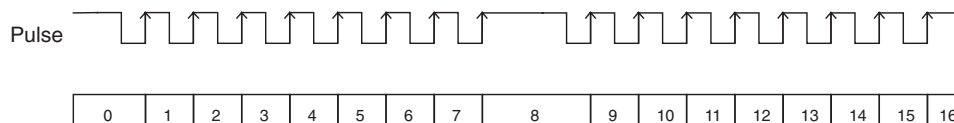

Conditions for Incrementing/Decrementing the Count

Pulse	Count value
↑	Increment
H	No change
↓	No change
L	No change

- Only up-differentiated pulses (rising edges) can be counted.

Note With CJ1M CPU Unit Ver. 2.0, the count of the high-speed counter can be monitored to see if it is currently being incremented or decremented. The count in the current cycle is compared with the count in the previous cycle to determine if it is being incremented or decremented. The results is shown in the High-speed Counter 0 Count Direction Flag (A27410) and the High-speed Counter 1 Count Direction Flag (A27510). (0: Decrementing, 1: Incrementing)

Counting Modes

Linear Mode

Input pulses can be counted in the range between the lower limit and upper limit values. If the pulse count goes beyond the lower/upper limit, an under-flow/overflow will occur and counting will stop.

Lower and Upper Limits of the Range

The following diagrams show the lower limit and upper limit values for increment mode and up/down mode.

Increment Mode



Up/Down Mode

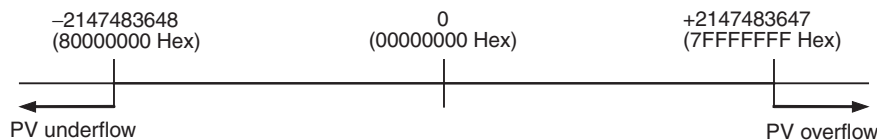

Ring Mode

Input pulses are counted in a loop within the set range. The loop operates as follows:

- If the count is incremented from the max. ring count, the count will be reset to 0 automatically and incrementing will continue.
- If the count is decremented from 0, the count will be set to the max. ring count automatically and decrementing will continue.

Consequently, underflows and overflows cannot occur when ring mode is used.

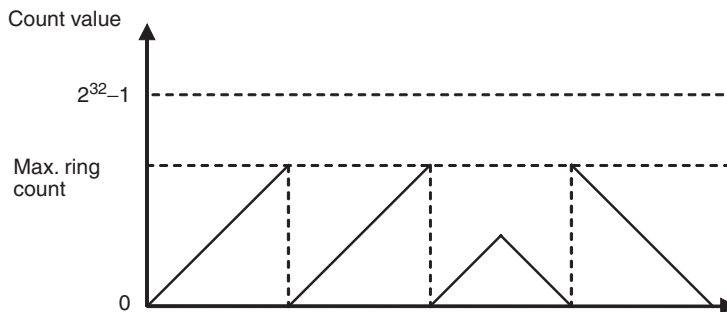

Max. Ring Count

Use the PLC Setup to set the max. ring count, which is the max. value of the input pulse counting range. The max. ring count can be set to any value between 00000001 and FFFFFFFF hex.

Restrictions

- There are no negative values in ring mode.
- If the max. ring count is set to 0 in the PLC Setup, the counter will operate with a max. ring count of FFFFFFFF hex.

Reset Methods

Phase-Z Signal + Software Reset

The high-speed counter's PV is reset when the phase-Z signal (reset input) goes from OFF to ON while the corresponding High-speed Counter Reset Bit (A53100 or A53101) is ON.

The CPU Unit recognizes the ON status of the High-speed Counter Reset Bit only at the beginning of the PLC cycle during the overseeing processes. Consequently, when the Reset Bit is turned ON in the ladder program, the phase-Z signal (bit 02 or 03 of CIO 2960) does not become effective until the next PLC cycle.

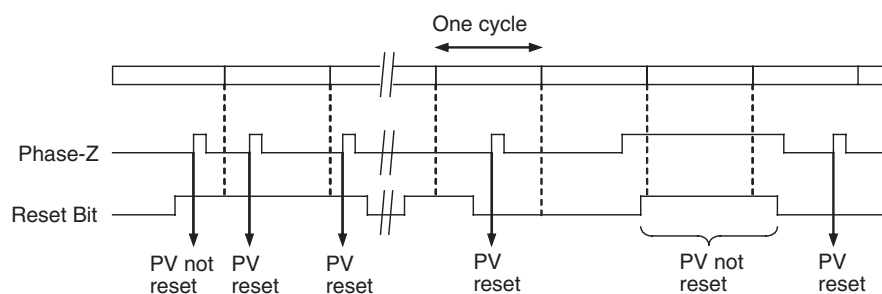

Software Reset

The high-speed counter's PV is reset when the corresponding High-speed Counter Reset Bit (A53100 or A53101) goes from OFF to ON.

The CPU Unit recognizes the OFF-to-ON transition of the High-speed Counter Reset Bit only at the beginning of the PLC cycle during the overseeing processes. Reset processing is performed at the same time. The OFF-to-ON transition will not be recognized if the Reset Bit goes OFF again within the same cycle.

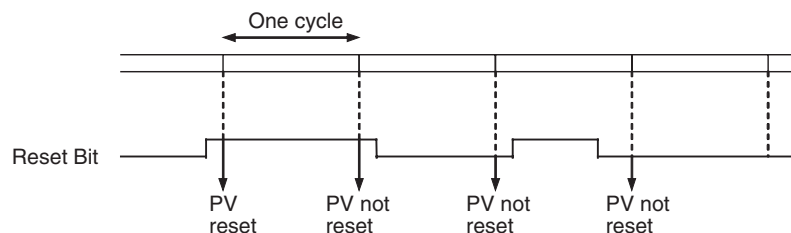

Note With CJ1M CPU Unit Ver. 2.0, the comparison operation can be set to stop or continue when a high-speed counter is reset. This enables applications where the comparison operation can be restarted from a counter PV of 0 when the counter is reset.

Setting the Reset Method

The reset is set under *Reset* in the *High-speed Counter 0/1 Area* on the *Built-in Input Tab Page* of the *PLC Setup*.

Using the CX-Programmer

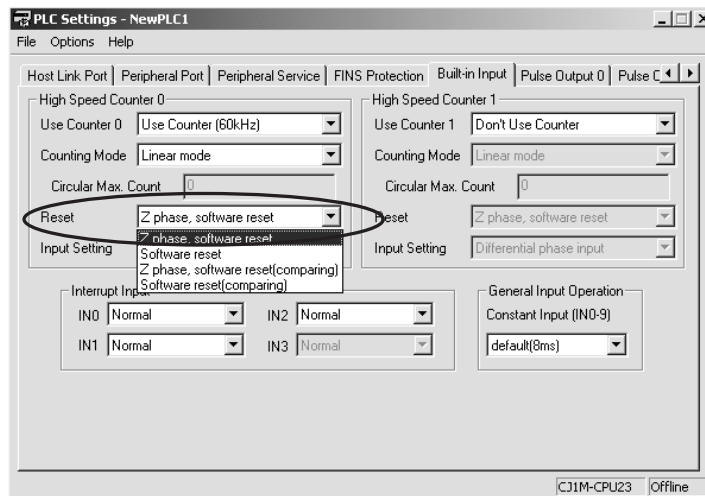

Refer to *High-speed Counter 0 Reset Method* on page 53 and *High-speed Counter 1 Reset Method* on page 55 for details on this parameter and the *Programming Console* setting address.

Starting Interrupt Tasks at Desired Counter PVs

Data registered in advance in a comparison table can be compared with the actual counter PVs during operation. The specified interrupt tasks (registered in the table) will be started when the corresponding comparison condition is met.

There are two comparison methods available: Target value comparison and range comparison.

- Use the CTBL(882) instruction to register the comparison table.
- Use either the CTBL(882) instruction or INI(880) instruction to start the comparison operation.
- Use either the INI(880) instruction to stop the comparison operation.

Target Value Comparison

The specified interrupt task is executed when the high-speed counter PV matches a target value registered in the table.

- The comparison conditions (target values and counting directions) are registered in the comparison table along with the corresponding interrupt task number. The specified interrupt task will be executed when the high-speed counter PV matches the registered target value.
- Up to 48 target values (between 1 and 48) can be registered in the comparison table.
- A different interrupt task can be registered for each target value.
- The target value comparison is performed on all of the target values in the table, regardless of the order in which the target values are registered.

- If the PV is changed, the changed PV will be compared with the target values in the table, even if the PV is changed while the target value comparison operation is in progress.

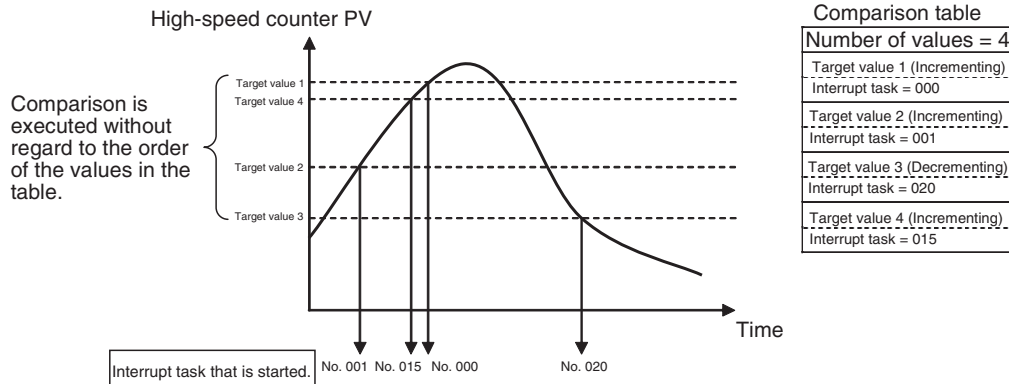

Restrictions

A comparison condition (target value and count direction) cannot appear in the table more than once. An error will occur if a comparison condition is specified two or more times.

Note When the count direction (incrementing/decrementing) changes at a PV that matches a target value, the next target value cannot be matched in that direction. Set the target values so that they do not occur at the peak or trough of count value changes.

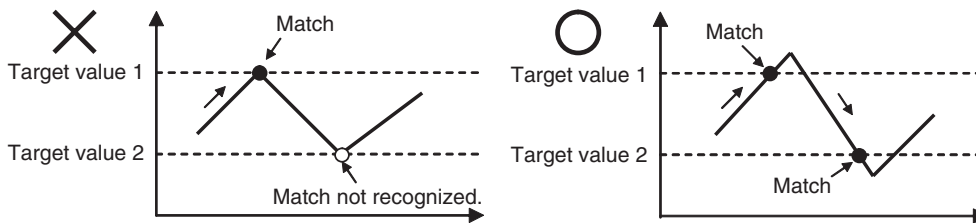

Range Comparison

The specified interrupt task is executed when the high-speed counter PV is within the range defined by the upper and lower limit values.

- The comparison conditions (upper and lower limits of the range) are registered in the comparison table along with the corresponding interrupt task number. The specified interrupt task will be executed once when the high-speed counter PV is in the range (Lower limit ≤ PV ≤ Upper limit).
- A total of 8 ranges (upper and lower limits) are registered in the comparison table.
- The ranges can overlap.
- A different interrupt task can be registered for each range.
- The counter PV is compared with the 8 ranges once each cycle.
- The interrupt task is executed just once when the comparison condition goes from unmet to met.

Restrictions

When more than one comparison condition is met in a cycle, the first interrupt task in the table will be executed in that cycle. The next interrupt task in the table will be executed in the next cycle.

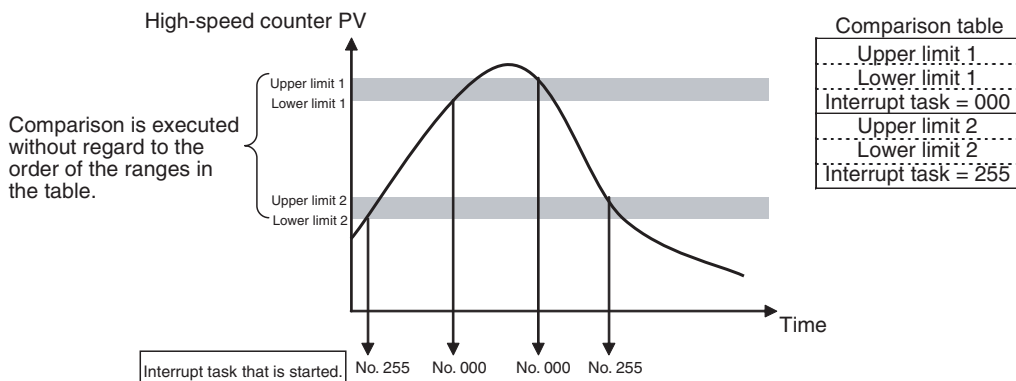

Note The range comparison table can be used without starting an interrupt task when the comparison condition is met. The range comparison function can be useful when you just want to know whether or not the high-speed counter PV is within a particular range. Use the Range Comparison Condition Met Flags (A27400 to A27407 and A27500 to A27507) to determine whether the high-speed counter PV is within a registered range.

Temporarily Stopping Input Signal Counting (Gate Function)

If the High-speed Counter Gate Bit is turned ON, the high-speed counter will not count even if pulse inputs are received and the counter PV will be maintained at its current value. The High-speed Counter 0 Gate Bit is A53102 and the High-speed Counter 1 Gate Bit is A53103.

When the High-speed Counter Gate Bit is turned OFF again, the high-speed counter will resume counting and the counter PV will be refreshed.

Restrictions

- The Gate Bit will be disabled if the high-speed counter's reset method is set to Phase-Z signal + Software reset and the Reset Bit is ON (waiting for the phase-Z input to reset the counter PV.)

High-speed Counter Frequency Measurement

This function measures the frequency of the high-speed counter (input pulses.)

The input pulse frequency can be read by executing the PRV(881) instruction. The measured frequency is output in 8-digit hexadecimal and expressed in Hz. The frequency measurement function can be used with high-speed counter 0 only.

The frequency can be measured while a high-speed counter 0 comparison operation is in progress. Frequency measurement can be performed at the same time as functions such as the high-speed counter and pulse output without affecting the performance of those functions.

Procedure

- 1,2,3... 1. High-speed Counter Enable/Disable Setting (Required)
Set the High-speed Counter 0 Enable/Disable setting to 1 or 2 (use high-speed counter) in the PLC Setup.

2. Pulse Input Mode Setting (Required)
Set the High-speed Counter 0 Pulse Input Mode in the PLC Setup.
3. Counting Mode Setting (Required)
Set the High-speed Counter 0 Counting Mode in the PLC Setup.
If ring mode counting is selected, set the High-speed Counter 0 Ring Counter Maximum Value (max. ring count) in the PLC Setup.
4. Reset Method Setting (Required)
Set the High-speed Counter 0 Reset Method in the PLC Setup.
5. PRV(881) Instruction Execution (Required)
N: Specify the high-speed counter number. (High-speed counter 0: #0010)
C: #0003 (Read frequency)
D: Destination word for frequency data

Restrictions

- The frequency measurement function can be used with high-speed counter 0 only.

Specifications

Item	Specifications
Number of frequency measurement inputs	1 input (high-speed counter 0 only)
Frequency measurement range	Differential phase inputs: 0 to 50 kHz All other input modes: 0 to 100 kHz Note If the frequency exceeds the maximum value, the maximum value will be stored.
Measurement method	Execution of the PRV(881) instruction
Output data range	Units: Hz Range: Differential phase input: 0000 0000 to 0003 0D40 hex All other input modes: 0000 0000 to 0001 86A0 hex

Pulse Frequency Conversion

The pulse frequency input to high-speed counter 0 can be converted to a rotational speed (r/min) or the PV of the counter can be converted to the total number of rotations. The converted value is output as 8-digit hexadecimal. This function is supported only for high-speed counter 0.

Frequency–Rotational Speed Conversion

The rotational speed in r/min is calculated from the pulse frequency input to high-speed counter 0 and the number of pulses per rotation.

Counter PV–Total Number of Rotations Conversion

The total number of rotations is calculated from the present value of the counter and the number of pulses per rotation.

Procedure

- 1,2,3...**
1. High-speed Counter Enable/Disable Setting (Required)
Set the High-speed Counter 0 Enable/Disable setting to 1 or 2 (use high-speed counter) in the PLC Setup.
 2. Pulse Input Mode Setting (Required)
Set the High-speed Counter 0 Pulse Input Mode in the PLC Setup.
 3. Counting Mode Setting (Required)
Set the High-speed Counter 0 Counting Mode in the PLC Setup.
If ring mode counting is selected, set the High-speed Counter 0 Ring Counter Maximum Value (max. ring count) in the PLC Setup.

4. Reset Method Setting (Required)
Set the High-speed Counter 0 Reset Method in the PLC Setup.
5. Execute PRV2 as described below (required).

Converting the Frequency to a Rotational Speed

Execute PRV2 with the following operands.

C: Control data (Set to #0000 for frequency-rotational speed conversion.)

P: Pulses/rotation (hex)

D: First word for result

Converting the Counter PV to the Total Number of Rotations

Execute PRV2 with the following operands.

C: Control data (Set to #0001 for counter PV-total number of rotations conversion.)

P: Pulses/rotation (hex)

D: First word for result

Restrictions

Pulse frequency conversion is possible only for high-speed counter 0.

6-1-5 Quick-response Inputs

Overview

The quick-response inputs read pulses with an ON time shorter than the cycle time (as short as 30 μ s). Use the quick-response inputs to read signals such as inputs from a photomicrosensor.

Procedure

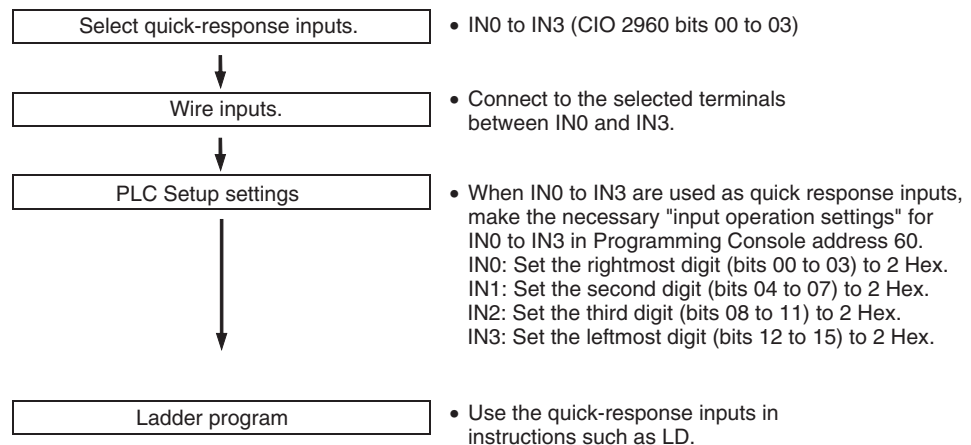

Restrictions on Quick-response Inputs

- Quick-response inputs 0 to 3 cannot be used when built-in inputs IN0 to IN3 are being used as general-purpose inputs or high-speed counter inputs.
- Quick-response input 3 cannot be used when high-speed counter input 0 is being used.
Quick-response input 2 cannot be used when high-speed counter input 1 is being used.
- Quick-response inputs 0 and 1 cannot be used when the origin search function is enabled for pulse output 0 (enabled in the PLC Setup).
Quick-response inputs 2 and 3 cannot be used when the origin search function is enabled for pulse output 1 (enabled in the PLC Setup).

Specifications

Item	Specifications
Number of quick-response inputs	4 inputs (The 4 input terminals are shared by the quick-response inputs, high-speed counters, and general-purpose inputs.)
Allocated data area	CIO 2960 bits 00 to 03
Minimum detectable pulse width	30 μs

6-1-6 Hardware Specifications

General Specifications

Item	Specifications
Number of inputs	10 inputs
Allocated data area	CIO 2960 bits 00 to 09
Input methods	24-V DC inputs or line-driver inputs
Response speed	ON response time Default setting: 8 ms max. (The input time constant can be set to 0 ms, 0.5 ms, 1 ms, 2 ms, 4 ms, 8 ms, 16 ms, or 32 ms in the PLC Setup.)
	OFF response time Default setting: 8 ms max. (The input time constant can be set to 0 ms, 0.5 ms, 1 ms, 2 ms, 4 ms, 8 ms, 16 ms, or 32 ms in the PLC Setup.)

Input Characteristics

Input voltage specifications	24 V DC		Line driver	
Terminals	IN0 to IN5	IN6 to IN9	IN0 to IN5	IN6 to IN9
Compatible sensors	Two-wire method	Two-wire method	Line driver	Line driver
Input voltage	24 V DC +10%, -15%		RS-422 line driver (conforming to AM26LS31 standards) (Power supply voltage of 5 V ±5%)	
Input impedance	3.6 kΩ	4.0 kΩ	---	---
Input current (typical)	6.0 mA	5.5 mA	13 mA	10 mA
ON voltage	17.4 V min.	17.4 V min.	---	---
OFF voltage	5.0 V/1 mA max.	5.0 V/1 mA max.	---	---

6-2 Built-in Outputs

6-2-1 Overview

There are 3 kinds of built-in outputs:

- General-purpose outputs
- Pulse outputs
- Variable duty ratio pulse outputs (PWM(891) outputs)

The built-in outputs are allocated bits 00 to 05 of CIO 2961. The Pulse Output Instructions must be executed to specify which kind of input is used for each bit.

6-2-2 General-purpose Outputs

Overview

This function is used to output standard output signals. The output point is refreshed when the allocated bit goes ON or OFF.

Bit Allocations

Code	Word address	Bit	Function
OUT0	CIO 2961	00	General-purpose output 0
OUT1		01	General-purpose output 1
OUT2		02	General-purpose output 2
OUT3		03	General-purpose output 3
OUT4		04	General-purpose output 4
OUT5		05	General-purpose output 5

Procedure

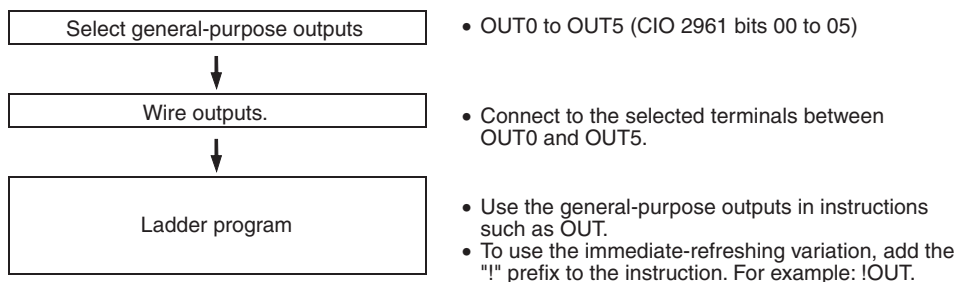

Note: Immediate refreshing cannot be performed by the IORF(097) instruction.

Restrictions on General-purpose Outputs

- General-purpose outputs 0 to 3 cannot be used if pulses are being output through those points by the pulse outputs.
- General-purpose outputs 4 and 5 cannot be used if variable duty ratio pulses (PWM(891) outputs) are being output through those points.
- General-purpose output 4 (5) cannot be used when the origin search function is enabled for pulse output 0 (1) and the Error Counter Reset Output is being used (origin search operating mode set to 1 or 2.)

Specifications

Item	Specifications
Number of outputs	6 outputs
Allocated data area	CIO 2961 bits 00 to 05

6-2-3 Pulse Outputs

Overview

The pulse output function outputs fixed duty ratio (duty ratio: 50%) pulse signals from the built-in output terminals.

Both speed control (outputting pulses continuously at specified frequencies) and positioning (outputting a specified number of pulses) are supported.

The pulse output functions are controlled by executing Pulse Output Instructions from the ladder program. In some cases, the instructions require PLC Setup settings to be made in advance.

The following table shows the instructions that can perform position control and speed control.

Instruction name	Mnemonic	Function code	Primary use
SET PULSES	PULS	886	Setting the number of pulses for pulse output
SPEED OUTPUT	SPED	885	Pulse output without acceleration or deceleration.
ACCELERATION CONTROL	ACC	888	Pulse output with acceleration and deceleration
PULSE OUTPUT	PLS2	887	Trapezoidal control
ORIGIN SEARCH	ORG	889	Origin search and origin return
MODE CONTROL	INI	880	Stopping pulse output or changing PVs
HIGH-SPEED COUNTER PV READ	PRV	881	Reading PVs

The CJ1M CPU Unit's pulse output functions have some features that are different from the earlier CPU Unit models. The differences are listed below.

- The target position can be changed during positioning (multiple start function). When a PLS2(887) instruction is being executed, another PLS2(887) instruction can be executed with a different target position.
- Operation can be switched from continuous speed control at a certain target frequency to positioning with a specified number of pulses to move a certain distance. When an ACC(888) instruction (continuous mode) is being executed, a PLS2(887) instruction can be executed to switch to positioning.
- When positioning by specifying absolute pulses, the CW/CCW direction can be selected automatically. The pulse output's CW/CCW direction will be selected automatically (based on the specified number of pulses and the pulse output PV) when a pulse output operation is executed with SPED(885), ACC(888), or PLS2(887) under the following conditions:
 1. The origin location has been determined by performing an origin search or setting the pulse output PV with INI(880).
 2. The absolute number of pulses is specified with PULS(886) or PLS2(887).

Bit Allocations

Code	Word address	Bit	CW/CCW inputs	Pulse + direction inputs
OUT0	CIO 2961	00	Pulse output 0 (CW)	Pulse output 0 (pulse)
OUT1		01	Pulse output 0 (CCW)	Pulse output 1 (pulse)
OUT2		02	Pulse output 1 (CW)	Pulse output 0 (direction)
OUT3		03	Pulse output 1 (CCW)	Pulse output 1 (direction)

Pulse Output Specifications

Item	Specifications
Output mode	Continuous mode (for speed control) or independent mode (for position control)
Positioning (independent mode) instructions	PULS(886) and SPED(885), PULS(886) and ACC(888), or PLS2(887)
Speed control (continuous mode) instructions	SPED(885) or ACC(888)
Origin (origin search and origin return) instructions	ORG(889)
Output frequency	1 Hz to 100 kHz (1 Hz units)
Acceleration and deceleration rates	Set in 1 Hz units for acceleration/deceleration rates from 1 Hz to 2 kHz (every 4 ms). The acceleration and deceleration rates can be set independently only with PLS2(887).
Changing SVs during instruction execution	The target frequency, acceleration/deceleration rate, and target position can be changed.
Duty ratio	Fixed at 50%
Pulse output method	CW/CCW inputs or Pulse + direction inputs The method is selected with an instruction operand. The same method must be used for pulse outputs 0 and 1.
Number of output pulses	Relative coordinates: 00000000 to 7FFFFFFF hex (Each direction accelerating or decelerating: 2,147,483,647) Absolute coordinates: 80000000 to 7FFFFFFF hex (-2147483648 to 2147483647)
Pulse output PV's relative/absolute coordinate specification	Absolute coordinates are specified automatically when the origin location has been determined by setting the pulse output PV with INI(880) or performing an origin search with ORG(889). Relative coordinates are used when the origin location is undetermined.
Relative pulse specification/Absolute pulse specification	The pulse type can be specified with an operand in PULS(886) or PLS2(887). Note The absolute pulse specification can be used when absolute coordinates are specified for the pulse output PV, i.e. the origin location has been determined. The absolute pulse specification cannot be used when relative coordinates are specified, i.e. the origin location is undetermined. An instruction error will occur.
Pulse output PV's storage location	The following Auxiliary Area words contain the pulse output PVs: Pulse output 0: A277 (leftmost 4 digits) and A276 (rightmost 4 digits) Pulse output 1: A279 (leftmost 4 digits) and A278 (rightmost 4 digits) The PVs are refreshed during regular I/O refreshing.
Acceleration/deceleration curve specification	Trapezoidal or S-curve acceleration/deceleration

Instructions Used for Pulse Outputs

Use the following 8 instructions to control the pulse outputs.

The following table shows the kinds of pulse outputs controlled by each instruction.

Instruction	Function	Positioning (independent mode)			Speed control (continuous mode)		Origin search
		Pulse output without acceleration/deceleration	Pulse output with acceleration/deceleration		Pulse output without acceleration/deceleration	Pulse output with acceleration/deceleration	
			Trapezoidal, equal acceleration/deceleration rates	Trapezoidal, separate acceleration/deceleration rates			
PULS(886) SET PULSES	Sets the number of pulses to be output.	Used	---	---	---	---	---
SPED(885) SPEED OUTPUT	Performs pulse output control without acceleration or deceleration. (When positioning, the number of pulses must be set in advance with PULS(886).)	Used	---	---	Used	---	---
ACC(888) ACCELERATION CONTROL	Performs pulse output control with acceleration and deceleration. (When positioning, the number of pulses must be set in advance with PULS(886).)	---	Used	---	---	Used	---
PLS2(887) PULSE OUTPUT	Performs pulse output control with independent acceleration and deceleration rates. (Also sets the number of pulses.)	---	---	Used	---	---	---
ORG(889) ORIGIN SEARCH	Actually moves the motor with pulse outputs and determines the machine origin based on the Origin Proximity Input and Origin Input signals	---	---	---	---	---	Used
INI(880) MODE CONTROL	Stops the pulse output. Changes the pulse output PV. (This operation determines the origin location.)	Used	Used	Used	Used	Used	---
PRV(881) HIGH-SPEED COUNTER PV READ	Reads the pulse output PV.	Used	Used	Used	Used	Used	---

Pulse Output Modes

There are two pulse output modes, independent mode is used when the number of pulses has been set and continuous mode is used when the number of pulses has not been set.

Mode	Description
Independent mode	This mode is used for positioning. Operation stops automatically when the preset number of pulses has been output. It is also possible to stop the pulse output early with INI(880).
Continuous mode	This mode is used for speed control. The pulse output will continue until it is stopped by executing another instruction or switching the PLC to PROGRAM mode.

Pulse Output Patterns

The following tables show the kinds of pulse output operations that can be performed by combining various pulse output instructions.

Continuous Mode (Speed Control)

Starting a Pulse Output

Operation	Example application	Frequency changes	Description	Procedure	
				Instruction	Settings
Output with specified speed	Changing the speed (frequency) in one step	<p>Pulse frequency vs Time graph. The y-axis is labeled 'Pulse frequency' and the x-axis is 'Time'. A horizontal dashed line represents the 'Target frequency'. An arrow points to the start of this line, labeled 'Execution of SPED(885)'. The frequency is zero before and then jumps to the target frequency.</p>	Outputs pulses at a specified frequency.	SPED(885) (Continuous)	<ul style="list-style-type: none"> •Port “CW/CCW” or “Pulse + direction” •Continuous •Target frequency
Output with specified acceleration and speed	Accelerating the speed (frequency) at a fixed rate	<p>Pulse frequency vs Time graph. The y-axis is labeled 'Pulse frequency' and the x-axis is 'Time'. A horizontal dashed line represents the 'Target frequency'. An arrow points to the start of the linear increase, labeled 'Execution of ACC(888)'. The slope of the linear increase is labeled 'Acceleration/deceleration rate'.</p>	Outputs pulses and changes the frequency at a fixed rate.	ACC(888) (Continuous)	<ul style="list-style-type: none"> •Port “CW/CCW” or “Pulse + direction” •Continuous •Acceleration/deceleration rate •Target frequency

Changing Settings

Operation	Example application	Frequency changes	Description	Procedure	
				Instruction	Settings
Change speed in one step	Changing the speed during operation	<p>The graph shows pulse frequency on the y-axis and time on the x-axis. A horizontal line represents the present frequency. At a certain point, the frequency jumps vertically to a higher level representing the target frequency. An arrow points to this jump, labeled 'Execution of SPED(885)'.</p>	Changes the frequency (higher or lower) of the pulse output in one step.	SPED(885) (Continuous) ↓ SPED(885) (Continuous)	<ul style="list-style-type: none"> •Port •Continuous •Target frequency
Change speed smoothly	Changing the speed smoothly during operation	<p>The graph shows pulse frequency on the y-axis and time on the x-axis. A horizontal line represents the present frequency. It then rises linearly to a higher level representing the target frequency. The slope of this rise is labeled 'Acceleration/deceleration rate'. An arrow points to the start of this rise, labeled 'Execution of ACC(888)'.</p>	Changes the frequency from the present frequency at a fixed rate. The frequency can be accelerated or decelerated.	ACC(888) or SPED(885) (Continuous) ↓ ACC(888) (Continuous)	<ul style="list-style-type: none"> •Port •Continuous •Target frequency •Acceleration/deceleration rate
	Changing the speed in a polyline curve during operation	<p>The graph shows pulse frequency on the y-axis and time on the x-axis. A horizontal line represents the present frequency. It then rises in a curve to a higher level representing the target frequency. The curve is divided into three segments with different slopes, labeled 'Acceleration rate 1', 'Acceleration rate 2', and 'Acceleration rate n'. Three arrows point to the start of each segment, labeled 'Execution of ACC(888)'.</p>	Changes the acceleration or deceleration rate during acceleration or deceleration.	ACC(888) (Continuous) ↓ ACC(888) (Continuous)	<ul style="list-style-type: none"> •Port •Continuous •Target frequency •Acceleration/deceleration rate
Change direction	Not supported.				
Change pulse output method	Not supported.				

Stopping a Pulse Output

Operation	Example application	Frequency changes	Description	Procedure	
				Instruction	Settings
Stop pulse output	Immediate stop	<p>The graph shows pulse frequency on the y-axis and time on the x-axis. A horizontal line represents the present frequency. At a certain point, the frequency drops vertically to zero. An arrow points to this drop, labeled 'Execution of INI(880)'.</p>	Stops the pulse output immediately.	SPED(885) or ACC(888) (Continuous) ↓ INI(880)	<ul style="list-style-type: none"> •Port •Stop pulse output

Operation	Example application	Frequency changes	Description	Procedure	
				Instruction	Settings
Stop pulse output	Immediate stop	<p>Pulse frequency</p> <p>Present frequency</p> <p>Time</p> <p>Execution of SPED(885)</p>	Stops the pulse output immediately.	SPED(885) or ACC(888) (Continuous) ↓ SPED(885) (Continuous)	<ul style="list-style-type: none"> •Port •Continuous •Target frequency=0
Stop pulse output smoothly	Decelerate to a stop	<p>Pulse frequency</p> <p>Present frequency</p> <p>Acceleration/ deceleration rate (Rate set at the start of the operation.)</p> <p>Target frequency = 0</p> <p>Time</p> <p>Execution of ACC(888)</p>	Decelerates the pulse output to a stop. Note If ACC(888) started the operation, the original acceleration/ deceleration rate will remain in effect. If SPED(885) started the operation, the acceleration/ deceleration rate will be invalid and the pulse output will stop immediately.	SPED(885) or ACC(888) (Continuous) ↓ ACC(888) (Continuous)	<ul style="list-style-type: none"> •Port •Continuous •Target frequency=0

**Independent Mode
(Positioning)**

Starting a Pulse Output

Operation	Example application	Frequency changes	Description	Procedure	
				Instruction	Settings
Output with specified speed	Positioning without acceleration or deceleration	<p>Pulse frequency vs Time graph. The frequency rises to a 'Target frequency' and remains constant until 'Execution of SPED(885)'. It then outputs the specified number of pulses and stops.</p>	<p>Starts outputting pulses at the specified frequency and stops immediately when the specified number of pulses has been output.</p> <p>Note The target position (specified number of pulses) cannot be changed during positioning.</p>	PULS(886) ↓ SPED(885)	<ul style="list-style-type: none"> •Number of pulses •Relative or absolute pulse specification •Port •“CW/CCW” or “Pulse + direction” •Independent •Target frequency
Simple trapezoidal control	Positioning with trapezoidal acceleration and deceleration (Same rate used for acceleration and deceleration; no starting speed) The number of pulses cannot be changed during positioning.	<p>Pulse frequency vs Time graph. The frequency rises linearly to 'Target frequency' at 'Execution of ACC(888)'. It stays constant until the specified number of pulses is reached, then falls linearly to zero.</p>	<p>Accelerates and decelerates at the same fixed rate and stops immediately when the specified number of pulses has been output. (See note.)</p> <p>Note The target position (specified number of pulses) cannot be changed during positioning.</p>	PULS(886) ↓ ACC(888) (Independent)	<ul style="list-style-type: none"> •Number of pulses •Relative or absolute pulse specification •Port •“CW/CCW” or “Pulse + direction” •Independent •Acceleration and deceleration rate •Target frequency
Complex trapezoidal control	Positioning with trapezoidal acceleration and deceleration (Separate rates used for acceleration and deceleration; starting speed) The number of pulses cannot be changed during positioning.	<p>Pulse frequency vs Time graph. It shows 'Starting frequency', 'Acceleration rate', 'Deceleration rate', and 'Stop frequency'. The frequency rises to 'Target frequency' at 'Execution of PLS2(887)'. It then stays constant until 'Deceleration point', then falls to zero.</p>	<p>Accelerates and decelerates at a fixed rates. The pulse output is stopped when the specified number of pulses has been output. (See note.)</p> <p>Note The target position (specified number of pulses) can be changed during positioning.</p>	PLS2(887)	<ul style="list-style-type: none"> •Number of pulses •Relative or absolute pulse specification •Port •“CW/CCW” or “Pulse + direction” •Acceleration rate •Deceleration rate •Target frequency •Starting frequency

Note Triangular Control

If the specified number of pulses is less than the number required just to reach the target frequency and return to zero, the function will automatically reduce the acceleration/deceleration time and perform triangular control (acceleration and deceleration only.) An error will not occur.

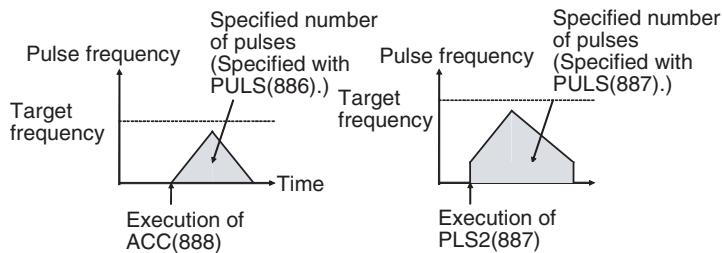

Changing Settings

Operation	Example application	Frequency changes	Description	Procedure	
				Instruction	Settings
Change speed in one step	Changing the speed in one step during operation	<p>Execution of SPED(885) (independent mode)</p> <p>SPED(885) (independent mode) executed again to change the target frequency. (The target position is not changed.)</p>	<p>SPED(885) can be executed during positioning to change (raise or lower) the pulse output frequency in one step.</p> <p>The target position (specified number of pulses) is not changed.</p>	<p>PULS(886) ↓ SPED(885) (Independent)</p> <p>↓ SPED(885) (Independent)</p>	<ul style="list-style-type: none"> •Number of pulses •Relative or absolute pulse specification •Port •“CW/CCW” or “Pulse + direction” •Independent •Target frequency
Change speed smoothly (with acceleration rate = deceleration rate)	Changing the target speed (frequency) during positioning (acceleration rate = deceleration rate)	<p>Execution of ACC(888) (independent mode)</p> <p>ACC(888) (independent mode) executed again to change the target frequency. (The target position is not changed, but the acceleration/deceleration rate is changed.)</p>	<p>ACC(888) can be executed during positioning to change the acceleration/deceleration rate and target frequency.</p> <p>The target position (specified number of pulses) is not changed.</p>	<p>PULS(886) ↓ ACC(888) or SPED(885) (Independent)</p> <p>↓ ACC(888) (Independent)</p> <p>PLS2(887) ↓ ACC(888) (Independent)</p>	<ul style="list-style-type: none"> •Number of pulses •Relative or absolute pulse specification •Port •“CW/CCW” or “Pulse + direction” •Independent •Acceleration and deceleration rate •Target frequency

Operation	Example application	Frequency changes	Description	Procedure	
				Instruction	Settings
Change speed smoothly (with unequal acceleration and deceleration rates)	Changing the target speed (frequency) during positioning (different acceleration and deceleration rates)		<p>PLS2(887) can be executed during positioning to change the acceleration rate, deceleration rate, and target frequency.</p> <p>Note To prevent the target position from being changed intentionally, the original target position must be specified in absolute coordinates.</p>	PULS(886) ↓ ACC(888) (Independent) ↓ PLS2(887) ↓ PLS2(887) ↓ PLS2(887)	<ul style="list-style-type: none"> •Number of pulses •Relative or absolute pulse specification •Port •“CW/CCW” or “Pulse + direction” •Acceleration rate •Deceleration rate •Target frequency •Starting frequency
Change target position	Change the target position during positioning (multiple start function)		<p>PLS2(887) can be executed during positioning to change the target position (number of pulses).</p> <p>Note When the target position cannot be changed without maintaining the same speed range, an error will occur and the original operation will continue to the original target position.</p>	PULS(886) ↓ ACC(888) (Independent) ↓ PLS2(887) ↓ PLS2(887) ↓ PLS2(887) ↓ PLS2(887)	<ul style="list-style-type: none"> •Number of pulses •Relative or absolute pulse specification •Port •“CW/CCW” or “Pulse + direction” •Acceleration rate •Deceleration rate •Target frequency •Starting frequency

Operation	Example application	Frequency changes	Description	Procedure	
				Instruction	Settings
Change target position and speed smoothly	Change the target position and target speed (frequency) during positioning (multiple start function)		<p>PLS2(887) can be executed during positioning to change the target position (number of pulses), acceleration rate, deceleration rate, and target frequency.</p> <p>Note When the settings cannot be changed without maintaining the same speed range, an error will occur and the original operation will continue to the original target position.</p>	PULS(886) ↓ ACC(888) (Independent) ↓ PLS2(887)	<ul style="list-style-type: none"> •Number of pulses •Relative or absolute pulse specification •Port •“CW/CCW” or “Pulse + direction” •Acceleration rate •Deceleration rate •Target frequency •Starting frequency
	Change the acceleration and deceleration rates during positioning (multiple start function)		<p>PLS2(887) can be executed during positioning (acceleration or deceleration) to change the acceleration rate or deceleration rate.</p>	PULS(886) ↓ ACC(888) (Independent) ↓ PLS2(887) ↓ PLS2(887)	<ul style="list-style-type: none"> •Number of pulses •Acceleration rate •Deceleration rate
Change direction	Change the direction during positioning		<p>PLS2(887) can be executed during positioning with relative pulse specification to change to absolute pulses and reverse direction.</p>	PULS(886) ↓ ACC(888) (Independent) ↓ PLS2(887) ↓ PLS2(887)	<ul style="list-style-type: none"> •Number of pulses •Absolute pulse specification •Port •“CW/CCW” or “Pulse + direction” •Acceleration rate •Deceleration rate •Target frequency •Starting frequency
Change pulse output method	Not supported.				

Stopping a Pulse Output

Operation	Example application	Frequency changes	Description	Procedure	
				Instruction	Settings
Stop pulse output (Number of pulses setting is not preserved.)	Immediate stop		Stops the pulse output immediately and clears the number of output pulses setting.	PULS(886) ↓ ACC(888) or SPED(885) (Independent) ↓ INI(880) PLS2(887) ↓ INI(880)	<ul style="list-style-type: none"> •Stop pulse output
Stop pulse output (Number of pulses setting is not preserved.)	Immediate stop		Stops the pulse output immediately and clears the number of output pulses setting.	PULS(886) ↓ SPED(885) (Independent) ↓ SPED(885)	<ul style="list-style-type: none"> •Port •Independent •Target frequency = 0
Stop pulse output smoothly. (Number of pulses setting is not preserved.)	Decelerate to a stop		Decelerates the pulse output to a stop. Note If ACC(888) started the operation, the original acceleration/ deceleration rate will remain in effect. If SPED(885) started the operation, the acceleration/ deceleration rate will be invalid and the pulse output will stop immediately.	PULS(886) ↓ ACC(888) or SPED(885) (Independent) ↓ ACC(888) (Independent) PLS2(887) ↓ ACC(888) (Independent)	<ul style="list-style-type: none"> •Port •Independent •Target frequency = 0

Switching from Continuous Mode (Speed Control) to Independent Mode (Positioning)

Example application	Frequency changes	Description	Procedure	
			Instruction	Settings
Change from speed control to fixed distance positioning during operation	<p>Outputs the number of pulses specified in PLS2(887) (Both relative and absolute pulse specification can be used.)</p> <p>Pulse frequency</p> <p>Target frequency</p> <p>Execution of ACC(888) (continuous)</p> <p>Execution of PLS2(887)</p> <p>Time</p>	<p>PLS2(887) can be executed during a speed control operation started with ACC(888) to change to positioning operation.</p> <p>Note An error will occur if a constant speed cannot be achieved after switching the mode. If this happens, the instruction execution will be ignored and the previous operation will be continued.</p>	<p>ACC(888) (Continuous) ↓ PLS2(887)</p>	<ul style="list-style-type: none"> •Port •Acceleration rate •Deceleration rate •Target frequency •Number of pulses <p>Note The starting frequency is ignored.</p>
Fixed distance feed interrupt	<p>Pulse frequency</p> <p>Present frequency</p> <p>Execution of ACC(888) (continuous)</p> <p>Execution of PLS2(887) with the following settings</p> <ul style="list-style-type: none"> • Number of pulses = number of pulses until stop • Relative pulse specification • Target frequency = present frequency • Acceleration rate = Not 0 • Deceleration rate = target deceleration rate <p>Time</p>			

Conditions Required to Execute an Instruction During Operation

The following table shows the pulse output instructions that can be executed while another pulse output instruction is being executed.

When positioning is being performed in independent mode, another independent mode instruction can be executed. When speed control is being performed in continuous mode, another continuous mode instruction can be executed. PLS2(887) is only instruction that can be used to switch between modes. (PLS2(887) can switch to a positioning operation from a continuous mode operation started with ACC(888).)

With the CJ1M CPU Unit, it is possible to execute a pulse control instruction during acceleration/deceleration or execute a positioning instruction to override another positioning instruction that is in progress.

Instruction being executed		Overriding instruction (Yes: Can be executed; No: Cannot be executed)						
		INI	SPED (Ind.)	SPED (Cont.)	ACC (Ind.)	ACC (Cont.)	PLS2	ORG
SPED(885) (Independent mode)		Yes	Yes ¹	No	Yes ³	No	No	No
SPED(885) (Continuous mode)		Yes	No	Yes ²	No	Yes ⁵	No	No
ACC(888) (Ind.)	Steady speed	Yes	No	No	Yes ⁴	No	Yes ⁶	No
	Accelerating or decelerating	Yes	No	No	Yes ⁴	No	Yes ⁶	No
ACC(888) (Cont.)	Steady speed	Yes	No	No	No	Yes ⁵	Yes ⁷	No
	Accelerating or decelerating	Yes	No	No	No	Yes ⁵	Yes ⁷	No
PLS2(887)	Steady speed	Yes	No	No	Yes ⁴	No	Yes ⁸	No
	Accelerating or decelerating	Yes	No	No	Yes ⁴	No	Yes ⁸	No
ORG(889)	Steady speed	Yes	No	No	No	No	No	No
	Accelerating or decelerating	Yes	No	No	No	No	No	No

- Note**
1. SPED(885) (Ind.) to SPED(885) (Ind.)
 - The number of output pulses cannot be changed.
 - The frequency can be changed.
 - The output mode and direction cannot be switched.
 2. SPED(885) (Cont.) to SPED(885) (Cont.)
 - The frequency can be changed.
 - The output mode and direction cannot be switched.
 3. SPED(885) (Ind.) to ACC(888) (Ind.)
 - The number of output pulses cannot be changed.
 - The frequency can be changed.
 - The acceleration/deceleration rate can be changed.
 - The output mode and direction cannot be switched.
 4. ACC(888) (Ind.) to ACC(888) (Ind.) or PLS2(887) to ACC(888) (Ind.)
 - The number of output pulses cannot be changed.
 - The frequency can be changed.
 - The acceleration/deceleration rate can be changed (even during acceleration or deceleration.)
 - The output mode and direction cannot be switched.
 5. SPED(885) (Cont.) to ACC(888) (Cont.) or ACC(888) (Cont.) to ACC(888) (Cont.)
 - The frequency can be changed (even during acceleration or deceleration.)
 - The acceleration/deceleration rate can be changed (even during acceleration or deceleration.)
 - The output mode and direction cannot be switched.

- 6. ACC(888) (Ind.) to PLS2(887)
 - The number of output pulses can be changed (even during acceleration or deceleration.)
 - The frequency can be changed (even during acceleration or deceleration.)
 - The acceleration/deceleration rate can be changed (even during acceleration or deceleration.)
 - The output mode and direction cannot be switched.
- 7. ACC(888) (Cont.) to PLS2(887)
 - The frequency can be changed (even during acceleration or deceleration.)
 - The acceleration/deceleration rate can be changed (even during acceleration or deceleration.)
 - The output mode and direction cannot be switched.
- 8. PLS2(887) to PLS2(887)
 - The number of output pulses can be changed (even during acceleration or deceleration.)
 - The frequency can be changed (even during acceleration or deceleration.)
 - The acceleration/deceleration rate can be changed (even during acceleration or deceleration.)
 - The output mode and direction cannot be switched.

Relative Pulse Outputs and Absolute Pulse Outputs

Selecting Relative or Absolute Coordinates

The pulse output PV's coordinate system (absolute or relative) is selected automatically, as follows:

- When the origin is undetermined, the system operates in relative coordinates.
- When the origin has been determined, the system operates in absolute coordinates.

Conditions	Origin has been determined by an origin search	Origin has been determined by executing INI(880) to change the PV	Origin not established (Origin search has not been performed and PV has not been changed with INI(880).)
Pulse output PV's coordinate system	Absolute coordinates		Relative coordinates

Relationship between the Coordinate System and Pulse Specification

The following table shows the pulse output operation for the four possible combinations of the coordinate systems (absolute or relative) and the pulse specifications (absolute or relative) made when PULS(886) or PLS2(887) is executed.

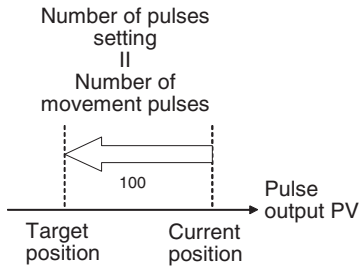
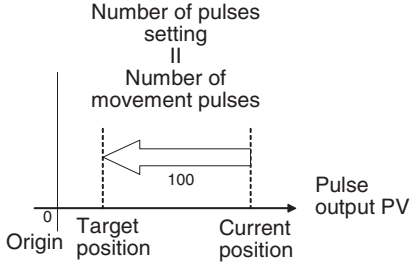
Coordinate system	Relative coordinate system	Absolute coordinate system
Path specification made with instruction (PULS(886) or PLS2(887))	<p>Origin not established:</p> <p>The Pulse Output 0 Origin Established Flag (A28005) or Pulse Output 1 Origin Established Flag (A28105) will be ON.</p>	<p>Origin established:</p> <p>The Pulse Output 0 Origin Established Flag (A28005) or Pulse Output 1 No-origin Flag (A28105) will be OFF.</p>
<p>Relative pulse specification</p>	<p>Positions the system to another position relative to the current position.</p> <p>Number of movement pulses = number of pulses setting</p> <p>The pulse output PV after instruction execution = Number of movement pulses = Number of pulses setting</p> <p>Note The pulse output PV is reset to 0 just before pulses are output. After that, the specified number of pulses is output.</p> <p>The following example shows the number of pulses setting = 100 counterclockwise.</p>  <p>Pulse output PV range: 80000000 to 7FFFFFFF hex</p> <p>Number of pulses setting range: 00000000 to 7FFFFFFF hex</p>	<p>The pulse output PV after instruction execution = PV + Number of movement pulses.</p> <p>The following example shows the number of pulses setting = 100 counterclockwise.</p>  <p>Pulse output PV range: 80000000 to 7FFFFFFF hex</p> <p>Number of pulses setting range: 00000000 to 7FFFFFFF hex</p>

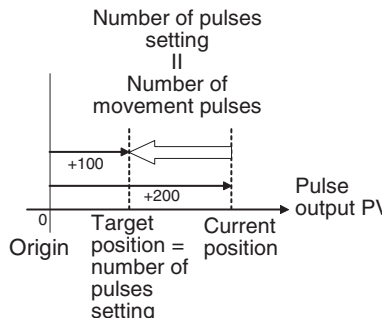
Coordinate system	Relative coordinate system	Absolute coordinate system
Path specification made with instruction (PULS(886) or PLS2(887))	Origin not established: The Pulse Output 0 Origin Established Flag (A28005) or Pulse Output 1 Origin Established Flag (A28105) will be ON.	Origin established: The Pulse Output 0 Origin Established Flag (A28005) or Pulse Output 1 No-origin Flag (A28105) will be OFF.
Absolute pulse specification	The absolute pulse specification cannot be used when the origin location is undetermined, i.e., when the system is operating in the relative coordinate system. An instruction execution error will occur.	<p>Positions the system to an absolute position relative to the origin.</p> <p>The number of movement pulses and movement direction are calculated automatically from the current position (pulse output PV) and target position.</p> <p>The following example shows the number of pulses setting = +100.</p>  <p>Number of movement pulses = Number of pulses setting - Pulse output PV when instruction is executed</p> <p>The movement direction is determined automatically.</p> <p>Pulse output PV range: 80000000 to 7FFFFFFF hex</p> <p>Number of pulses setting range: 80000000 to 7FFFFFFF hex</p>

Operations Affecting the Origin Status

The following table shows the operations that can affect the origin status, such as changing the operating mode and executing certain instructions.

The Pulse Output 0 No-origin Flag (A28005) and Pulse Output 1 No-origin Flag (A28105) indicate whether the origin location is undetermined for the corresponding pulse output. The flag will be ON when the corresponding pulse output's origin is undetermined.

Current status		PROGRAM mode		RUN mode or MONITOR mode	
Operation		Origin established	Origin not established	Origin established	Origin not established
Operating mode change	Switch to RUN or MONITOR	Status changes to "Origin not established."	"Origin not established" status continues.	---	---
	Switch to PROGRAM	---	---	"Origin established" status continues.	"Origin not established" status continues.

Current status Operation		PROGRAM mode		RUN mode or MONITOR mode	
		Origin established	Origin not established	Origin established	Origin not established
Instruction execution	Origin search performed by ORG(889)	---	---	Status changes to "Origin established."	Status changes to "Origin established."
	PV changed by INI(880)	---	---	"Origin established" status continues.	Status changes to "Origin established."
The Pulse Output Reset Bit (A54000 or A54100) goes from OFF to ON.		Status changes to "Origin not established."	"Origin not established" status continues.	Status changes to "Origin not established."	"Origin not established" status continues.

Movement Direction when Using Absolute Pulse Specification

When operating with the absolute pulse specification, the movement direction is selected automatically based on the relationship between the pulse output PV when the instruction is executed and the specified target position. The direction (CW/CCW) specified in an ACC(888) or SPED(885) instruction is not effective.

Procedure

Single-phase Pulse Output without Acceleration/Deceleration

The number of output pulses setting cannot be changed during positioning.

■ PULS(886) and SPED(885)

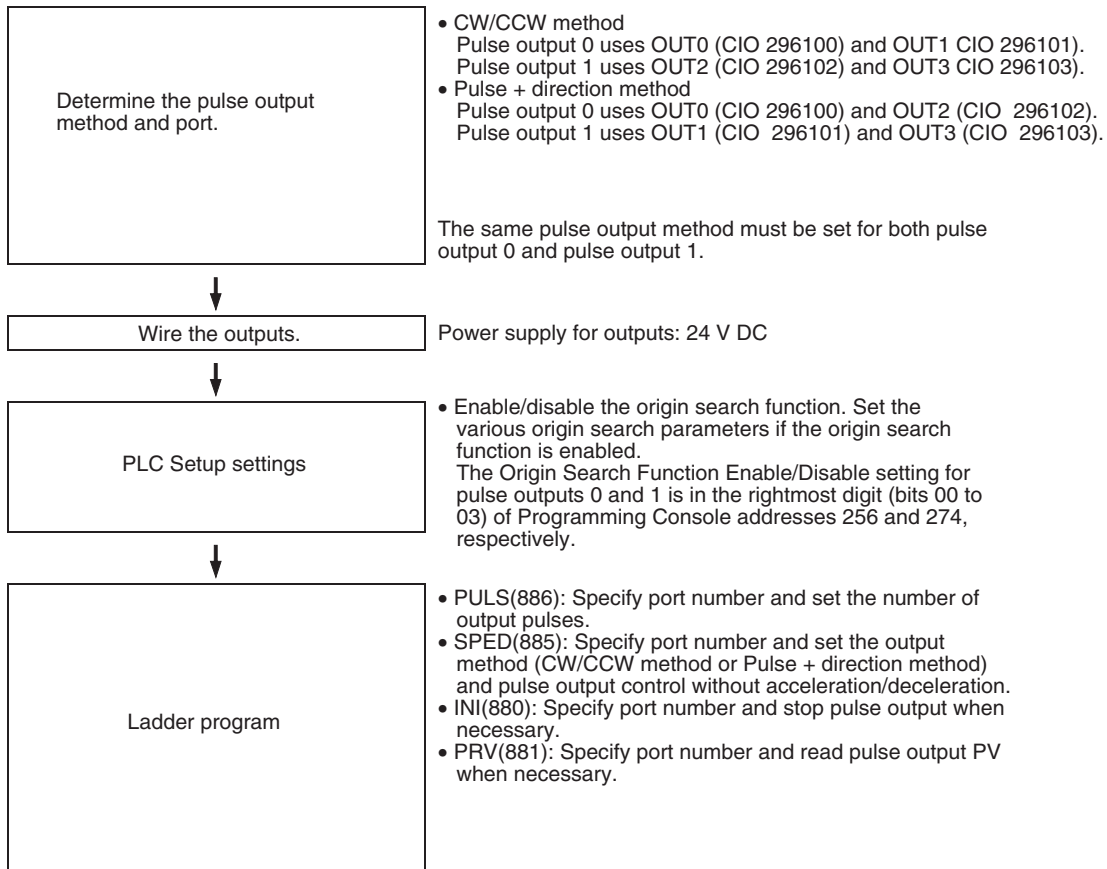

Single-phase Pulse Output with Acceleration/Deceleration

■ PULS(886) and ACC(888)

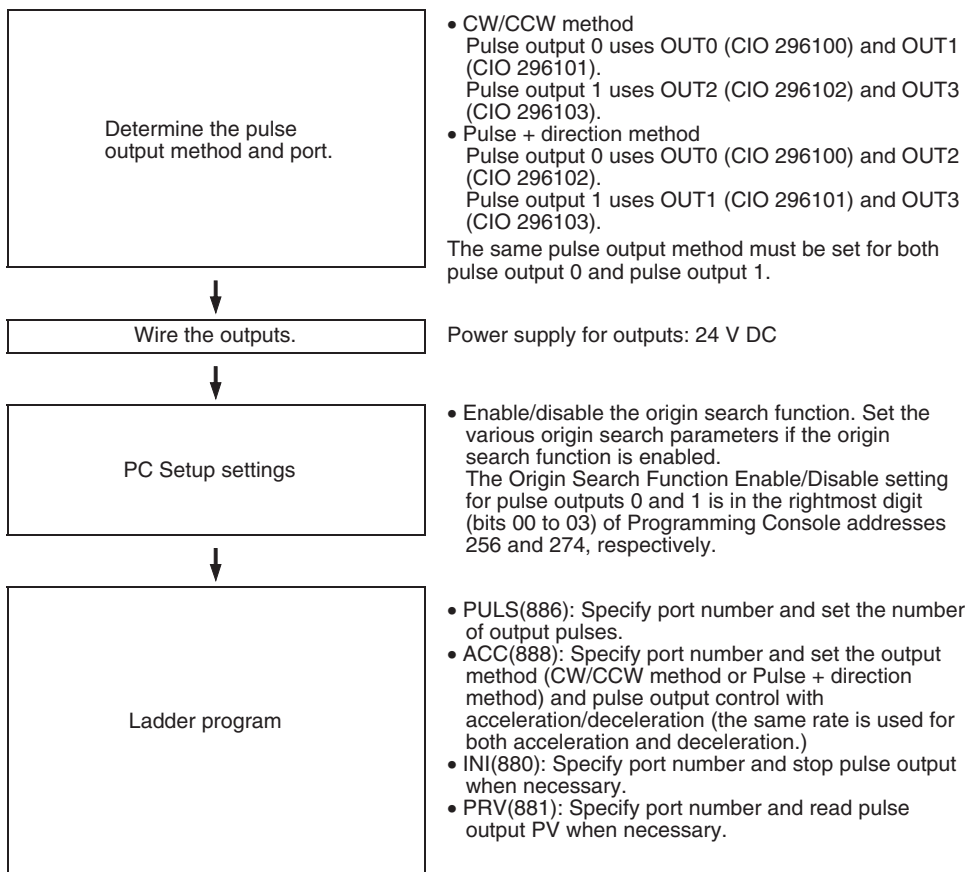

Pulse Output with Trapezoidal Acceleration/Deceleration (Using PLS2(887))

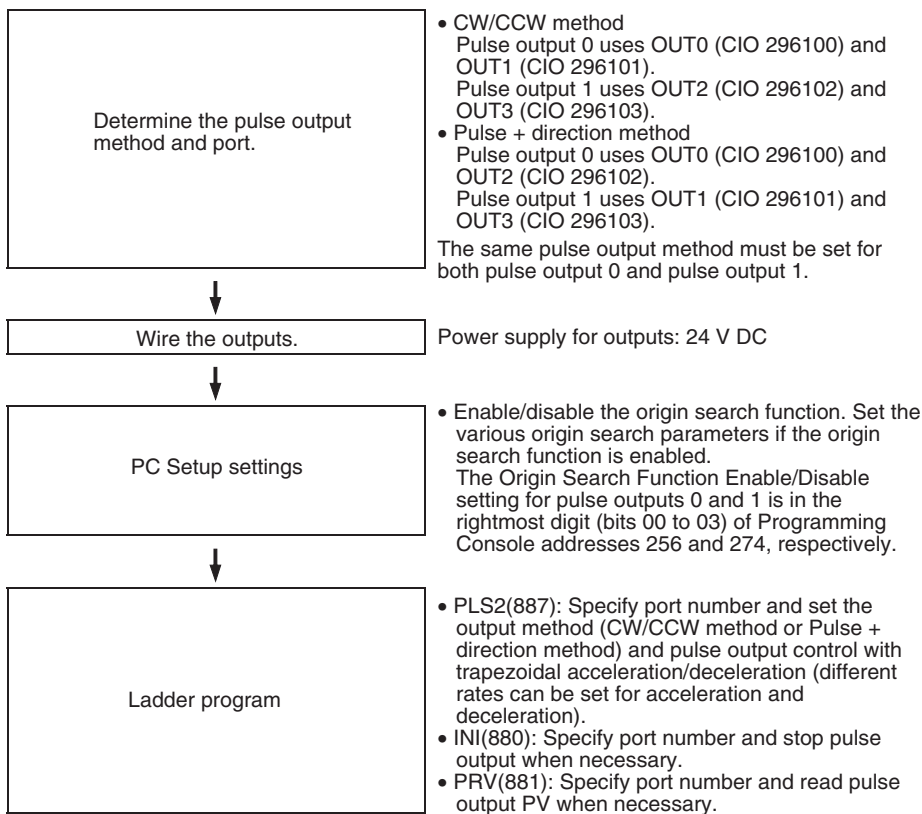

Using CW/CCW Limit Inputs for Pulse Output Functions Other than Origin Searches (CJ1M CPU Unit Ver. 2.0 Only)

Pulse outputs will stop when either of the CW/CCW limit input signals (A54008, A54009, A54108, and A54109) turns ON. With the previous version of the CJ1M CPU Units, the CW/CCW limit input signals could be used only with origin searches. With the CJ1M CPU Unit Ver. 2.0, these signals can be used with other pulse output functions. It is also possible to set whether to undefine the origin when a CW/CCW limit input signal turns ON for an origin search or other pulse output function.

Procedure

- 1,2,3...**
1. Specify in the following PLC Setup settings whether to use the CW/CCW limit input signals (A54008, A54009, A54108, and A54109) only for origin searches or for all pulse output functions.

Pulse Output 0 Limit Input Signal Operation (CJ1M CPU Unit Ver. 2.0 Only)

Programming Console setting address		Settings	Default	Function	Related Auxiliary Area flags/bits	Time when setting is read by CPU Unit
Word	Bits					
256	04 to 07	0 hex: Search only 1 hex: Always	0 hex	Specifies whether to use the CW/CCW limit input signals (reflected in A54008, A54009, A54108, and A54109) only for origin searches or for all pulse output functions.	---	When power is turned ON

**Pulse Output 1 Limit Input Signal Operation
(CJ1M CPU Unit Ver. 2.0 Only)**

Programming Console setting address		Settings	Default	Function	Related Auxiliary Area flags/ bits	Time when setting is read by CPU Unit
Word	Bits					
274	04 to 07	0 hex: Search only 1 hex: Always	0 hex	Specifies whether to use the CW/CCW limit input signals (reflected in A54008, A54009, A54108, and A54109) only for origin searches or for all pulse output functions.	---	When power is turned ON

- Specify in the following PLC Setup settings whether to undefine the origin when a CW/CCW limit input signal turns ON.

Pulse Output 0 Undefine Origin Setting (CJ1M CPU Unit Ver. 2.0 Only)

Programming Console setting address		Settings	Default	Function	Related Auxiliary Area flags/ bits	Time when setting is read by CPU Unit
Word	Bits					
268	12 to 15	0 hex: Hold 1 hex: Undefine	0 hex	Specifies whether to hold the origin setting when the CW/CCW limit input signal is input during execution of an origin search or pulse output function.	---	When operation starts

Pulse Output 1 Undefine Origin Setting (CJ1M CPU Unit Ver. 2.0 Only)

Programming Console setting address		Settings	Default	Function	Related Auxiliary Area flags/ bits	Time when setting is read by CPU Unit
Word	Bits					
286	12 to 15	0 hex: Hold 1 hex: Undefine	0 hex	Specifies whether to hold the origin setting when the CW/CCW limit input signal is input during execution of an origin search or pulse output function.	---	When operation starts

S-curve Acceleration/Deceleration

S-curve acceleration/deceleration can be used for pulse output instructions involving acceleration/deceleration. When there is leeway in the maximum allowable speed, S-curve accelerations/decelerations will help control shock and vibration by reducing the initial acceleration rate in comparison with linear acceleration/deceleration.

Note The setting for S-curve acceleration/deceleration applies to all pulse outputs.

Output Pattern

The output pattern for S-curve acceleration/deceleration is shown below.

Example for PLS2(887)

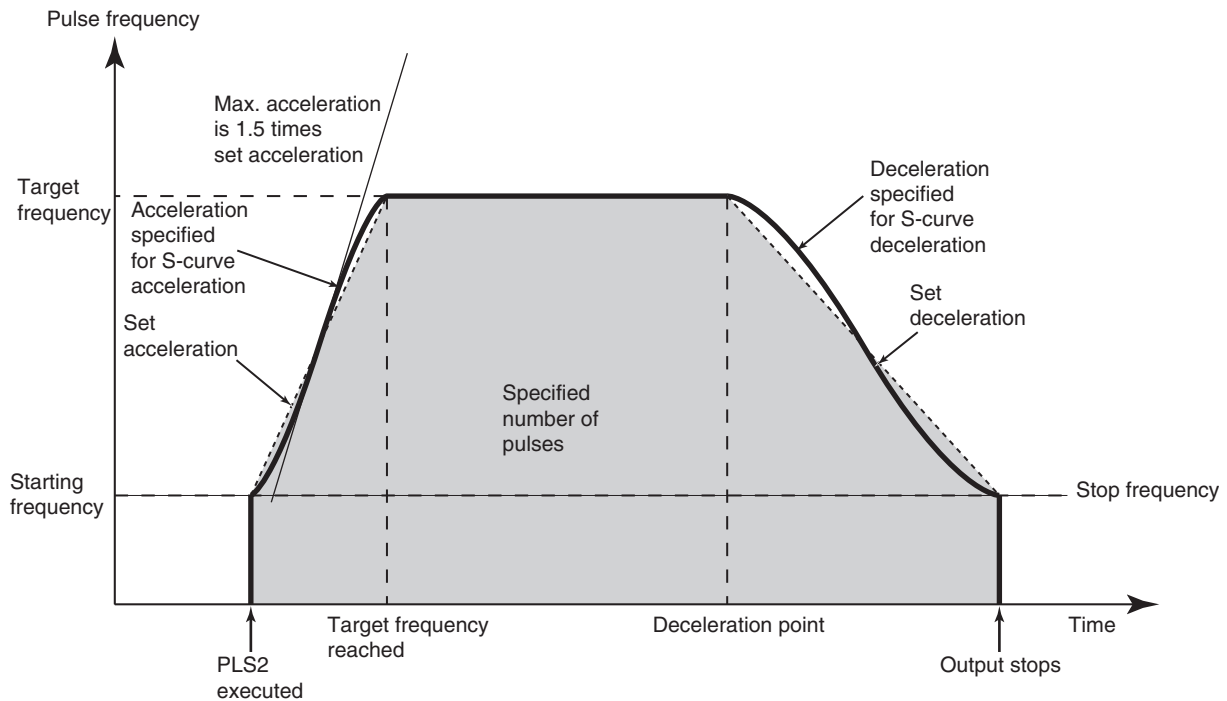

The same type of S-curve acceleration/deceleration can be used for ACC(888) as well.

Note The curve for S-curve acceleration/deceleration is formed by applying a tertiary function to the straight line of the set acceleration/deceleration rates (a tertiary polynomial approximation). The maximum acceleration will be 1.5 times that of trapezoidal acceleration/deceleration for the same acceleration/deceleration rate.

Procedure

Make the following settings in the PLC Setup.

Pulse Output 0 Speed Curve (CJ1M CPU Unit Ver. 2.0 Only)

Programming Console setting address		Settings	Default	Function	Related Auxiliary Area flags/bits	Time when setting is read by CPU Unit
Word	Bits					
256	12 to 15	0 hex: Trapezium (linear) 1 hex: S-shaped	0 hex	Specifies whether to use S-curve or linear acceleration/deceleration rates for pulse outputs with acceleration/deceleration.	---	When power is turned ON

Pulse Output 1 Speed Curve (CJ1M CPU Unit Ver. 2.0 Only)

Programming Console setting address		Settings	Default	Function	Related Auxiliary Area flags/bits	Time when setting is read by CPU Unit
Word	Bits					
274	12 to 15	0 hex: Trapezium (linear) 1 hex: S-shaped	0 hex	Specifies whether to use S-curve or linear acceleration/deceleration rates for pulse outputs with acceleration/deceleration.	---	When power is turned ON

Restrictions

The following restrictions apply when using S-curve acceleration/deceleration.

Starting Frequency

The starting frequency must be 100 Hz or greater. If the starting frequency is set to less than 100 Hz, it will automatically be increased to 100 Hz if S-curve acceleration/deceleration is set.

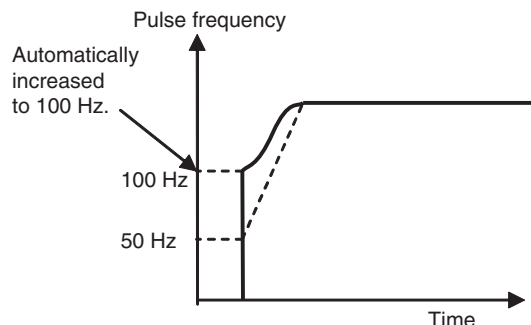

Target Frequency

S-curve acceleration/deceleration will not be performed if the target frequency is less than 100 Hz.

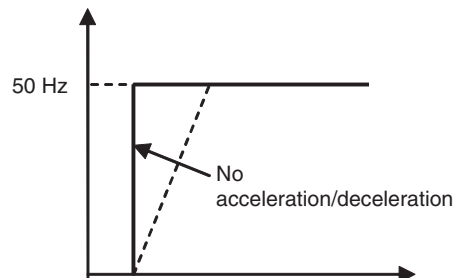

6-2-4 Variable Duty Ratio Pulse Outputs (PWM(891) Outputs)

Overview

The PWM(891) instruction is used to generate PWM(891) (Pulse Width Modulation) pulse outputs with a specified duty ratio. The duty ratio is the ratio of the pulse's ON time and OFF time in one pulse cycle. The duty ratio can be changed while pulses are being output.

Bit Allocations

Code	Word address	Bit	Function
OUT4	CIO 2961	04	PWM(891) output 0
OUT5		05	PWM(891) output 1

Procedure

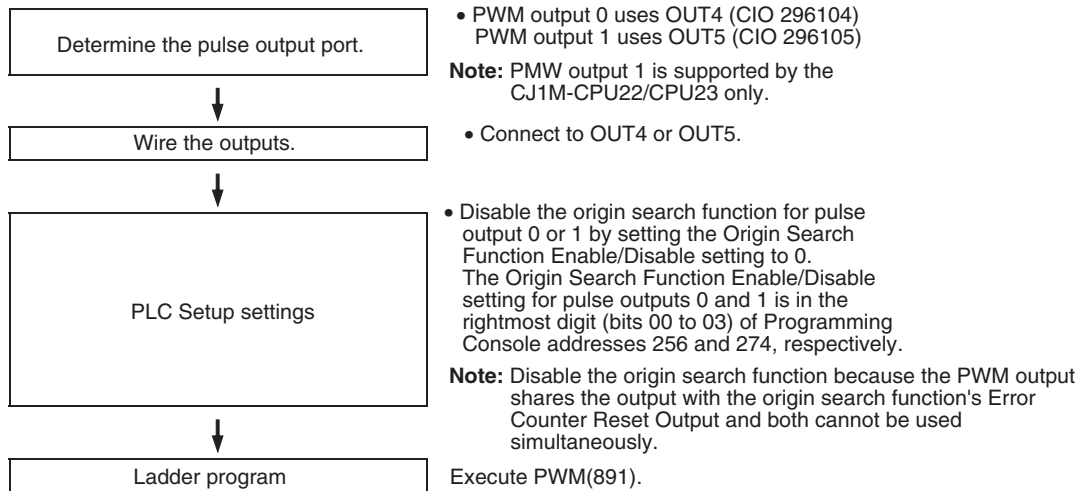

Restrictions on the PWM(891) Outputs

- Pulse outputs 0 and 1 cannot be used for PWM(891) outputs 0 and 1 if the origin search function is enabled for the pulse output.

Specifications

Item	Specifications
Duty ratio	CJ1M Pre-Ver. 2.0 CPU Units: 0% to 100% in 1% increments CJ1M CPU Units Ver. 2.0: 0.0% to 100.0% in 0.1% increments (Duty ratio accuracy is ±5% at 1 kHz.)
Frequency	0.1 Hz to 6,553.5 Hz Set in 0.1 Hz units. (See note.)
Output mode	Continuous mode
Instruction	PWM(891)

Note The frequency can be set up to 6553.5 Hz in the PWM(891) instruction, but the duty ratio accuracy declines significantly at frequencies over 1 kHz because of limitations in the output circuit at high frequencies.

6-3 Origin Search and Origin Return Functions

6-3-1 Overview

The CJ1M CPU Units have two functions that can be used to determine the machine origin for positioning.

- 1,2,3...**
1. Origin Search
The origin search function outputs pulses to turn the motor according to the pattern specified in the origin search parameters. As the motor turns, the origin search function determines the machine origin from the following 3 kinds of position information.
 - Origin input signal
 - Origin proximity input signal
 - CW limit input signal and CCW limit input signal
 2. Changing the Pulse Output PV
When you want to set the current position as the origin, execute INI(880) to reset the pulse output PV to 0.

The origin location can be determined after using either method.

The CJ1M CPU Units are also equipped with the origin return function, which can be executed to return the system to the origin after the origin location has been determined by one of the methods above.

- Origin Return
If the motor is stopped, ORG(889) can be executed to perform an origin return operation that moves the motor back to the origin position. The origin position must be determined in advance by performing an origin search or changing the pulse output PV.

Note The motor can be moved even if the origin position has not been determined, but positioning operations will be limited as follows:

- Origin return: Cannot be used.
- Positioning with absolute pulse specification: Cannot be used.
- Positioning with relative pulse specification: Outputs the specified number of pulses after setting the current position to 0.

6-3-2 Origin Search

Overview

When ORG(889) executes an origin search, it outputs pulses to actually move the motor and determines the origin position using the input signals that indicate the origin proximity and origin positions.

The input signals that indicate the origin position can be received from the servomotor's built-in phase-Z signal or external sensors such as photoelectric sensors, proximity sensors, or limit switches.

Several origin search patterns can be selected.

In the following example, the motor is started at a specified speed, accelerated to the origin search high speed, and run at that speed until the origin proximity position is detected. After the Origin Proximity Input is detected, the

motor is decelerated to the origin search low speed and run at that speed until the origin position is detected. The motor is stopped at the origin position.

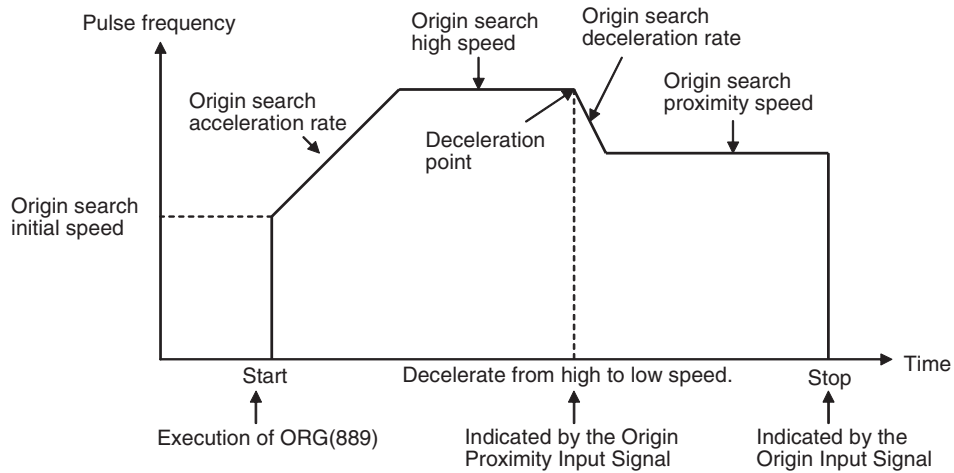

Bit Allocations

Origin Search for Pulse Output 0

Code	Word address	Bit	CW/CCW inputs	Pulse + direction inputs	Bits used when origin search function is enabled.
OUT0	CIO 2961	00	Pulse output 0 (CW)	Pulse output 0 (pulse)	
OUT1		01	Pulse output 0 (CCW)		
OUT2		02		Pulse output 0 (direction)	
OUT4		04			Origin search 0 (Error counter reset output)
IN0	2960	00			Origin search 0 (Origin Input Signal)
IN1		01			Origin search 0 (Origin Proximity Input Signal)
IN4		04			Origin search 0 (Positioning Completed Signal)

Origin Search for Pulse Output 1

Code	Word address	Bit	CW/CCW inputs	Pulse + direction inputs	Bits used when origin search function is enabled.
OUT1	CIO 2961	01		Pulse output 1 (pulse)	
OUT2		02	Pulse output 1 (CW)		
OUT3		03	Pulse output 1 (CCW)	Pulse output 1 (direction)	
OUT5		05			Origin search 1 (Error counter reset output)
IN2	2960	02			Origin search 1 (Origin Input Signal)
IN3		03			Origin search 1 (Origin Proximity Input Signal)
IN5		05			Origin search 1 (Positioning Completed Signal)

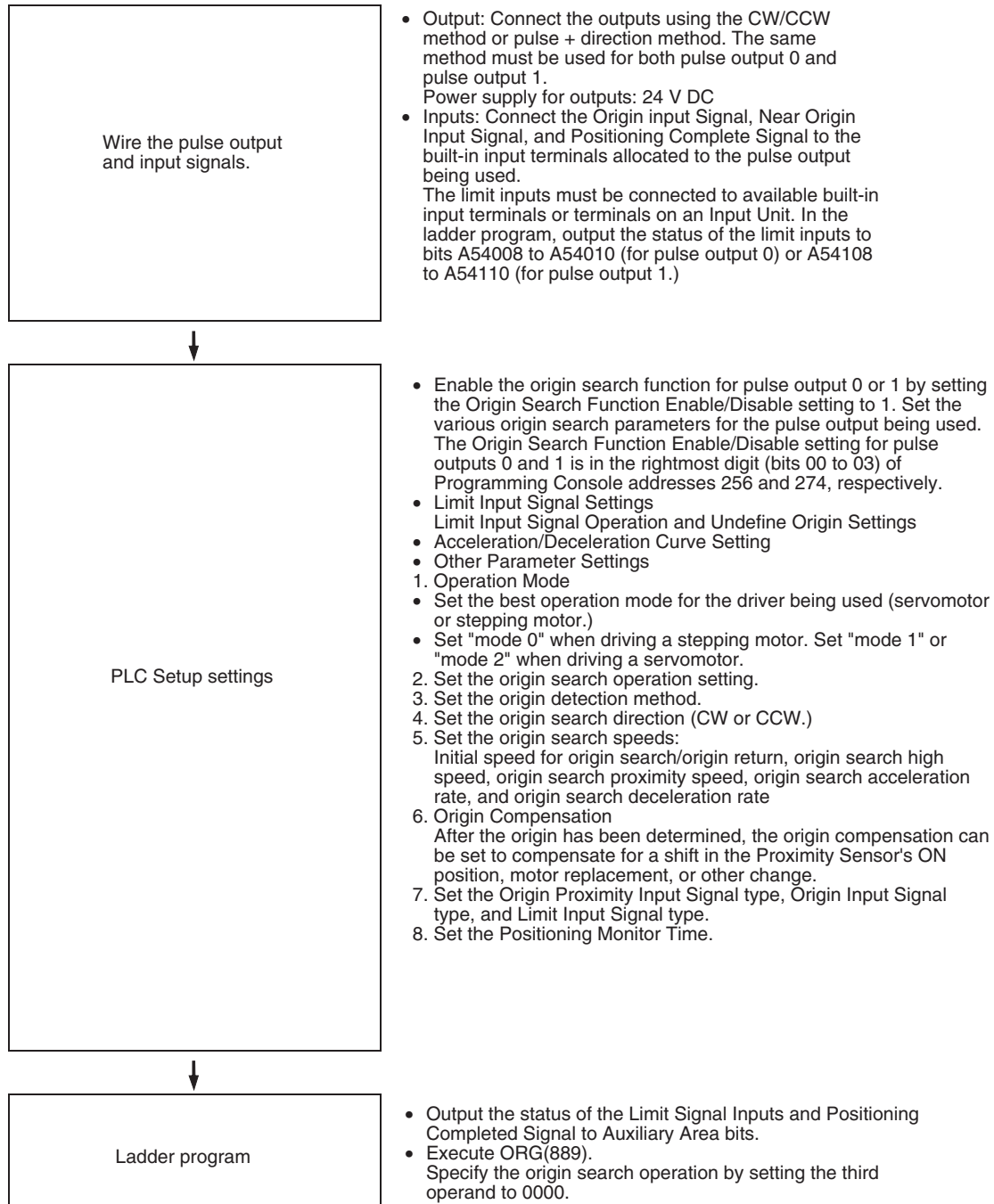
Procedure**Restrictions**

- The Phase-Z signal + Software reset method cannot be used for high-speed counters 0 and 1 when the origin search function for pulse output 1 has been enabled in the PLC Setup (with a setting of 1 hex in bits 00 to 03 of Programming Console address 274.)

PLC Setup Settings**Origin Search Function Enable/Disable Settings for Pulse Outputs 0 and 1**

These PLC Setup settings indicate whether or not the origin search function will be used for each pulse output.

Pulse Output 0 Use Origin Operation Settings (Origin Search Function Enable/Disable)

Programming Console setting address		Settings	Default	Function	Related Auxiliary Area flags/ bits	Time when setting is read by CPU Unit
Word	Bits					
256	00 to 03	0 hex: Disabled 1 hex: Enabled	0 hex	Specifies whether or not the origin search function is used for pulse output 0. Note Interrupt inputs 0 and 1 and PWM(891) output 0 cannot be used when the origin search function is enabled (setting 1) for pulse output 0. High-speed counters 0 and 1 can be used.	---	When power is turned ON

Pulse Output 1 Use Origin Operation Settings (Origin Search Function Enable/Disable)

Programming Console setting address		Settings	Default	Function	Related Auxiliary Area flags/ bits	Time when setting is read by CPU Unit
Word	Bits					
274	00 to 03	0 hex: Disabled 1 hex: Enabled	0 hex	Specifies whether or not the origin search function is used for pulse output 1. Note Interrupt inputs 2 and 3 and PWM(891) output 1 cannot be used when the origin search function is enabled (setting 1) for pulse output 1. High-speed counters 0 and 1 can be used.	---	When power is turned ON

Limit Input Signal Settings

Specify in the following PLC Setup settings whether to use the CW/CCW limit input signals (A54008, A54009, A54108, and A54109) only for origin searches or for all pulse output functions. These settings affect all pulse outputs.

Pulse Output 0 Limit Input Signal Operation (CJ1M CPU Unit Ver. 2.0 Only)

Programming Console setting address		Settings	Default	Function	Related Auxiliary Area flags/ bits	Time when setting is read by CPU Unit
Word	Bits					
256	04 to 07	0 hex: Search only 1 hex: Always	0 hex	Specifies whether to use the CW/CCW limit input signals (reflected in A54008, A54009, A54108, and A54109) only for origin searches or for all pulse output functions.	---	When power is turned ON

**Pulse Output 1 Limit Input Signal Operation
(CJ1M CPU Unit Ver. 2.0 Only)**

Programming Console setting address		Settings	Default	Function	Related Auxiliary Area flags/bits	Time when setting is read by CPU Unit
Word	Bits					
274	04 to 07	0 hex: Search only 1 hex: Always	0 hex	Specifies whether to use the CW/CCW limit input signals (reflected in A54008, A54009, A54108, and A54109) only for origin searches or for all pulse output functions.	---	When power is turned ON

Specify in the following PLC Setup settings whether to undefine the origin when a CW/CCW limit input signal turns ON.

Pulse Output 0 Undefine Origin Setting (CJ1M CPU Unit Ver. 2.0 Only)

Programming Console setting address		Settings	Default	Function	Related Auxiliary Area flags/bits	Time when setting is read by CPU Unit
Word	Bits					
268	12 to 15	0 hex: Hold 1 hex: Undefine	0 hex	Specifies whether to hold the origin setting when the CW/CCW limit input signal is input during execution of an origin search or pulse output function.	---	When operation starts

Pulse Output 1 Undefine Origin Setting (CJ1M CPU Unit Ver. 2.0 Only)

Programming Console setting address		Settings	Default	Function	Related Auxiliary Area flags/bits	Time when setting is read by CPU Unit
Word	Bits					
286	12 to 15	0 hex: Hold 1 hex: Undefine	0 hex	Specifies whether to hold the origin setting when the CW/CCW limit input signal is input during execution of an origin search or pulse output function.	---	When operation starts

Acceleration/Deceleration Curve Settings Pulse Output 0 Speed Curve (CJ1M CPU Unit Ver. 2.0 Only)

Programming Console setting address		Settings	Default	Function	Related Auxiliary Area flags/bits	Time when setting is read by CPU Unit
Word	Bits					
256	12 to 15	0 hex: Trapezium (linear) 1 hex: S-shaped	0 hex	Specifies whether to use S-curve or linear acceleration/deceleration rates for pulse outputs with acceleration/deceleration.	---	When power is turned ON

Pulse Output 1 Speed Curve (CJ1M CPU Unit Ver. 2.0 Only)

Programming Console setting address		Settings	Default	Function	Related Auxiliary Area flags/bits	Time when setting is read by CPU Unit
Word	Bits					
274	12 to 15	0 hex: Trapezium (linear) 1 hex: S-shaped	0 hex	Specifies whether to use S-curve or linear acceleration/deceleration rates for pulse outputs with acceleration/deceleration.	---	When power is turned ON

Note The acceleration/deceleration curve setting applies to all pulse outputs, not just to origin searches. Refer to *S-curve Acceleration/Deceleration* on page 165 for details.

Origin Search Parameters

The various origin search parameters are set in the PLC Setup.

Name		Settings	Time when read
Operating mode		Operating mode 0, 1, or 2	Start of operation
Origin search operation setting		0: Reversal mode 1 1: Reversal mode 2	Start of operation
Origin detection method		0: Read the Origin Input Signal after the Origin Proximity Input Signal goes from OFF→ON→OFF. 1: Read the Origin Input Signal after the Origin Proximity Input Signal goes from OFF→ON. 2: Just read the Origin Input Signal without using the Origin Proximity Input Signal.	Start of operation
Origin search direction		0: CW direction 1: CCW direction	Start of operation
Origin search speed (See note.)	Origin search/return initial speed	00000000 to 000186A0 hex (0 to 100,000 pps)	Start of operation
	Origin search high speed	00000000 to 000186A0 hex (0 to 100,000 pps)	Start of operation
	Origin search proximity speed	00000000 to 000186A0 hex (0 to 100,000 pps)	Start of operation
	Origin search acceleration rate	Pre-Ver. 2.0 CPU Units: 0001 to 07D0 hex (1 to 2,000 pulses/4 ms) CPU Units Ver. 2.0 or later: 0001 to FFFF hex (1 to 65,535 pulses/4 ms)	Start of operation
	Origin search deceleration rate	Pre-Ver. 2.0 CPU Units: 0001 to 07D0 hex (1 to 2,000 pulses/4 ms) CPU Units Ver. 2.0 or later: 0001 to FFFF hex (1 to 65,535 pulses/4 ms)	Start of operation
Origin compensation		80000000 to 7FFFFFFF hex (-2147483648 to 2147483647)	Start of operation
I/O settings		Limit Input Signal type 0: Normally closed (NC) 1: Normally open (NO)	Start of operation
		Origin Proximity Input Signal type 0: Normally closed (NC) 1: Normally open (NO)	Start of operation
		Origin Input Signal type 0: Normally closed (NC) 1: Normally open (NO)	Start of operation
Positioning monitor time		0000 to 270F hex (0 to 9,999 ms)	Start of operation

Note An origin search will not be started unless the origin search proximity speed is less than the origin search high speed and unless the origin search/return initial speed is less than the origin search proximity speed.

Explanation of the Origin Search Parameters

Operating Mode

The operating mode parameter specifies the kind of I/O signals that are used in the origin search. The 3 operating modes indicate whether the Error Counter Reset Output and Positioning Completed Input are used.

Operating mode	I/O signal			Remarks
	Origin Input Signal	Error Counter Reset Output	Positioning Completed Input	
0	The origin position is determined when the Origin Input Signal goes from OFF to ON.	Not used. The origin search operation ends after the origin is detected.	Not used.	The Origin Input Signal will be detected during deceleration. An Origin Input Signal Error (error code 0202) will occur and the motor will decelerate to a stop.
1		Goes ON for 20 to 30 ms when the origin is detected.	After the origin is detected, the origin search will not be end until the Positioning Completed Input is received from the driver.	The Origin Input Signal will not be detected during deceleration. When the Origin Input Signal is detected after the motor has reached the proximity speed for origin search, the motor will be stopped and the origin search operation will end.
2				

The following table shows the proper operating mode settings for different drivers and applications.

Driver	Remarks	Operating mode
Stepping motor driver (See note.)		0
Servo driver	Use this mode when you want to reduce the processing time, even at the expense of positioning accuracy. (The Servo Driver's positioning complete signal is not used.)	1
	Use this mode when you want high positioning accuracy. (The Servo Driver's positioning complete signal is used.)	2

Note There are stepping motor drivers that are equipped with a positioning completed signal like a Servo driver. Operating modes 1 and 2 can be used with these stepping motor drivers.

■ Remarks: Operations Detecting the Origin During Deceleration from High Speed

Operating Mode 0 (without Error Counter Reset Output, without Positioning Completed Input)

Connect the sensor's open collector output signal to the Origin Input Signal. The Origin Input Signal's response time is 0.1 ms when set as a NO contact.

When the Origin Proximity Input Signal is received, the motor will begin decelerating from the origin search high speed to the origin search proximity speed. In this operating mode, the Origin Input Signal will be detected if it is received during this deceleration and an Origin Input Signal Error (error code 0202) will be generated. In this case, the motor will decelerate to a stop.

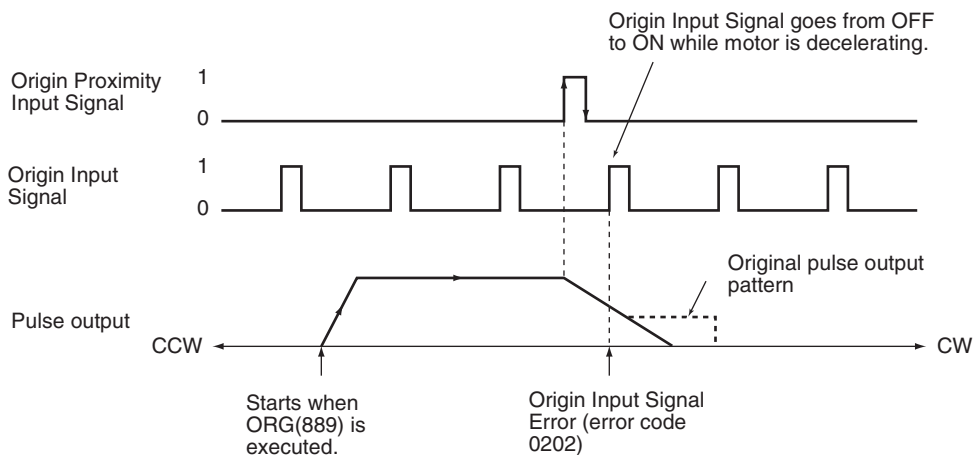

Operating Mode 1 (with Error Counter Reset Output, without Positioning Completed Input)

Connect the phase-Z signal from the Servo Driver to the Origin Input Signal. When the Origin Input Signal is received, the pulse output will be stopped and the Error Counter Reset Signal will be output for about 20 to 30 ms.

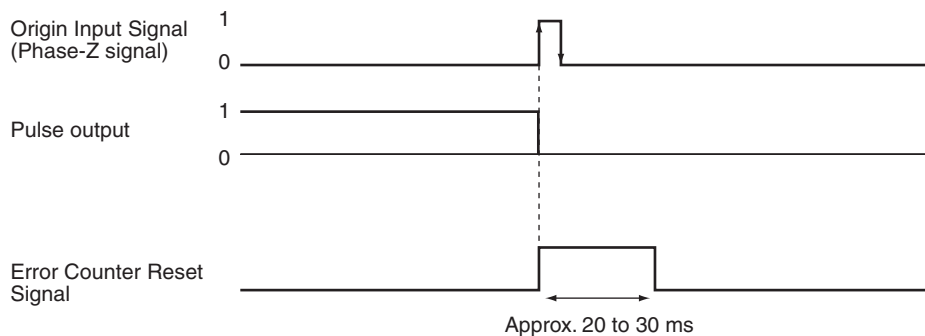

When the Origin Proximity Input Signal is received, the motor will begin decelerating from the origin search high speed to the origin search proximity speed. In this operating mode, the Origin Input Signal will be ignored if it is received during this deceleration. After deceleration is completed, the Origin Input Signal will be detected and the motor will stop.

Operating Mode 1 with Origin Proximity Input Signal Reverse (Origin Detection Method Setting = 0)

When the deceleration time is short, the Origin Input Signal can be detected immediately after the Origin Proximity Input Signal goes from ON to OFF. Set a Origin Proximity Input Signal dog setting that is long enough (longer than the deceleration time.)

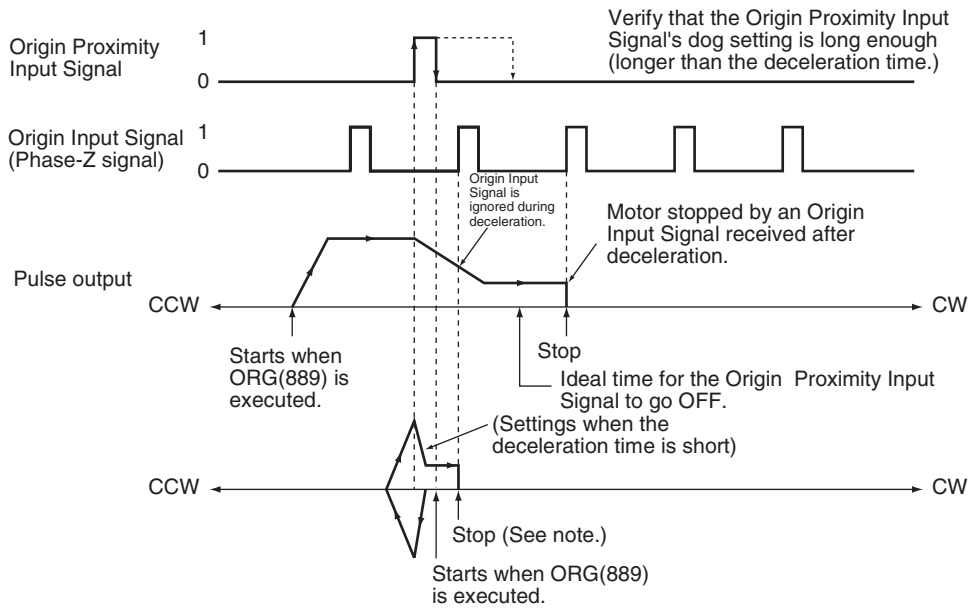

Note: The Origin Input Signal can be detected immediately after the Origin Proximity Input Signal goes from ON to OFF if the deceleration time is short, e.g., starting from within the Origin Proximity Input Signal.

Operating Mode 1 without Origin Proximity Input Signal Reverse (Origin Detection Method Setting = 1)

Depending on the length of the deceleration time, the stopping position may change when the Origin Input Signal is detected during deceleration.

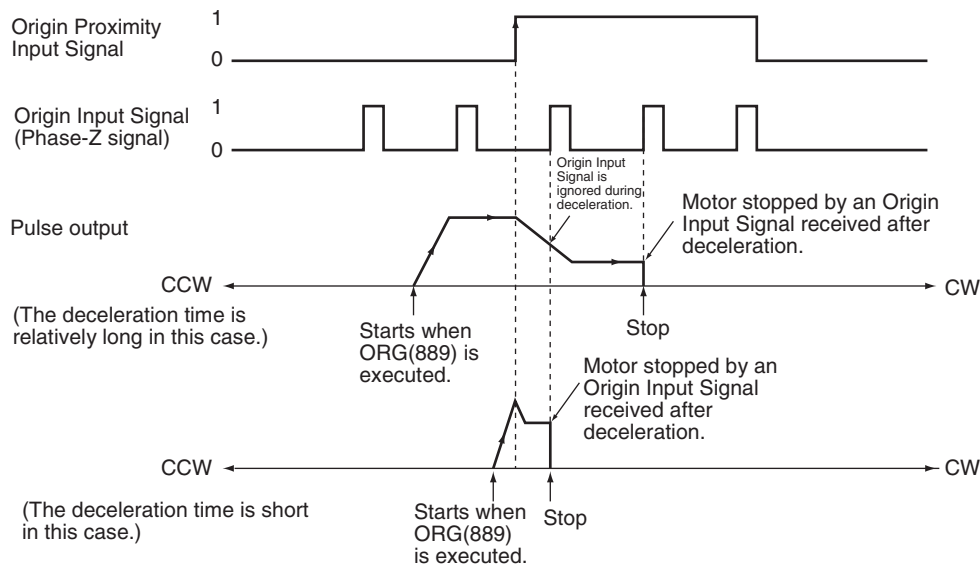

Operating Mode 2 (with Error Counter Reset Output, with Positioning Completed Input)

This operating mode is the same as mode 1, except the Positioning Completed Signal (INP) from the Servo Driver is used. With origin search 0, the Positioning Completed Signal from the Servo Driver connects to IN4. With origin search 1, it connects to IN5.

If origin compensation is not being applied, the Positioning Completed Signal is checked after the Error Counter Reset Output. If origin compensation is

being applied, the Positioning Completed Signal is checked after the compensation operation is completed.

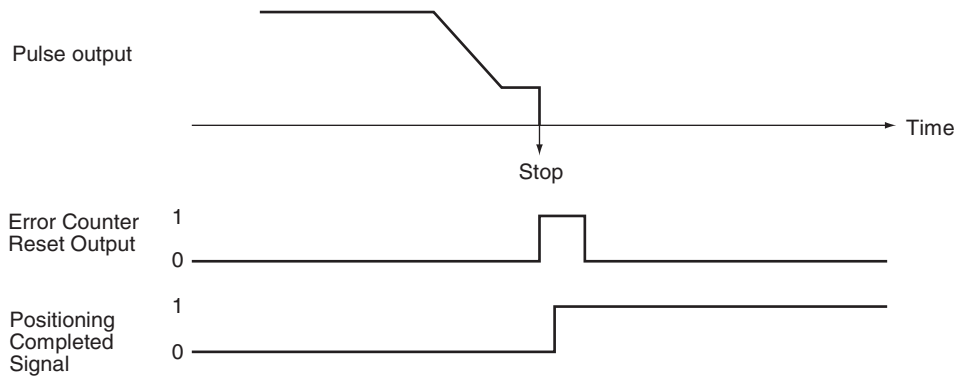

Origin Search Operation Setting

Select either of the following two reverse modes for the origin search operation at the limit in the origin search direction.

Setting	Description
0: Reversal mode 1	When the limit input signal is received in the origin search direction, reverse and continue operation.
1: Reversal mode 2	When the limit input signal is received in the origin search direction, generate an error and stop operation.

Origin Detection Method

Select one of the following methods that specify the treatment of the Origin Proximity Input Signal.

Setting	Description
0: Origin Proximity Input Signal reversal required.	Reads the first Origin Input Signal after the Origin Proximity Input Signal goes OFF→ON→OFF.
1: Origin Proximity Input Signal reversal not required.	Reads the first Origin Input Signal after the Origin Proximity Input Signal goes OFF→ON.
2: Origin Proximity Input Signal not used.	Just read the Origin Input Signal without using the Origin Proximity Input Signal.

Origin Detection Method 0: Origin Proximity Input Signal Reversal Required

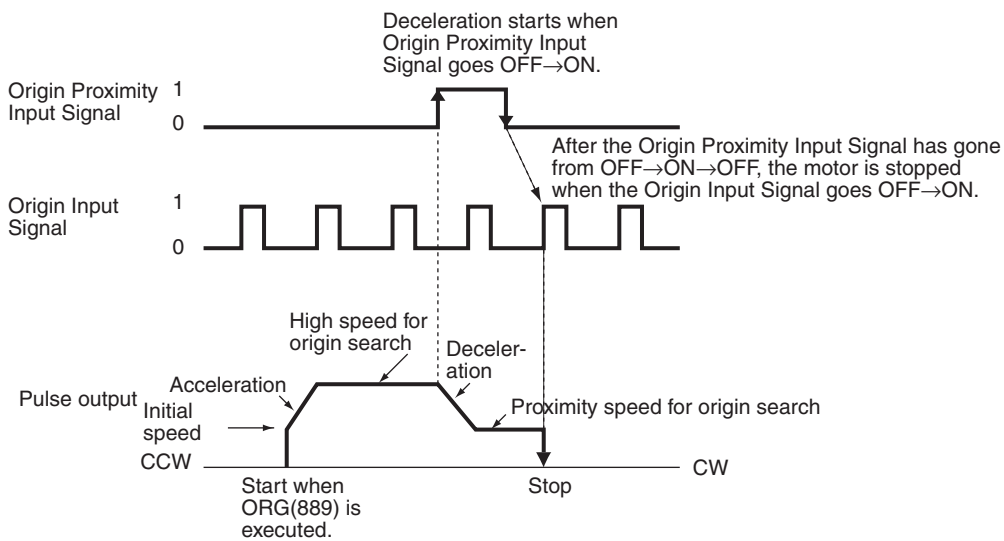

Origin Detection Method 1: Origin Proximity Input Signal Reversal Not Required

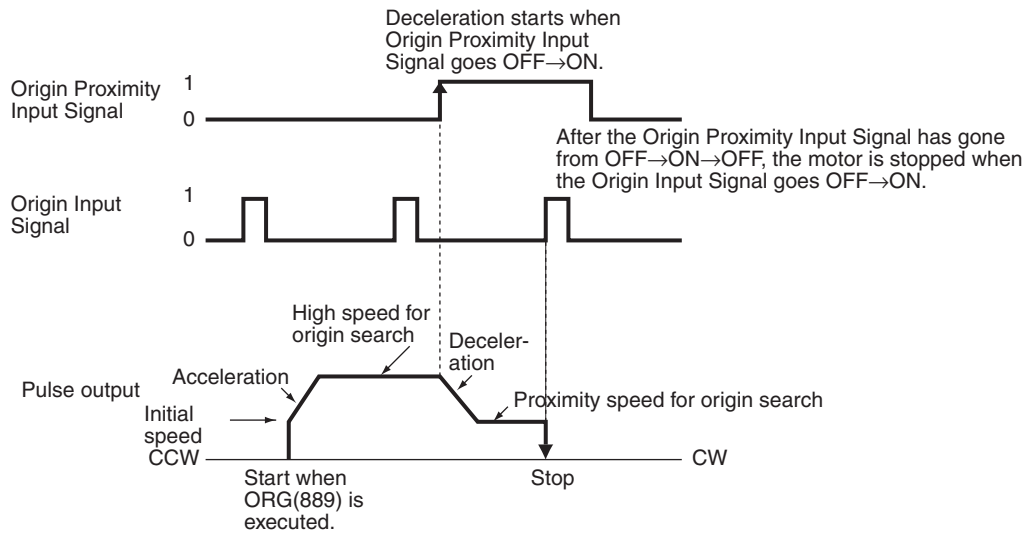

Origin Detection Method 2: Origin Proximity Input Signal Reversal Not Used

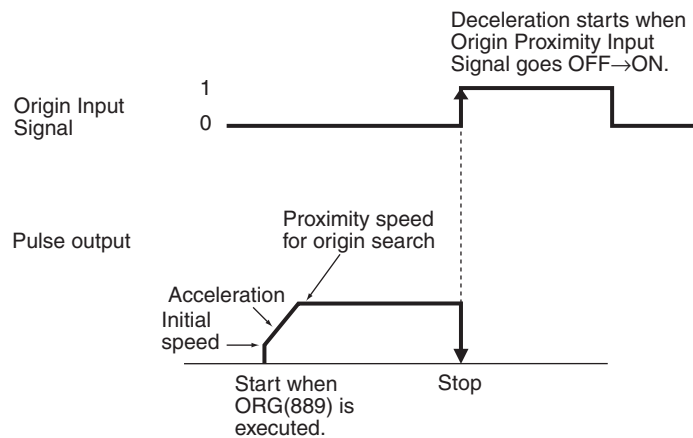

Origin Search Operating Mode and Origin Detection Method Settings

The following examples explain how the operation patterns are affected by the origin search operation and origin detection method settings.

These examples have a CW origin search direction. (The search direction and limit input signal direction would be different for an origin search in the CCW direction.)

Using Reversal Mode 1

Origin search operation Origin detection method	0: Reversal mode 1
0: Origin Proximity Input Signal reversal required.	<p>Note When the limit input signal is received, the motor stops without deceleration, reverses direction, and accelerates.</p>
1: Origin Proximity Input Signal reversal not required.	<p>Note When the limit input signal is received, the motor stops without deceleration, reverses direction, and accelerates.</p>
2: Origin Proximity Input Signal not used.	<p>Note When the direction of operation is reversed, it is reversed immediately without deceleration or acceleration.</p>

Using Reversal Mode 2

Origin search operation Origin detection method	1: Reversal mode 2
0: Origin Proximity Input Signal reversal required.	<p>Note When the limit input signal is received, the motor stops without deceleration.</p>
1: Origin Proximity Input Signal reversal not required.	<p>Note When the limit input signal is received, the motor stops without deceleration.</p>

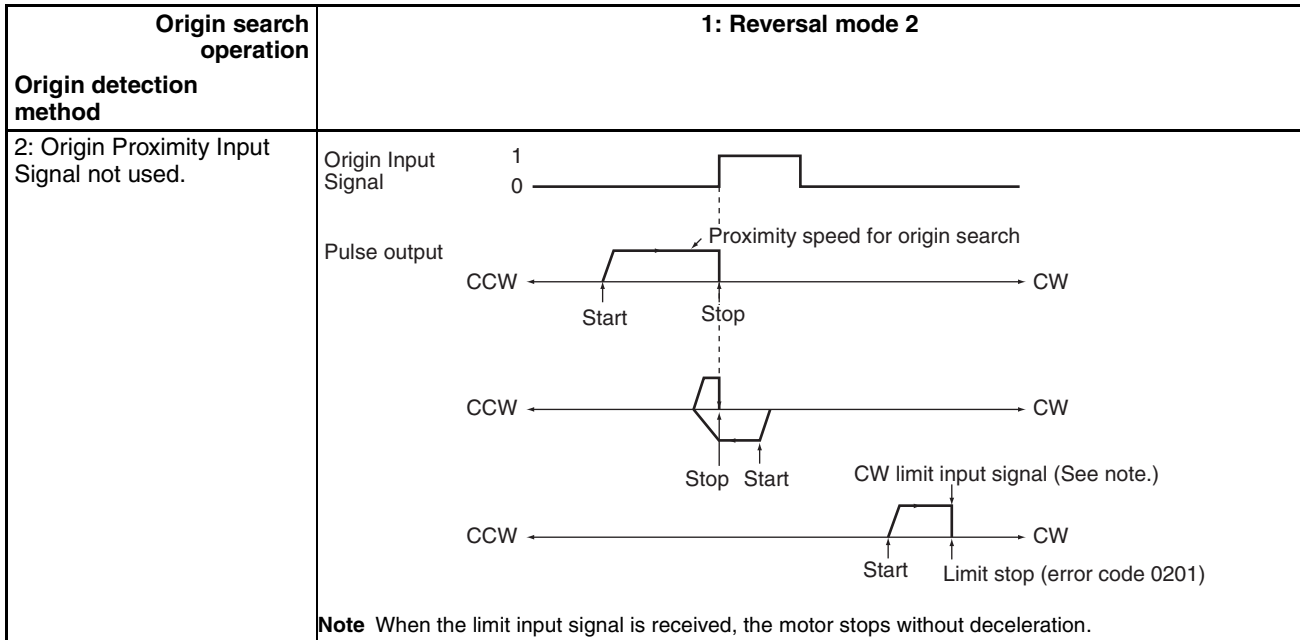

Specifying the Origin Search Direction (CW or CCW Direction)

Sets the direction to move when detecting the Origin Input Signal. Typically, the origin search is performed so that the Origin Input Signal's rising edge is detected when moving in the origin search direction.

Setting	Description
0	CW direction
1	CCW direction

Origin Search Speed

These are the motor speed settings used in the origin search.

Origin Search/Return Initial Speed

Sets the motor's starting speed when the origin search is executed. Specify the speed in the number of pulses per second (pps).

Origin Search High Speed

Sets the motor's target speed when the origin search is executed. Specify the speed in the number of pulses per second (pps).

Origin Search Proximity Speed

Sets the motor's speed after the Origin Proximity Input Signal is detected. Specify the speed in the number of pulses per second (pps).

Origin Search Acceleration Rate

Sets the motor's acceleration rate when the origin search is executed. Specify the amount to increase the speed (Hz) per 4-ms interval.

Origin Search Deceleration Rate

Sets the motor's acceleration rate when the origin search function is decelerating. Specify the amount to decrease the speed (Hz) per 4-ms interval.

Origin Compensation

After the origin has been determined, the origin compensation can be set to compensate for a shift in the Proximity Sensor's ON position, motor replacement, or other change.

Once the origin has been detected in an origin search, the number of pulses specified in the origin compensation is output, the current position is reset to 0, and the pulse output's No-origin Flag is turned OFF.

Setting range: 80000000 to 7FFFFFFF hex (-2,147,483,648 to 2,147,483,647) pulses

I/O Settings

Limit Input Signal Type

Specifies the type of input signal (normally closed or normally open) being used for the limit inputs.

- 0: NC
- 1: NO

Origin Proximity Input Signal Type

Specifies the type of input signal (normally closed or normally open) being used for the Origin Proximity Input Signal.

- 0: NC
- 1: NO

Origin Input Signal Type

Specifies the type of input signal (normally closed or normally open) being used for the Origin Input Signal.

- 0: NC
- 1: NO

Positioning Monitor Time

When the operating mode is set to mode 2, this setting specifies how long to wait (in ms) for the Positioning Completed Signal after the positioning operation has been completed, i.e., the pulse output has been completed. A Positioning Timeout Error (error code 0300) will be generated if the motor driver's Positioning Completed Signal does not come ON within the specified time.

Setting range: 0000 to 270F hex (0 to 9,999 ms)

The actual monitoring time will be the Positioning Monitor Time rounded up to the nearest 10-ms unit + 10 ms max.

If the Positioning Monitor Time is set to 0, the function will be disabled and the Unit will continue waiting for the Positioning Completed Signal to come ON. (A Positioning Timeout Error will not be generated.)

Executing an Origin Search

Execute ORG(889) in the ladder program to perform an origin search with the specified parameters.

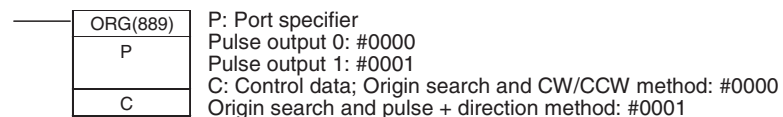

Restrictions

The motor can be moved even if the origin position has not been determined with the origin search function, but positioning operations will be limited as follows:

Function	Operation
Origin return	Cannot be used.
Positioning with absolute pulse specification	Cannot be used.
Positioning with relative pulse specification	Outputs the specified number of pulses after setting the current position to 0.

An origin search will not be started unless the origin search proximity speed is less than the origin search high speed and unless the origin search/return initial speed is less than the origin search proximity speed.

6-3-3 Origin Search Error Processing

The CJ1M CPU Unit's pulse output function performs a basic error check before starting to output pulses (when the instruction is executed) and will not output pulses if the settings are incorrect. There are other errors that can occur with the origin search function during pulse output, which may stop the pulse output.

If an error occurs that stops pulse output, the pulse output's Output Stopped Error Flag (A28007 or A28107) will be turned ON and the Pulse Output Stop Error Code will be written to A444 or A445. Use these flags and error codes to identify the cause of the error.

The Pulse Output Stop Errors will not affect the CPU Unit's operating status. (The Pulse Output Stop Errors do not cause a fatal or non-fatal error in the CPU Unit.)

Related Auxiliary Area Flags

Word	Bits	Function		Read/Write
A280	07	Pulse output 0	Pulse Output Stopped Error Flag 0: No error 1: Stop error occurred	Read only
A281	07	Pulse output 1	Pulse Output Stopped Error Flag 0: No error 1: Stop error occurred	Read only
A444	00 to 15	Pulse output 0	Pulse Output 0 Stop Error Code (See table below.)	Read only
A445	00 to 15	Pulse output 1	Pulse Output 1 Stop Error Code (See table below.)	Read only

Pulse Output Stop Error Codes

Error name	Error code	Likely cause	Corrective action	Operation after error
CW Limit Stop Input Signal	0100	Stopped due to a CW limit signal input.	Move in the CCW direction.	Immediate stop, No effect on other port
CCW Limit Stop Input Signal	0101	Stopped due to a CCW limit signal input.	Move in the CW direction.	
No Origin Proximity Input Signal	0200	The parameters indicate that the Origin Proximity Input Signal is being used, but a Origin Proximity Input Signal was not received during the origin search.	Check the wiring of the Origin Proximity Input Signal as well as the PLC Setup's Origin Proximity Input Signal Type setting (NC or NO) and execute the origin search again. Turn the power supply OFF and then ON if the signal type setting was changed.	No effect on other port
No Origin Input Signal	0201	The Origin Input Signal was not received during the origin search.	Check the wiring of the Origin Input Signal as well as the PLC Setup's Origin Input Signal Type setting (NC or NO) and execute the origin search again. Turn the power supply OFF and then ON if the signal type setting was changed.	

Error name	Error code	Likely cause	Corrective action	Operation after error
Origin Input Signal Error	0202	During an origin search in operating mode 0, the Origin Input Signal was received during the deceleration started after the Origin Proximity Input Signal was received.	Take one or both of the following steps so that the Origin Input Signal is received after deceleration is completed. <ul style="list-style-type: none"> •Increase the distance between the Origin Proximity Input Signal sensor and Origin Input Signal sensor. •Decrease the difference between the origin search's high speed and proximity speed settings. 	Decelerates to a stop, No effect on other port
Limit Inputs in Both Directions	0203	The origin search cannot be performed because the limit signals for both directions are being input simultaneously.	Check the wiring of the limit signals in both directions as well as the PLC Setup's Limit Signal Type setting (NC or NO) and execute the origin search again. Turn the power supply OFF and then ON if the signal type setting was changed.	Operation will not start. No effect on other port
Simultaneous Origin Proximity and Limit Inputs	0204	The Origin Proximity Input Signal and the Limit Input Signal in the search direction are being input simultaneously during an origin search.	Check the wiring of the Origin Proximity Input Signal and the Limit Input Signal. Also check the PLC Setup's Origin Proximity Input Signal Type and Limit Signal Type settings (NC or NO) and then execute the origin search again. Turn the power supply OFF and then ON if a signal type setting was changed.	Immediate stop, No effect on other port
Limit Input Signal Already Being Input	0205	<ul style="list-style-type: none"> •When an origin search in one direction is being performed, the Limit Input Signal is already being input in the origin search direction. •When a non-regional origin search is being performed, the Origin Input Signal and the Limit Input Signal in the opposite direction (from the search direction) are being input simultaneously. 	Check the wiring of the Limit Input Signal and the PLC Setup's I/O settings. Also check the PLC Setup's Limit Signal Type setting (NC or NO) and then execute the origin search again. Turn the power supply OFF and then ON if the signal type setting was changed.	Immediate stop, No effect on other port
Origin Proximity Input Signal Origin Reverse Error	0206	<ul style="list-style-type: none"> •When an origin search with reversal at the limit is being performed, the Limit Input Signal in the search direction was input while the Origin Proximity Input Signal was reversing. •When an origin search with reversal at the limit is being performed and the Origin Proximity Input Signal is not being used, the Limit Input Signal in the search direction was input while the Origin Input Signal was reversing. 	Check the installation positions of the Origin Proximity Input Signal, Origin Input Signal, and Limit Input Signal as well as the PLC Setup's I/O settings. Also check the PLC Setup's Signal Type settings (NC or NO) for each input signal and then execute the origin search again. Turn the power supply OFF and then ON if a signal type setting was changed.	Immediate stop, No effect on other port
Positioning Timeout Error	0300	The Servo Driver's Positioning Completed Signal does not come ON within the Positioning Monitor Time specified in the PLC Setup.	Adjust the Positioning Monitor Time setting or Servo system gain setting. Check the Positioning Completed Signal wiring, correct it if necessary, and then execute the origin search again.	Decelerates to a stop, No effect on other port

6-3-4 Origin Search Examples

Operation

Connect a Servo Driver and execute an origin search based on the Servomotor's built-in encoder phase-Z signal and a Origin Proximity Input Signal.

Conditions

- Operating mode: 1
(Uses the Servomotor encoder's phase-Z signal as the Origin Input Signal.)
- Origin search operation setting: 0
(Sets reverse mode 1. Reverses direction when the limit input signal is input in the origin search direction.)
- Origin detection method: 0
(Reads the Origin Input Signal after the Origin Input Signal goes OFF→ON→OFF.)
- Origin search direction: 0 (CW direction)

System Configuration

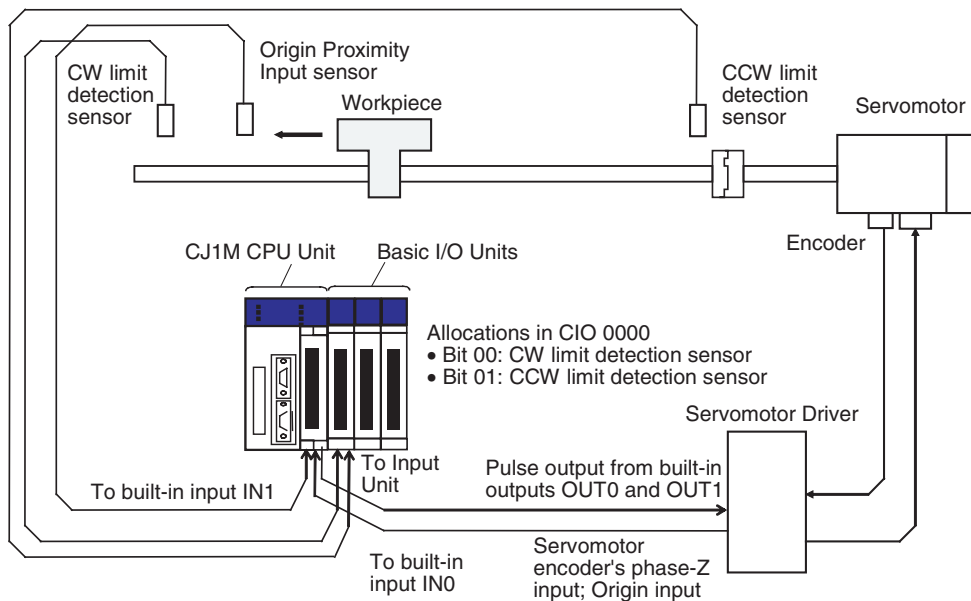

Instructions Used

ORG(889)

I/O Allocations

Inputs

Built-in I/O terminal	Bit address	Name
IN0	CIO 296000	Origin Search 0 (Origin Input Signal) (Servomotor encoder's phase-Z signal)
IN1	CIO 296000	Origin Search 0 (Origin Proximity Input Signal)
---	A54008	Pulse Output 0 CW Limit Input Signal
---	A54009	Pulse Output 0 CCW Limit Input Signal
---	CIO 000000	CW limit detection sensor
---	CIO 000001	CCW limit detection sensor

Outputs

Built-in I/O terminal	Bit address	Name
OUT0	CIO 296100	Pulse Output 0 (CW)
OUT1	CIO 296101	Pulse Output 0 (CCW)

Operation

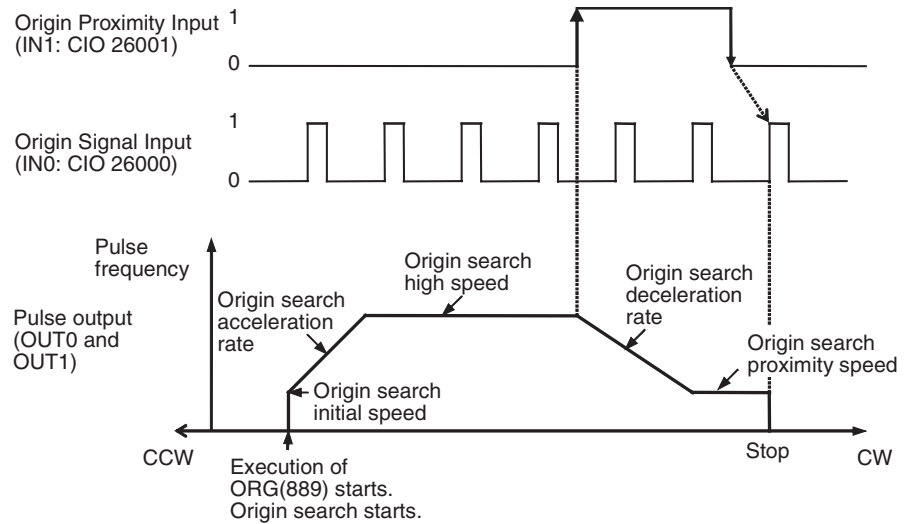

PLC Setup Settings

Programming Console address	Bits	Function	Setting (example)
256	00 to 03	Pulse Output 0 Origin Search Function Enable/Disable	1 hex: Enabled
257	00 to 03	Pulse Output 0 Origin Search Operating Mode	1 hex: Mode 1
	04 to 07	Pulse Output 0 Origin Search Operation Setting	0 hex: Reverse mode 1
	08 to 11	Pulse Output 0 Origin Detection Method	0 hex: Origin detection method 0
	12 to 15	Pulse Output 0 Origin Search Direction Setting	0 hex: CW direction
258	00 to 15	Pulse Output 0 Origin Search/Return Initial Speed	0064 hex (100 pps)
259	00 to 15		0000 hex
260	00 to 15	Pulse Output 0 Origin Search High Speed	07D0 hex (2,000 pps)
261	00 to 15		0000 hex
262	00 to 15	Pulse Output 0 Origin Search Proximity Speed	03E8 hex (1,000 pps)
263	00 to 15		0000 hex
264	00 to 15	Pulse Output 0 Origin Compensation	0000 hex
265	00 to 15		0000 hex
266	00 to 15	Pulse Output 0 Origin Search Acceleration Rate	0032 hex (50 Hz/4 ms)
267	00 to 15	Pulse Output 0 Origin Search Deceleration Rate	0032 hex (50 Hz/4 ms)
268	00 to 03	Pulse Output 0 Limit Input Signal Type	1: NO
	04 to 07	Pulse Output 0 Origin Proximity Input Signal Type	1: NO
	08 to 11	Pulse Output 0 Origin Input Signal Type	1: NO

Ladder Program

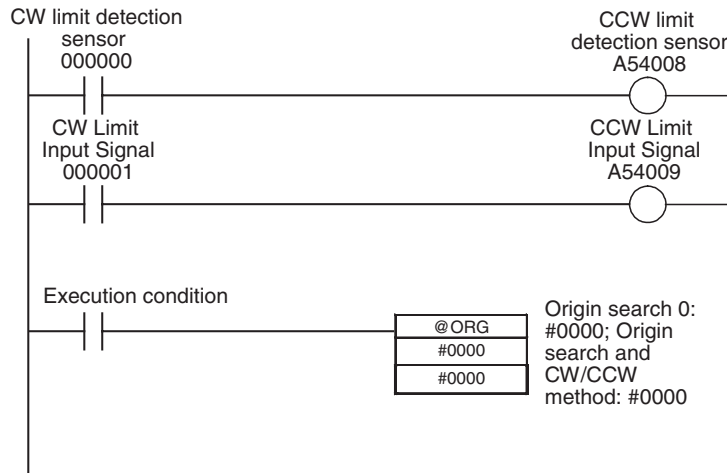

6-3-5 Origin Return

Overview

Moves the motor to the origin position from any other position. The origin return operation is controlled by ORG(889).

The origin return operation returns the motor to the origin by starting at the specified speed, accelerating to the target speed, moving at the target speed, and then decelerating to a stop at the origin position.

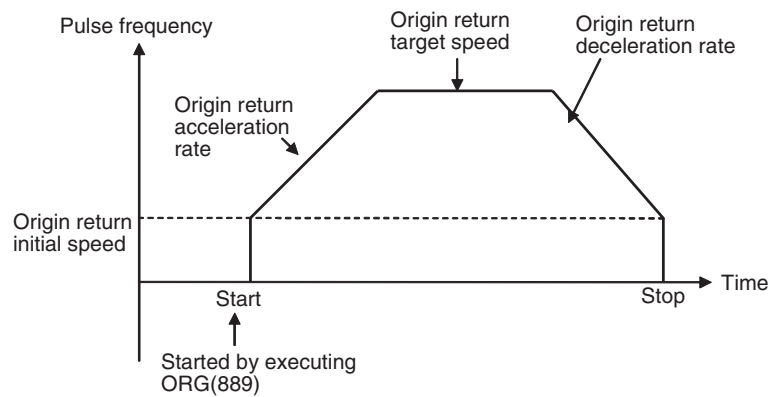

Procedure

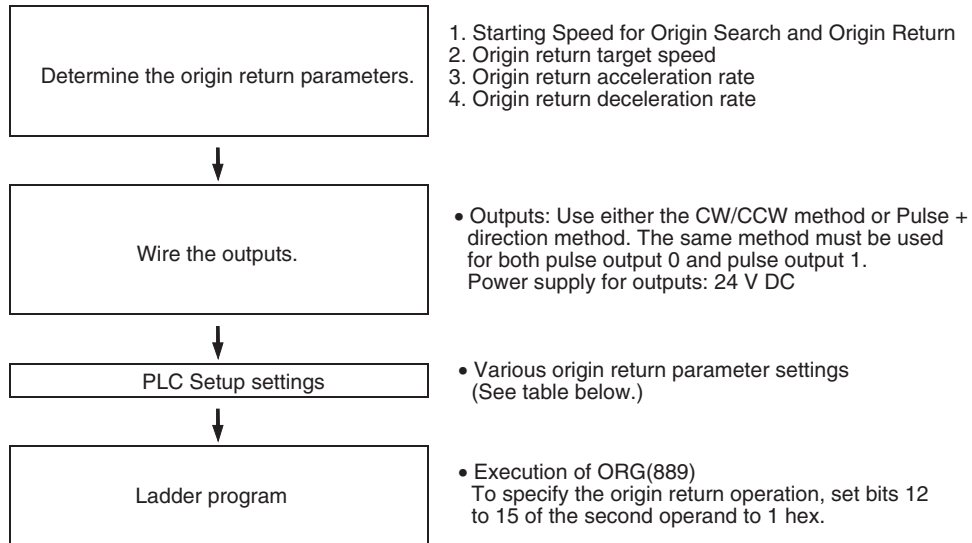

PLC Setup Settings

The various origin return parameters are set in the PLC Setup.

Origin Return Parameters

Name	Settings	Remarks
Origin search/return initial speed	00000000 to 000186A0 hex (0 to 100,000 pps)	Start of operation
Origin return target speed	00000000 to 000186A0 hex (0 to 100,000 pps)	
Origin return acceleration rate	0001 to 07D0 hex (1 to 2,000 Hz/4 ms)	
Origin return deceleration rate	0001 to 07D0 hex (1 to 2,000 Hz/4 ms)	

Explanation of the Origin Return Parameters

- Origin Search/Return Initial Speed** Sets the motor's starting speed when the origin return is executed. Specify the speed in the number of pulses per second (pps).
- Origin Return Target Speed** Sets the motor's target speed when the origin return is executed. Specify the speed in the number of pulses per second (pps).
- Origin Return Acceleration Rate** Sets the motor's acceleration rate when the origin return operation starts. Specify the amount to increase the speed (Hz) per 4-ms interval.
- Origin Return Deceleration Rate** Sets the motor's acceleration rate when the origin return function is decelerating. Specify the amount to decrease the speed (Hz) per 4-ms interval.

Executing an Origin Return

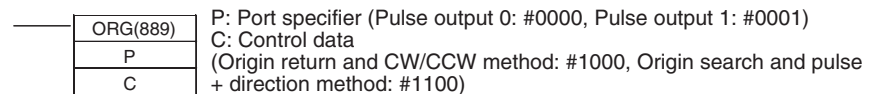

Note An instruction execution error will occur if the origin is not determined (relative coordinate system) when ORG(889) is executed to perform an origin return operation.

SECTION 7

Programming Examples

This section provides examples of programming built-in I/O.

7-1	Built-in Outputs	192
7-1-1	Using Interrupts to Read Input Pulses (Length Measurement)	192
7-1-2	Outputting Pulses after a Preset Delay	195
7-1-3	Positioning (Trapezoidal Control)	197
7-1-4	Jog Operation	199
7-1-5	Cutting Long Material Using Fixed Feeding	201
7-1-6	Vertically Conveying PCBs (Multiple Progressive Positioning) . . .	204
7-1-7	Palletize: Two-axis Multipoint Positioning	209
7-1-8	Feeding Wrapping Material: Interrupt Feeding	217

7-1 Built-in Outputs

7-1-1 Using Interrupts to Read Input Pulses (Length Measurement)

Specifications and Operation

This example program reads the number of encoder pulses input with high-speed counter 1 and also reads sensor inputs 1 and 2 as interrupt inputs at terminals IN1 (2960.01) and IN3 (2960.03). The workpiece length is measured by the number of pulses counted between the ON input at sensor input 1 and the ON input at sensor input 2.

The interrupt task triggered by built-in input 1 (IN1) clears the PV of high-speed counter 1. The interrupt task triggered by built-in input 3 (IN3) reads the PV of high-speed counter 1 and stores the result in D00010.

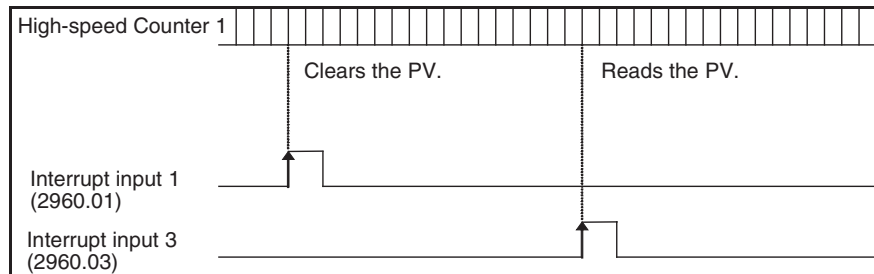

Instructions Used

- MSKS(690) Enables the I/O interrupts.
- INI(880) Changes the high-speed counter PV. (Clears it to 0.)
- PRV(881) Reads the high-speed counter PV.

Preparation

PLC Setup Settings

High-speed Counter Input and Interrupt Input Settings

PLC Setup setting details	Address	Data
Use high-speed counter 1 (100 kHz). Linear mode, Software reset, and Increment pulse input	053	2013 hex
Use built-in inputs IN1 and IN3 as interrupt inputs.	060	1010 hex
Disable origin search function for pulse output 0.	256	0000 hex
Disable origin search function for pulse output 1.	274	0000 hex

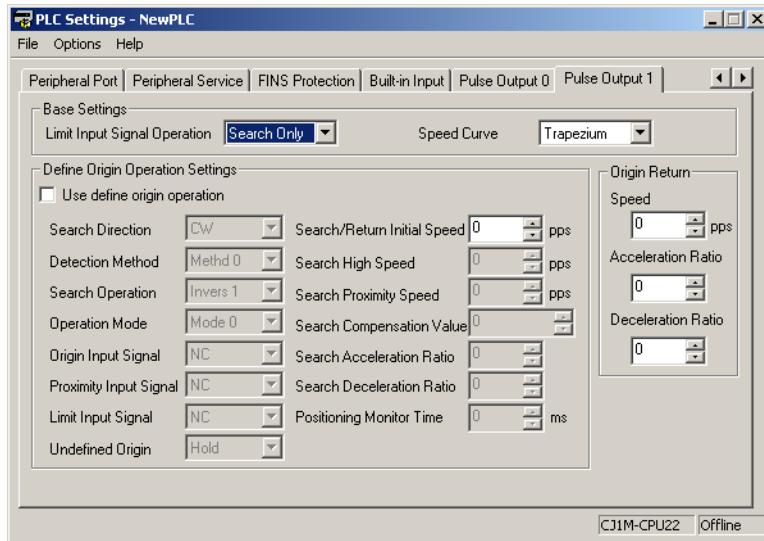
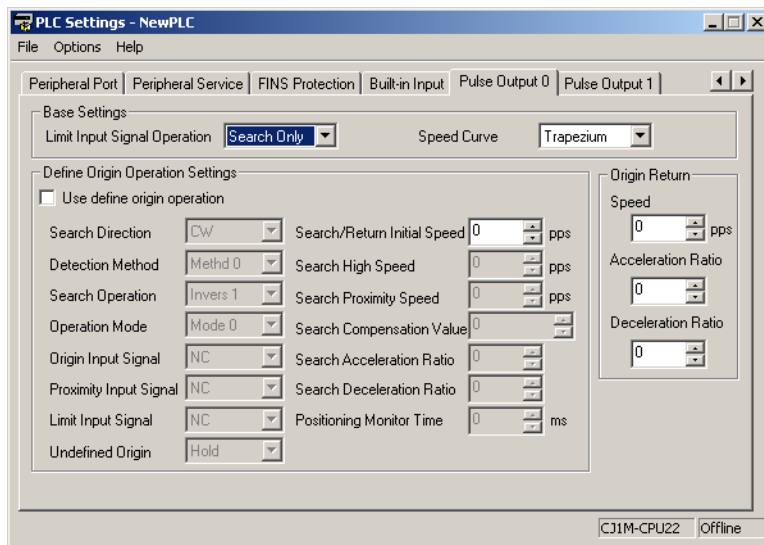
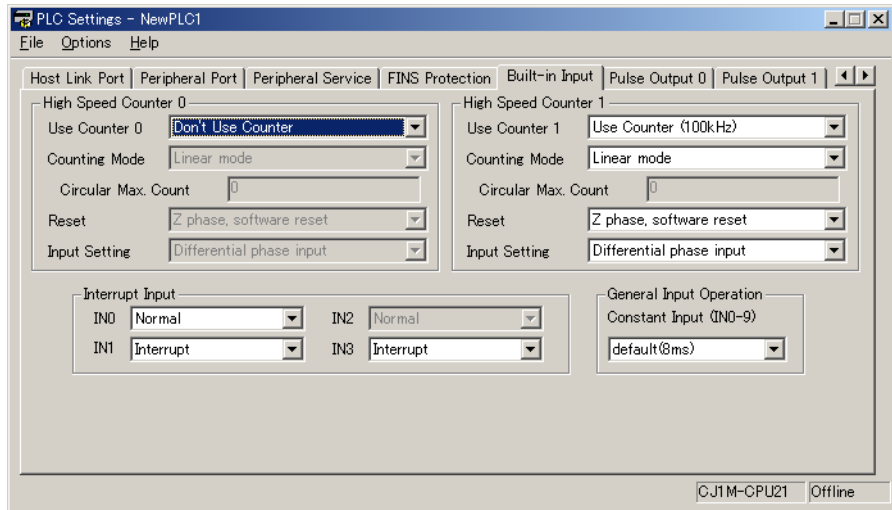

Ladder Program

Cyclic Task (Task 0)

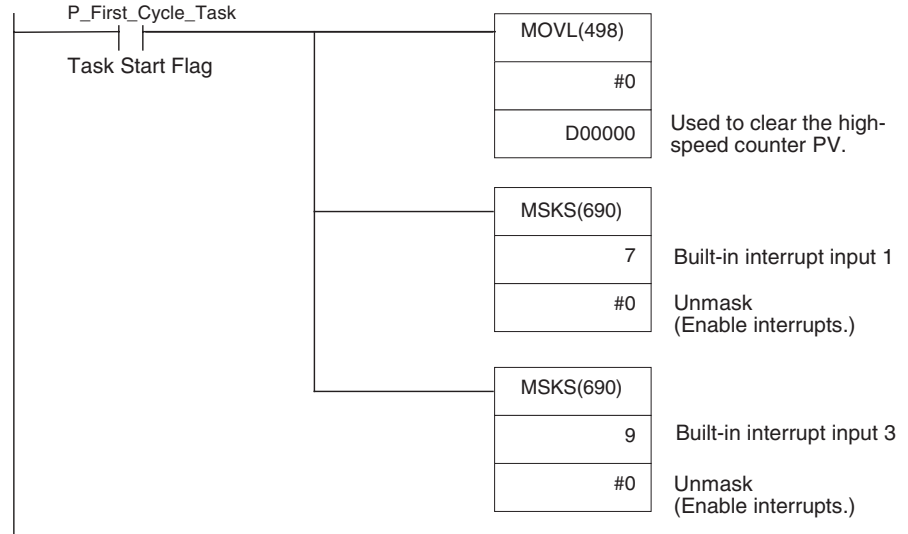

Built-in Input 1 Interrupt Task (Interrupt Task 141)

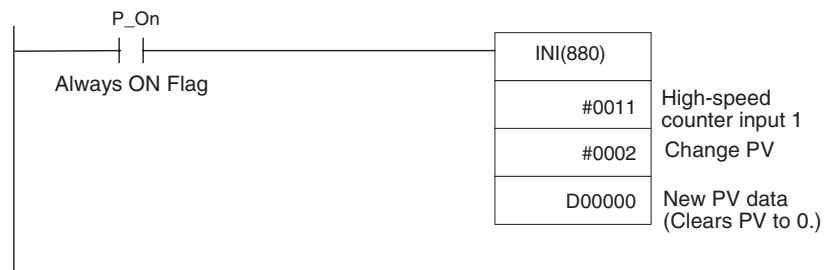

Built-in Input 3 Interrupt Task (Interrupt Task 143)

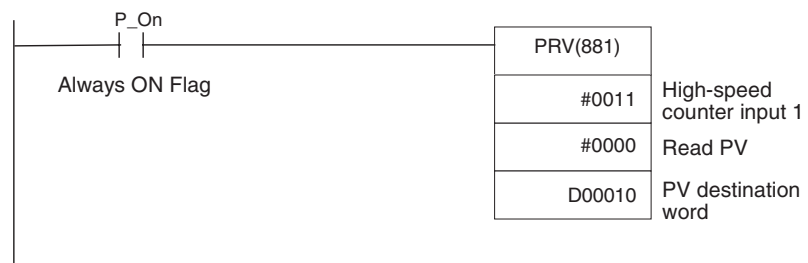

7-1-2 Outputting Pulses after a Preset Delay

Specifications and Operation

This example program waits for a preset time (0.5 ms) after the interrupt input (2960.03) goes ON and then outputs 100,000 pulses at 100 kHz from pulse output 0.

The I/O interrupt task starts a scheduled interrupt with a scheduled time of 0.5 ms. The scheduled interrupt task executes the pulse output instruction and stops the scheduled interrupt.

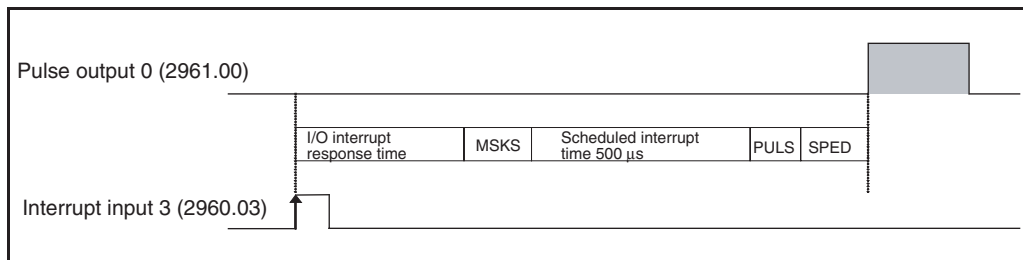

Instructions Used

- MSKS(690) Enables the I/O interrupt. Starts the scheduled interrupt.
- PULS(886) Sets the number of output pulses.
- SPED(885) Starts the pulse output.

Preparation

PLC Setup Settings

Built-in Input (IN3: 2960.03) Settings

PLC Setup setting details	Address	Data
Use built-in inputs IN3 as an interrupt input.	060	1000 hex
Do not use high-speed counter 0.	050	0000 hex
Disable origin search function for pulse output 1.	274	0000 hex

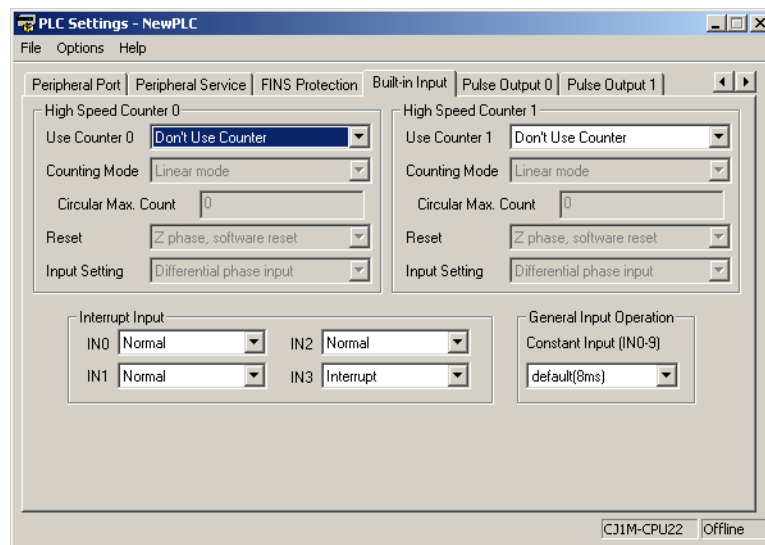

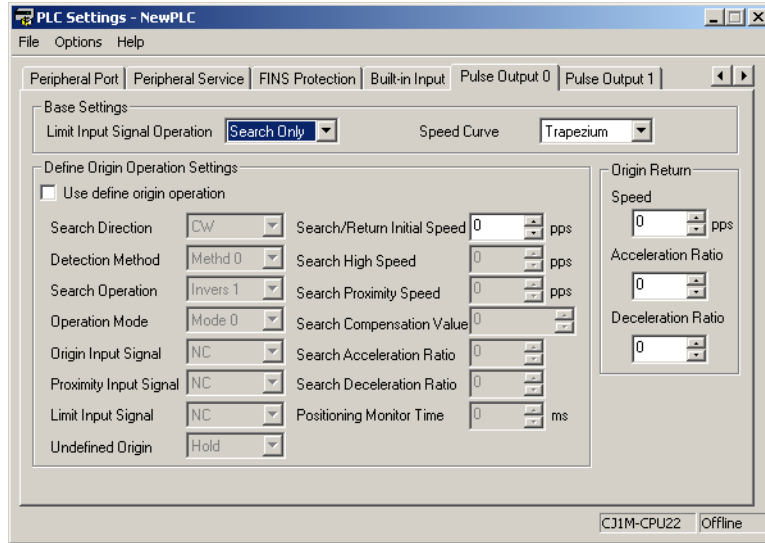

Scheduled Interrupt Time Unit Setting

PLC Setup setting details	Address	Data
Set the scheduled interrupt time units to 0.1 ms.	195	0002 hex

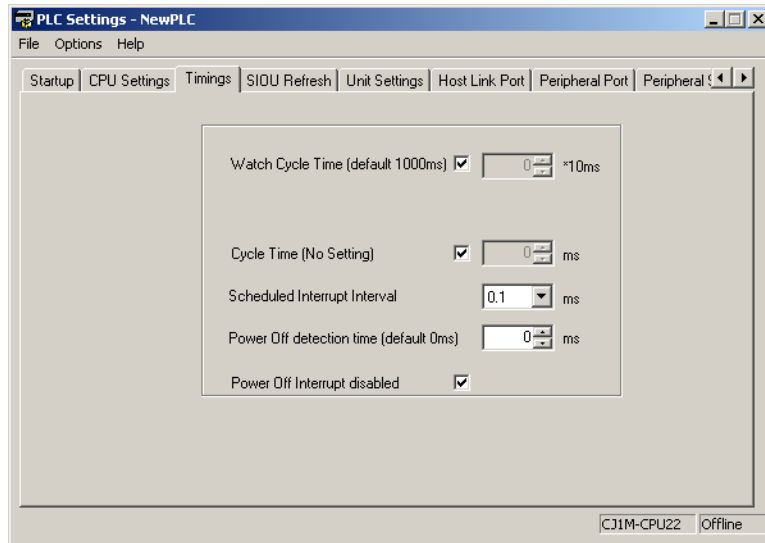

Ladder Program

Cyclic Task (Task 0)

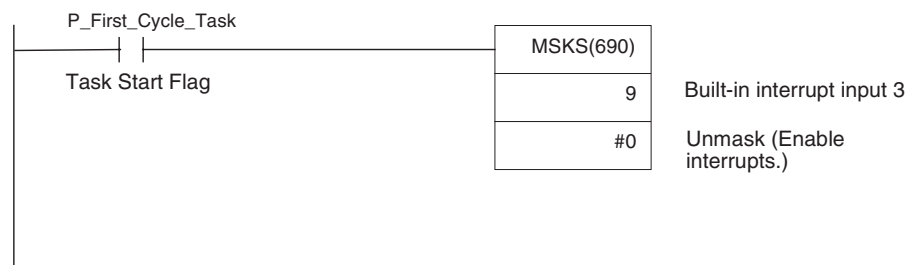

Built-in Input 3 Interrupt Task (Interrupt Task 143)

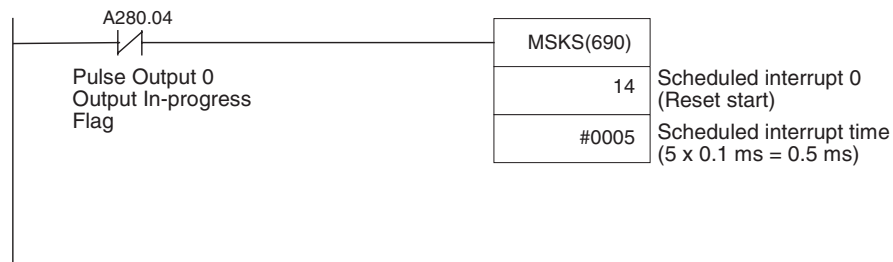

Scheduled Interrupt Task 0 (Interrupt Task 2)

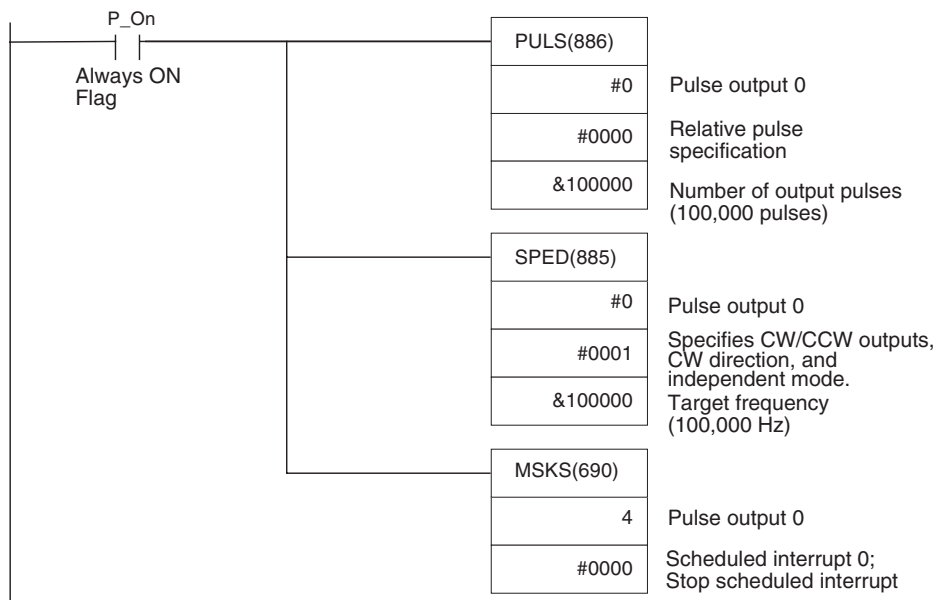

7-1-3 Positioning (Trapezoidal Control)

Specifications and Operation

When the start input (2960.06) goes ON, this example program outputs 600,000 pulses from pulse output 1 and turns the motor.

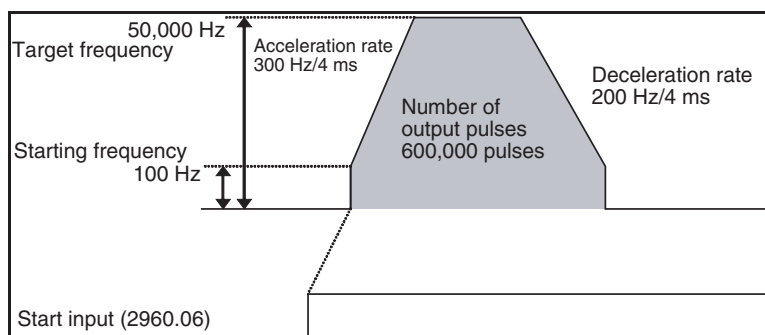

Instructions Used

PLS2(887)

Preparation

PLC Setup Settings

There are no settings that need to be made in the PLC Setup.

DM Area Settings

PLS2(887) Settings (D00000 to D00007)

Setting details	Address	Data
Acceleration rate: 300 Hz/4 ms	D00000	#012C
Deceleration rate: 200 Hz/4 ms	D00001	#00C8
Target frequency: 50,000 Hz	D00002	#C350
	D00003	#0000
Number of output pulses: 600,000 pulses	D00004	#27C0
	D00005	#0009
Starting frequency: 100 Hz	D00006	#0064
	D00007	#0000

Ladder Program

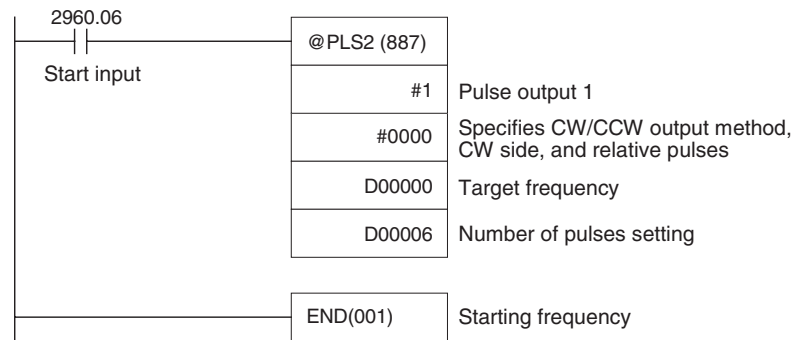

Remarks

- Absolute pulses can be specified when the origin position has been determined.
- If a target frequency that cannot be reached has been set, the target frequency will be reduced automatically, i.e., triangular control will be performed. In some cases where the acceleration rate is substantially greater than the deceleration rate, the operation won't be true triangular control. The motor will be operated at a constant speed for a short time between the acceleration and deceleration.

7-1-4 Jog Operation

Specifications and Operation

- Low-speed jog operation (CW) will be executed from pulse output 1 while input 2960.06 is ON.
- Low-speed jog operation (CCW) will be executed from pulse output 1 while input 2960.07 is ON.

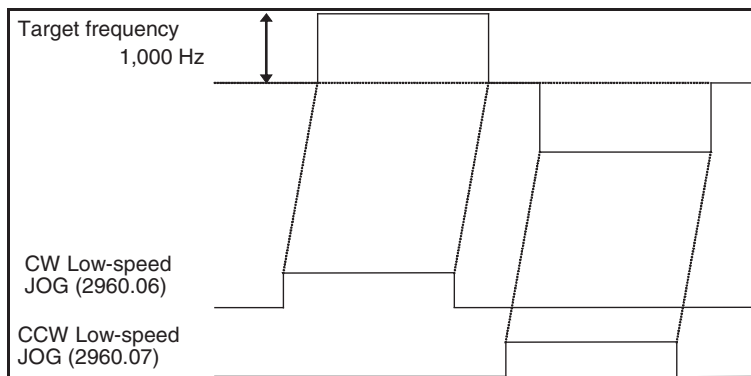

- High-speed job operation (CW) will be executed from pulse output 1 while input 2960.08 is ON.
- High-speed jog operation (CCW) will be executed from pulse output 1 while input 2960.09 is ON.

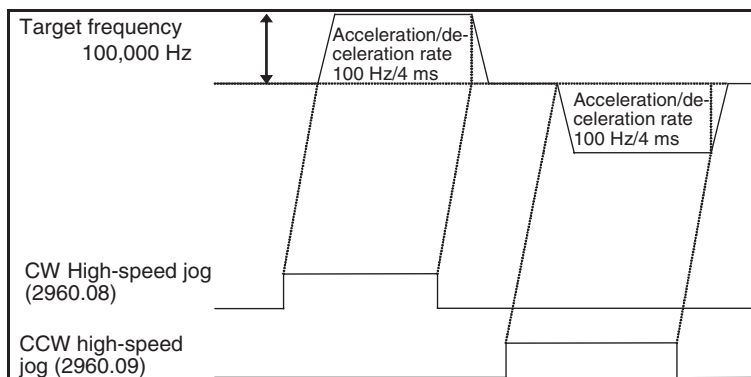

Instructions Used

- SPED(885) Starts and stops (immediate stop) the low-speed jog operations.
- ACC(888) Starts and stops (decelerate to a stop) the high-speed jog operations.

Preparation

PLC Setup Settings

There are no settings that need to be made in the PLC Setup.

DM Area Settings

**Settings to Control Speed while Jogging
(D00000 to D00001 and D00010 to D00015)**

Setting details	Address	Data
Target frequency (low speed): 1,000 Hz	D00000	#03E8
	D00001	#0000
Acceleration rate: 100 Hz/4 ms	D00010	#0064
Target frequency (high speed): 100,000 Hz	D00011	#86A0
	D00012	#0001
Deceleration rate: 100 Hz/4 ms (Not used.)	D00013	#0064
Target frequency (stop): 0 Hz	D00014	#0000
	D00015	#0000

Ladder Program

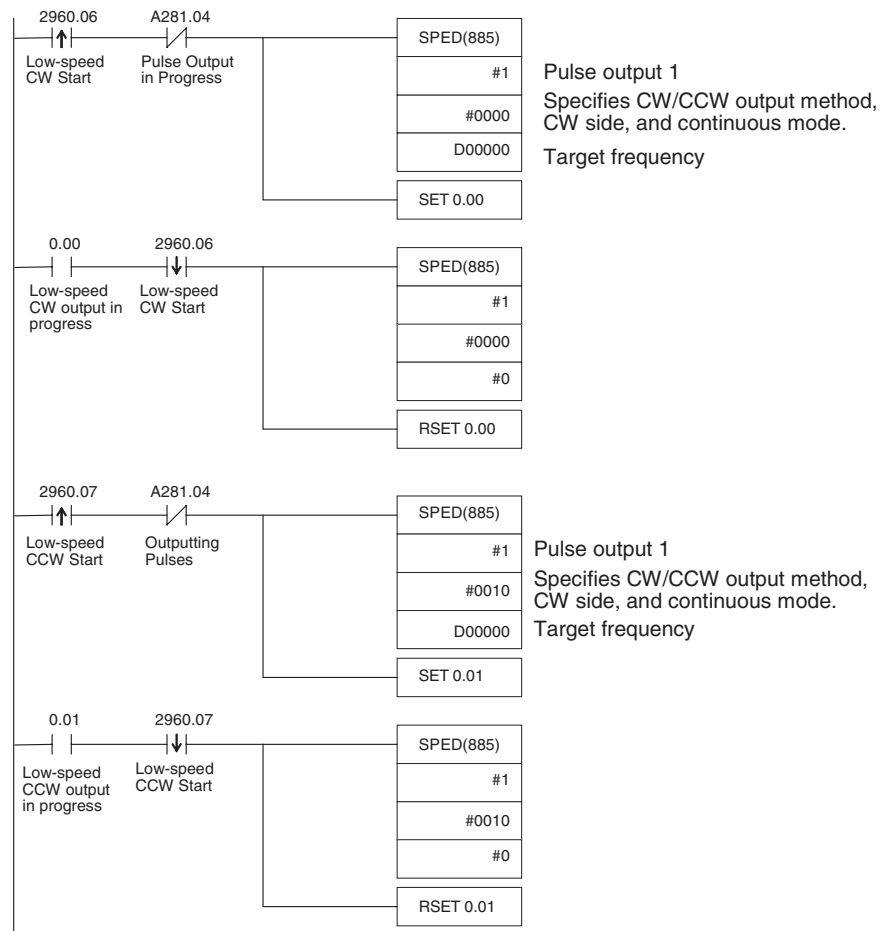

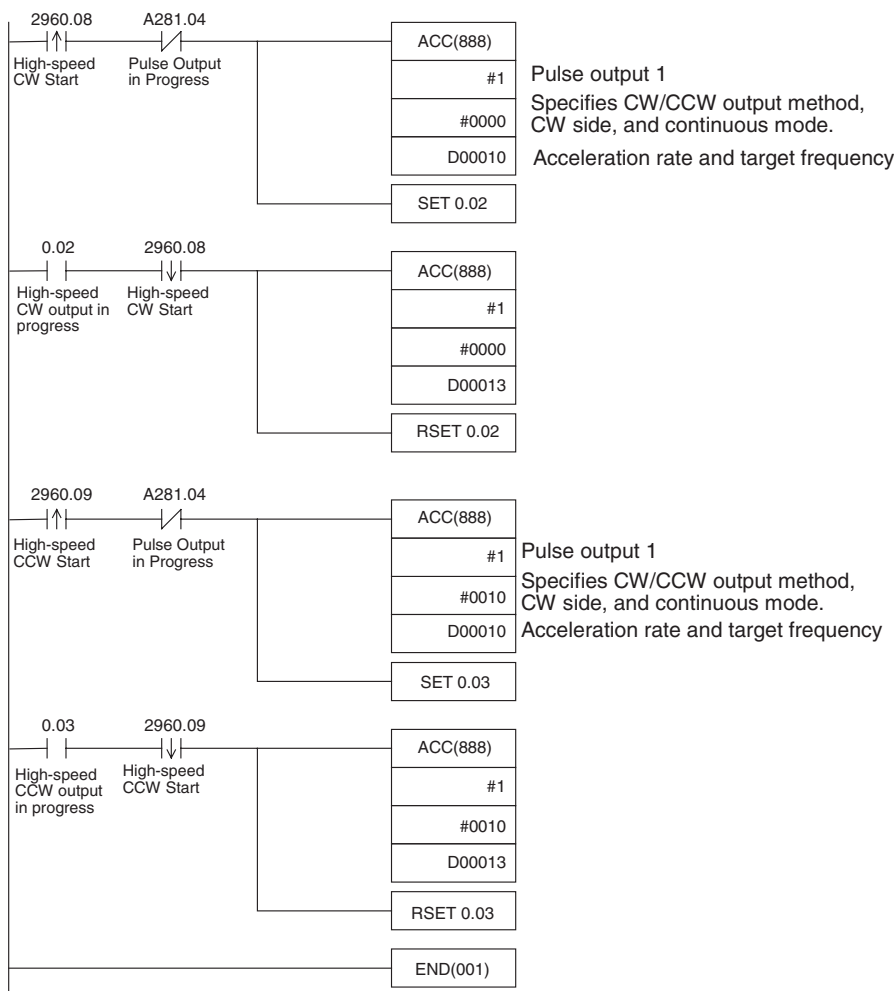

Remarks

PLS2(887) can be used to set a starting frequency or unequal acceleration and deceleration rates, but there are limitations on the operating range because the end point must be specified in PLS2(887).

7-1-5 Cutting Long Material Using Fixed Feeding

Specifications and Operation

Outline

In this example, first jogging is used to position the material and then fixed-distance positioning is used to feed the material.

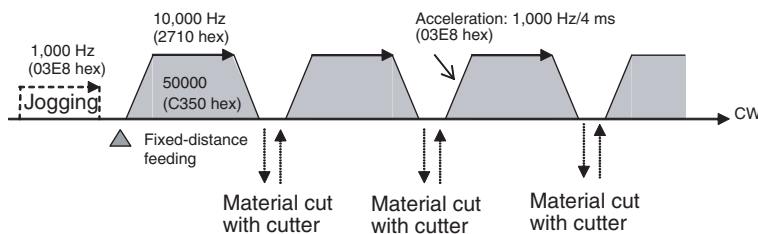

System Configuration

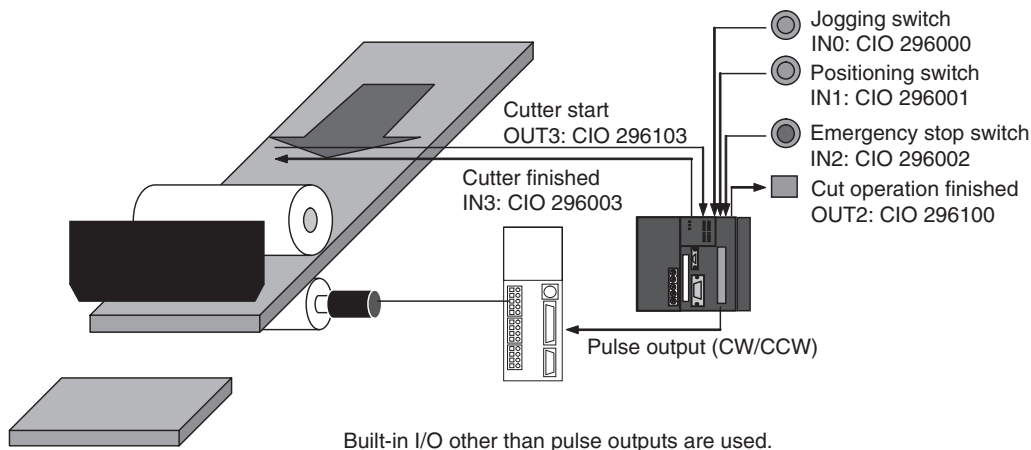

Operation

- 1,2,3...**
1. The workpiece is set at the starting position using the Jogging Switch Input (IN0: CIO 296000).
 2. The workpiece is feed the specified distance (relative) using the Positioning Switch Input (IN1: CIO 296001).
 3. When feeding has been completed, the cutter is activated using the Cutter Start Output (OUT3: CIO 296103).
 4. Feeding is started again when the Cutter Finished Input (IN3: CIO 296003) turns ON.
 5. The feeding/cutting operation is repeated for the number of times specified for the counter (C0, 100 times).
 6. When the operation has been completed, the Cutting Operation Finished Output (OUT2: CIO 296102). is turned ON.

The feeding operation can be canceled and operation stopped at any point using the Emergency Switch Input (IN2: CIO 296002).

Instructions Used

SPED(885)
PLS2(887)

Preparation

PLC Setup Settings

There are no settings that need to be made in the PLC Setup.

DM Area Settings

Speed Settings for Jogging (D00000 to D00003)

Setting details	Address	Data
Target frequency: 1,000 Hz	D00000	#03E8
	D00001	#0000
Target frequency: 0 Hz	D00002	#0000
	D00003	#0000

Settings for PLS2(887) for Fixed-distance Feeding (D00010 to D00020)

Setting details	Address	Data
Acceleration rate: 1,000 Hz/4 ms	D00010	#03E8
Deceleration rate: 1,000 Hz/4 ms	D00011	#03E8

Setting details	Address	Data
Target frequency: 10,000 Hz	D00012	#2710
	D00013	#0000
Number of output pulses: 50,000 pulses	D00014	#C350
	D00015	#0000
Starting frequency: 0000 Hz	D00016	#0000
	D00017	#0000
Counter setting: 100 times	D00020	#0100

Ladder Program

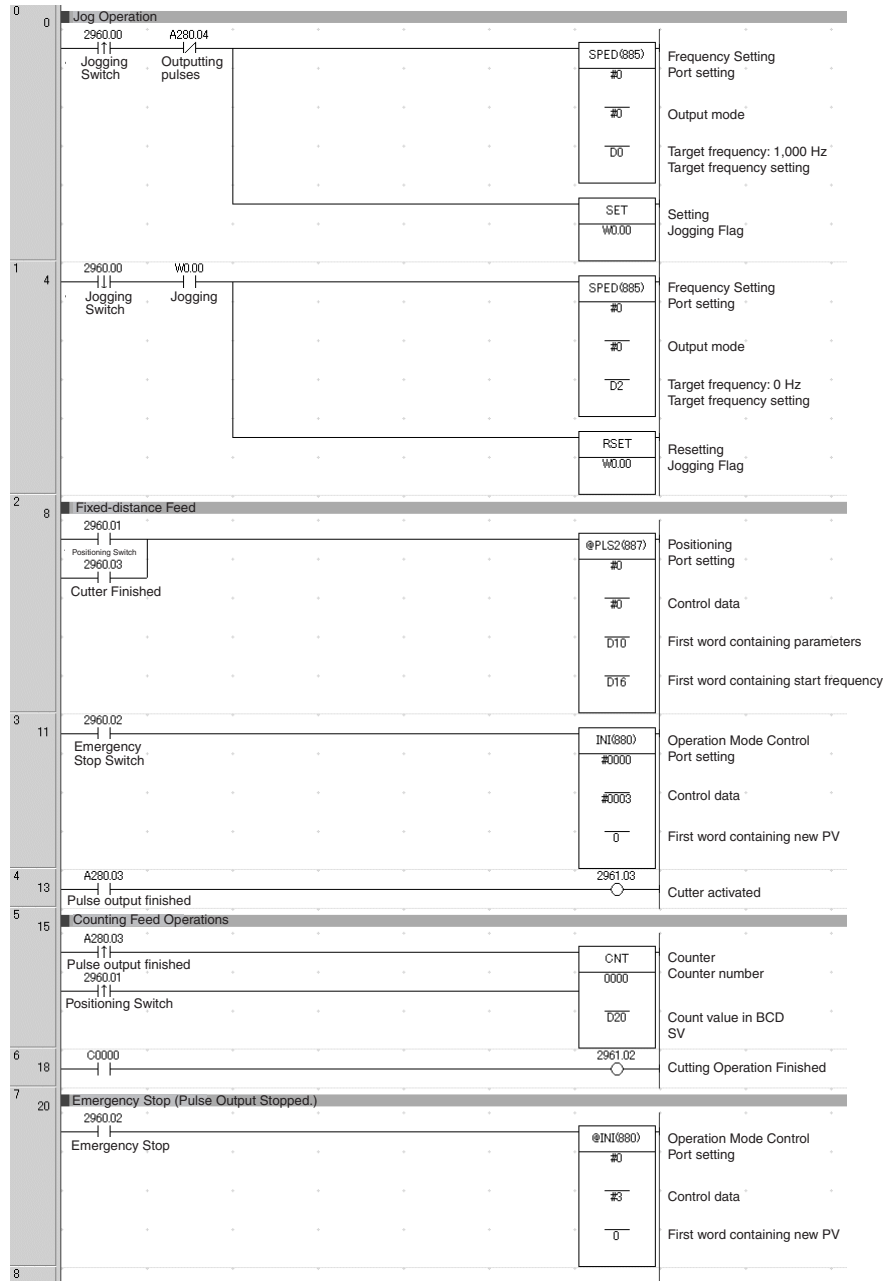

Remarks

- 1,2,3...**
1. PLS22(887) used a relative pulse setting. This enables operation even if the origin is not defined. The present position in A276 (lower 4 digits) and A277 (upper 4 digits) is set to 0 before pulse output and then contains the specified number of pulses.
 2. ACC(888) can be used instead of SPED(885) for the jog operation. If ACC(888) is used, acceleration/deceleration can be included in the jog operation.

7-1-6 Vertically Conveying PCBs (Multiple Progressive Positioning)**Specifications and Operation****Outline**

- 1,2,3...**
1. PCBs with components mounted are stored in a stoker.
 2. When a stoker becomes full, it is moved to the conveyance point.

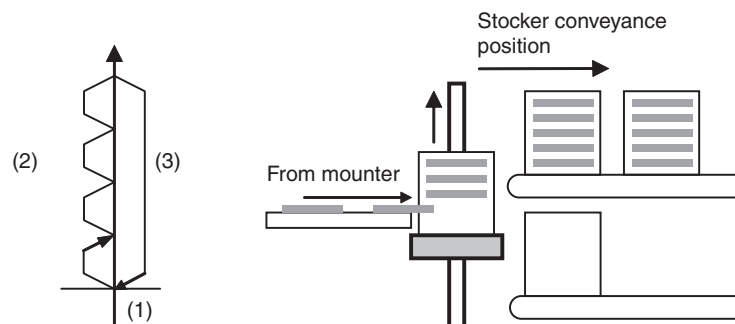
Positioning Operation for Vertical Conveyor**Operation Pattern**

- 1,2,3...**
1. An origin search is performed.
 2. Fix-length positioning is repeated.

3. The system is returned to the original position.

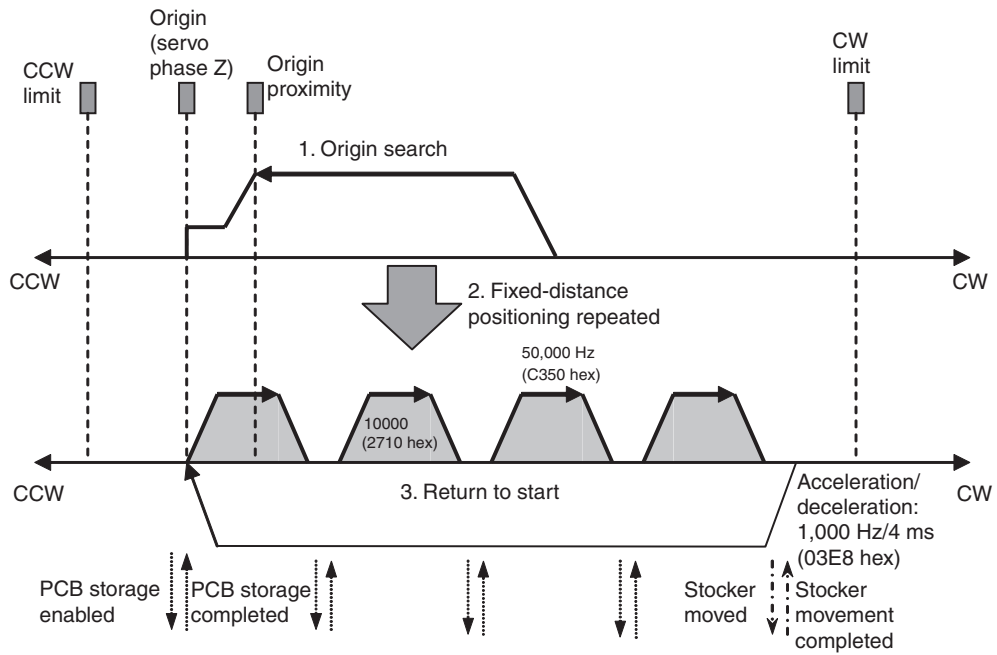

Wiring Example Using SmartStep A-series Servo Driver, XW2Z Cables, and XW2B I/O Terminal

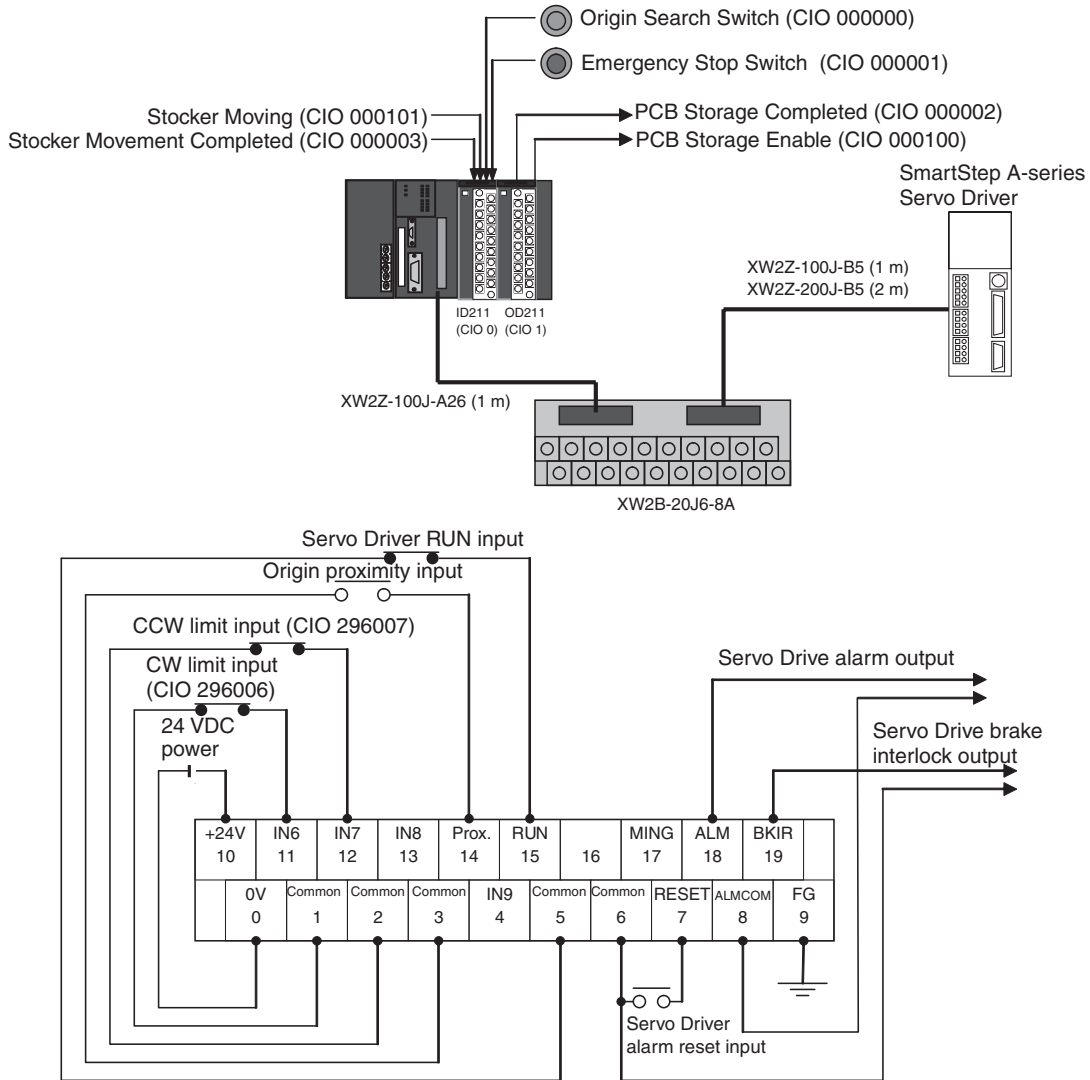

Operation

- 1,2,3...**
1. An origin search is performed using the Origin Search Switch (CIO 000000).
 2. When the origin search is finished, the PCB Storage Enabled Output (CIO 000100) is turned ON.
 3. When a PCB has been stored, the stocker is raised (relative positioning) using the PCB Storage Completed Input (CIO 000002)
 4. Storing PCBs is repeated until the stocker is full.
 5. The number of PCBs in the stocker is counted with counter C0 by counting the number of times the stocker is raised.
 6. When the stocker is full, it is moved (CIO 000101) and only the conveyor is lowered (absolute positioning) when stoker movement is completed (CIO 000003).

The operation can be canceled and pulse output stopped at any point using the Emergency Switch Input (IN2: CIO 000001).

Preparation

PLC Setup Settings

Setting details	Address	Data
Enable origin search function for pulse output 0.	256	0001 hex

Note The origin search enable setting is read when the power supply is turned ON.

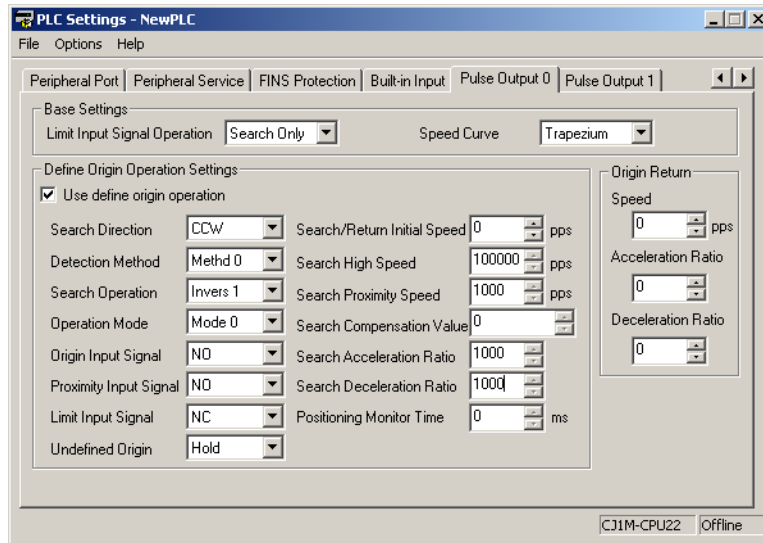

DM Area Settings

Settings for PLS2(887) for Fixed-distance Positioning (D00000 to D00007)

Setting details	Address	Data
Acceleration rate: 1,000 Hz/4 ms	D00000	#03E8
Deceleration rate: 1,000 Hz/4 ms	D00001	#03E8
Target frequency: 50,000 Hz	D00002	#C350
	D00003	#0000
Number of output pulses: 10,000 pulses	D00004	#2710
	D00005	#0000
Starting frequency: 0 Hz	D00006	#0000
	D00007	#0000

Settings for PLS2(887) to Return to Start (D00010 to D00017)

Setting details	Address	Data
Acceleration rate: 300 Hz/4 ms	D00010	#012C
Deceleration rate: 200 Hz/4 ms	D00011	#00C8
Target frequency: 50,000 Hz	D00012	#C350
	D00013	#0000
Number of output pulses: 10,000 × 15 pulses	D00014	#0000
	D00015	#0000
Starting frequency: 100 Hz	D00016	#0000
	D00017	#0000

Number of Repeats of Fixed-distance Positioning Operation (D00020)

Setting details	Address	Data
Number of repeats of fixed-distance positioning operation (number of PCBs in stocker)	D00020	#0015

Ladder Program

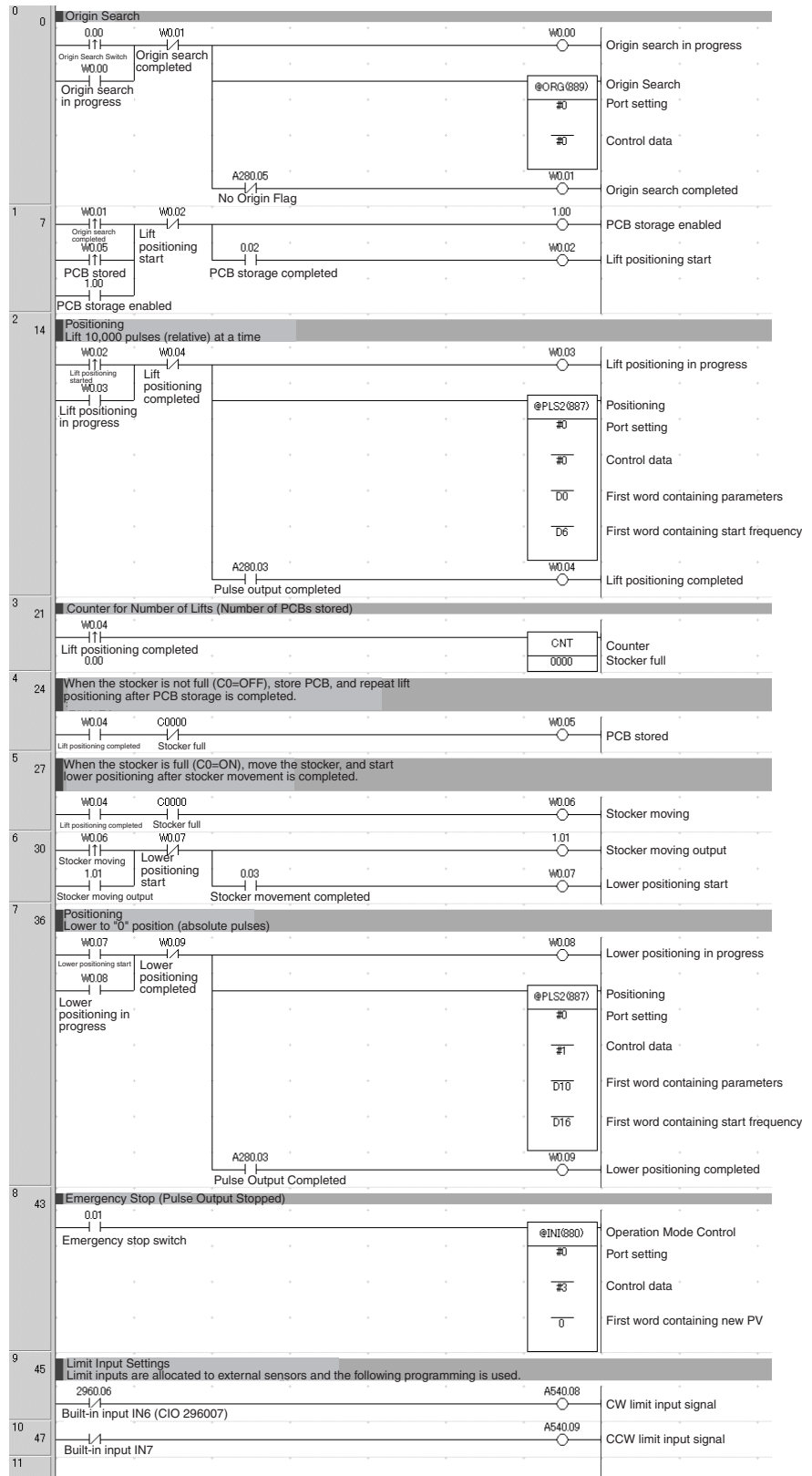

7-1-7 Palletize: Two-axis Multipoint Positioning

Specifications and Operation

Outline

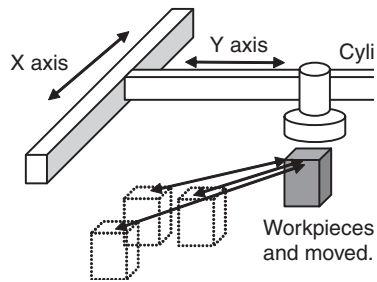

Operation Pattern

- 1,2,3... 1. An origin search is performed.
 2. A workpiece is grasped and moved to position A.
 3. The workpiece is grasped and moved to the assembly positions.

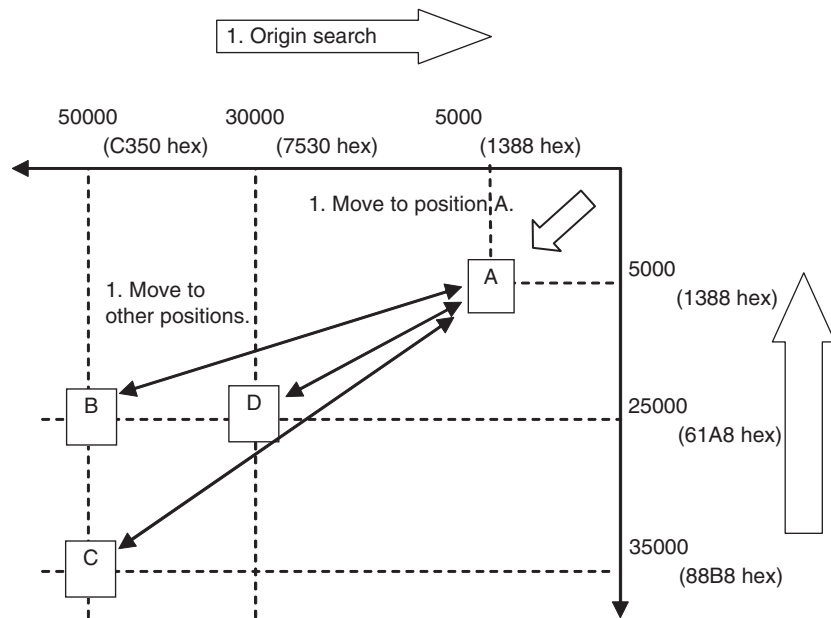

Note The X and Y axes are moved independently, i.e., interpolation is not performed.

Wiring Example Using SmartStep A-series Servo Driver, XW2Z Cables, and XW2B I/O Terminal

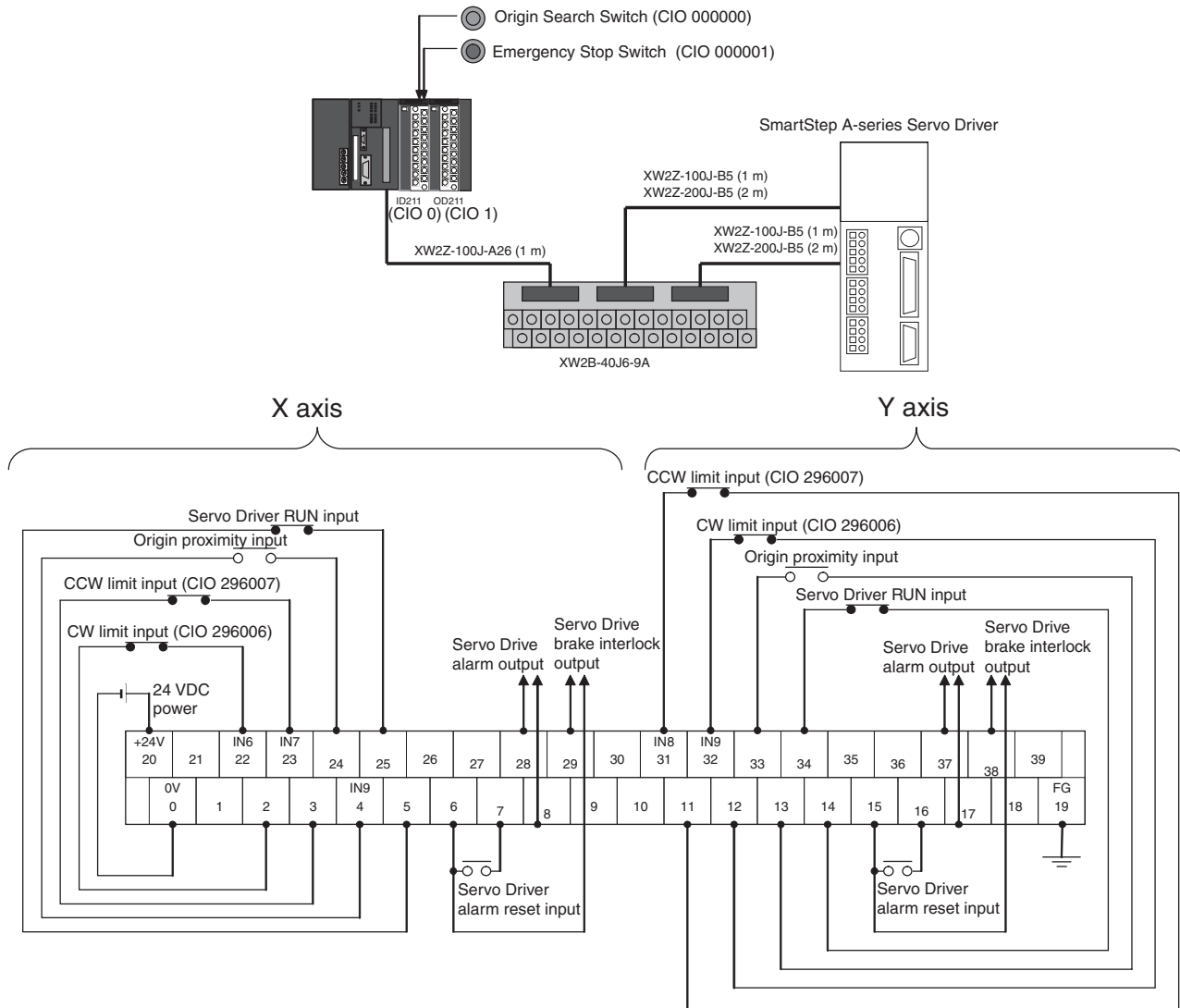

Operation

- 1,2,3...**
- An origin search is performed using the Origin Search Switch (CIO 000000).
 - When the origin search is finished, the following operations are performed continuously.
 - Move to A.
 - Move to B and return to A.
 - Move to C and return to A.
 - Move to D and return to A.
 - An emergency stop can be performed using the Emergency Stop Input (CIO 000001)

Preparation

PLC Setup Settings

CX-Programmer version	Tab name	Setting
Ver. 3.1 or lower	Define Origin Operation Settings Field of Define Origin	Origin search data
Ver. 3.2 or higher	Pulse Output 0	Origin search data

Note The *Use Origin Operation Setting* is read when the power supply is turned ON.

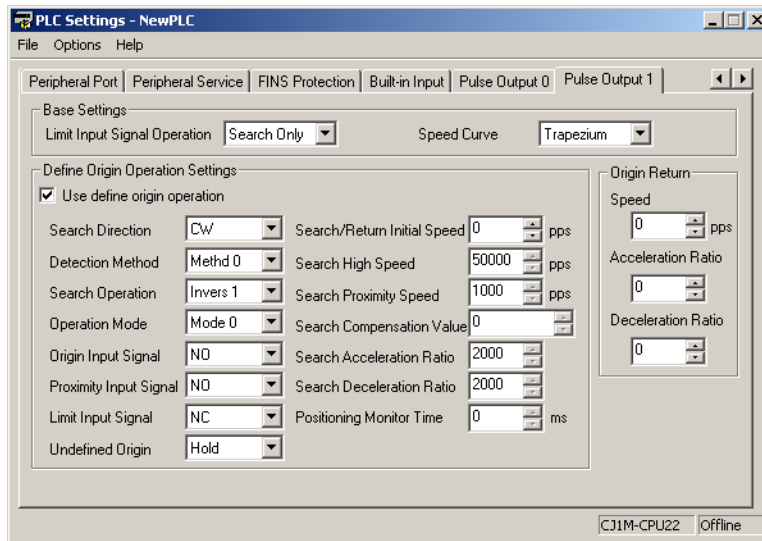
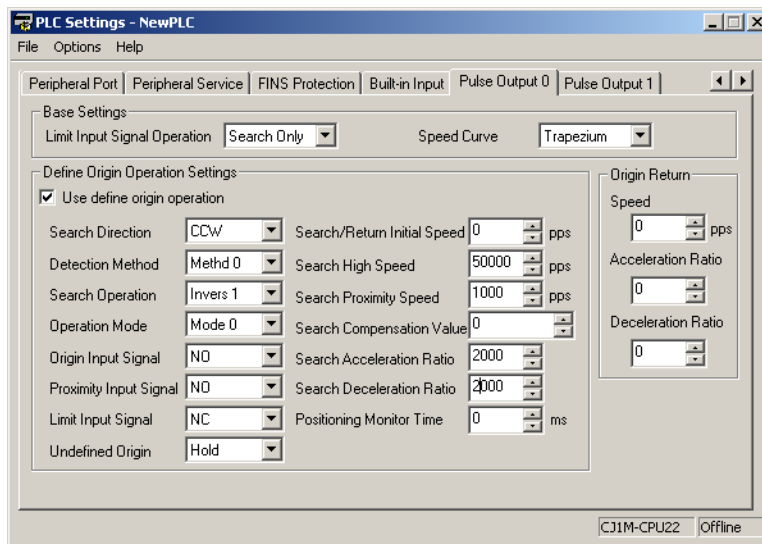

DM Area Settings

Starting Frequency

Setting details	Address	Data
X-axis starting frequency	D00000	#0000
Y-axis starting frequency	D00002	#0000

PLS2(887) Settings to Move from Origin to Position A

Setting details		Address	Data
X axis	Acceleration rate: 2,000 Hz/4 ms	D00010	#07D0
	Deceleration rate: 2,000 Hz/4 ms	D00011	#07D0
	Target frequency: 100,000 Hz	D00012	#86A0
		D00013	#0001
	Number of output pulses: 5,000 pulses	D00014	#1388
D00015		#0000	
Y axis	Acceleration rate: 2,000 Hz/4 ms	D00020	#07D0
	Deceleration rate: 2,000 Hz/4 ms	D00021	#07D0
	Target frequency: 100,000 Hz	D00022	#86A0
		D00023	#0001
	Number of output pulses: 5,000 pulses	D00024	#1388
D00025		#0000	

PLS2(887) Settings to Move from Position A to Position B

Setting details		Address	Data
X axis	Acceleration rate: 2,000 Hz/4 ms	D00030	#07D0
	Deceleration rate: 2,000 Hz/4 ms	D00031	#07D0
	Target frequency: 100,000 Hz	D00032	#86A0
		D00033	#0001
	Number of output pulses: 25,000 pulses	D00034	#61A8
D00035		#0000	
Y axis	Acceleration rate: 2,000 Hz/4 ms	D00040	#07D0
	Deceleration rate: 2,000 Hz/4 ms	D00041	#07D0
	Target frequency: 100,000 Hz	D00042	#86A0
		D00043	#0001
	Number of output pulses: 50,000 pulses	D00044	#C350
D00045		#0000	

PLS2(887) Settings to Move from Position A to Position C

Setting details		Address	Data
X axis	Acceleration rate: 2,000 Hz/4 ms	D00050	#07D0
	Deceleration rate: 2,000 Hz/4 ms	D00051	#07D0
	Target frequency: 100,000 Hz	D00052	#86A0
		D00053	#0001
	Number of output pulses: 35,000 pulses	D00054	#88B8
D00055		#0000	
Y axis	Acceleration rate: 2,000 Hz/4 ms	D00060	#07D0
	Deceleration rate: 2,000 Hz/4 ms	D00061	#07D0
	Target frequency: 100,000 Hz	D00062	#86A0
		D00063	#0001
	Number of output pulses: 50,000 pulses	D00064	#C350
D00065		#0000	

PLS2(887) Settings to Move from Position A to Position D

Setting details		Address	Data
X axis	Acceleration rate: 2,000 Hz/4 ms	D00070	#07D0
	Deceleration rate: 2,000 Hz/4 ms	D00071	#07D0
	Target frequency: 100,000 Hz	D00072	#86A0
		D00073	#0001
	Number of output pulses: 25,000 pulses	D00074	#61A8
D00075		#0000	
Y axis	Acceleration rate: 2,000 Hz/4 ms	D00080	#07D0
	Deceleration rate: 2,000 Hz/4 ms	D00081	#07D0
	Target frequency: 100,000 Hz	D00082	#86A0
		D00083	#0001
	Number of output pulses: 30,000 pulses	D00084	#7530
D00085		#0000	

Ladder Program

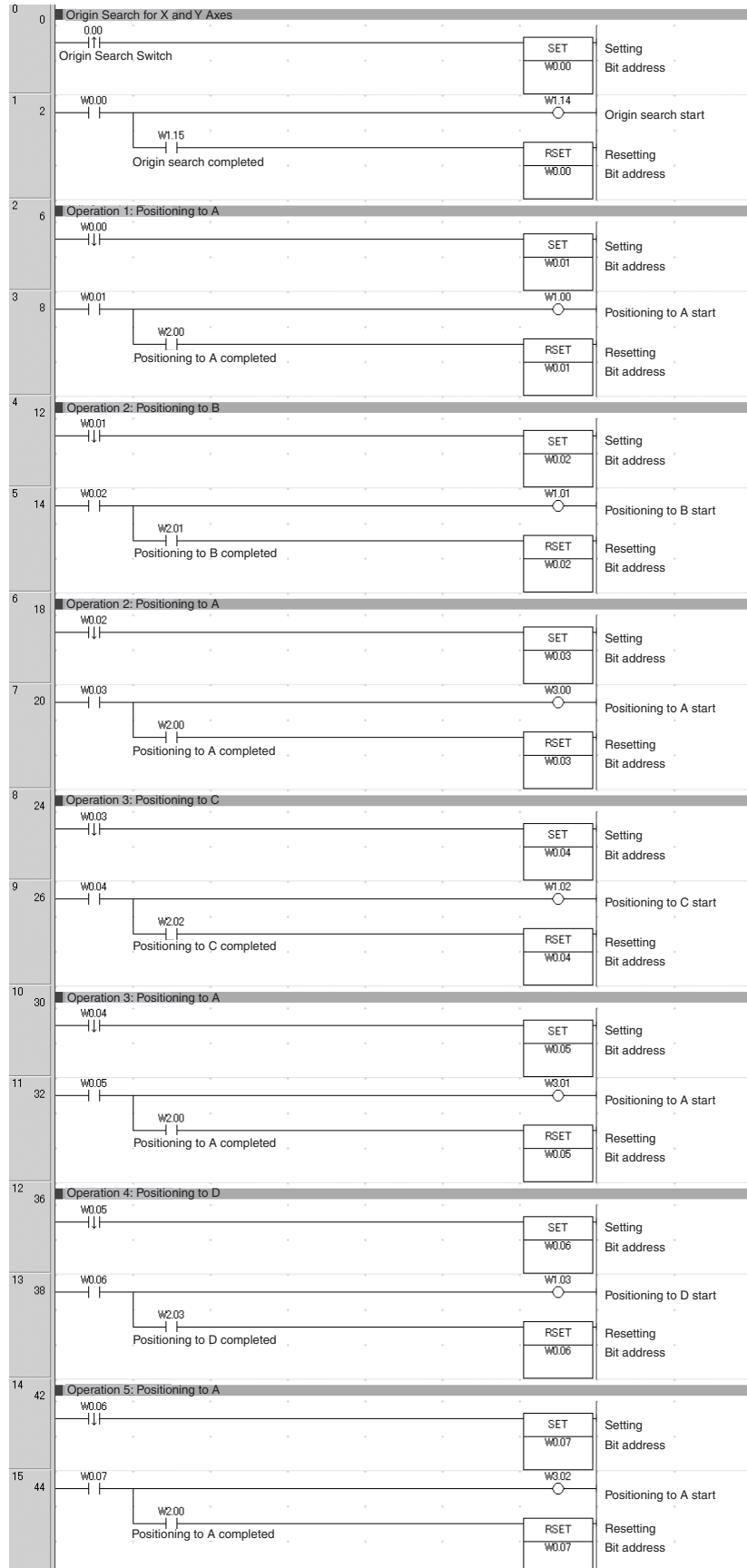

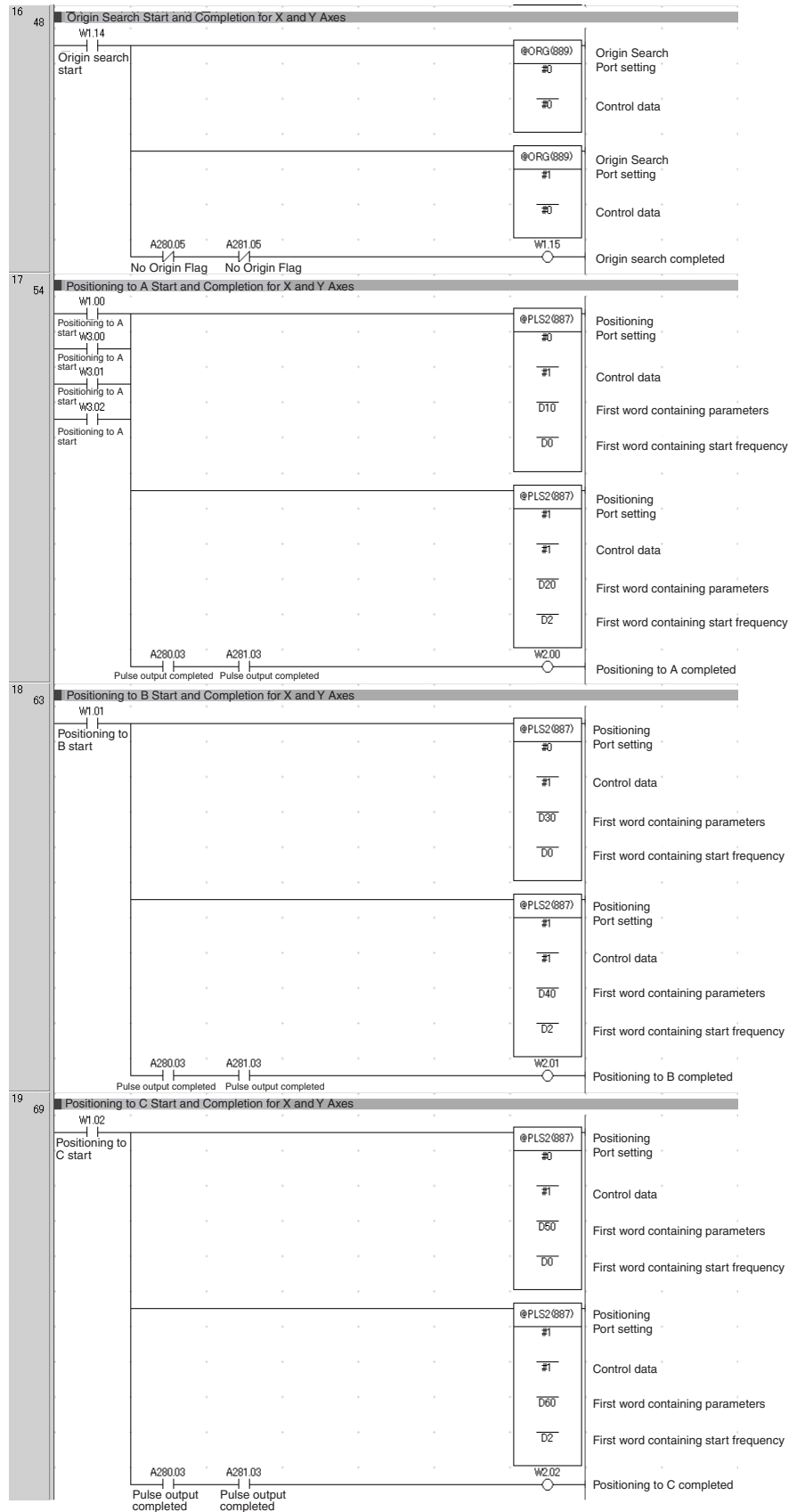

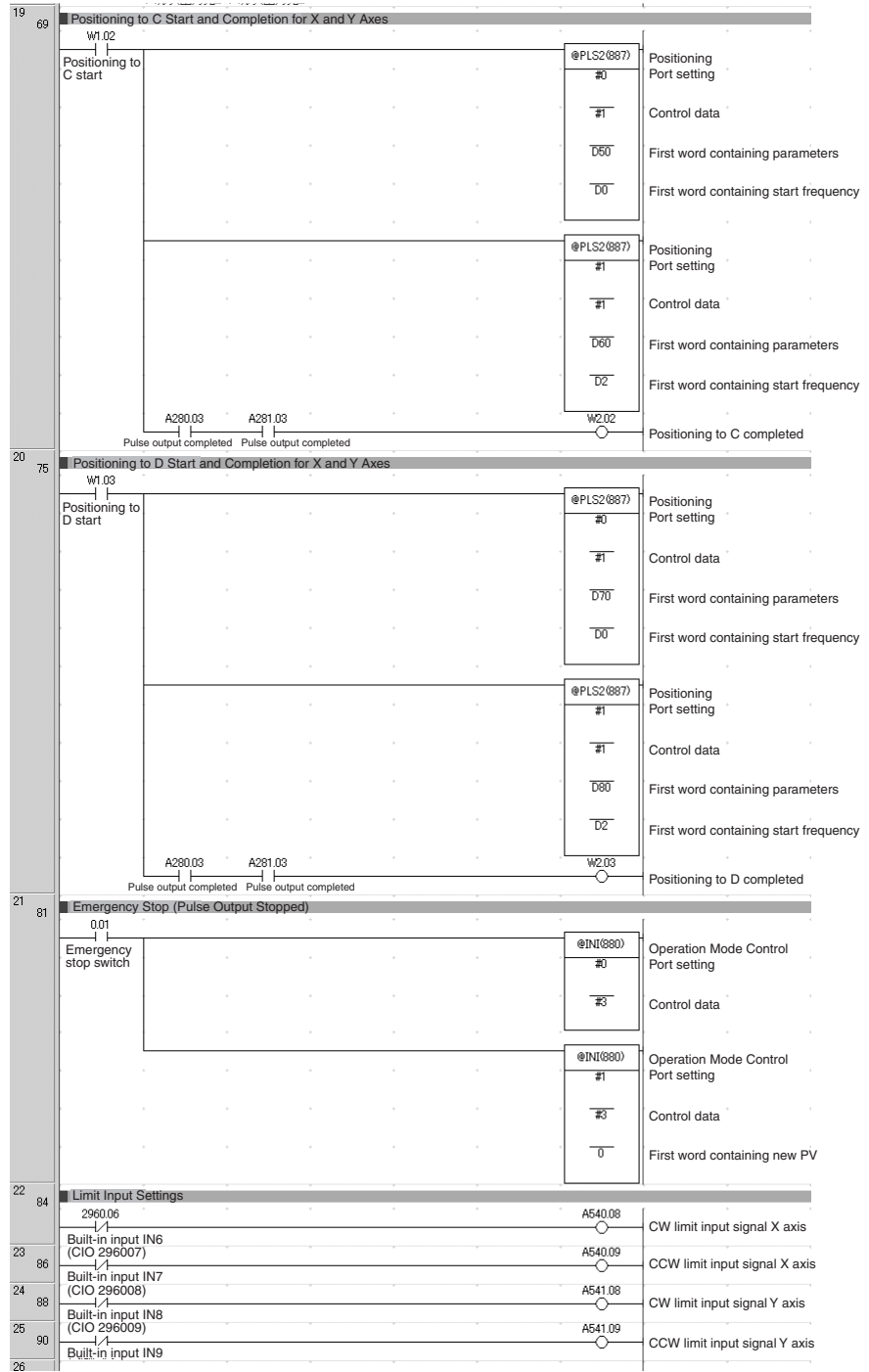

7-1-8 Feeding Wrapping Material: Interrupt Feeding

Specifications and Operation

Feeding Wrapping Material in a Vertical Pillow Wrapper

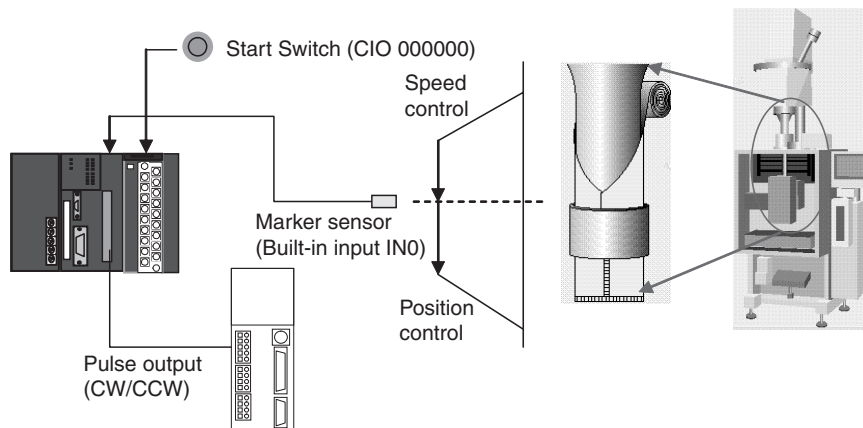

Operation Pattern

Speed control is used to feed wrapping material to the initial position. When the marker sensor input is received, fixed-distance positioning is performed before stopping.

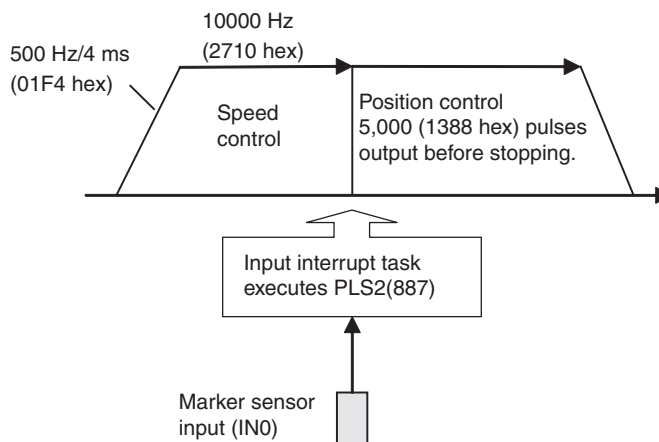

Operation

- 1,2,3...**
1. Speed control is used to feed wrapping material to the initial position when the Start Switch (CIO 00000) is activated.
 2. When the Marker Sensor Input (IN0) is received, PLS2(887) is executed in interrupt task 140.
 3. Fixed-distance positioning is executed with PLS2(887) before stopping.

Preparation

PLC Setup Settings

Setting details	Address	Data
Enable using built-in input IN0 as an interrupt input.	060	0011 hex

Note The interrupt input setting is read when the power supply is turned ON.

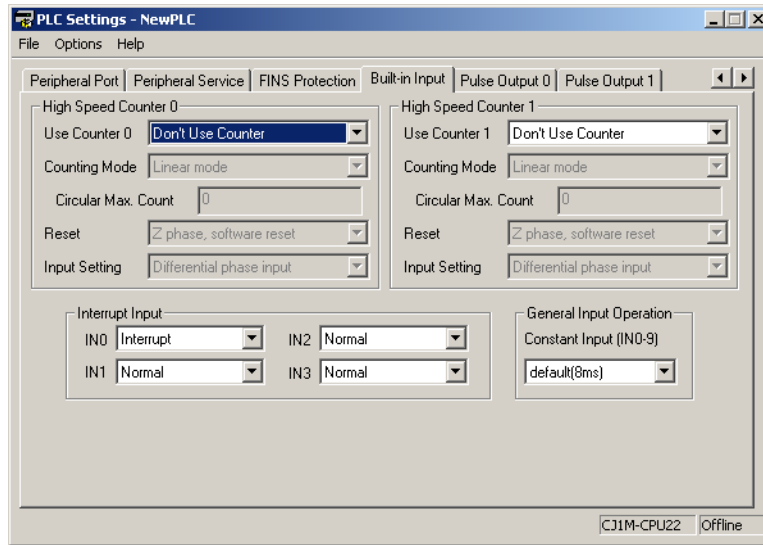

DM Area Settings

Speed Control Settings to Feed Wrapping Material to Initial Position

Setting details	Address	Data
Acceleration rate: 500 Hz/4 ms	D00000	#01F4
Target frequency: 10,000 Hz	D00001	#2710
	D00002	#0000

Positioning Control Settings for Wrapping Material

Setting details	Address	Data
Acceleration rate: 500 Hz/4 ms	D00010	#01F4
Deceleration rate: 500 Hz/4 ms	D00011	#01F4
Target frequency: 10,000 Hz	D00012	#2710
	D00013	#0000
Number of output pulses: 5,000 pulses	D00014	#1388
	D00015	#0000
Starting frequency: 0 Hz	D00016	#0000
	D00017	#0000

Ladder Program

Cyclic Task Program (Executed at Startup)

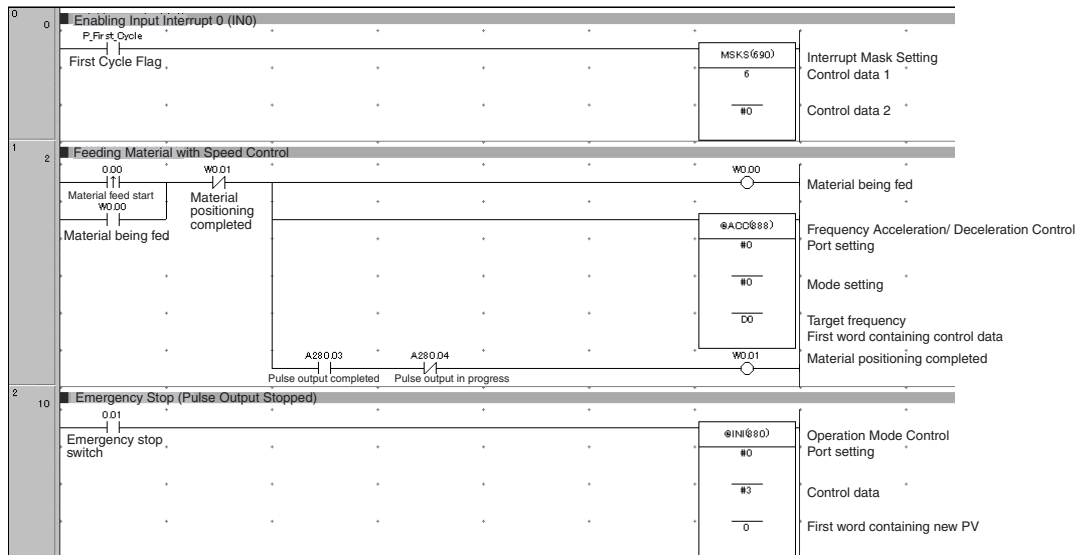

Program for Interrupt Task 140

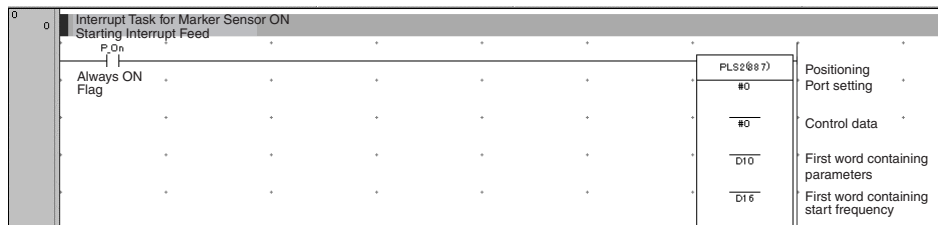

Appendix A

Combinations of Pulse Control Instructions

Starting Instructions: SPED(885) and ACC(888), Independent

Instruction being executed	Pulse status	Starting instruction							
		INI(880)		SPED(885) (Independent)		SPED(885) (Continuous)		ACC(888) (Independent)	
SPED(885) (Independent)	Steady speed	Change PV	×	Output method	---	Output method	×	Output method	---
		Stop pulses	○	Direction	---	Direction	×	Direction	---
		---	---	Target frequency	○	Target frequency	×	Target frequency	○
		---	---	---	---	---	---	Acceleration/deceleration rate	○
SPED(885) (Continuous)	Steady speed	Change PV	×	Output method	×	Output method	---	Output method	×
		Stop pulses	○	Direction	×	Direction	---	Direction	×
		---	---	Target frequency	×	Target frequency	○	Target frequency	×
		---	---	---	---	---	---	Acceleration/deceleration rate	×
ACC(888) (Independent)	Steady speed	Change PV	×	Output method	×	Output method	×	Output method	---
		Stop pulses	○	Direction	×	Direction	×	Direction	---
		---	---	Target frequency	×	Target frequency	×	Target frequency	○
		---	---	---	---	---	---	Acceleration/deceleration rate	○
	Accelerating or decelerating	Change PV	×	Output method	×	Output method	×	Output method	---
		Stop pulses	○	Direction	×	Direction	×	Direction	---
		---	---	Target frequency	×	Target frequency	×	Target frequency	○
		---	---	---	---	---	---	Acceleration/deceleration rate	○
ACC(888) (Continuous)	Steady speed	Change PV	×	Output method	×	Output method	×	Output method	×
		Stop pulses	○	Direction	×	Direction	×	Direction	×
		---	---	Target frequency	×	Target frequency	×	Target frequency	×
		---	---	---	---	---	---	Acceleration/deceleration rate	×
	Accelerating or decelerating	Change PV	×	Output method	×	Output method	×	Output method	×
		Stop pulses	○	Direction	×	Direction	×	Direction	×
		---	---	Target frequency	×	Target frequency	×	Target frequency	×
		---	---	---	---	---	---	Acceleration/deceleration rate	×
PLS2(887)	Steady speed	Change PV	×	Output method	×	Output method	×	Output method	---
		Stop pulses	○	Direction	×	Direction	×	Direction	---
		---	---	Target frequency	×	Target frequency	×	Target frequency	○
		---	---	---	---	---	---	Acceleration/deceleration rate	○
	Accelerating or decelerating	Change PV	×	Output method	×	Output method	×	Output method	---
		Stop pulses	○	Direction	×	Direction	×	Direction	---
		---	---	Target frequency	×	Target frequency	×	Target frequency	○
		---	---	---	---	---	---	Acceleration/deceleration rate	○

Instruction being executed	Pulse status	Starting instruction							
		INI(880)		SPED(885) (Independent)		SPED(885) (Continuous)		ACC(888) (Independent)	
ORG(889)	Steady speed	Change PV	×	Output method	×	Output method	×	Output method	×
		Stop pulses	○	Direction	×	Direction	×	Direction	×
		---	---	Target frequency	×	Target frequency	×	Target frequency	×
		---	---	---	---	Acceleration/deceleration rate	---	Acceleration/deceleration rate	×
	Accelerating or decelerating	Change PV	×	Output method	×	Output method	×	Output method	×
		Stop pulses	○	Direction	×	Direction	×	Direction	×
		---	---	Target frequency	×	Target frequency	×	Target frequency	×
		---	---	---	---	Acceleration/deceleration rate	---	Acceleration/deceleration rate	×

○: Can be executed., ×: Instruction Error will occur. (Error Flag ON), ---: Ignored. (Instruction error won't occur.)

Starting Instructions: ACC(888), Continuous, PLS2(887), and ORG(889)

Instruction being executed	Pulse status	Starting instruction					
		ACC(888) (Continuous)		PLS2(887)		ORG(889)	
SPED(885) (Independent)	Steady speed	Output method	×	Output method	×	Output method	×
		Direction	×	Frequency/Acceleration	×	Search or return	×
		Target frequency	×	Position/Movement data	×	---	---
		Acceleration/deceleration rate	×	Starting frequency	×	---	---
SPED(885) (Continuous)	Steady speed	Output method	---	Output method	×	Output method	×
		Direction	---	Frequency/Acceleration	×	Search or return	×
		Target frequency	○	Position/Movement data	×	---	---
		Acceleration/deceleration rate	○	Starting frequency	×	---	---
ACC(888) (Independent)	Steady speed	Output method	×	Output method	---	Output method	×
		Direction	×	Frequency/Acceleration	○	Search or return	×
		Target frequency	×	Position/Movement data	○	---	---
		Acceleration/deceleration rate	×	Starting frequency	---	---	---
	Accelerating or decelerating	Output method	×	Output method	---	Output method	×
		Direction	×	Frequency/Acceleration	○	Search or return	×
		Target frequency	×	Position/Movement data	○	---	---
		Acceleration/deceleration rate	×	Starting frequency	---	---	---
ACC(888) (Continuous)	Steady speed	Output method	---	Output method	---	Output method	×
		Direction	---	Frequency/Acceleration	○	Search or return	×
		Target frequency	○	Position/Movement data	○	---	---
		Acceleration/deceleration rate	○	Starting frequency	---	---	---
	Accelerating or decelerating	Output method	---	Output method	---	Output method	×
		Direction	---	Frequency/Acceleration	○	Search or return	×
		Target frequency	×	Position/Movement data	○	---	---
		Acceleration/deceleration rate	×	Starting frequency	---	---	---
PLS2(886)	Steady speed	Output method	×	Output method	---	Output method	×
		Direction	×	Frequency/Acceleration	○	Search or return	×
		Target frequency	×	Position/Movement data	○	---	---
		Acceleration/deceleration rate	×	Starting frequency	---	---	---
	Accelerating or decelerating	Output method	×	Output method	---	Output method	×
		Direction	×	Frequency/Acceleration	○	Search or return	×
		Target frequency	×	Position/Movement data	○	---	---
		Acceleration/deceleration rate	×	Starting frequency	---	---	---
ORG(889)	Steady speed	Output method	×	Output method	×	Output method	×
		Direction	×	Frequency/Acceleration	×	Search or return	×
		Target frequency	×	Position/Movement data	×	---	---
		Acceleration/deceleration rate	×	Starting frequency	×	---	---
	Accelerating or decelerating	Output method	×	Output method	×	Output method	×
		Direction	×	Frequency/Acceleration	×	Search or return	×
		Target frequency	×	Position/Movement data	×	---	---
		Acceleration/deceleration rate	×	Starting frequency	×	---	---

○: Can be executed., ×: Instruction error will occur. (Error Flag ON), ---: Ignored. (Instruction error won't occur.)

Appendix B

Using Pulse Instructions in other CPU Units

PLC Compatibility Table

Instruction	Function	CJ1M	CQM1H	CPM2C	Customizable Counter Units
PULS(886)	Specifying the number of output pulses (absolute or relative)	○	---	○	○
	Specifying the CW/CCW direction	---	○	---	---
	Using PULS(886) independently to output pulses (absolute position pulse output)	---	---	---	○
SPED(885)	Changing the frequency during pulse output	○	○	○	○
	Switching between CW/CCW and Pulse + direction output methods	○	---	---	---
ACC(88*)	Trapezoidal pulse control (equal acceleration and deceleration rates)	○	○	○	---
	Setting different acceleration and deceleration rates	---	○	---	---
	Changing the frequency during pulse output ACC(888) (independent) →ACC(888) (independent) or ACC(888) (continuous) →ACC(888) (continuous)	○	○ (Independent mode only)	○ (Cannot be executed during acceleration or deceleration.)	○ (Cannot be executed during acceleration or deceleration.)
	Changing the frequency during pulse output PLS2(887) →ACC(888) (independent)	○	---	---	---
	Changing the acceleration/deceleration rate during pulse output ACC(888) (independent) →ACC(888) (independent) or ACC(888) (continuous) →ACC(888) (continuous)	○	○ (Independent mode only)	○ (Cannot be executed during acceleration or deceleration.)	○ (Cannot be executed during acceleration or deceleration.)
	Changing the acceleration/deceleration rate during pulse output PLS2(887) →ACC(888) (independent)	○	---	---	---
	Switching between CW/CCW and Pulse + direction output methods	○	---	---	---

Instruction	Function	CJ1M	CQM1H	CPM2C	Customizable Counter Units
PLS2(887)	Specifying the number of output pulses (absolute or relative)	○	---	--- (Instruction not supported)	○
	Switching between CW/CCW and Pulse + direction output methods	○	---	--- (Instruction not supported)	---
	Setting different acceleration and deceleration rates	○	---	--- (Instruction not supported)	○
	Changing the number of output pulses (target position) during pulse output PLS2(887) → PLS2(887)	○	---	--- (Instruction not supported)	---
	Changing the frequency during pulse output ACC(888) (independent) PLS2(887) Or ACC(888) (Continuous) PLS2(887) Or PLS2(887) → PLS2(887)	○	---	--- (Instruction not supported)	---
	Changing the acceleration rate and deceleration rate during pulse output ACC(888) (independent) PLS2(887) Or ACC(888) (Continuous) PLS2(887) Or PLS2(887) → PLS2(887)	○	---	--- (Instruction not supported)	---
PWM(891)	Changing the duty ratio during pulse output	○	○	○	○
	Setting the pulse frequency in 0.1-Hz units	○	×	×	×
ORG(889)	Performing origin search and origin return operations	○	--- (Instruction not supported)	--- (Instruction not supported)	--- (Instruction not supported)
CTBL(882)	Comparing PV with comparison table	High-speed counter PV only	High-speed counter PV only	High-speed counter PV only	•High-speed counter PV •Pulse output PV
INI(880)	Changing PVs (PVs that can be changed.)	•High-speed counter PV •Interrupt input (counter mode) PV •Pulse output PV	•High-speed counter PV	•High-speed counter PV •Interrupt input (counter mode) PV •Pulse output PV	•High-speed counter PV •Pulse output PV

Instruction	Function	CJ1M	CQM1H	CPM2C	Customizable Counter Units
PRV(881)	Reading PVs (PVs that can be read.)	<ul style="list-style-type: none"> •High-speed counter PV •Interrupt input (counter mode) PV •Pulse input frequency •Pulse output frequency •Pulse output PV 	<ul style="list-style-type: none"> •High-speed counter PV 	<ul style="list-style-type: none"> •High-speed counter PV •Interrupt input (counter mode) PV •Input frequency •Pulse output PV 	<ul style="list-style-type: none"> •High-speed counter PV •Pulse output PV
	Reading pulse output status (Data read.)	<ul style="list-style-type: none"> •Pulse output status •PV overflow and underflow •Number of output pulses setting •Pulse Output Completed or Pulse Output in Progress •No-origin Flag •At-origin Flag 	<ul style="list-style-type: none"> •Deceleration set/not set •Number of output pulses set/not set •Pulse output complete/not complete •Pulse output stopped/in progress •Comparison operation stopped/in progress •Overflow/underflow 	<ul style="list-style-type: none"> •Deceleration set/not set •Number of output pulses set/not set •Pulse output complete/not complete •Pulse output stopped/in progress •Comparison operation stopped/in progress •Overflow/underflow 	×
	Reading high-speed counter status (Data read.)	<ul style="list-style-type: none"> •Range comparison results •Comparison operation •Overflow/underflow 	Same as pulse output status data above	Same as pulse output status data above	×

Appendix C

Interrupt Response Times

Note The actual performance depends on a variety of factors that affect CPU Unit operation such as the function's operating conditions, user program complexity, and cycle time. Use the performance specifications as guidelines, not absolute values.

Built-in Interrupt Input Response Time

The interrupt response time is the time it takes between an OFF-to-ON signal (or ON-to-OFF signal for down-differentiation) at the built-in interrupt input terminal until the corresponding I/O interrupt task is actually executed. The total response time is the sum of the hardware response time and software response time.

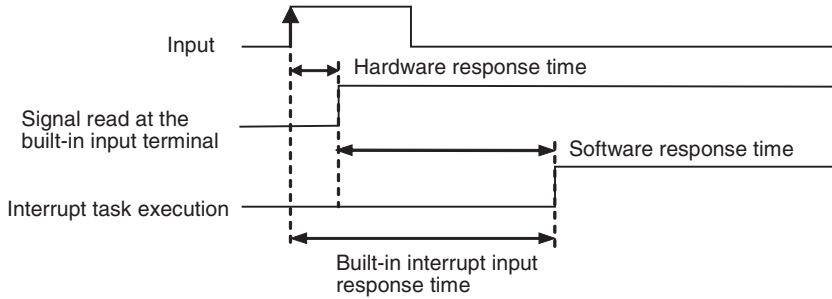

Built-in interrupt input response time = Hardware interrupt response time + Software interrupt response time

Item	CJ1M-CPU22/23		CJ1M-CPU21	
	Interrupt response time	Counter interrupts	Interrupt response time	Counter interrupts
Hardware interrupt response time	Up-differentiation 30 μ s	---	Up-differentiation 30 μ s	---
	Down-differentiation 150 μ s	---	Down-differentiation 150 μ s	---
Software interrupt response time	Minimum: 93 μ s	Maximum: 203 μ s + α	Minimum: 159 μ s	187 μ s
	Maximum: 209 μ s + α (See note.)	Minimum: 103 μ s	Maximum: 289 μ s + α (See note.)	287 μ s

Note The term α is the delay caused when there is a conflict with another interrupt process. In general, this delay may be anywhere between 6 μ s and 150 μ s long.

Pulse Output Startup Time

The startup time is the time it takes between the execution of a pulse output instruction and the actual output of pulses from the output terminals. The startup time depends on the pulse output instruction being used and the selected operation.

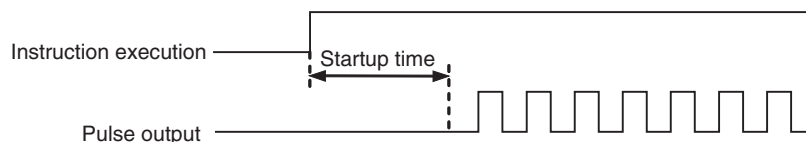

Pulse output instruction	Startup time	
	CJ1M-CPU22/23	CJ1M-CPU21
SPED(885) (Continuous)	46 μ s	63 μ s
SPED(885) (Independent)	50 μ s	68 μ s
ACC(888) (Continuous)	60 μ s	85 μ s
ACC(888) (Independent, trapezoidal control)	66 μ s	95 μ s
ACC(888) (Independent, triangular control)	68 μ s	98 μ s
PLS2(887) (Trapezoidal control)	70 μ s	100 μ s
PLS2(887) (Triangular control)	72 μ s	104 μ s

Pulse Output Change Response Time

In some cases, another pulse output instruction can be executed during a pulse output operation to change the settings or the operation itself. The change response time is the time it takes between the execution of another pulse output instruction and the actual change in the pulse output at the output terminals.

Pulse output instruction	Change response time	
	CJ1M-CPU22/23	CJ1M-CPU21
INI(880) (Immediate stop)	60 μ s + 1 pulse output time	67 μ s + 1 pulse output time
SPED(885) (Immediate stop)	62 μ s + 1 pulse output time	80 μ s + 1 pulse output time
ACC(888) (Decelerate to a stop)	Between 1 control cycle (4 ms) and 2 control cycles (8 ms)	
PLS2(887) (Decelerate to a stop)	Between 1 control cycle (4 ms) and 2 control cycles (8 ms)	
SPED(885) (Change speed)	Between 1 control cycle (4 ms) and 2 control cycles (8 ms)	
ACC(888) (Change speed)	Between 1 control cycle (4 ms) and 2 control cycles (8 ms)	
PLS2(887) (Change target position, reverse)	Between 1 control cycle (4 ms) and 2 control cycles (8 ms)	
PLS2(887) (Change target position, same direction, same speed)	Between 1 control cycle (4 ms) and 2 control cycles (8 ms)	
PLS2(887) (Change target position, same direction, change speed)	Between 1 control cycle (4 ms) and 2 control cycles (8 ms)	

Index

A

- absolute coordinates
 - selecting, 159
- absolute pulse outputs, 159
- acceleration rate
 - changing, 3
 - setting, 5
- allocations
 - Auxiliary Area data allocation, 68
 - built-in CPU Unit inputs, 12
 - built-in CPU Unit outputs, 15
 - connector pin allocations, 23
 - data area allocation, 51
 - origin search function, 16
- applications
 - precautions, xxxi
- Auxiliary Area data allocation, 68

B

- bit allocations
 - general-purpose inputs, 126
 - general-purpose outputs, 145
 - high-speed counter inputs, 132
 - interrupt inputs (counter mode), 129
 - interrupt inputs (direct mode), 128
 - origin search function, 170
 - pulse outputs, 146
 - PWM(891) outputs, 167
- built-in CPU Unit inputs
 - allocations, 12
- built-in CPU Unit outputs
 - allocations, 15
- built-in I/O
 - data area allocation, 52
- built-in I/O functions, 4
 - details, 125
 - overview, 11
- built-in inputs
 - details, 126
 - PLC Setup settings, 52
- built-in outputs
 - Auxiliary Area data allocations, 72
 - details, 144
 - programming examples, 192

C

- CJ Series
 - definition, xix
- CJ1W-NC
 - comparison of pulse output functions, 10
- comparing tables, 93
- comparison, 93
 - resetting counters, 6
- connector pin allocations, 23
- connectors
 - flat cable connectors, 29
 - loose wire crimp connectors, 29
 - models, 29
- continuous mode (speed control), 149
- controlling pulse outputs, 8
- coordinate systems (absolute or relative), 160
- Count Direction Flag, 5
- counting modes
 - details, 137
- CPM2C
 - compatibility, 225
- CPU Unit Ver. 2.0, 5
- CQM1H
 - compatibility, 225
- CS Series
 - definition, xix
- Customizable Counter Units
 - compatibility, 225
- CW/CCW limit inputs
 - applications, 5
 - pulse output functions, 164
- CW/CCW pulse outputs, 2
 - connection example, 38

D

- deceleration rate
 - setting, 5
- delaying pulse output
 - programming example, 195
- differential phase mode
 - details, 135
- direction
 - automatic direction selection, 2, 162
- duty factor
 - pulse with variable duty factor, 122
- duty ratio, 5

E

- EC Directives, xxxiv
- encoders
 - connecting 24-V DC open-collector outputs, 35
 - connecting line driver outputs, 36
- error codes
 - pulse output stop error codes, 185
- Error Counter Reset Output
 - connection example, 40
- error processing
 - origin search, 185

F

- features, 1
- fixed distance feed interrupt, 3
- fixed duty ratio pulse outputs
 - allocations, 15
- fixed feeding
 - programming example, 201
- flags
 - flag operations during pulse output, 76
- frequency
 - frequency measurement, 141
 - input pulse frequency, 2, 5

G

- Gate Bit
 - high-speed counters, 141
- general-purpose inputs
 - allocations, 12
 - connector pin usage, 24
 - details, 126
 - input time constant settings, 57
 - restrictions, 127
 - specifications, 20
- general-purpose outputs
 - allocations, 15
 - connector pin usage, 26
 - details, 145
 - restrictions, 145

H

- hardware interrupt response time, 229
- high-speed counter and pulse output instructions, 79
- high-speed counter function, 2

- Count Direction Flag, 5
- High-speed Counter Gate Bit, 141
- high-speed counter inputs
 - details, 131
 - reset methods, 138
 - restrictions, 134
- high-speed counters
 - allocations, 12
 - Auxiliary Area data allocation, 68
 - connector pin usage, 25
 - PLC Setup settings, 52
- high-speed counting
 - reading the PV, 83
- high-speed processing functions, 6

I

- I/O specifications, 19
- immediate refreshing, 2
- increment mode
 - details, 136
- independent mode (positioning), 152
- input operation settings
 - IN0 to IN3, 56
- input time constant, 2
 - settings, 57
- inrush current considerations, 34
- installation
 - precautions, xxxi
- instructions
 - ACC(888), 111
 - controlling high-speed counters and pulse outputs, 79
 - CTBL(882), 93
 - high-speed counter instructions, 79
 - INI(880), 80
 - ORG(889), 118
 - PLS2(887), 104
 - PRV(881), 83
 - PRV2(883), 9, 14
 - PULS(886), 102
 - pulse output instructions, 79
 - PWM(891), 122
 - SPED(885), 98
- interrupt feeding, 217
 - ladder program, 219
- interrupt inputs, 2
 - allocations, 12
 - Auxiliary Area data allocations, 68
 - connector pin usage, 24

- counter mode, 129
- details, 128
- direct mode, 128
- restrictions, 129, 130

interrupt response times, 229

J

jog operation

- programming example, 199

L

length measurement program, 192

Limit Input Signal Type, 184

limit inputs

- CW/CCW, 164

linear mode counting

- details, 137

M

motor driver

- connection examples, 40

multiple progressive positioning, 204

- ladder program, 208
- wiring example, 206

multiple start function, 3

O

OMNUC W-series, UP-series, or UT-series Servo Driver

- connections, 31, 32

operating environment

- precautions, xxx

operating mode 0

- connection example, 41

operating mode 1

- connection example, 42

operating mode 2

- connection example, 45

Origin Compensation, 183

Origin Detection Method, 179

Origin Input Signal

- connection example, 37

Origin Input Signal Type, 184

Origin Proximity Input Signal Type, 184

origin return function, 3

- details, 169
- examples, 189
- PLC Setup settings, 66

Origin Return Parameters, 190

origin search, 3

- error processing, 185
- examples, 187
- executing, 184

Origin Search Acceleration Rate, 183

Origin Search Deceleration Rate, 183

Origin Search Direction

- specifying, 183

origin search function

- allocations, 16
- details, 169
- I/O usage, 28
- PLC Setup settings, 57, 173
- restrictions, 172

Origin Search High Speed, 183

Origin Search Operation Setting, 179

Origin Search Parameters, 176

Origin Search Proximity Speed, 183

Origin Search/Return Initial Speed, 183

origin status

- operations affecting, 161

Output, 166

output short protection, 34

output wiring precautions, 34

P

palletize, 209

PCBs

- multiple progressive positioning, 204

PLC Setup settings, 51, 52

PLCs

- compatibility table, 225

positioning, 152

- programming example, 197
- programming examples, 204, 209, 217
- vertically conveying PCBs, 204

Positioning Monitor Time, 184

power supply input

- connection example, 36

precautions, xxvii

- applications, xxxi
- general, xxviii
- general precautions, xxvii

- intended audience, xxviii
- operating environment, xxx
- safety, xxviii
- safety precautions, xxviii
- programming examples, 191
- pulse + direction mode
 - details, 135
- pulse + direction outputs, 2
 - connection example, 38
- pulse control instructions
 - combinations, 221
- pulse frequency conversion, 5, 14, 91, 142
- pulse input modes
 - details, 135
- pulse inputs
 - connection examples, 35
- Pulse Output 0 settings, 58
 - limit input signals, 164
 - speed curve, 166
 - undefine origin, 165
- Pulse Output 1 settings, 62
 - limit input signals, 165
 - speed curve, 166
 - undefine origin, 165
- pulse output change response time, 230
- pulse output instructions, 148
 - compatibility in other PLCs, 225
 - required conditions, 157
- pulse output modes, 149
- pulse output patterns, 149
- pulse output startup time, 230
- pulse output stop error codes, 185
- pulse outputs, 79
 - connection examples, 37
 - connector pin usage, 27
 - controlling, 80, 111
 - details, 145
 - pulse output instructions, 148
 - specifications, 22
 - with trapezoidal acceleration/deceleration, 164
- PWM(891) outputs
 - bit allocations, 167
 - connection example, 49
 - connector pin usage, 27
 - details, 167
 - restrictions, 168
 - specifications, 23

Q

- quick-response inputs, 3
 - allocations, 12
 - connector pin usage, 24
 - details, 143
 - restrictions, 143

R

- range comparison, 96
- receiving pulse inputs, 9
- refreshing
 - immediate refreshing, 2
 - refreshing high-speed counter PVs, 2
- relative coordinates
 - selecting, 159
- relative pulse outputs, 159
- reset methods, 138
- response time, 229
- ring mode counting
 - details, 137

S

- safety precautions, xxviii
- S-curve acceleration/deceleration, 5, 165
 - output pattern, 166
 - restrictions, 167
- Servo Driver
 - connections, 30
- SMARTSTEP A-series or UE-series Servo Driver
 - connections, 30, 31
- SMARTSTEP A-series Servo Driver
 - connection example, 44
- software interrupt response time, 229
- software reset, 138
- specifications
 - general-purpose input specifications, 20
 - hardware specifications, 144
 - high-speed counter input specifications, 21
 - high-speed counter inputs, 134
 - I/O specifications, 19
 - input characteristics, 144
 - input specifications, 20
 - interrupt input (counter mode), 131
 - interrupt input (direct mode), 129
 - interrupt input specifications, 20
 - output specifications, 22

- pulse outputs, 147
- PWM(891) output, 168
- quick-response input specifications, 20
- quick-response inputs, 144
- transistor
 - outputs (sinking), 22
- speed control, 149
- speed outputs, 98
- stocker, 204

T

- target position
 - changing, 3
- target speed
 - changing, 3
- target value comparison
 - for interrupt tasks, 139
- terminal blocks
 - compatible models, 30
- transistor outputs (sinking)
 - specifications, 22
- trapezoidal control
 - acceleration/deceleration, 164
 - programming example, 197
- triangular control, 3
- TTL connections, 34
- two-axis multipoint positioning, 209
 - ladder program, 214
 - wiring example, 210
- two-wire DC Sensors
 - connection precautions, 33

U

- up/down mode
 - details, 136
- upgrades
 - Ver. 2.0, 5
- U-series (UE) or SMART STEP A-series Servo Driver
 - connection example, 47

V

- variable duty ratio pulse outputs
 - allocations, 15
 - connection example, 49
 - details, 167

- variable duty ratio pulses, 3
- vertical conveyor, 204

W

- wiring, 23
 - connector pin allocations, 23
 - examples, 32
 - DC input devices, 32
 - instructions, 19
 - methods, 28
- W-series or U-series (UP or UT) Servo Driver
 - connection example, 46
- W-series Servo Driver
 - connection example, 43

Revision History

A manual revision code appears as a suffix to the catalog number on the front cover of the manual.

Cat. No. W395-E1-07

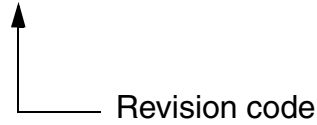

The following table outlines the changes made to the manual during each revision. Page numbers refer to the previous version.

Revision code	Date	Revised content
01	July 2002	Original production
02	December 2003	Revisions and additions to add CPU Unit Ver. 2.0, CJM1-CPU21, and CX-Programmer Ver. 3.2. Pages xi to xx: PLP information updated.
03	August 2004	Unit version information added at beginning of manual. Pages xv and xvi: CPU Unit models added and reference manuals added. Page 5: Heading 1-2 changed and section added. Page 82: Information on unit version 3.0 add at top of page and information on operand C added. Page 83: Information on unit version 3.0 add in table. Page 86: Heading for C = 0003 hex replaced and information added. Page 87: Description of C replaced. Pages 87 to 89: Operand abbreviations changed. Page 223: Information added in first cell for PRV under CJ1M.
04	August 2005	Page v: Information on general precautions notation added. Page xxi: Information on liability and warranty added.
05	April 2006	Page xviii: Table modified. Page xxx: One precaution modified and one precaution added toward bottom of page. Page xxxi: One precaution modified and two precautions added in middle of page. Page xxxii: Precaution added at top of page. Page 21: Rise time and fall time corrected at top left of table. Page 84: Table modified at top of page. Page 118: Section reference removed at bottom of page. Page 136: Setting procedure added toward bottom of page. Page 205: Data corrected for number of output pulses toward bottom of page.
06	November 2006	Page vi: Modified information on the notation of unit versions on products. Pages x to xiv: Updated information on unit versions. Page xvii: Updated the reference manual table. Page xxx: Modified the graphic on battery disposal. Pages 73 and 75: Added conditions for addresses A28007 and A28107 in the last column (times when data is accessed).
07	February 2008	Added “or later” after “CPU Unit Ver. 2.0” (sometimes replacing “only”) throughout the manual. Page 29: Added notes and changed “Connector” to “Spare Contacts” in top table. Pages 89, 92, and 130: Added note. Page 105: Changed label of bits 00 to 03 in M.

Revision History
