

3G3MV-P10CDT□-E

# V7 inverter PLC

The OMRON PLC technology embedded in the most popular inverter: the V7

- OMRON PLC programmability for the 3G3MV inverter
- Stand-alone applications.
- Flexibility and intelligence into the 3G3MV.
- Wireless installation and seamless access to the inverter parameters and analogue/digital inputs and outputs.
- Standard OMRON tools can be used for programming and commissioning.
- Ideal for applications like: door control, pump sequencing, Intelligent conveyor, Vertical axis control, Industrial washing machines and general positioning.



## System configuration

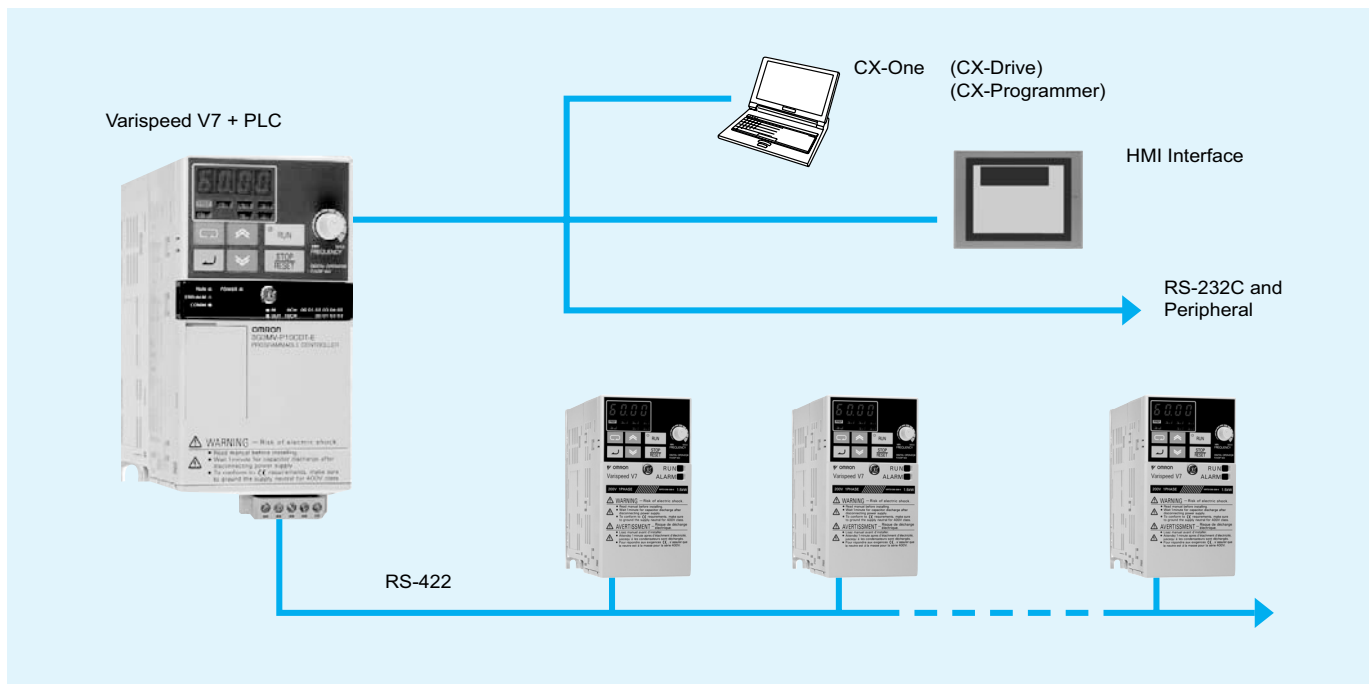

Type designation

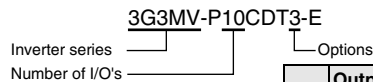

	Output	RTC	RS422	Remarks
-	NPN	NO	NO	Standard
1	NPN	NO	YES	
2	NPN	YES	NO	
3	NPN	YES	YES	Standard
5	PNP	NO	NO	Standard
6	PNP	NO	YES	
7	PNP	YES	NO	
8	PNP	YES	YES	

Specifications

Specifications by product

Item	3G3MV-P10CDT-E	3G3MV-P10CDT5-E	3G3MV-P10CDT3-E
PLC core	CPM2C-S	CPM2C-S	CPM2C-S
Inputs	6 24 VDC inputs	6 24 VDC inputs	6 24 VDC inputs
Outputs	3 sinking/NPN transistor outputs	3 sinking/PNP transistor outputs	3 sinking/NPN transistor outputs
	1 relay output	1 relay output	1 relay output
Peripheral port	Yes	Yes	Yes
RS-232C port	Yes	Yes	Yes
RS-422/485 port	No	No	Yes
Calendar/clock	No	No	Yes
Memory backup	Flash memory and capacitor	Flash memory and capacitor	Flash memory and battery

General specifications

Item	Specifications
Rated power supply voltage	24 VDC $+10\%$ / $-15\%$ (external power supply for I/O)
Vibration resistance	0.15 mm (10-57 Hz) 9.8 m/s <sup>2</sup> (57-150 Hz) 9.8 m/s <sup>2</sup> (57-150 Hz) In all directions (X, Y, Z)
Ambient operating temperature	-10 to 45 °C
Ambient operating relative humidity	10% to 90% (no condensation)
Ambient storage temperature	-20 to 70 °C
Atmosphere	Must be free from corrosive gas
Power consumption	2 W (supplied internally)
Control method	Store program method
I/O control method	Cyclic scan method
Programming language	Ladder chart method
Instruction length	1 step/1 instruction; 1 to 5 words/1 instruction
Instruction types	Basic 14 types (same as for programmable slaves.) Special 105 types, 185 instructions (same as for programmable slaves.)
Processing speed	Basic instructions 0.64 μs (LD) Special instructions 7.8 μs (MOV)
Program capacity	4,096 words
Maximum number of I/O points	10
Input bits	00000 to 00015 (6 physical inputs)
Output bits	01000 to 01003 (4 physical outputs)
Area allocated to inverter	320 bits: 20000 to 21915
Inverter interface	Direct interface with V7 inverter through • IR-memory • DM-memory • Transfer command
IR area	880 bits: IR 00100 to IR 00915 (words IR 001 to IR 009), IR 01100 to IR 02815 (words IR 011 to IR 028), IR 03000 to IR 04915 (words IR 030 to IR 049), IR 22000 to IR 22715 (words IR 220 to IR 227)
SR area	448 bits: SR 22800 to SR 25507 (words SR 228 to SR 255)
TR area	8 bits (TR 0 to TR 7)
HR area	320 bits: HR 0000 to HR 1915 (words HR 00 to 19)
AR area	384 bits: AR 0000 AR 2315 (words AR 00 to AR 23)
LR area	256 bits: LR 0000 to LR 1515 (words LR 00 to LR 15)
Timer/counter area	256 bits: TC 000 to TC 255
DM area	Read/write 2029 words (DM 0000 to DM 0999, DM 1019 to DM 2047) DM 2000 to DM 2021: error log storage area Read only 456 words (DM6144 to 6599) Allocated to inverter 19 words (DM 2022 to DM 2040) PLC setup 56 words (DM 6599 to DM 6655)
Quick-response input	2 inputs (minimum input signal width: 50 μs)

Item		Specifications
Interrupt processing	External interrupts	2 bits (used in common for input interrupt counter mode and high-speed inputs.)
	Scheduled interrupts	1 bit (scheduled interrupts or one-shot interrupts)
Interrupts	Interrupt inputs 2 inputs	Response time: 50 µs
	Interval timer interrupts 1 input	Set value: 0.5 to 319,968 ms Precision: 0.1 ms
		Scheduled interrupts One-shot interrupt
High-speed counters	High-speed counter 1 input, see note 5	No interrupt
	<ul style="list-style-type: none"> <li>Differential phase mode (5 kHz)</li> <li>Pulse plus direction input mode (20 kHz)</li> <li>Up/down input mode (20 kHz)</li> <li>Increment mode (20 kHz)</li> </ul>	Count-check interrupt (an interrupt can be generated when the count equals the set value or the count lies within a preset range.)
	Interrupt inputs (counter mode) 2 inputs	No interrupt
Pulse outputs	<ul style="list-style-type: none"> <li>2 outputs: Single-phase pulse output without acceleration/deceleration (see note 6.) 10 Hz to 10 kHz</li> <li>2 outputs: Variable duty ratio pulse output (see note 6.) 0.1 to 999.9 Hz, duty ratio 0 to 100%</li> <li>1 output: Pulse output with trapezoidal acceleration/deceleration (see note 6.) Pulse plus direction output, up/down pulse output, 10 Hz to 10 kHz</li> </ul>	Count-up interrupt
	Synchronized pulse control	1 point, see notes 5 and 6 Input frequency range: 10 to 500 Hz, 20 Hz to 1 kHz, or 300 Hz to 20 kHz Output frequency range: 10 Hz to 10 kHz
Analog volume	None	
Input time constant (ON response time = OFF response time)	Determines the input time constant for all inputs. (Settings: 1, 2, 3, 5, 10, 20, 40, or 80 ms)	
Clock/calendar function	Yes. Shows the current year, month, day of the week, day of the month, hour, minute, and second.	
Communication function	Port 1 = Peripheral and RS-422 host link, peripheral bus, no-protocol, programming console Port 2 = RS-232C port: host link, no-protocol, 1:1 PLC link, 1:1 NT link	
Power-interruption hold function	Holds the contents of HR, AR, CNT, and DM areas.	
Memory backup	Non-volatile memory, user program, DM (read only), PLC setup Fixed internal lithium battery (5 years, not replaceable by the user) or capacitor DM (read/write), HR, SR and CNT areas	
Self-diagnostic function	CPU errors, memory errors, communications errors, setting errors, battery errors	
Program check	No END instruction, program errors (regularly checked during operation)	
Connected tools	CX-programmer	After version 2.1
	Programming console	C200H-PRO27, CQM1-PRO01
	SSS	PC98 & PC/AT (SYSMAC support software, all version)
	CX-drive	-

- Note:**
- The DM area, HR area, AR area, and counter values are backed up. If the backup battery or capacitor is discharged, the contents of these areas will be lost and the data values will revert to the defaults.
  - The contents of the program area, read-only DM area (DM6144 to DM6599), and PLC setup (DM 6600 to DM 6655) are stored in flash memory. The contents of these areas will be read from flash memory the next time the power is turned ON, even if the backup battery or capacitor is discharged. When data has been changed in any of these areas, write the new values to flash memory by switching the 3G3MV-P10CDT to MONITOR or RUN mode, or by turning the power OFF and then ON again.
  - Changes made while in MONITOR mode using, for example, online editing, are written to flash memory in real-time.
  - The above figure for power consumption includes the power consumption of the programming console.
  - This input is shared by the high-speed counter and synchronized pulse control functions.
  - This output is shared by the pulse output and synchronized pulse control functions

## I/O specifications

### Input specifications

Item	Inputs	Specification
Input voltage	All	24 VDC <sup>+10%</sup> / <sub>-15%</sub>
Input impedance	IN00000 to IN00001	2.7 kΩ
	IN00002 to IN00004	3.9 kΩ
	IN00005	4.7 kΩ
Input current	IN00000 to IN00001	8 mA typical
	IN00002 to IN00004	6 mA typical
	IN00005	5 mA typical
ON voltage/current	IN00000 to IN00001	17 VDC min., 5 mA
	IN00002 to IN00005	14.4 VDC min., 3.5 mA
OFF voltage/current	All	5.0 VDC max., 1.1 mA
ON delay	All	1 to 80 ms max. Default: 10 ms (see note)

Item	Inputs	Specification
OFF delay	All	1 to 80 ms max. default: 10 ms (see note.)
Circuit configuration	IN00000 to IN00001	
	IN00002 to IN00004	
	IN00005	

**Note:** The input time constant can be set to 1, 2, 3, 5, 10, 20, 40, or 80 ms in the PLC setup.

### High speed counter inputs

The following unit input bits can be used as high-speed counter inputs. The maximum count frequency is 5 kHz in differential phase mode and 20 kHz in the other modes.

Input	Function			
	Differential phase mode	Pulse plus direction input mode	Up/down input mode	Increment mode
IN00000	A-phase pulse input	Pulse input	Increment pulse input	Increment pulse input
IN00001	B-phase pulse input	Direction input	Decrement pulse input	Normal input
IN00002	Z-phase pulse input or hardware reset input (IN00002 can be used as a normal input when it is not used as a high-speed counter input.)			

The minimum pulse widths for inputs IN00000 (A-phase input) and IN00001 (B-phase input) are as follows:

Pulse plus direction input mode,  
Up/down input mode, increment mode

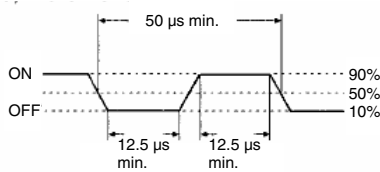

Differential phase mode

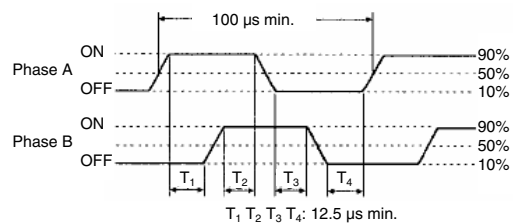

The minimum pulse width for input IN00002 (Z-phase input) is as follows:

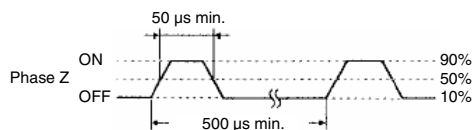

### Interrupt inputs

The 3G3MV-P10CDT is equipped with inputs that can be used as interrupt inputs (interrupt input mode or counter mode) and quick-response inputs. The minimum pulse width for these inputs is 50 μs.

Inputs IN00003 and IN00004 can be used as interrupt inputs.

**Output Specification**

**Relay output**

Item	Specification
Maximum switching capacity	2 A, 250 VAC (cosφ=1) 2A, 24VDC
Minimum switching load	10 mA, 5 VDC
Service life of relay	Electrical: 150,000 operations (24 VDC resistive load) 100,000 operations (240 VAC inductive load cosφ=0.4) Mechanical: 20,000,000 operations
ON delay	15 ms max.
OFF delay	15 ms max.
Circuit configuration	

**Note:** The service life of relay output contacts shown in the table assumes the worst conditions. The following graph shows the results of OMRON's service life tests at a switching rate of 1,800 times/hour.

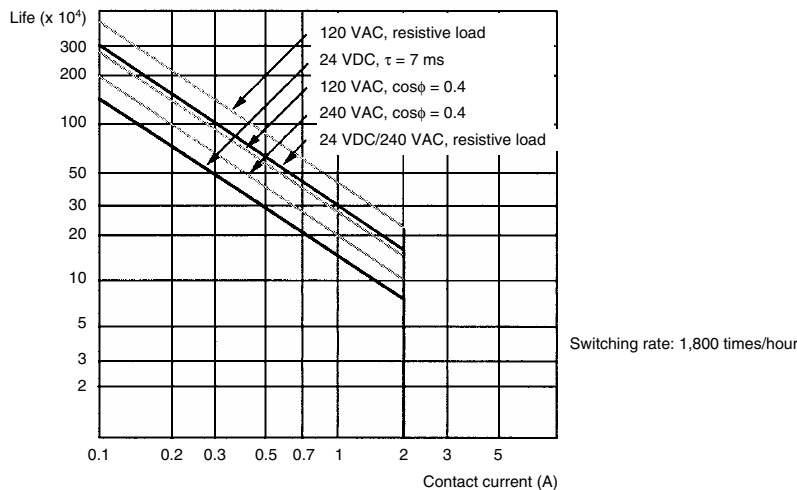

**Transistor outputs (sinking/NPN)**

Item	Specification
Maximum switching capacity	4.5 to 30 VDC, 0.2 A/ output
Minimum switching capacity	0.5 mA
Maximum inrush current	0.9 A for 10 ms
Leakage current	0.1 mA
Residual voltage	1.5 V max.
ON response time	20 μs max.
OFF response time	40 μs max. for 4.5 to 26.4 VDC, 10 to 100 mA 0.1 ms max for 4.5 to 30 VDC, 10 to 200 mA
Fuse	One fuse per output (cannot be replaced by user)
Circuit configuration	

**Note:** When using OUT01000 or OUT01001 as a pulse output, connect a dummy resistor as required to bring the load current between 0.01 and 0.1 A. If the load current is below 0.1 A, the ON-to-OFF response time will be longer and high-speed pulses (source-type transistor outputs) will not be output. If the load current is above 0.1 A, the transistor will generate more heat and components may be damaged.

**Caution**  
Do not apply voltage in excess of the maximum switching capacity to an output terminal. It may result in damage to the product or fire

Operation

CPU unit component descriptions

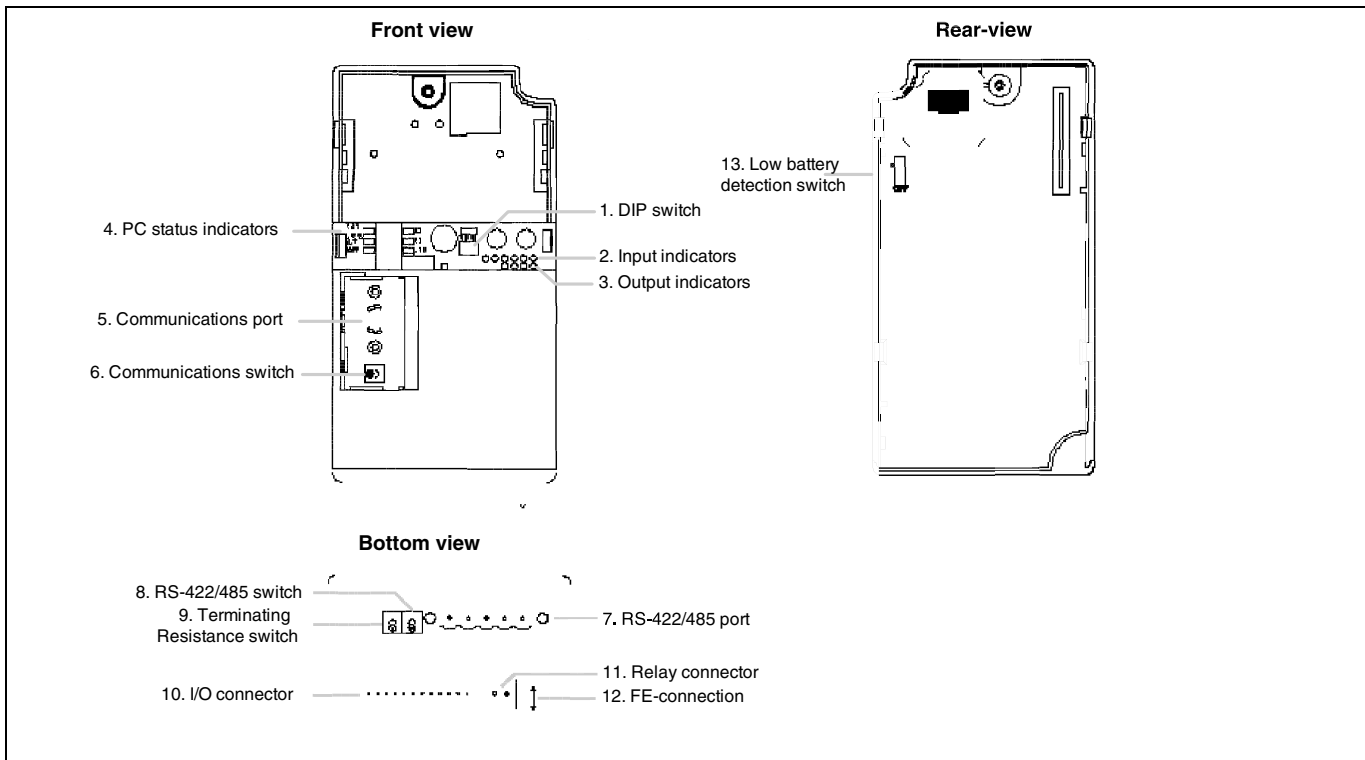

1. DIP switch

- RS-232C and peripheral port settings

	Pin 1	Effective port settings
	OFF (default)	The ports operate according to the settings in the PLC Setup. RS-232C port settings: DM 6645 to DM 6649 Peripheral port settings: DM 6650 to DM 6654
	ON	The ports operate with the standard communications settings.

- Operating mode at startup

Pin 2 determines the operating mode at startup only if there isn't a programming Device connected to the peripheral port.

Programming device connected	Startup mode with pin 2 OFF (default)	Startup mode with pin 2 ON
None	PROGRAM mode	RUN mode
Programming console	Operating mode set on the programming console's mode switch	
Other device	PROGRAM mode	

2. Input indicators (yellow)

The input indicators are lit when the corresponding input terminal is ON. The status of an input indicator will reflect the status of the input even when that input is being used for a high-speed counter.

- Note:**
1. When interrupt inputs are used in interrupt input mode, the indicator may not light even when the interrupt condition is met if the input is not ON long enough.
  2. Input indicators will reflect the status of the corresponding inputs even when the PLC is stopped, but the corresponding input bits will not be refreshed.

3. Output indicators (yellow)

The output indicators are lit when the corresponding output terminal is ON. The indicators are lit during I/O refreshing. The status of an output indicator will also reflect the status of the corresponding output when the output is being used as a pulse output.

4. PLC status indicators

The following indicators show the operating status of the PLC.

Indicator	Status	Meaning
PWR (green)	ON	Power is being supplied to the unit
	OFF	Power isn't being supplied to the unit
RUN (green)	ON	The PLC is operating in RUN or MONITOR mode
	OFF	The PLC is in PROGRAM mode or a fatal error has occurred.
ERR/ALM (red)	ON	A fatal error has occurred. (PLC operation stops.)
	Flashing	A non-fatal error has occurred. (PLC operation continues.)
	OFF	Indicates normal operation.
COMM1 (yellow)	Flashing	Data is being transferred via the peripheral or RS-422/485 port.
	OFF	Data isn't being transferred via communications port.
COMM2 (yellow)	Flashing	Data is being transferred via the RS-232C port
	OFF	Data isn't being transferred via communications port.

5. Communications port

Connects the PLC to a programming device (including programming consoles), host computer, or standard external device. Use a proper connecting cable (CPM2C-CN111, CS1W-CN114, CS1W-CN118, or CS1W-CN226).

- Note:**
1. A CQM1H-PRO01-E programming console can be connected directly to the PLC.
  2. A C200H-PRO27-E programming console can be connected directly to the PLC with a CS1W-CN224/CN624 connecting cable.
  3. Use a CPM2C-CN111 or CS1W-CN114 connecting cable to connect to the communications port as a peripheral port. The communications port can be used simultaneously as both a peripheral port and RS-232C port by using the CPM2C-CN111 connecting cable.
  4. Use a CPM2C-CN111, CS1W-CN118 or CS1W-CN226 connecting cable to connect to the communications port as a RS-232C port. The communications port can be used simultaneously as both a peripheral port and RS-232C port by using the CPM2C-CN111 connecting cable

**Note:** The peripheral port and RS-422/485 port cannot be used simultaneously. When using the peripheral port disconnect any devices connected to the RS-422/485 port.

### 6. Communications switch

Switch to select port 1 type of connected device

Position	Communication Port 1
OFF (default)	Programming console
ON	RS-422/485 communication

### 7. RS-422/485 port (3G3MV-P10CDT3-E only)

Used to connect to host computers, or standard external devices.

Terminal arrangement

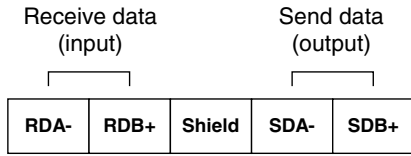

Connector: Phoenix MSTB 2.5/5-STF-5.08AU

**Note:** The maximum line length is 500 m.

**Note:** The peripheral port and RS-422/485 port cannot be used simultaneously. When using the peripheral port disconnect any devices connected to the RS-422/485 port.

### 8. RS-422/485 switch (3G3MV-P10CDT3-E only)

Switch to select 4-wire (RS-422) or 2-wire (RS-485) communication

Position	Status
OFF (down) (default)	4-wire communications
ON (up)	2-wire communications

### 9. Terminating resistance switch (3G3MV-P10CDT3-E only)

Position	Termination
OFF (down) (default)	Disabled
ON (up)	Enabled

Set this switch to ON only for double-ended connection to a host link network.

### 10. I/O connector

Connects the CPU unit to external input and output devices.

Sinking/NPN outputs

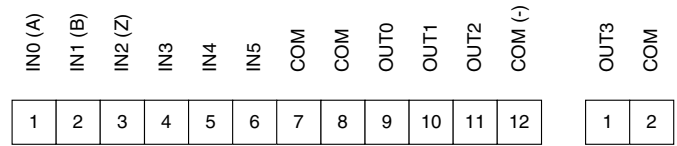

Connector: WAGO 733-112 (wire cross section 0.08 to 0.50 mm<sup>2</sup>)

### 11. Relay connector

Connects the CPU unit to an external output device.

Connector: WAGO 734-102 (wire cross section 0.08 to 1.50 mm<sup>2</sup>)

### 12. FE-connection

AMP tab to connect functional earth. Internally connected to pin 3 of the RS-422/485 connector and to the shell of the peripheral connector.

### 13. Low battery detection switch (3G3MV-P10CDT3-E only)

This switch enables or disables the detection of a low-battery error.

	Position	Low-battery detection
	ON (up) (default)	Error detection enabled
	OFF (down)	Error detection disabled

## Dimensions

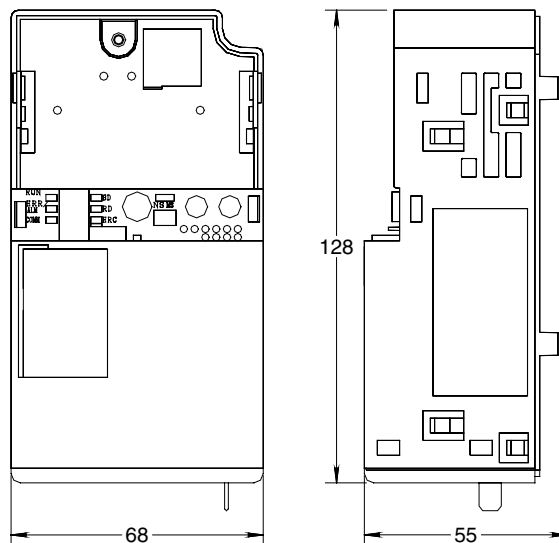

Applications examples

V7 + PLC in positioning application

point-to-point applications are possible adding the PLC to the V7, including the possibility to add position and speed tables or even use recipes that could be select using a HMI

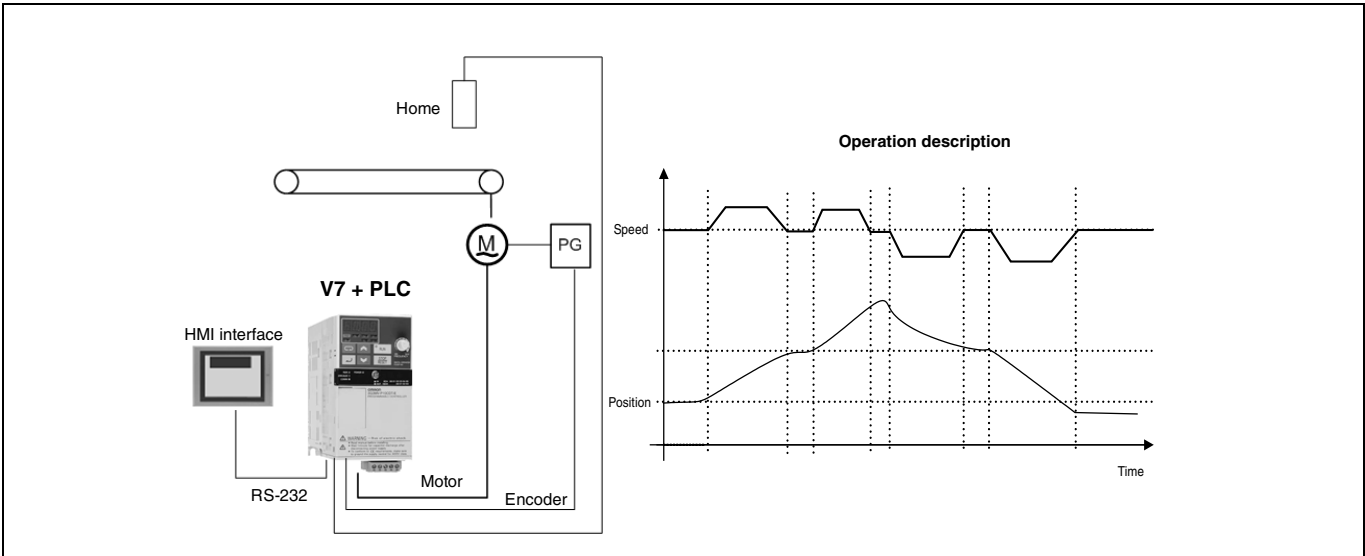

**Note:** For detailed information about the inverter, please refer to Varispeed V7 section.

V7 + PLC with pump

Using the PLC, it is possible to control a modulated plus several auxiliar pumps according your own parameters and system demand. It is also possible to add a GSM modem to advice about any problem.

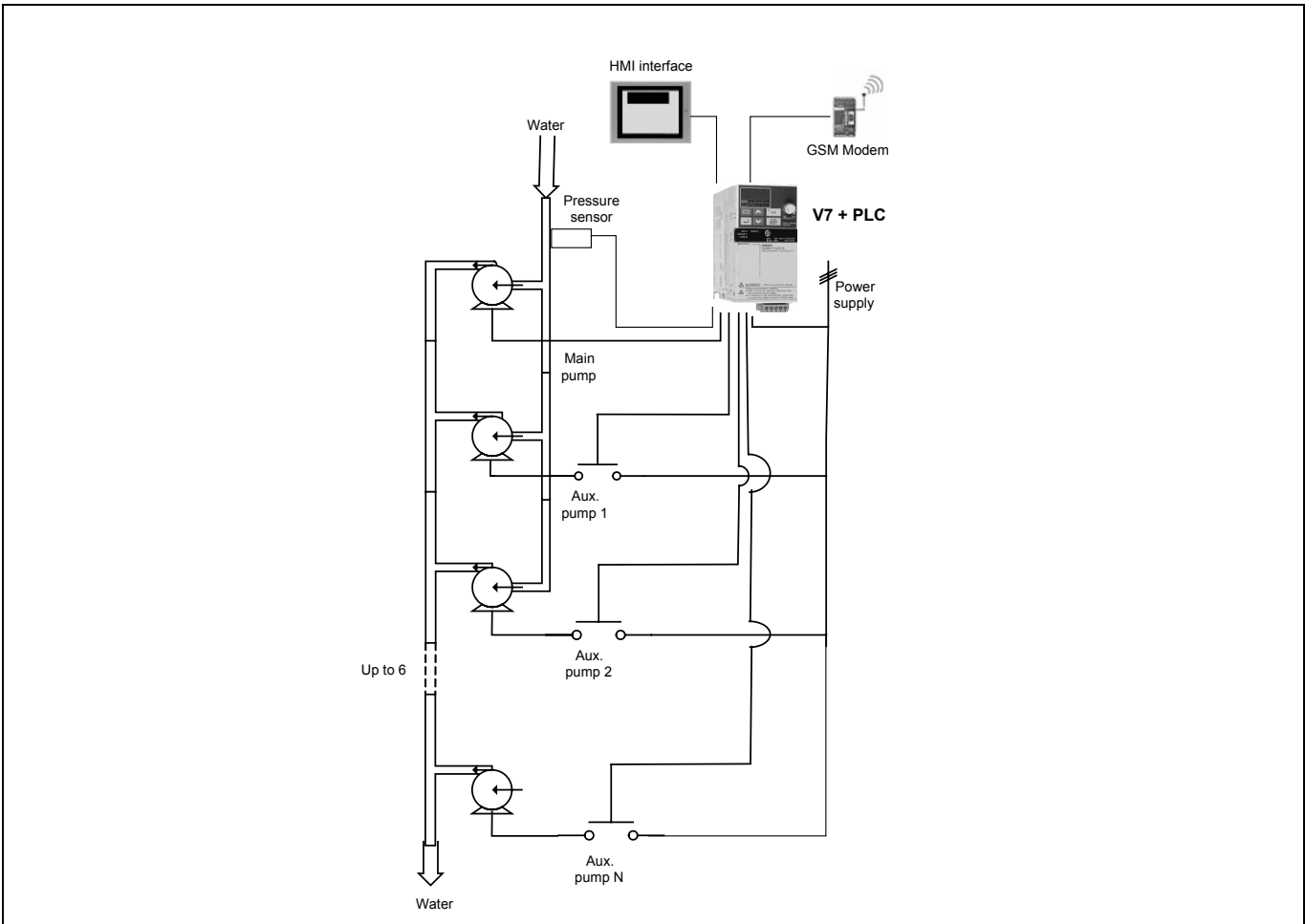

**Note:** For detailed information about the inverter, please see into the Varispeed V7 section.

Ordering information

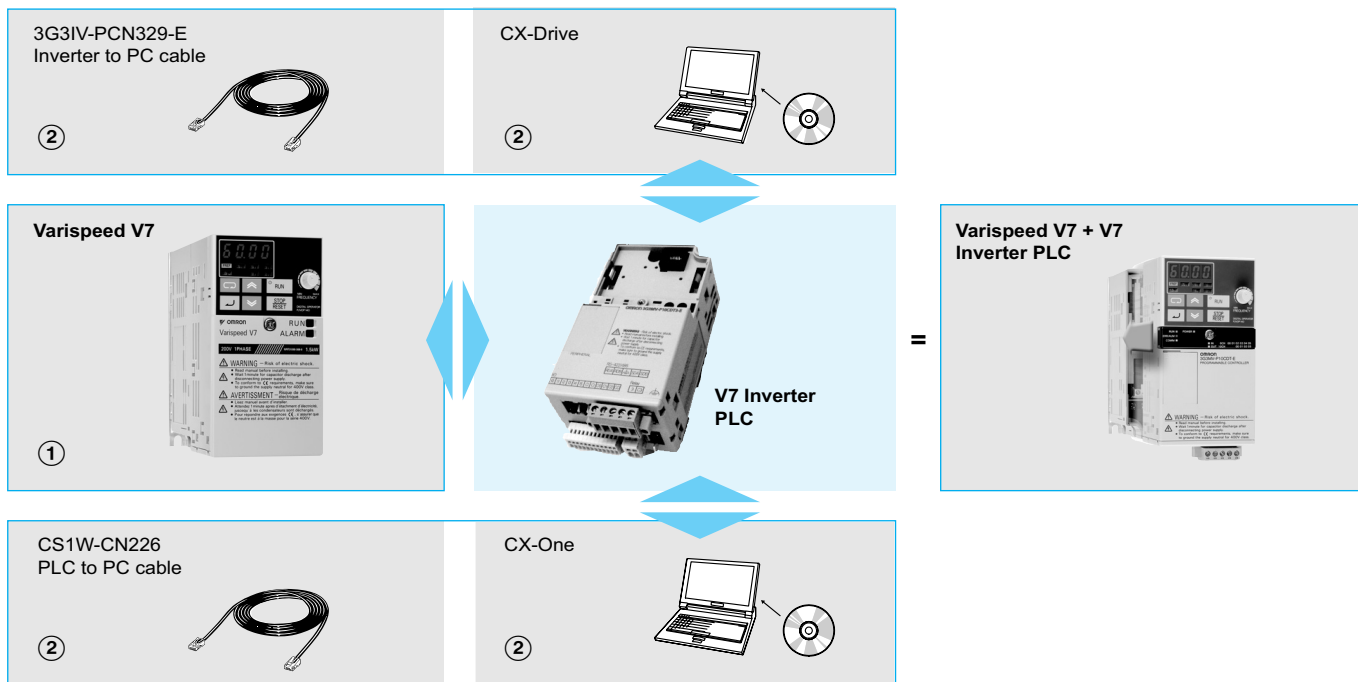

V7 inverter PLC

Specifications				Model
Inputs	Outputs	RS422 port	RTC	
6	4	No	No	3G3MV-P10CDT-E
6	4	Yes	Yes	3G3MV-P10CDT3-E

① Varispeed

Specifications	Model
Sensorless vector control inverter	Varispeed V7

Note: For detailed information, please refer to Varispeed V7 series section.

② Cables

Specifications	Model
Computer connecting cable	CS1W-CN226
Programmable console cable	CS1W-CN224

② Software

Specifications	Model
PLC programming software: CX-programmer	CX-One
Inverter configurator software: CX-drive	

ALL DIMENSIONS SHOWN ARE IN MILLIMETERS.

To convert millimeters into inches, multiply by 0.03937. To convert grams into ounces, multiply by 0.03527.