

Simple, Compact Inverters

JX Series

Easy-to-use Inverters for simple applications

- Compact models with a wide range of capacity from 0.2 kW to 7.5 kW.
- Main circuit adopts upper/lower wiring as with contactor.
- Side-by-side mounting contributes to space saving. *
- PID Control
- Built-in radio noise filter for three phase type.
- Built-in RS-485 Modbus

* Some models have restrictions in the ambient temperature, carrier frequency, and output current.



Performance Specifications

Inverter 3G3JX

3-phase 200-V Class

Item Model name (3G3JX-)		3-phase 200-V class							
		A2002	A2004	A2007	A2015	A2022	A2037	A2055	A2075
Applicable motor capacity ¹	kW	0.2	0.4	0.75	1.5	2.2	3.7	5.5	7.5
	HP	1/4	1/2	1	2	3	5	7.5	10
Rated output capacity (kVA)	200V	0.4	0.9	1.3	2.4	3.4	5.5	8.3	11.0
	240V	0.5	1.0	1.6	2.9	4.1	6.6	9.9	13.3
Rated input voltage		3-phase (3-wire) 200 V -15% to 240 V +10%, 50/60 Hz ± 5%							
Built-in filter		Radio noise filter							
Rated input current (A)		1.8	3.4	5.2	9.3	13.0	20.0	30.0	40.0
Rated output voltage ²		3-phase: 200 to 240 V (according to the input voltage)							
Rated output current (A)		1.4	2.6	4.0	7.1	10.0	15.9	24.0	32.0
Weight (kg)		0.8	0.9	1.1	2.2	2.4	2.4	4.2	4.2
Cooling method		Self-cooling			Forced-air-cooling				
Braking torque	At short-time deceleration ³ At capacitor feedback	Approx. 50%			Approx. 20% to 40%			Approx. 20%	
	DC injection braking	Injection braking frequency/time, braking force variable, frequency control available							

3-phase 400-V Class

Item Model name (3G3JX-)		3-phase 400-V class						
		A4004	A4007	A4015	A4022	A4037	A4055	A4075
Applicable motor capacity ¹	kW	0.4	0.75	1.5	2.2	3.7	5.5	7.5
	HP	1/2	1	2	3	5	7.5	10
Rated output capacity (kVA)	380V	0.9	1.6	2.5	3.6	5.6	8.5	10.5
	480V	1.2	2.0	3.1	4.5	7.1	10.8	13.3
Rated input voltage		3-phase (3-wire) 380 V -15% to 480 V +10%, 50/60 Hz ± 5%						
Built-in filter		Radio noise filter						
Rated input current (A)		2.0	3.3	5.0	7.0	11.0	16.5	20.0
Rated output voltage ²		3-phase: 380 to 480 V (according to the input voltage)						
Rated output current (A)		1.5	2.5	3.8	5.5	8.6	13.0	16.0
Weight (kg)		1.5	2.3	2.4	2.4	2.4	4.2	4.2
Cooling method		Self-cooling		Forced-air-cooling				
Braking torque	At short-time deceleration ³ At capacitor feedback	Approx. 50%			Approx. 20% to 40%			Approx. 20%
	DC injection braking	Injection braking frequency/time, braking force variable, frequency control available						

*1 The applicable motor is a 3-phase standard motor. For using any other type, be sure that the rated current does not exceed that of the Inverter.

*2 Output voltage decreases according to the level of the power supply voltage.

*3 The braking torque at the time of capacitor feedback is an average deceleration torque at the shortest deceleration (when it stops from 50 Hz), not a continuous regeneration torque. Also, the average deceleration torque varies depending on the motor loss. The value is reduced in operation over 50 Hz. Note that no regenerative braking circuit is built into the Inverter. If you need a larger regenerative torque, use the optionally available regenerative braking unit and resistor.

The regenerative braking unit should be used only for short-time regeneration.



Simple, Compact Inverters JX-Series

1/3-phase 200-V Class

Item Model name (3G3JX-)		1/3-phase 200-V Class				
		AE002	AE004	AE007	AE015	AE022
Applicable motor capacity ^{*1}	kW	0.2	0.4	0.75	1.5	2.2
	HP	1/4	1/2	1	2	3
Rated output capacity (kVA)	200V	0.4	0.9	1.3	2.4	3.4
	240V	0.5	1.0	1.6	2.9	4.1
Rated input voltage		1/3-phase 200 V -15% to 240 V +10%, 50/60 Hz ± 5%				
Built-in filter		None				
Rated input current (A)	1-phase	3.1	5.8	9.0	16.0	22.5
	3-phase	1.8	3.4	5.2	9.3	13.0
Rated output voltage ^{*2}		3-phase: 200 to 240 V (according to the input voltage)				
Rated output current (A)		1.4	2.6	4.0	7.1	10.0
Weight (kg)		0.8	0.9	1.1	2.2	2.4
Cooling method		Self-cooling			Forced-air-cooling	
Braking torque	At short-time deceleration ^{*3}	Approx. 50%			Approx. 20% to 40%	
	At capacitor feedback					
	DC injection braking	Injection braking frequency/time, braking force variable, frequency control available				

*1 The applicable motor is a 3-phase standard motor. For using any other type, be sure that the rated current does not exceed that of the Inverter.

*2 Output voltage decreases according to the level of the power supply voltage.

*3 The braking torque at the time of capacitor feedback is an average deceleration torque at the shortest deceleration (when it stops from 50 Hz), not a continuous regeneration torque. Also, the average deceleration torque varies depending on the motor loss. The value is reduced in operation over 50 Hz. Note that no regenerative braking circuit is built into the Inverter. If you need a larger regenerative torque, use the optionally available regenerative braking unit and resistor.

The regenerative braking unit should be used only for short-time regeneration.

Function Specifications

Inverter 3G3JX

Item		Specifications
Enclosure rating ^{*1}		Semi-closed (IP20)
Control	Control method	Phase-to-phase sinusoidal modulation PWM
	Output frequency range ^{*2}	0.5 to 400 Hz
	Frequency precision ^{*3}	Digital command: ±0.01% of the max. frequency Analog command: ±0.4% of the max. frequency (25°C ±10°C)
	Frequency setting resolution	Digital setting: 0.1 Hz Analog setting: Max. frequency/1000
	Voltage/Frequency characteristics	V/f characteristics (constant/reduced torque)
	Overload current rating	150% for 1 min
	Acceleration/Deceleration time	0.01 to 3000 s (line/curve selection), 2nd acceleration/deceleration setting available
	Carrier frequency modification range	2 to 12 kHz
	DC injection braking	Starts at a frequency lower than that in deceleration via the STOP command, at a value set lower than that during operation, or via an external input. (Level and time settable.)
Protective functions		Overcurrent, overvoltage, undervoltage, electronic thermal, temperature error, ground-fault overcurrent at power-on state, overload limit, incoming overvoltage, external trip, memory error, CPU error, USP trip, communication error, overvoltage protection during deceleration, momentary power interruption protection, emergency shutdown
Input signal	Multi-function input	FW (forward), RV (reverse), CF1 to CF4 (multi-step speed), JG (jogging), DB (external DC injection braking), SET (2nd function), 2CH (2-step acceleration/deceleration), FRS (free run), EXT (external trip), USP (USP function), SFT (soft lock), AT (analog current input function selection), RS (reset), PTC (thermistor input), STA (3-wire startup), STP (3-wire stop), F/R (3-wire forward/reverse), PID (PID selection), PIDC (PID integral reset), UP (UP of UP/DWN function), DWN (DWN of UP/DWN function), UDC (data clear of UP/DWN function), OPE (forced OPE mode), ADD (frequency addition), F-TM (forced terminal block), RDY (operation ready), SP-SET (special setting), EMR (emergency shutdown)
Output signal	Multi-function output	RUN (signal during operation), FA1 (frequency arrival signal 1), FA2 (frequency arrival signal 2), OL (overload warning signal), OD (PID excess deviation signal), AL (alarm signal), DC (analog input disconnection detection signal), FBV (PID FB status output), NDc (network error), LOG (logical operation result), LOC (light load signal)
	Frequency monitor	Analog output (0 to 10 V DC, 1 mA max.) Frequency/Current signals are selectable via the AM output terminal.
	Relay output	The relay (SPDT contact) outputs signals corresponding to the multi-function output.
Other functions		AVR function, V/f characteristic selection, upper/lower limit, 16-step speeds, starting frequency adjustment, jogging operation, carrier frequency adjustment, PID control, frequency jump, analog gain/bias adjustment, S-shape acceleration/deceleration, electronic thermal characteristics/level adjustment, retry function, simplified torque boost, trip monitor, soft lock function, frequency conversion display, USP function, 2nd control function, motor rotation speed UP/DOWN, overcurrent suppression function
General specifications	Ambient temperature	-10°C to 50°C (Both the carrier frequency and output current need to be reduced at over 40°C.)
	Ambient storage temperature	-20°C to 65°C (short-time temperature during transport)
	Humidity	20% to 90% RH
	Vibration	5.9 m/s ² (0.6G), 10 to 55 Hz (Complies with the test method specified in JIS C0040 (1999).)
	Location	At a maximum altitude of 1,000 m; indoors (without corrosive gases or dust)
Applicable standard		Complies with UL, cUL, CE standards. (Insulation distance)
Options		Noise filter, AC/DC reactors, regenerative braking unit and resistor, etc.

*1 Protection method complies with JEM 1030.

*2 To operate the motor at over 50/60 Hz, contact the motor manufacturer to find out the maximum allowable speed of revolution.

*3 For the stable control of the motor, the output frequency may exceed the maximum frequency set in A004 (A204) by 2 Hz max.

Components and Functions

Inverter 3G3JX

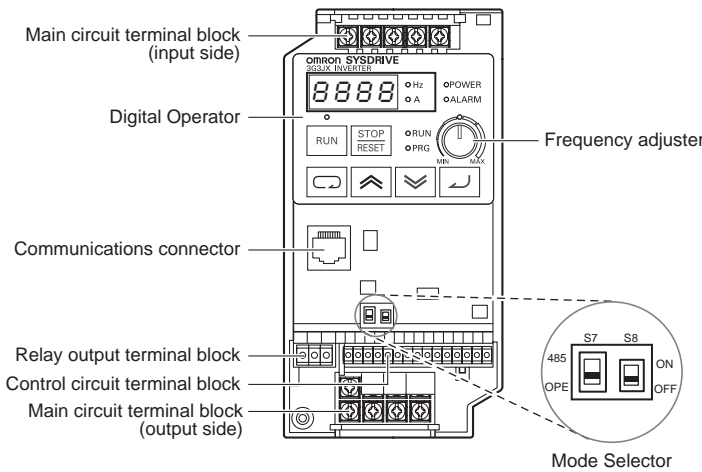

Name	Function
Main circuit terminal block (input side)	Use this terminal block to connect the inverter to the main power supply.
Digital Operator	Used to set parameters, perform various monitoring, and start and stop the Inverter.
Frequency adjuster	Sets the frequency reference within a range between 0 Hz and the maximum frequency.
Communications connector	Use this connector to connect the Digital Operator or to connect the cable for RS-485 communication.
Relay output terminal block	Use this SPDT contact terminal block for relay outputs.
Control circuit terminal block	These terminal blocks are used to connect various digital/analog input and output signals for inverter control, etc.
Main circuit terminal block (output side)	Use this terminal block to connect an output to the motor.
Mode Selector	RS-485 Communication/Operator Selector (S7): Select the mode according to the option connected to the communications connector. Emergency shutoff selector (S8): Use this selector to enable the emergency shutoff input function.

Note: This illustration shows the terminal block with the front cover removed.

Connection Diagram

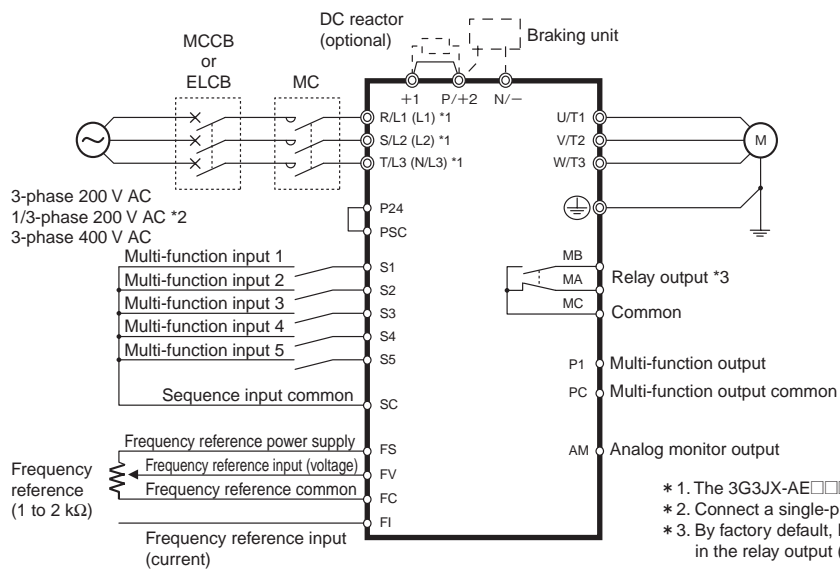

Dimensions

(Unit: mm)

- 3G3JX-A2002
- 3G3JX-A2004
- 3G3JX-A2007
- 3G3JX-AE002
- 3G3JX-AE004

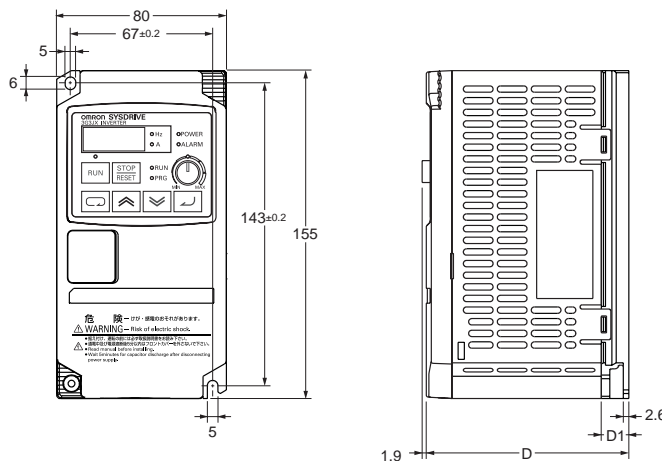

Rated voltage	Model 3G3JX	Dimensions (mm)	
		D	D1
3phase 200 V AC	A2002	95.5	13
	A2004	109.5	27
	A2007	132.5	50
1/3phase 200 V AC	AE002	95.5	13
	AE004	109.5	27

Simple, Compact Inverters JX-Series

3G3JX-A4004
3G3JX-AE007

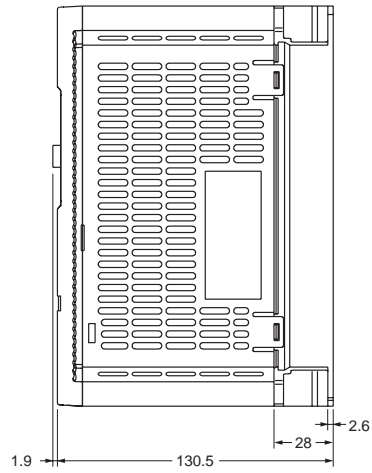
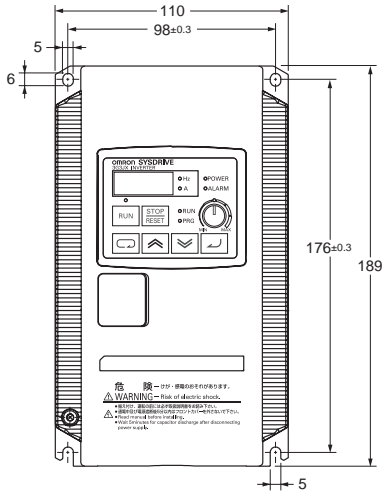

3G3JX-A2015
3G3JX-A2022
3G3JX-A2037
3G3JX-A4007
3G3JX-A4015
3G3JX-A4022
3G3JX-A4037
3G3JX-AE015
3G3JX-AE022

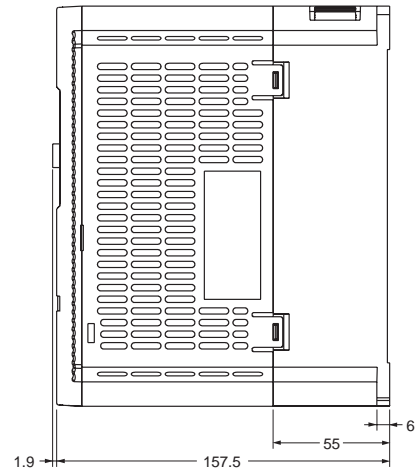
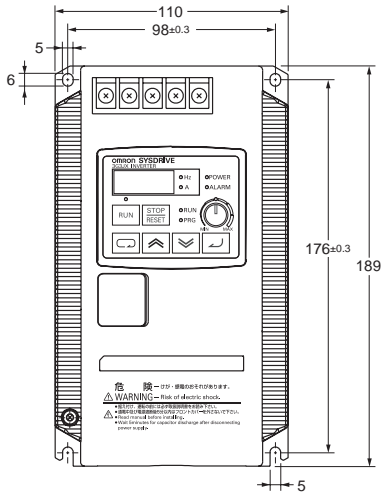

3G3JX-A2055
3G3JX-A2075
3G3JX-A4055
3G3JX-A4075

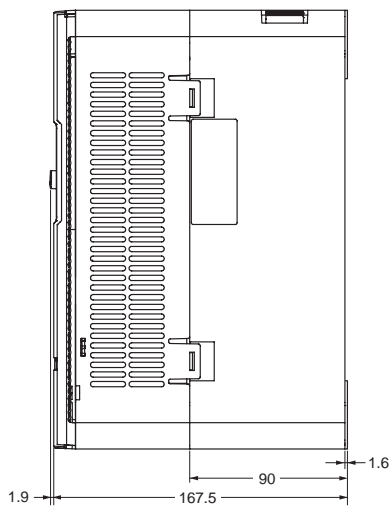
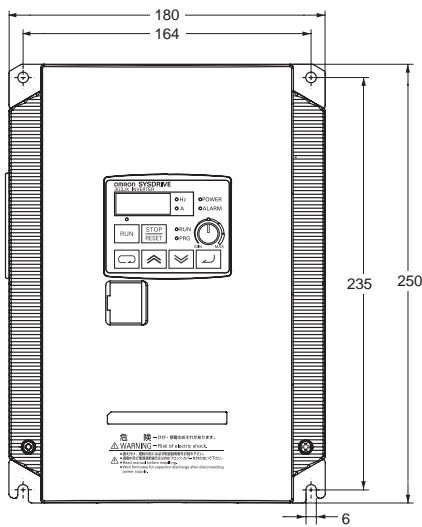

Options

Regenerative Braking Unit 3G3AX-RBU□□

Used with a Braking Resistor when regenerative energy is produced in the 3G3JX.

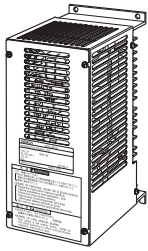

● Connection Example

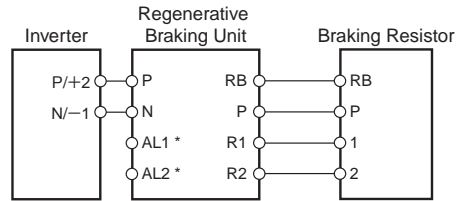

* The alarm output terminals for the Regenerative Braking Unit. Provide a circuit to turn off the primary power supply for the Inverter when the temperature relay of the built-in resistor or optional Braking Resistor is activated.

Note: When mounting an external Braking Resistor, remove the built-in resistor.

● Specifications

Built-in Resistance Type (3G3AX-RBU21/-RBU22/-RBU41)

Class Model name (3G3AX-)	3-phase 200 V class		3-phase 400 V class	
	RBU21	RBU22	RBU41 ^{*1}	
Connection resistance	17 Ω min.	17 Ω min.	34 Ω min.	
Operating voltage ON/OFF	ON: 362.5±5 V, OFF: 355±5 V (-5% or -10% setting available)		ON: 725±5 V, OFF: 710±5 V (-5% or -10% setting available)	
Operation indication	LED ON (Lit)			
Maximum number of units for parallel interlocking operation ^{*2}	5 units			
Built-in resistor	Built-in resistance	120 W 180	120 W 20	120 W 180 × 2 main elements
	Allowable consecutive ON time	10s max.	0.5s max.	10s max.
	Allowable operation cycle	Cycle 1/10 (10 s ON/90 s OFF)	Cycle 1/80 (0.5 s ON/40 s OFF)	Cycle 1/10 (10 s ON/90 s OFF)
	Power consumption	Instantaneous: 0.73 kW Short-time rating: 120 W	Instantaneous: 6.6 kW Short-time rating: 120 W	Instantaneous: 1.46 kW Short-time rating: 240 W
Protective functions	Built-in Resistor Overheat protection	Built-in relay specifications		
		<ul style="list-style-type: none"> The temperature relay operates if the built-in resistor reaches approx. 200 °C and recovers at approx. 170 °C max. Built-in temperature fuse (recovery impossible)^{*3} Contact rating 250 VAC 200 mA (R load) 12 VDC 500 mA (R load) 42 VDC 200 mA (R load) Minimum load 1mA 		
Operating environment	Ambient temperature	-10 to 50 °C		
	Ambient storage temperature	-20 °C to 65 °C (short-time temperature during transport)		
	Humidity	20% to 90% (with no condensation)		
	Vibration	5.9 m/s ² (0.6 G) 10 to 55 Hz		
	Location	At a maximum altitude of 1,000 m; indoors (without corrosive gases or dust)		
Paint color	Munselle 5Y7/1 (cooling fan: aluminum color)			

*1 To use the Regenerative Braking Unit for 1.5 kW or more 200 V class or the 2.2 kW or more 400 V class, be sure to remove the built-in resistor.

*2 Set the DIP switches.

*3 The built-in resistor incorporates a temperature fuse. If the alarm terminal is not connected, the fuse may blow out in order to prevent the resistor burning due to overheating. If the fuse blows out, the built-in resistor must be replaced.

● Dimensions (Unit: mm)

3G3AX-RBU21/-RBU22/-RBU41

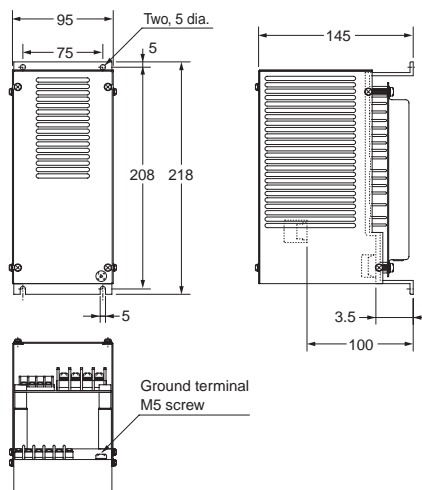

Simple, Compact Inverters JX-Series

Braking Resistor 3G3AX-RB□□□□

Consumes the regenerative motor energy with a resistor to reduce deceleration time.

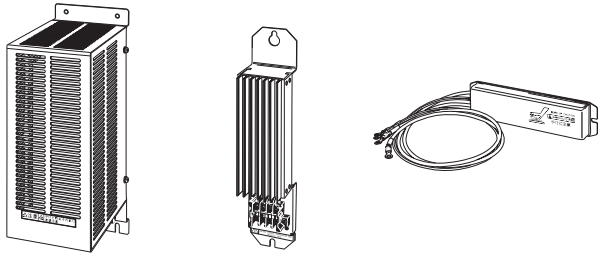

● Connection Example

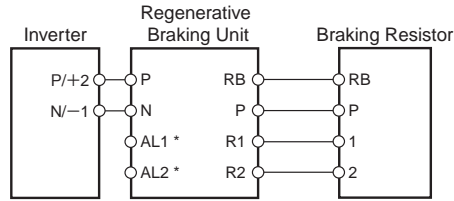

* The alarm output terminals for the Regenerative Braking Unit. Provide a circuit to turn off the primary power supply for the Inverter when the temperature relay of the built-in resistor or optional Braking Resistor is activated.

Note: When mounting an external Braking Resistor, remove the built-in resistor.

● Specifications

Model		Compact type (3G3AX-RBA□□□□)				Standard type (3G3AX-RBB□□□□)				Medium capacity type (3G3AX-RBC□□□□)		
		1201	1202	1203	1204	2001	2002	3001	4001	4001	6001	12001
Resistance	Capacity	120W	120W	120W	120W	200W	200W	300W	400W	400W	600W	1200W
	Resistance (Ω)	180	100	50	35	180	100	50	35	50	35	17
Allowable braking frequency (%)		5	2.5	1.5	1.0	10	7.5	7.5	7.5	10	10	10
Allowable continuous braking time (s)		20	12	5	3	30	30	30	20	10	10	10
Weight (kg)		0.27	0.27	0.27	0.27	0.97	0.97	1.68	2.85	2.5	3.6	6.5
Fault detection function		Built-in thermal (contact capacity 240 VAC, 2 A max., minimum current 5 mA), Normally ON (NC) contact Built-in temperature fuse (non-recovery)							Built-in temperature relay, Normally ON (NC) Contact capacity: 240 VAC 3 A (R load), 0.2 A (L load), 36 VDC 2 A (R load)			
General specification	Ambient temperature	-10 to 50 °C										
	Humidity	20% to 90% (RH) with no condensation										
	Vibration	5.9 m/s (0.6 G) 10 to 55 Hz Complies with JISC0911										
	Location	At a maximum altitude of 1,000 m; indoors (without corrosive gases or dust)										
	Cooling method	Self-cooling										

● Dimensions (Unit: mm)

3G3AX-RBA

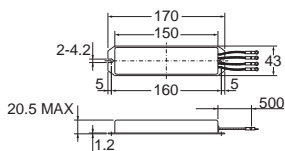

3G3AX-RBB

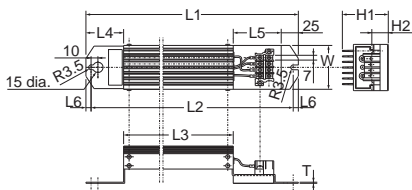

3G3AX-RBC4001

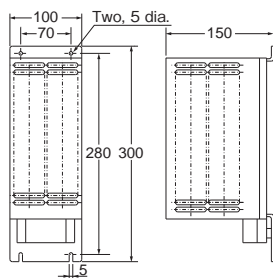

3G3AX-RBC6001

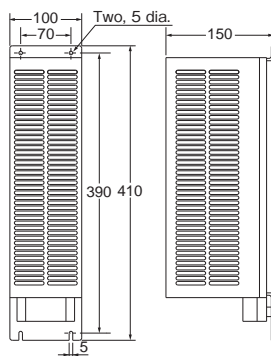

3G3AX-RBC12001

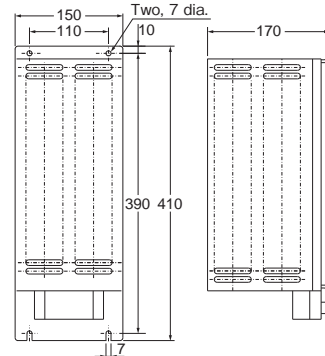

Model	Dimensions (mm)					
	L1	L2	L3	L4	L5	L6
3G3AX-RBB2001	310	295	160	55	70	7.5
3G3AX-RBB2002	310	295	160	55	70	7.5
3G3AX-RBB3001	470	455	320	55	70	7.5
3G3AX-RBB4001	435	422	300	50	60	6.5

Model	Dimensions (mm)				Weight (kg)	Screw size
	H1	H2	W	T		
3G3AX-RBB2001	67	12	64	1.6	0.97	M3.5
3G3AX-RBB2002	67	12	64	1.6	0.97	
3G3AX-RBB3001	67	12	64	1.6	1.68	
3G3AX-RBB4001	94	15	76	2	2.85	

Radio Noise Filter 3G3AX-ZCL□

Connected to the inverter input/output cables to reduce noise coming into the inverter from the power supply line and noise flowing from the inverter into the power supply line.

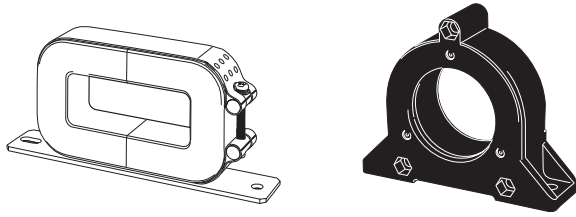

● Connection Example

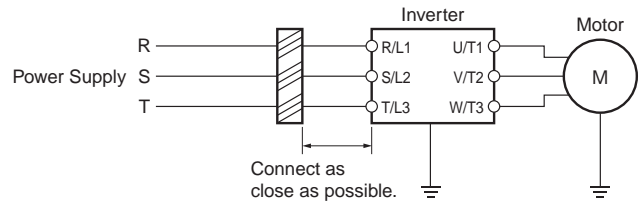

- Note 1: Wind each of three phase wires in the same direction.
 Note 2: Can be used on both the input and output sides of the Inverter.

● Specifications

3G3AX-ZCL1

Applicable Inverter capacity (kW)	200 V class				400 V class			
	Input		Output		Input		Output	
	No. of filters	No. of penetrations	No. of filters	No. of penetrations	No. of filters	No. of penetrations	No. of filters	No. of penetrations
0.2	1	4	1	4	1	4	1	4
0.4	1	4	1	4	1	4	1	4
0.75	1	4	1	4	1	4	1	4
1.5	1	4	1	4	1	4	1	4
2.2	1	4	1	4	1	4	1	4
3.7	1	4	1	4	1	4	1	4
5.5	1	4	1	4	1	4	1	4
7.5	1	4	1	4	1	4	1	4

3G3AX-ZCL2

Applicable Inverter capacity (kW)	200 V class				400 V class			
	Input		Output		Input		Output	
	No. of filters	No. of penetrations	No. of filters	No. of penetrations	No. of filters	No. of penetrations	No. of filters	No. of penetrations
0.2	1	4	1	4	1	4	1	4
0.4	1	4	1	4	1	4	1	4
0.75	1	4	1	4	1	4	1	4
1.5	1	4	1	4	1	4	1	4
2.2	1	4	1	4	1	4	1	4
3.7	1	4	1	4	1	4	1	4
5.5	N/A		N/A		1	4	1	4
7.5	N/A		N/A		1	4	1	4

● Dimensions (Unit: mm)

3G3AX-ZCL1

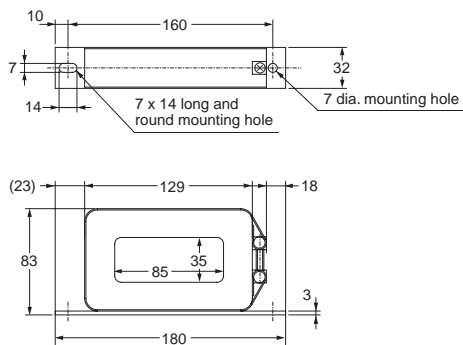

3G3AZ-ZCL2

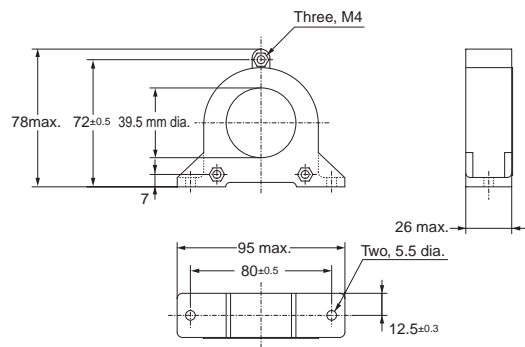

Simple, Compact Inverters JX-Series

Input Noise Filter 3G3AX-NFI□□

Reduces noise coming into the inverter from the power supply line and noise flowing from the inverter into the power supply line. Connect as close to the Inverter as possible.

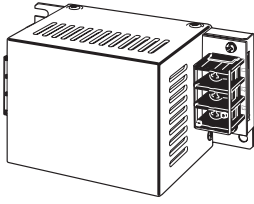

● Connection Example

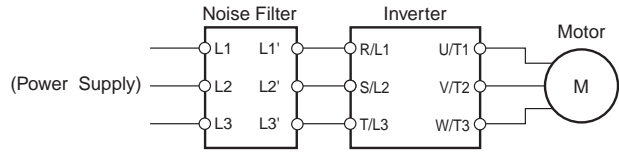

● Specifications

Power supply	Model	Applicable Inverter capacity (kW)	Rated input current In (A) at an ambient temperature of 50 °C	Power loss (W)	Leakage current (mA/phase) at 60 Hz	Case enclosure rating	Terminal size	Wire dia.	Weight (kg)
3-phase 200 VAC	3G3AX-NFI21	0.2 to 0.75	3 × 6A	3	<1.5 (250V)	Plastic, IP00	M4	1.25mm ²	0.5
	3G3AX-NFI22	1.5	3 × 10A	4	<1.5 (250V)	Plastic, IP00	M4	2mm ²	0.6
	3G3AX-NFI23	2.2, 3.7	3 × 20A	6	<1.5 (250V)	Plastic, IP00	M4	2mm ² , 3.5mm ²	0.7
	3G3AX-NFI24	5.5	3 × 30A	9	<1.5 (250V)	Plastic, IP00	M4	5.5mm ²	0.8
	3G3AX-NFI25	7.5	3 × 40A	12	<1.5 (250V)	Plastic, IP00	M5	8mm ²	1.4
3-phase 400 VAC	3G3AX-NFI41	0.4 to 2.2	3 × 7A	2	<7.5 (480V)	Plastic, IP00	M4	1.25mm ² , 2mm ²	0.7
	3G3AX-NFI42	3.7	3 × 10A	4	<7.5 (480V)	Plastic, IP00	M4	2mm ²	0.7
	3G3AX-NFI43	5.5, 7.5	3 × 20A	6	<7.5 (480V)	Plastic, IP00	M4	2mm ² , 3.5mm ²	0.7

● Dimensions (Unit: mm)

3G3AX-NFI21
3G3AX-NFI22

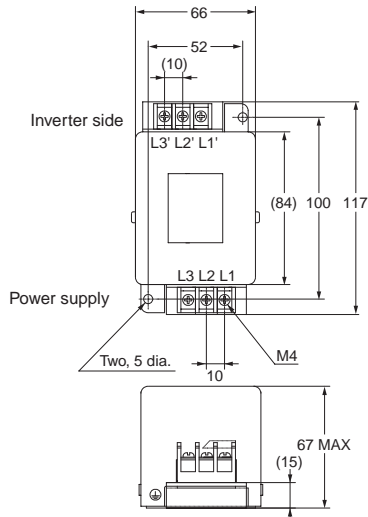

3G3AX-NFI23/3G3AX-NFI24
3G3AX-NFI41/3G3AX-NFI42
3G3AX-NFI43

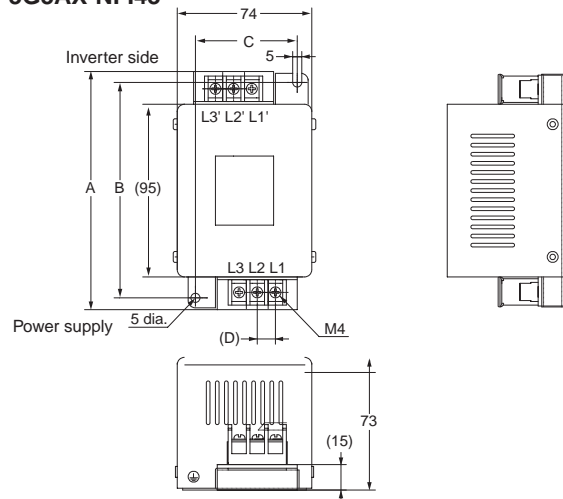

3G3AX-NFI25

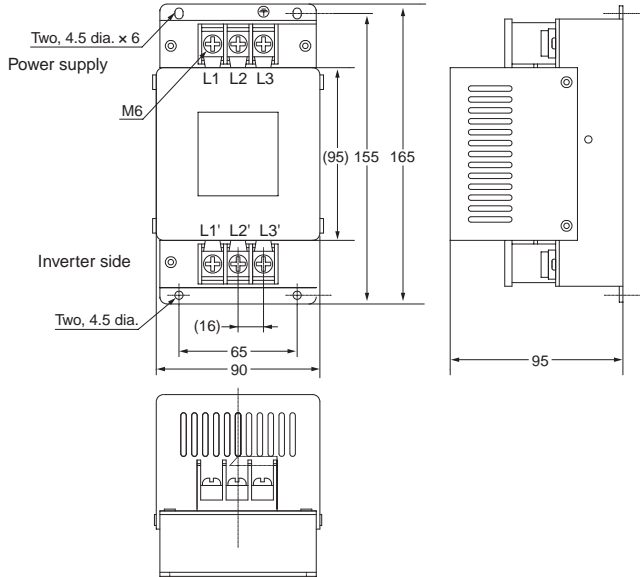

Model	Dimensions (Unit: mm)			
	A	B	C	D
3G3AX-NFI23	128	118	56	10
3G3AX-NFI24	144	130	56	11
3G3AX-NFI41	144	130	56	11
3G3AX-NFI42	144	130	56	11
3G3AX-NFI43	144	130	56	11

EMC-compatible Noise Filter 3G3AX-EFI□□

Separately installed option used to comply with the EC's EMC Directives. Select a filter appropriate for the Inverter model.

●Connection Example

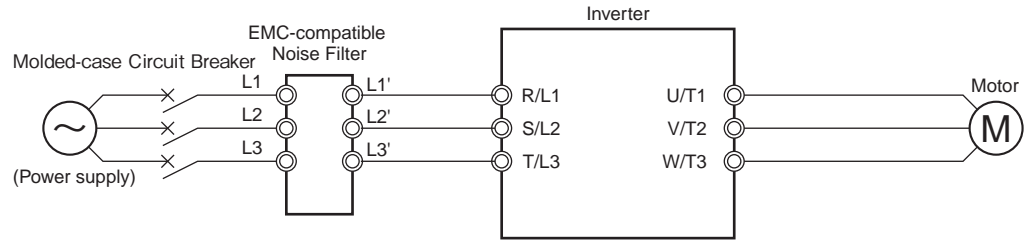
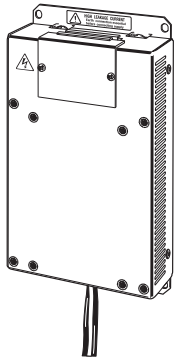

●Specifications

Power supply	Model	Applicable Inverter capacity (kW)			Input current in (A)	Leakage current (mA/phase at 60 Hz)	Case, Enclosure rating	Screw size	Wire size	Weight (kg)	
		1-phase 200 V	3-phase 200 V	3-phase 400 V							
1-phase 200 VAC	3G3AX-EFIB1	0.2, 0.4	---	---	2 × 6A	15	Aluminum, IP20	M4	1.3mm ²	0.43	
	3G3AX-EFIB2	0.75	---	---	2 × 10A	15			2.1mm ²	0.6	
	3G3AX-EFIB3	1.5, 2.2	---	---	2 × 21A	15			3.3 to 5.3mm ²	0.88	
3-phase 200 VAC	3G3AX-EFI21	---	0.2, 0.4	---	3 × 4A	15	Aluminum, IP20	M4	1.3mm ²	0.56	
	3G3AX-EFI22	---	0.75	0.4 to 1.5	3 × 5.2A	16			1.3mm ²	0.72	
	3G3AX-EFI23	---	1.5, 2.2	2.2, 3.7	3 × 14A	16			2.1mm ²	1.2	
	3G3AX-EFI24	---	3.7	---	3 × 22A	16			3.3mm ²	1.3	
	3G3AX-EFI25	---	5.5, 7.5	5.5, 7.5	3 × 40A	90			M5	3.3 to 8.4mm ²	2.4
3-phase 200/400 VAC	3G3AX-EFI41	---	0.4, 0.75	0.4 to 2.2	3 × 7A	150	Plastic, IP00	M4	1.25mm ² , 2mm ²	0.7	
	3G3AX-EFI42	---	1.5	3.7	3 × 10A	150			2mm ²	0.7	
	3G3AX-EFI43	---	2.2, 3.7	5.5, 7.5	3 × 20A	170			M5	2mm ² , 3.5mm ²	1.0
	3G3AX-EFI44	---	5.5	---	3 × 30A	170				5.5mm ²	1.3
	3G3AX-EFI45	---	7.5	---	3 × 40A	170				8mm ²	1.4

●Dimensions (Unit: mm)

3G3AX-EFIB1
3G3AX-EFI21

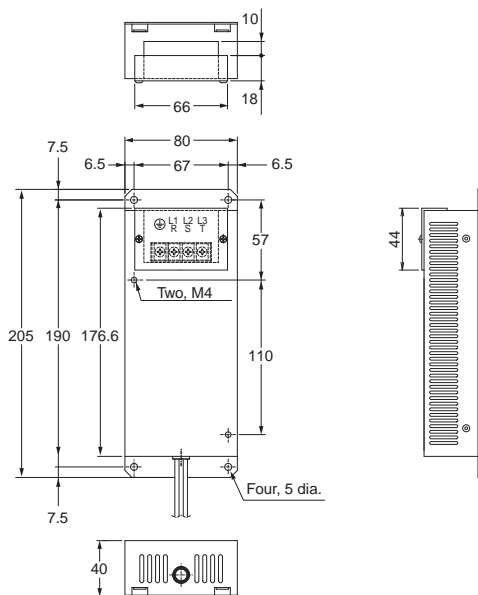

3G3AX-EFIB2
3G3AX-EFI22

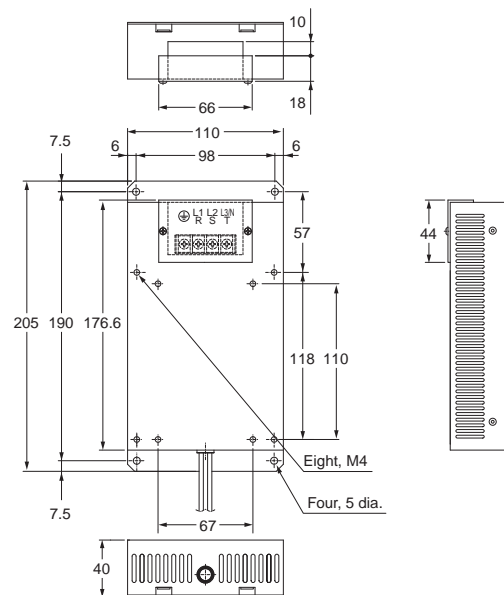

Simple, Compact Inverters JX-Series

3G3AX-EFIB3
3G3AX-EFI23

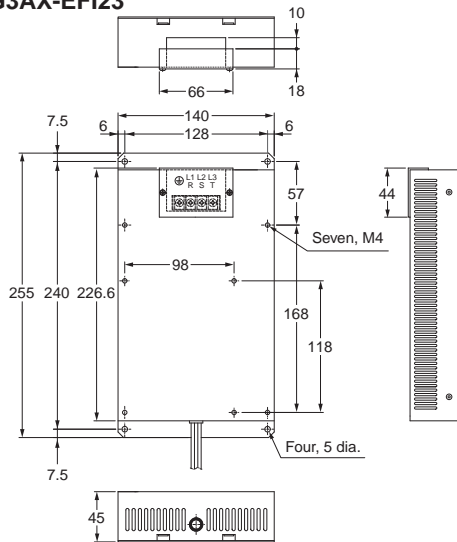

3G3AX-EFI24

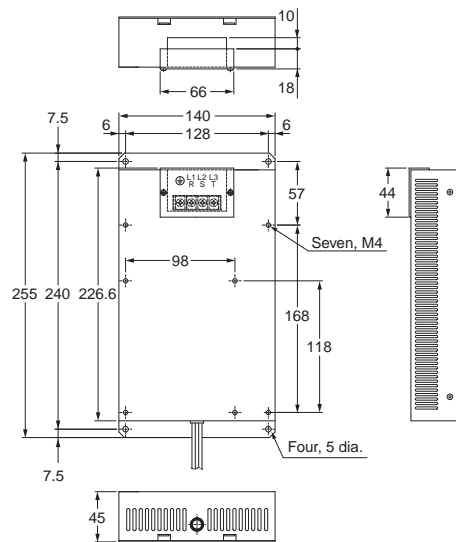

3G3AX-EFI25

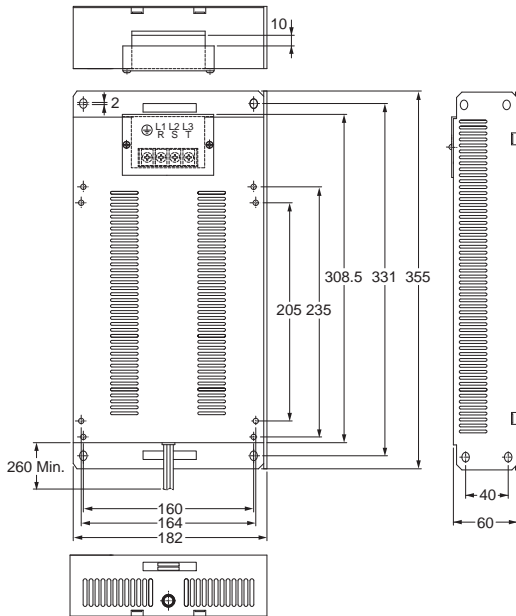

3G3AX-EFI41
3G3AX-EFI42

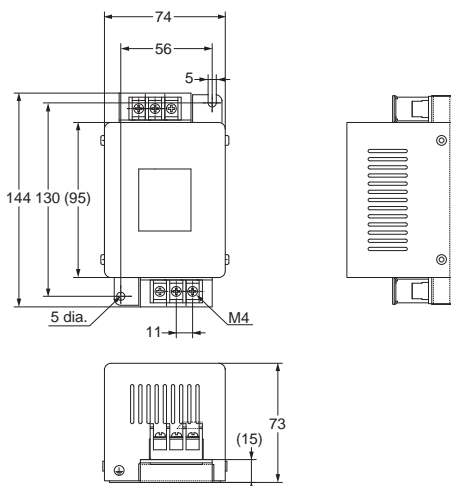

3G3AX-EFI43/3G3AX-EFI44
3G3AX-EFI45

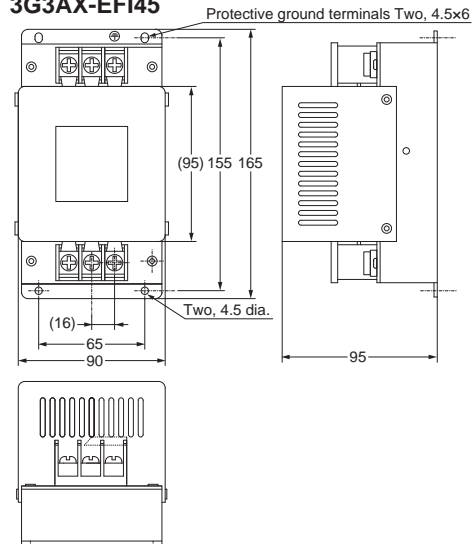

Output Noise Filter 3G3AX-NFO□□

Reduces noise generated by the Inverter. Connect as close to the Inverter as possible.

●Connection Example

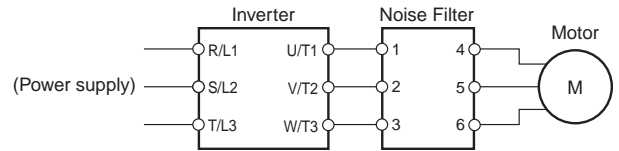
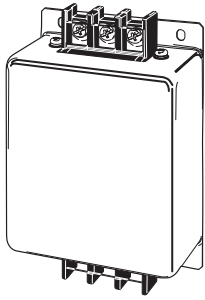

●Specifications

Power supply	Model	Rated current (A)	Applicable motor (kW)		External Dimensions (H X W X D) (mm)	Weight (kg)
			200 V class	400 V class		
3-phase,3-wire Rated voltage 500 VAC	3G3AX-NFO01	6	to 0.75	to 2.2	156 × 95 × 50	0.7
	3G3AX-NFO02	12	1.5, 2.2	3.7	176 × 110 × 70	0.9
	3G3AX-NFO03	25	3.7, 5.5	5.5, 7.5	154 × 160 × 120	2.1
	3G3AX-NFO04	50	7.5	---	210 × 200 × 150	3.7

●Dimensions (Unit: mm)

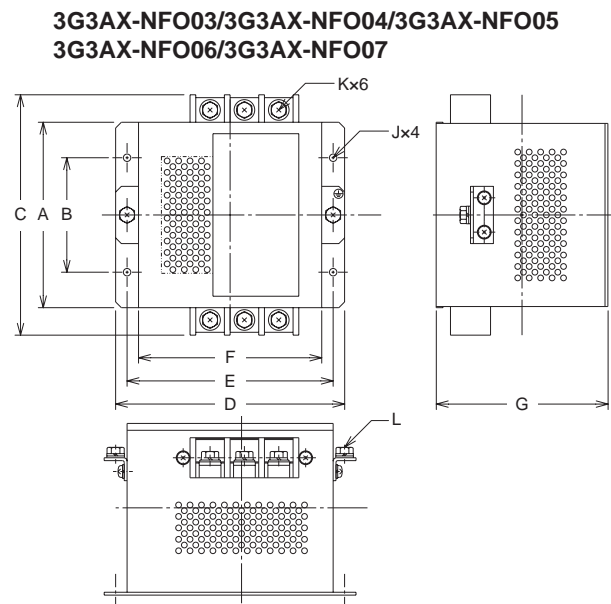
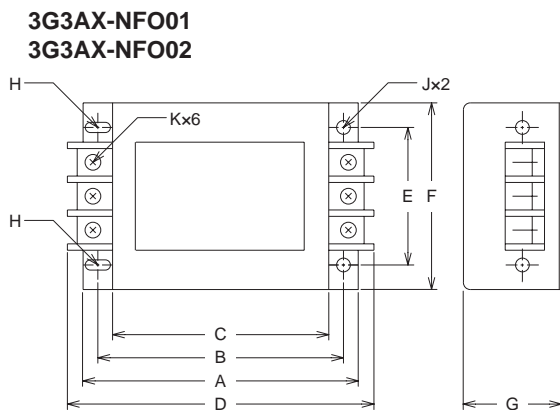

Model	A	B	C	D	E	F	G	H	J	K	L
3G3AX-NFO01	140	125	110	156	70	95	50	R: 2.25mm Length: 6mm	4.5 dia. mm	M4	---
3G3AX-NFO02	160	145	130	176	80	110	70	R: 2.75mm Length: 7mm	5.5 dia. mm	M4	---
3G3AX-NFO03	112	80	154	160	145	130	120	---	6.5 dia. mm	M4	---
3G3AX-NFO04	162	100	210	200	180	160	150	---	6.5 dia. mm	M5	M5

Simple, Compact Inverters JX-Series

DC Reactor 3G3AX-DL□□□□

Used to suppress harmonic current generated from the Inverter.

Suppresses harmonic current better than the AC Reactor and can be used with the AC Reactor.

●Connection Example

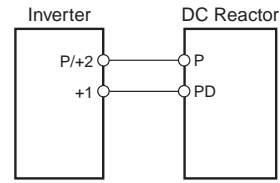
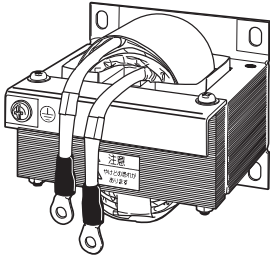

●Specifications

Inverter Input power supply	Model	Figure No.	Applicable Inverter	Dimensions (mm) Bmax: coil dimensions									Weight (kg)	Standard applicable wire	
				W	D	H	A	B	X	Y	C	K			
3/1-phase 200 VAC	3G3AX-DL2002	1	0.2	66	90	98	---	85	56	72	5.2 × 8	M4	0.8	1.25 mm ² min.	
	3G3AX-DL2004		0.4	66	90	98	---	95	56	72	5.2 × 8	M4	1.0	1.25 mm ² min.	
	3G3AX-DL2007		0.75	66	90	98	---	105	56	72	5.2 × 8	M4	1.3	2 mm ² min.	
	3G3AX-DL2015		1.5	66	90	98	---	115	56	72	5.2 × 8	M4	1.6	2 mm ² min.	
	3G3AX-DL2022		2.2	86	100	116	---	105	71	80	6 × 9	M4	2.1	2 mm ² min.	
	3G3AX-DL2037		3.7	86	100	118	---	120	71	80	6 × 9	M4	2.6	3.5 mm ² min.	
	3G3AX-DL2055		5.5	111	100	210	---	110	95	80	7 × 11	M5	3.6	8 mm ² min.	
3-phase 400 VAC	3G3AX-DL2075	2	7.5	111	100	212	---	120	95	80	7 × 11	M6	3.9	14 mm ² min.	
	3G3AX-DL4004		1	0.4	66	90	98	---	85	56	72	5.2 × 8	M4	0.8	1.25 mm ² min.
	3G3AX-DL4007			0.75	66	90	98	---	95	56	72	5.2 × 8	M4	1.1	1.25 mm ² min.
	3G3AX-DL4015			1.5	66	90	98	---	115	56	72	5.2 × 8	M4	1.6	2 mm ² min.
	3G3AX-DL4022			2.2	86	100	116	---	105	71	80	6 × 9	M4	2.1	2 mm ² min.
	3G3AX-DL4037			3.7	86	100	116	---	120	71	80	6 × 9	M4	2.6	2 mm ² min.
	3G3AX-DL4055			5.5	111	100	138	---	110	95	80	7 × 11	M4	3.6	3.5 mm ² min.
3G3AX-DL4075	7.5	111		100	138	---	115	95	80	7 × 11	M4	3.9	3.5 mm ² min.		

●Dimensions (Unit: mm)

Fig. 1

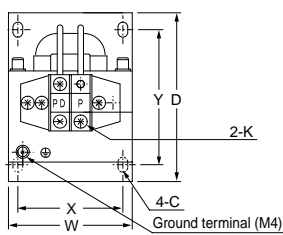
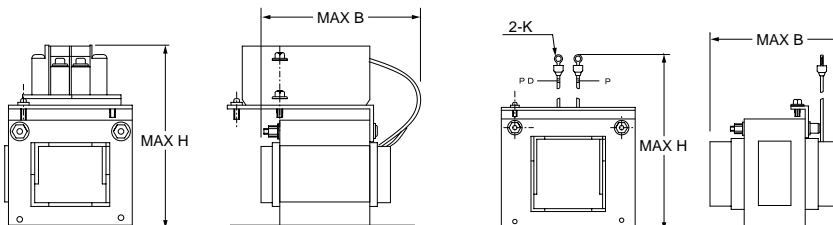
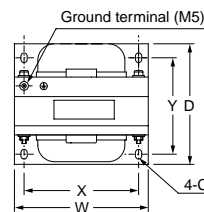

Fig. 2



AC Reactor 3G3AX-AL□□□□

Connect the AC Reactor if the capacity of the power supply is much larger than that of the Inverter or the power factor is required to be improved.

●Connection Example

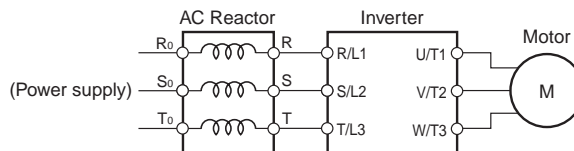
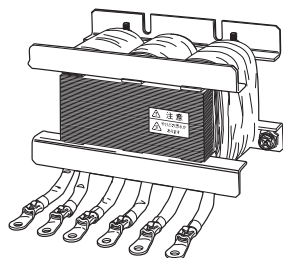

●Specifications

Power supply	Model	Applicable Inverter capacity (kw)	Dimensions (mm)								Weight (kg)
			A	C	D	E	H	H1	X	Y	
3-phase 200 VAC	3G3AX-AL2025	0.2 to 1.5	120	82	60	40	150	94	50	67	2.8
	3G3AX-AL2055	2.2, 3.7	120	98	60	40	150	94	50	75	4.0
	3G3AX-AL2110	5.5, 7.5	150	103	70	55	170	108	60	80	5.0
3-phase 400 VAC	3G3AX-AL4025	0.4 to 1.5	130	82	60	40	150	94	50	67	2.7
	3G3AX-AL4055	2.2, 3.7	130	98	60	40	150	94	50	75	4.0
	3G3AX-AL4110	5.5, 7.5	150	116	75	55	170	106	60	98	6.0

●Dimensions (Unit: mm)

3G3AX-AL2025
3G3AX-AL2055

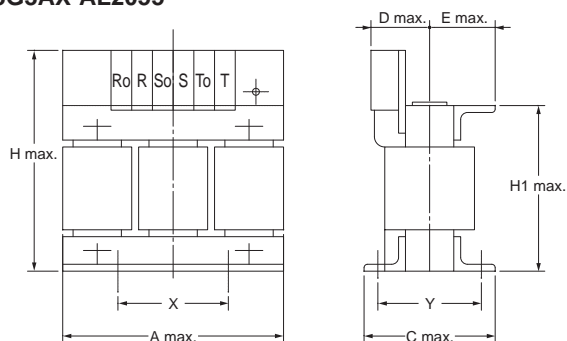

3G3AX-AL2110

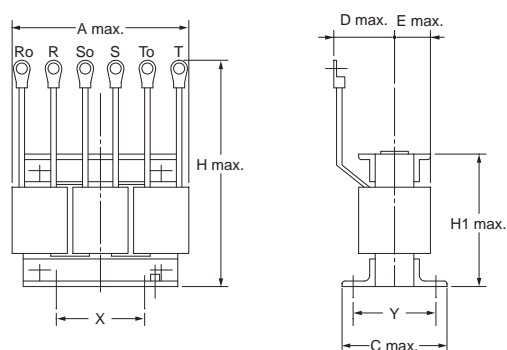

3G3AX-AL4025/3G3AX-AL4055
3G3AX-AL4110

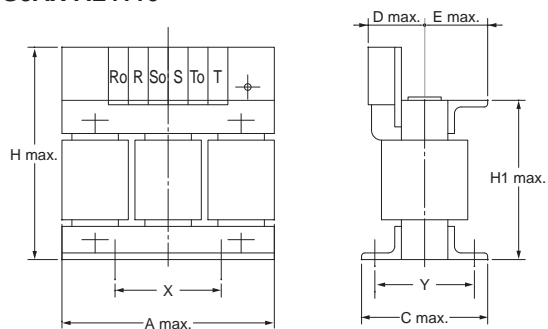

Simple, Compact Inverters JX-Series

Digital Operator 3G3AX-OP01

Used to set parameters, perform various monitoring, and start and stop the Inverter.



●Cables

3G3AX-OPCN□

Used to install the Digital Operator away from the Inverter.

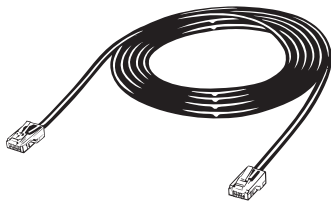

3G3AX-OPCN1 (Cable length: 1 m)

3G3AX-OPCN3 (Cable length: 3 m)

●Dimensions (Unit: mm)

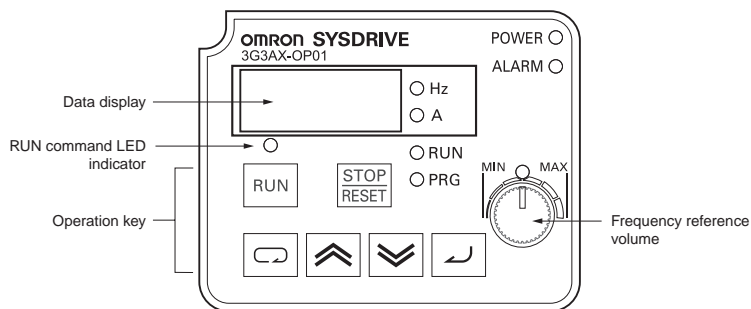

External Dimensions	Height (55 mm) X Width (70 mm) X Depth (10 mm)
----------------------------	--

Ordering Information

■System Configuration.....	16
■Interpreting Model Numbers	17
■Ordering Information	17
3G3JX Inverter Models	17
Related Options	17
Software.....	21
■Overview of Inverter Selection	22
■Related Manuals	26
■Other Products in the Inverter Series	26

SyMac® is a trademark or registered trademark of OMRON Corporation in Japan and other countries for OMRON factory automation products.

Windows is registered trademarks of Microsoft Corporation in the USA and other countries.

EtherCAT® is a registered trademark and patented technology, licensed by Beckhoff Automation GmbH, Germany.

Other company names and product names in this document are the trademarks or registered trademarks of their respective companies.

Simple, Compact Inverters JX-Series

System Configuration

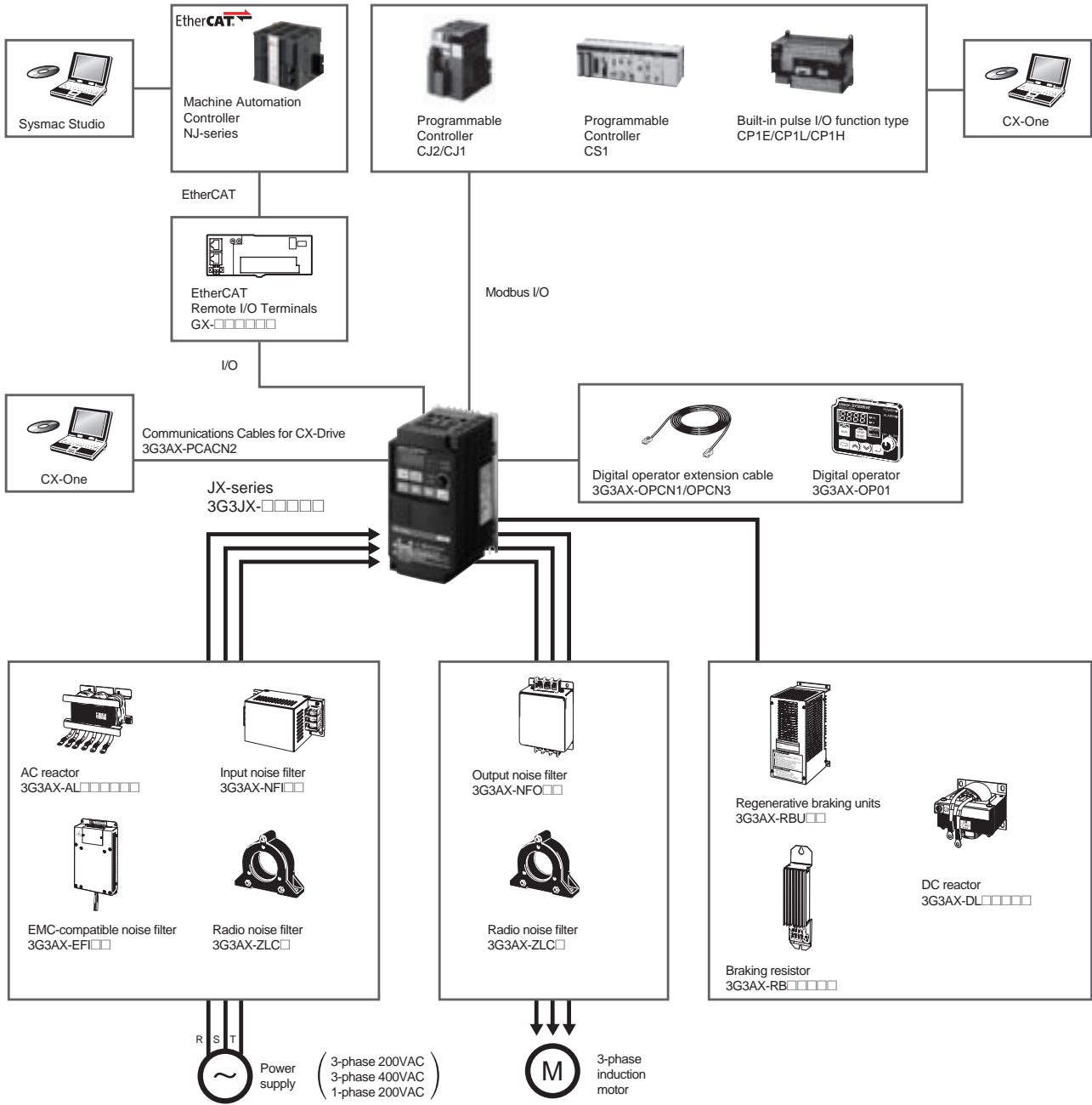

Interpreting Model Numbers

3G3JX-A□□□□

3G3JX

Voltage Class

2	3-phase 200 V AC
4	3-phase 400 V AC
E	1-/3-phase 200 V AC

Maximum Motor Capacity

002	0.2kW	022	2.2kW
004	0.4kW	037	3.7kW
007	0.75kW	055	5.5kW
015	1.5kW	075	7.5kW

Ordering Information

3G3JX Inverter Models

Rated voltage	Enclosure rating	Max. applicable motor capacity	Model
3-phase 200 V AC	IP20	0.2kW	3G3JX-A2002
		0.4kW	3G3JX-A2004
		0.75kW	3G3JX-A2007
		1.5kW	3G3JX-A2015
		2.2kW	3G3JX-A2022
		3.7kW	3G3JX-A2037
		5.5kW	3G3JX-A2055
7.5kW		3G3JX-A2075	
1-/3-phase 200 V AC		0.2kW	3G3JX-AE002
		0.4kW	3G3JX-AE004
		0.75kW	3G3JX-AE007
		1.5kW	3G3JX-AE015
3-phase 400 V AC		2.2kW	3G3JX-AE022
		0.4kW	3G3JX-A4004
	0.75kW	3G3JX-A4007	
	1.5kW	3G3JX-A4015	
	2.2kW	3G3JX-A4022	
	3.7kW	3G3JX-A4037	
	5.5kW	3G3JX-A4055	
7.5kW	3G3JX-A4075		

Related Options

Name	Specifications		Model
Regenerative Braking Units	3-phase 200 VAC	General purpose with Braking resistor	3G3AX-RBU21
		High Regeneration purpose with Braking resistor	3G3AX-RBU22
	3-phase 400 VAC	General purpose with Braking resistor	3G3AX-RBU41
Braking Resistor	Compact type	Resistor 120 W, 180 Ω	3G3AX-RBA1201
		Resistor 120 W, 100 Ω	3G3AX-RBA1202
		Resistor 120 W, 50 Ω	3G3AX-RBA1203
		Resistor 120 W, 35 Ω	3G3AX-RBA1204
	Standard type	Resistor 200 W, 180 Ω	3G3AX-RBB2001
		Resistor 200 W, 100 Ω	3G3AX-RBB2002
		Resistor 300 W, 50 Ω	3G3AX-RBB3001
		Resistor 400 W, 35 Ω	3G3AX-RBB4001
	Medium capacity type	Resistor 400 W, 50 Ω	3G3AX-RBC4001
		Resistor 600 W, 35 Ω	3G3AX-RBC6001
		Resistor 1200 W, 17 Ω	3G3AX-RBC12001

Simple, Compact Inverters JX-Series

Regenerative Braking Unit and Braking Resistor Combination

(1) Inverter specifications (choose voltage, capacity, and model)

The content noted in the table assumes the case of combining one Inverter and one motor of the same capacity.

(2) Select the %ED.

Use the %ED that is equivalent to or lower than the value shown.

(3) This shows the model and number of regenerative braking units and braking resistors.

(4) This provides a summary of the connection configuration of the regenerative braking unit and braking resistor.

Refer to the "Connection configuration"

(5) The specified conditions contain restrictions. Make sure there are not any issues

Inverter			Usage conditions		Regenerative braking unit		Braking resistor		Con- nec- tion con- figu- ration	Restrictions	
Voltage	Max. applicable motor capacity (kW)	Mode	%ED *1 (%)	Approx- imate braking torque (% *2)	Model	Num- ber of units	Model	Num- ber of units		Allow- able con- tinuous braking time (s)	Min. con- nectable resis- tance (Ω)
200-V Class	0.2	3G3JX-A2002 3G3JX-AE002	3.0%	220%	3G3AX-RBU21	1	Built-in Inverter	---	10	10	17
			10.0%	220%		1					
	0.4	3G3JX-A2004 3G3JX-AE004	3.0%	220%	3G3AX-RBU21	1	Built-in Inverter	---	10	10	17
			10.0%	220%		1					
	0.75	3G3JX-A2007 3G3JX-AE007	3.0%	120%	3G3AX-RBU21	1	Built-in Inverter	---	10	10	17
			10.0%	120%		1					
	1.5	3G3JX-A2015 3G3JX-AE015	2.5%	110%	3G3AX-RBU21 *3	1	3G3AX-RBA1202	1	11	12	17
			10.0%	215%		1	3G3AX-RBC4001	1	11	10	17
	2.2	3G3JX-A2022 3G3JX-AE022	3.0%	150%	3G3AX-RBU21 *3	1	3G3AX-RBB3001	1	11	30	17
			10.0%	150%		1	3G3AX-RBC4001	1	11	10	17
	3.7	3G3JX-A2037	3.0%	125%	3G3AX-RBU21 *3	1	3G3AX-RBB4001	1	11	20	17
			10.0%	125%		1	3G3AX-RBC6001	1	11	10	17
	5.5	3G3JX-A2055	3.0%	120%	3G3AX-RBU21 *3	1	3G3AX-RBB3001	2	12	30	17
			10.0%	120%		1	3G3AX-RBC4001	2	12	10	17
7.5	3G3JX-A2075	3.0%	125%	3G3AX-RBU21 *3	1	3G3AX-RBB4001	2	12	20	17	
		10.0%	130%		1	3G3AX-RBC12001	1	11	10	17	
400-V Class	0.4	3G3JX-A4004	3.0%	220%	3G3AX-RBU41 *3	1	Built-in Inverter	---	21	10	34
			10.0%	220%		1					
	0.75	3G3JX-A4007	3.0%	220%	3G3AX-RBU41 *3	1	Built-in Inverter	---	21	10	34
			10.0%	220%		1					
	1.5	3G3JX-A4015	3.0%	120%	3G3AX-RBU41 *3	1	Built-in Inverter	---	21	10	34
			10.0%	120%		1					
	2.2	3G3JX-A4022	2.5%	150%	3G3AX-RBU41 *3	1	3G3AX-RBA1202	2	13	12	34
			10.0%	220%		1	3G3AX-RBC4001	2	13	10	34
	3.7	3G3JX-A4037	3.0%	175%	3G3AX-RBU41 *3	1	3G3AX-RBB3001	2	13	30	34
			10.0%	175%		1	3G3AX-RBC4001	2	13	10	34
	5.5	3G3JX-A4055	3.0%	120%	3G3AX-RBU41 *3	1	3G3AX-RBB3001	2	13	30	34
			10.0%	120%		1	3G3AX-RBC4001	2	13	10	34
	7.5	3G3JX-A4075	3.0%	125%	3G3AX-RBU41 *3	1	3G3AX-RBB4001	2	13	20	34
			10.0%	125%		1	3G3AX-RBC6001	2	13	10	34

*1 %ED shows the ratio that can be used for braking (deceleration time) among operating time of one task period.

*2 Approximate braking torque is shown in % of rating torque of the motor (100%).

*3 Please remove the built-in resistor.

Note: When the torque more than the approximate braking torque is required or it is necessary to use more frequently than %ED, the selection including the load calculation instead of the combination list is required.

Connection configuration

TYPE		
10	Braking unit with built-in resistor	<p>Braking unit with built-in resistor</p>
11	One braking unit One resistor	<p>Braking unit (Resistor mounted externally)</p>
12	One braking unit Two resistors in parallel	<p>Braking unit (Resistor mounted externally)</p>

TYPE		
13	One braking unit Two resistors in series	<p>Braking unit (Resistor mounted externally)</p>
21	Braking unit with two built-in resistors in series	<p>Braking unit with built-in resistor</p>

Simple, Compact Inverters JX-Series

Name	Specifications of Inverter		Model
	Voltage class	Applicable capacity (kW)	
Radio Noise Filter	3-phase 200 VAC	0.2	3G3AX-ZCL2
		0.4	
		0.75	
		1.1	
		2.2	
		3	
		5.5	
	1/3-phase 200 VAC	7.5	3G3AX-ZCL1 (3G3AX-ZCL2)
		0.2	3G3AX-ZCL2
		0.4	
		0.55	
		1.1	
	2.2		
	3-phase 400 VAC	0.75	3G3AX-ZCL2 (3G3AX-ZCL1)
		1.5	
2.2			
3			
4			
5.5			
Input Noise Filter	3-phase 200 VAC	7.5	3G3AX-NFI21
		0.2 to 0.75	3G3AX-NFI22
		1.5	3G3AX-NFI23
		2.2, 3.7	3G3AX-NFI24
		5.5	3G3AX-NFI25
	3-phase 400 VAC	7.5	3G3AX-NFI41
		0.4 to 2.2	3G3AX-NFI42
		3.7	3G3AX-NFI43
		5.5, 7.5	3G3AX-NFI44
EMC-compatible Noise Filter	1-phase 200 VAC	0.2, 0.4	3G3AX-EFI21
		0.75	3G3AX-EFI22
		1.5, 2.2	3G3AX-EFI23
	3-phase 200 VAC	0.2, 0.4	3G3AX-EFI24
		0.75	3G3AX-EFI25
		1.5, 2.2	3G3AX-EFI41
		3.7	3G3AX-EFI42
		5.5, 7.5	3G3AX-EFI43
		0.4, 0.75	3G3AX-EFI44
		1.5	3G3AX-EFI45
		2.2, 3.7	3G3AX-EFI22
		5.5	3G3AX-EFI23
		7.5	3G3AX-EFI24
	3-phase 200/400 VAC	0.4 to 1.5	3G3AX-EFI25
		2.2, 3.7	3G3AX-EFI41
		5.5, 7.5	3G3AX-EFI42
		0.4 to 2.2	3G3AX-EFI43
		3.7	3G3AX-EFI44
5.5, 7.5	3G3AX-EFI45		

Name	Specifications of Inverter		Model
	Voltage class	Applicable capacity (kW)	
Output Noise Filter	3-phase 400 VAC	Applicable motor 200-V Class: to 0.75 400-V Class: to 2.2	3G3AX-NFO01
		Applicable motor 200-V Class: 1.5, 2.2 400-V Class: 3.7	3G3AX-NFO02
		Applicable motor 200-V Class: 3.7, 5.5 400-V Class: 5.5, 7.5	3G3AX-NFO03
		Applicable motor 200-V Class: 7.5	3G3AX-NFO04
DC Reactor	1/3-phase 200 VAC	0.2	3G3AX-DL2002
		0.4	3G3AX-DL2004
		0.75	3G3AX-DL2007
		1.5	3G3AX-DL2015
		2.2	3G3AX-DL2022
		3.7	3G3AX-DL2037
		5.5	3G3AX-DL2055
	3-phase 400 VAC	7.5	3G3AX-DL2075
		0.4	3G3AX-DL4004
		0.75	3G3AX-DL4007
		1.5	3G3AX-DL4015
		2.2	3G3AX-DL4022
		3.7	3G3AX-DL4037
		5.5	3G3AX-DL4055
AC Reactor	3-phase 200 VAC	0.2 to 1.5	3G3AX-AL2025
		2.2, 3.7	3G3AX-AL2055
		5.5, 7.5	3G3AX-AL2110
	3-phase 400 VAC	0.4 to 1.5	3G3AX-AL4025
		2.2, 3.7	3G3AX-AL4055
		5.5, 7.5	3G3AX-AL4110

External Digital Operator

Name	Cable length	Model
Digital Operator	---	3G3AX-OP01
Connection cable	1m	3G3AX-OPCN1
	3m	3G3AX-OPCN3

Software

Name	Specifications	Specifications		Model
		Number of licenses	Media	
FA Integrated Tool Package CX-One Ver. 4.□	The CX-One is a comprehensive software package that integrates Support Software for OMRON PLCs and components. CX-One runs on following OS. Windows XP (Service Pack 3 or higher, 32-bit version) / Windows Vista (32-bit/64-bit version) / Windows 7 (32-bit/64-bit version) / Windows 8(32-bit/64-bit version) / Windows 8.1(32-bit/64-bit version) CX-One Version.4.□ includes CX-Drive Ver.2.□. For details, refer to the CX-One catalog (Cat. No.R134)	1 license *1	DVD *2	CXONE-AL01D-V4

*1 Multi licenses are available for the CX-One (3, 10, 30, or 50 licenses).

*2 The CX-One is also available on CD (CXONE-AL□□C-V4).

Communications Cable

Name	Specifications	Model
Communications cable for CX-Drive	USB Cable for JX and RX series (2m)	3G3AX-PCACN2

Simple, Compact Inverters JX-Series

Overview of Inverter Selection

For detail of Inverter selection, refer to the JX series User's Manual. (Man.No.I558).

Motor Capacity Selection

Before selecting an inverter, first the motor should be chosen. In selecting the motor, first calculate the load inertia for the applications, and then calculate the required capacity and torque.

Make a simple selection (use Formulas for the required output power)

This method of calculation helps select a motor by calculating the output (W) required by the motor to maintain its regular rotations. It does not include calculation of the effect of acceleration/deceleration. Therefore, make allowance for the calculated value to select a motor. This calculation method can be applied to applications that operate constantly such as fans, conveyers, agitators etc.

This calculation method must not be applied to the following applications:

- Those requiring instant start-up.
- Those that frequently repeat operation and stop.
- Those that have a large inertia at the power transfer part.
- Those that have an inefficient power transfer part.

● For Straight-Line Operation: Normal Power P_o [kW]

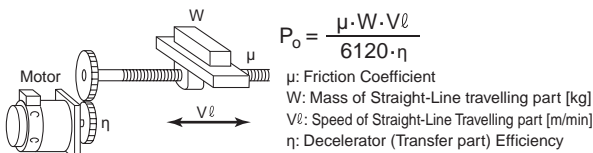

$$P_o = \frac{\mu \cdot W \cdot V\ell}{6120 \cdot \eta}$$

μ: Friction Coefficient
W: Mass of Straight-Line travelling part [kg]
Vℓ: Speed of Straight-Line Travelling part [m/min]
η: Decelerator (Transfer part) Efficiency

● For Rotating Operation: Normal Power P_o [kW]

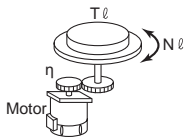

$$P_o \text{ [kW]} = \frac{2\pi \cdot T\ell \cdot N\ell}{60 \cdot \eta} \times 10^{-3}$$

Tℓ: Load Torque (Load Shaft) [N·m]
Nℓ: Load Shaft Rotation Speed [r/min]
η: Transfer part (η ≤ 1)

Detailed Selection Method (R.M.S Algorithm)

This method helps to select a motor by calculating the effective torque and maximum torque required to achieve a certain pattern of operation for the application. It selects a motor that is optimal for a particular operation pattern.

● Calculate the inertia with a Motor Shaft Conversion Value

Calculate inertias of all the components with the formula for inertia calculation shown below to convert them to a motor conversion value.

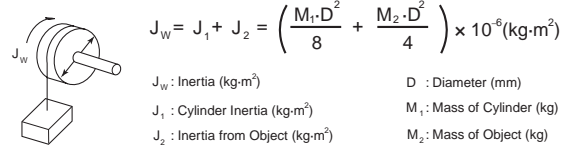

$$J_w = J_1 + J_2 = \left(\frac{M_1 \cdot D^2}{8} + \frac{M_2 \cdot D^2}{4} \right) \times 10^{-6} \text{ (kg·m}^2\text{)}$$

J_w: Inertia (kg·m²)
D: Diameter (mm)
J₁: Cylinder Inertia (kg·m²)
M₁: Mass of Cylinder (kg)
J₂: Inertia from Object (kg·m²)
M₂: Mass of Object (kg)

$$J_w = J_1 + J_2 + J_3 + J_4 = \left(\frac{M_1 \cdot D_1^2}{8} + \frac{M_2 \cdot D_2^2}{8} \cdot \frac{D_1^2}{D_2^2} + \frac{M_3 \cdot D_1^2}{4} + \frac{M_4 \cdot D_1^2}{4} \right) \times 10^{-6} \text{ (kg·m}^2\text{)}$$

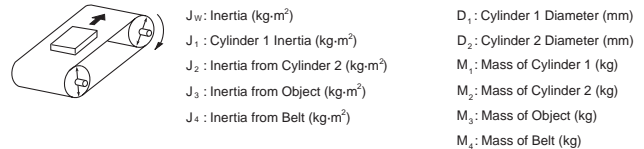

J_w: Inertia (kg·m²)
D₁: Cylinder 1 Diameter (mm)
D₂: Cylinder 2 Diameter (mm)
J₁: Cylinder 1 Inertia (kg·m²)
M₁: Mass of Cylinder 1 (kg)
J₂: Inertia from Cylinder 2 (kg·m²)
M₂: Mass of Cylinder 2 (kg)
J₃: Inertia from Object (kg·m²)
M₃: Mass of Object (kg)
J₄: Inertia from Belt (kg·m²)
M₄: Mass of Belt (kg)

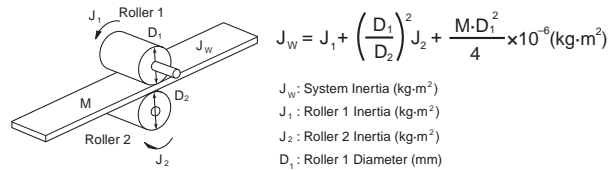

$$J_w = J_1 + \left(\frac{D_1}{D_2} \right)^2 J_2 + \frac{M \cdot D_1^2}{4} \times 10^{-6} \text{ (kg·m}^2\text{)}$$

J_w: System Inertia (kg·m²)
J₁: Roller 1 Inertia (kg·m²)
J₂: Roller 2 Inertia (kg·m²)
D₁: Roller 1 Diameter (mm)
D₂: Roller 2 Diameter (mm)
M: Work Equivalent Mass (kg)

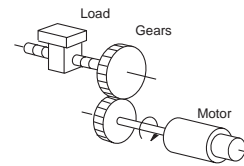

$$J_L = J_1 + G^2 (J_2 + J_w) \text{ (kg·m}^2\text{)}$$

J_L: Load Inertia of Motor Shaft Conversion (kg·m²)
J_w: Load Inertia (kg·m²)
J₁: Gear Inertia on Motor Side (kg·m²)
J₂: Gear Inertia on Load Side (kg·m²)
Z₁: Number of Gear Teeth on Motor Side
Z₂: Number of Gear Teeth on Load Side
Gear Ratio G = Z₁/Z₂

● Calculate Motor Shaft Conversion Torque and Effective Torque

Calculate the acceleration torque from the load torque calculated from both the motor shaft conversion value and the motor rotor inertia. Then Combine this acceleration torque and the Load torque calculated from the friction force and the external force that are applied to the load. Now you get the required torque to operate a motor.

Acceleration Torque

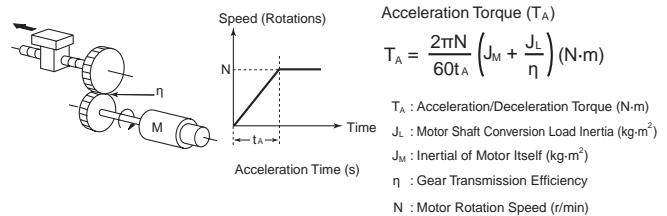

Acceleration Torque (T_A)

$$T_A = \frac{2\pi N}{60 t_A} \left(J_M + \frac{J_L}{\eta} \right) \text{ (N·m)}$$

T_A: Acceleration/Deceleration Torque (N·m)
J_L: Motor Shaft Conversion Load Inertia (kg·m²)
J_M: Inertia of Motor Itself (kg·m²)
η: Gear Transmission Efficiency
N: Motor Rotation Speed (r/min)

Motor Shaft Conversion Load Torque (External Force/Friction)

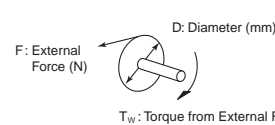

$$T_w = F \cdot \frac{D}{2} \times 10^{-3} \text{ (N·m)}$$

(Friction is generally,
F = μW
μ: Friction Coefficient
W: Mass of Moving Part)

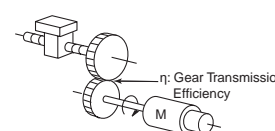

$$T_L = T_w \cdot \frac{G}{\eta} \text{ (N·m)}$$

T₁: Motor Shaft Conversion Load Torque (N·m)
T_w: Load Torque (N·m)
Z₁: Number of Gear Teeth on Motor Side
Z₂: Number of Gear Teeth on Load Side
Gear (Deceleration) Ratio G = Z₁/Z₂

• Calculation of Total Torque and Effective Torque

Effective Torque: T_{RMS} (N·m)

$$= \sqrt{\frac{\sum (T_i)^2 \cdot t_i}{\sum t_i}} = \sqrt{\frac{T_1^2 \cdot t_1 + T_2^2 \cdot t_2 + T_3^2 \cdot t_3 + T_4^2 \cdot t_4}{t_1 + t_2 + t_3 + t_4}}$$

Maximum Torque: $T_{MAX} = T_1 = T_A + T_L$

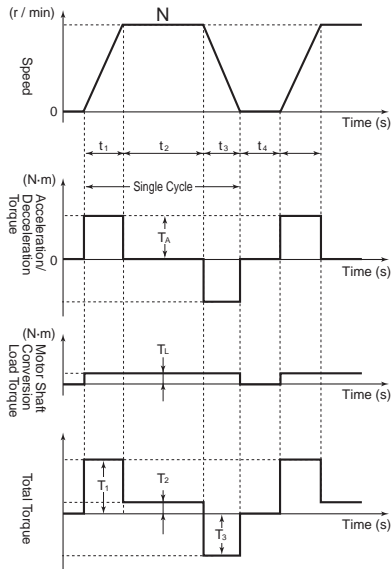

Note: Please make use of the Servo Motor selection software, which can calculate the motor shaft conversion inertia and effective/maximum torque, as above.

• Motor Selection

Use the formula below to calculate the motor capacity from the effective torque and the maximum torque that were obtained above. Select the larger of the two generated values as the motor capacity. Select a motor the capacity of which is larger than the calculated value and makes allowance for an error.

• Motor Capacity corresponding to Effective Torque

$$\text{Motor Capacity [kW]} = 1.048 \cdot N \cdot T_{RMS} \cdot 10^{-4}$$

N: Maximum Rotations (r/min)

• Motor Capacity capable of Providing Maximum Torque

$$\text{Motor Capacity [kW]} = 1.048 \cdot N \cdot T_{MAX} \cdot 10^{-4} / 1.5$$

N: Maximum Rotations (r/min)

Inverter Capacity Selection

Select an inverter that can be used for the selected motor in the process of "Motor Selection".

Generally, select an inverter which fits the maximum applicable motor capacity of the selected motor.

After selecting an inverter, check if it meets with all of the following conditions. If it does not, select an inverter that has a one class larger capacity and check the feasibility again.

Motor Rated Current ≤ Inverter Rated Output Current
Maximum Time of Continuous Torque Output Time in an Application ≤ 1 minute

- Note:**
1. Where the inverter overload capacity is "120% of Rated Output Current for 1 minute", check it for 0.8 minute.
 2. Where a 0 Hz sensor-less vector control is being used, or where torque must be maintained for 0 (r/min) rotation speed and where 150% of the rated torque is frequently required, use an inverter which is one rank larger than the one selected by the above method.

Outline of Braking Resistor Selection

Importance of Braking Resistor

If the regenerative energy generated in deceleration or descent in an application is too great, the main circuit of an inverter may have an increased voltage and it may be damaged.

Because the inverter usually contains the overvoltage LAD stop function, it is not actually damaged. However, the motor stops detecting an error, making a stable and continuous operation disabled. Therefore, you must discharge the regenerative energy outside of the inverter.

● What is Regenerative Energy?

A load connected to a motor has kinetic energy when rotating, and potential energy when it is located in a high position. When the motor decelerates, or when the load descends, the energy is returned to an inverter. It is known as regeneration, and the energy generated by the phenomenon is known as regenerative energy.

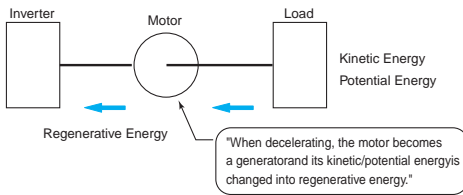

● Preventing Braking Resistance

The following are methods to prevent the connection of braking resistance.

These methods will make the deceleration time increase, so check if it will not cause problems.

- Enable the deceleration stall prevention (enabled in factory settings) (It will automatically increase deceleration time not to cause an overvoltage to stop the motor).
- Set a longer deceleration time. (Cause the regenerative energy to decrease per unit of time.)
- Disable Free-Run. (Prevent the regenerative energy from returning to an inverter.)

Make a Simple Selection for Braking Resistors

It can be a simple selecting method by using the ratio of time in which regenerative energy is produced in a normal operating pattern. Calculate the usage ratio from the following operating pattern.

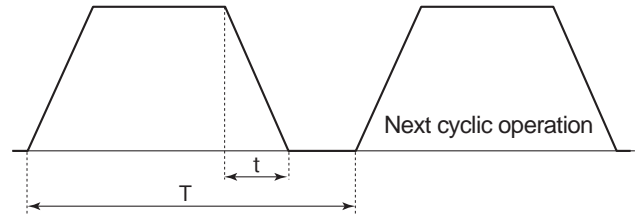

$$\text{Usage Rate} = t/T \times 100 (\% \text{ ED})$$

t : Deceleration Time (Regenerative Time)

T : Single Cycle Operation Time

%ED is the unit used for a usage rate.

The usage rate is used as the ratio of deceleration time (regenerative operation time) to simplify the selection of the braking options.

● For Models without a Built-in Braking Circuit (3G3JX)

Select the regenerative braking unit and the braking resistor. Refer to the regenerative braking unit and braking resistor lists described in the User's manual and catalog, and connect them according to your Inverter.

Make a Simple Selection of Braking Resistor

When the usage ratio for the braking resistor selected on the previous page exceeds 10% ED, or when an extremely large braking torque is required, use the method below to calculate a regenerative energy and make your selection.

● Calculation of Required Braking Resistor

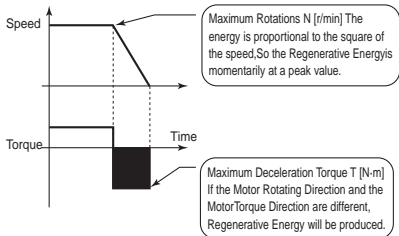

$$\text{Braking Resistance Resistor: } R \leq \frac{V^2}{1.048 \times (T - 0.2 \times T_m) \times N \times 10^{-1}}$$

V: 200V class inverter 385 [V]

400V class inverter 760 [V]

T: Maximum Braking Torque [N-m]

T_m: Motor Rated Torque [N-m]

N: Maximum Rotation Speed [r/min]

Note: Calculate a braking torque using the above "Motor Capacity Selection".

● Calculation of Average Regenerative Energy

Regenerative Energy is produced when the motor rotation direction and the torque direction are opposite.

Use the following formula to calculate a regenerative energy per cycle interval.

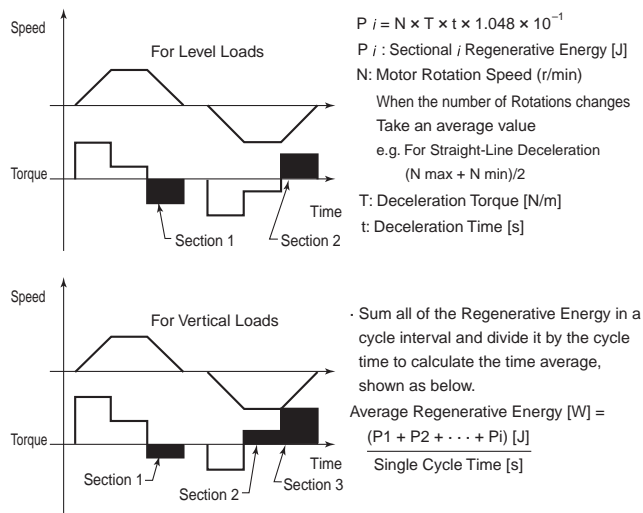

- Note:**
1. Forward rotation direction is forward for the speed, and the torque in the forward rotation direction is forward for the torque.
 2. Calculate a braking torque using the above "Motor Capacity Selection".

● Braking Resistor Selection

Select a Braking Resistor from the required braking resistance and average regenerative energy on the left.

- Required Braking Resistance \geq Resistance of Braking Resistor \geq Minimum Connection Resistance of Inverter or Regenerative Braking Unit
- Average Regenerative Energy \leq Permissible Power for Braking Resistor

- Note:**
1. If a resistance that has a less than the minimum connectable value is connected on an inverter or regenerative braking resistor unit, the internal braking transistor can be damaged. When the required braking resistance is less than the minimum connectable resistance, change the inverter or regenerative energy braking to the one having a larger capacity and a minimum connection resistance less than the required braking resistance.
 2. Two or more regenerative braking units can be operated in parallel. Refer to the following formula to know the braking resistance value in such a case.
 Braking Resistance(Ω) = (Required Braking Resistance as calculated above) \times (No. of Units in use)
 3. Do not use the above formula to select a generative braking resistance value. 150W does not reflect a permissible power capacity, but the maximum rated power per unit of resistance. The actual permissible power varies according to a resistance.

Simple, Compact Inverters JX-Series

Related Manuals

Man.No.	Model	Manual
I558	3G3JX	JX series Compact Simplified Inverters User's Manual
W463	CXONE-AL□□C/D-V□	CX-One FA Integrated Tool Package Setup Manual
W453	CXONE-AL□□C/D-V□ WS02-DRVC01	CX-Drive OPERATION MANUAL

Other Products in the Inverter Series

Choose the Inverter that meets your needs -- From a wide range of simple to advanced models.

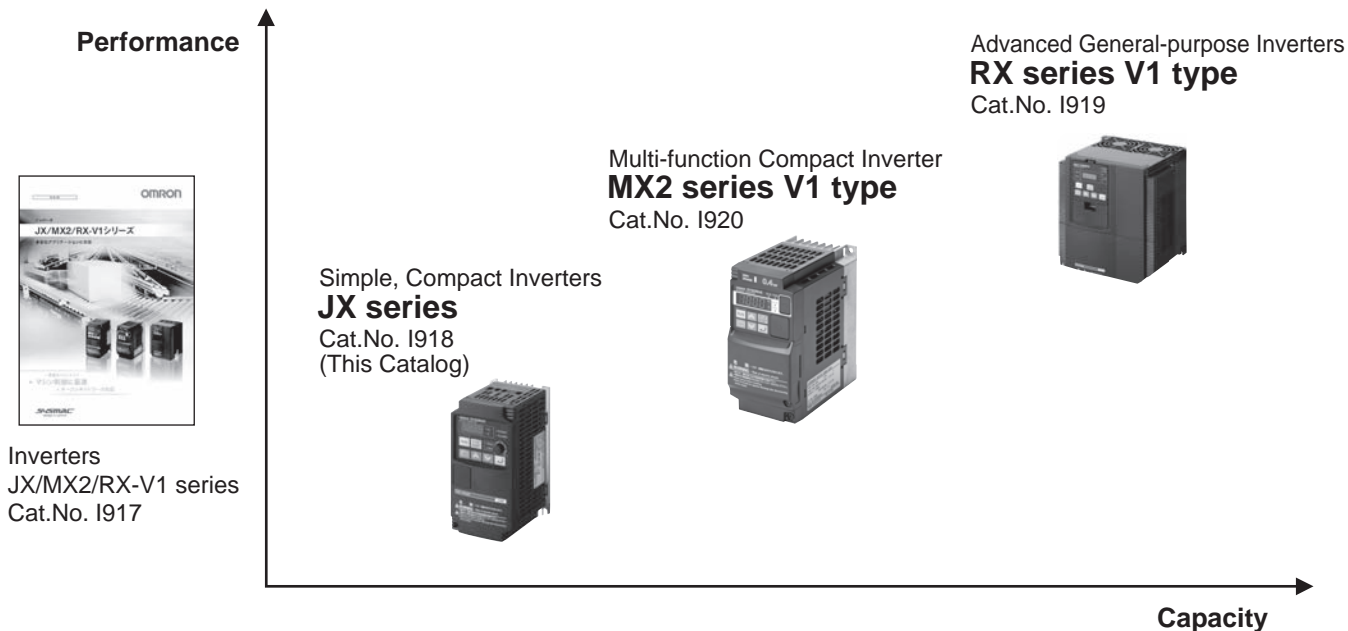

Read and Understand this Catalog

Please read and understand this catalog before purchasing the product. Please consult your OMRON representative if you have any questions or comments.

Warranty and Limitations of Liability

WARRANTY

OMRON's exclusive warranty is that the products are free from defects in materials and workmanship for a period of one year (or other period if specified) from date of sale by OMRON.

OMRON MAKES NO WARRANTY OR REPRESENTATION, EXPRESS OR IMPLIED, REGARDING NON-INFRINGEMENT, MERCHANTABILITY, OR FITNESS FOR PARTICULAR PURPOSE OF THE PRODUCTS. ANY BUYER OR USER ACKNOWLEDGES THAT THE BUYER OR USER ALONE HAS DETERMINED THAT THE PRODUCTS WILL SUITABLY MEET THE REQUIREMENTS OF THEIR INTENDED USE. OMRON DISCLAIMS ALL OTHER WARRANTIES, EXPRESS OR IMPLIED.

LIMITATIONS OF LIABILITY

OMRON SHALL NOT BE RESPONSIBLE FOR SPECIAL, INDIRECT, OR CONSEQUENTIAL DAMAGES, LOSS OF PROFITS, OR COMMERCIAL LOSS IN ANY WAY CONNECTED WITH THE PRODUCTS, WHETHER SUCH CLAIM IS BASED ON CONTRACT, WARRANTY, NEGLIGENCE, OR STRICT LIABILITY.

In no event shall the responsibility of OMRON for any act exceed the individual price of the product on which liability is asserted.

IN NO EVENT SHALL OMRON BE RESPONSIBLE FOR WARRANTY, REPAIR, OR OTHER CLAIMS REGARDING THE PRODUCTS UNLESS OMRON'S ANALYSIS CONFIRMS THAT THE PRODUCTS WERE PROPERLY HANDLED, STORED, INSTALLED, AND MAINTAINED AND NOT SUBJECT TO CONTAMINATION, ABUSE, MISUSE, OR INAPPROPRIATE MODIFICATION OR REPAIR.

Application Considerations

SUITABILITY FOR USE

OMRON shall not be responsible for conformity with any standards, codes, or regulations that apply to the combination of products in the customer's application or use of the products.

Take all necessary steps to determine the suitability of the product for the systems, machines, and equipment with which it will be used.

Know and observe all prohibitions of use applicable to this product.

NEVER USE THE PRODUCTS FOR AN APPLICATION INVOLVING SERIOUS RISK TO LIFE OR PROPERTY WITHOUT ENSURING THAT THE SYSTEM AS A WHOLE HAS BEEN DESIGNED TO ADDRESS THE RISKS, AND THAT THE OMRON PRODUCTS ARE PROPERLY RATED AND INSTALLED FOR THE INTENDED USE WITHIN THE OVERALL EQUIPMENT OR SYSTEM.

PROGRAMMABLE PRODUCTS

OMRON shall not be responsible for the user's programming of a programmable product, or any consequence thereof.

Disclaimers

CHANGE IN SPECIFICATIONS

Product specifications and accessories may be changed at any time based on improvements and other reasons.

It is our practice to change model numbers when published ratings or features are changed, or when significant construction changes are made. However, some specifications of the products may be changed without any notice. When in doubt, special model numbers may be assigned to fix or establish key specifications for your application on your request. Please consult with your OMRON representative at any time to confirm actual specifications of purchased products.

DIMENSIONS AND WEIGHTS

Dimensions and weights are nominal and are not to be used for manufacturing purposes, even when tolerances are shown.

PERFORMANCE DATA

Performance data given in this catalog is provided as a guide for the user in determining suitability and does not constitute a warranty. It may represent the result of OMRON's test conditions, and the users must correlate it to actual application requirements. Actual performance is subject to the OMRON Warranty and Limitations of Liability.

Note: Do not use this document to operate the Unit.

OMRON Corporation Industrial Automation Company

Tokyo, JAPAN

Contact: www.ia.omron.com

Regional Headquarters

OMRON EUROPE B.V.

Wegalaan 67-69-2132 JD Hoofddorp
The Netherlands
Tel: (31)2356-81-300/Fax: (31)2356-81-388

OMRON ELECTRONICS LLC

One Commerce Drive Schaumburg,
IL 60173-5302 U.S.A.
Tel: (1) 847-843-7900/Fax: (1) 847-843-7787

OMRON ASIA PACIFIC PTE. LTD.

No. 438A Alexandra Road # 05-05/08 (Lobby 2),
Alexandra Technopark,
Singapore 119967
Tel: (65) 6835-3011/Fax: (65) 6835-2711

OMRON (CHINA) CO., LTD.

Room 2211, Bank of China Tower,
200 Yin Cheng Zhong Road,
PuDong New Area, Shanghai, 200120, China
Tel: (86) 21-5037-2222/Fax: (86) 21-5037-2200

Authorized Distributor:

© OMRON Corporation 2012 All Rights Reserved.
In the interest of product improvement,
specifications are subject to change without notice.

CSM_8_1_0315

Cat. No. I918-E1-01

0612(0612)