

V1000 to GA500

Industrial AC Microdrive Product Transition Guide

Model: CIMR-VU

240 V Single-Phase Input : 1/8 to 5 HP
240 V Three-Phase Input : 1/8 to 25 HP
480 V Three-Phase Input : 1/2 to 25 HP

Catalog Code: GA50U

240 V Single-Phase Input : 1/6 to 5 HP
240 V Three-Phase Input : 1/6 to 30 HP
480 V Three-Phase Input : 1/2 to 40 HP

This guide lists only comparable models. Refer to the GA500 Selection Guide No. SL.GA500.01 for a list of all available models.

Wiki
LZonline
lalehzaronline.com/wiki

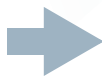

AC Drive Transition Guide

V1000 to GA500

This document is intended to help OEM's, Integrators, and End Users select and replace Yaskawa V1000 series AC drives with Yaskawa GA500 AC drives. Replacement should be conducted by qualified personnel familiar with AC drive installation. Follow local electrical codes during replacement and installation.

- 1 MODEL IDENTIFICATION4**
- 2 REPLACEMENT GA500 DRIVE SELECTION5**
- 3 DIMENSIONS AND ADAPTERS7**
- 4 BRANCH CIRCUIT PROTECTION.9**
- 5 MAIN CIRCUIT AND MOTOR WIRING12**
- 6 CONTROL CIRCUIT WIRING.19**
- 7 TRANSFER OF PARAMETER SETTINGS28**
- 8 CARRIER FREQUENCY - C6-02 [CARRIER FREQUENCY SELECTION]. . . .40**
- 9 WATT LOSS COMPARISON41**
- 10 NETWORK COMMUNICATION AND CONTROL I/O OPTIONS.44**
- 11 OTHER OPTION COMPATIBILITY45**

1 Model Identification

◆ Identify Your Model

The catalog numbers differ slightly between the drive series. Use this number comparison to understand nameplate location and catalog code differences between series when selecting a replacement drive.

V1000 Drive

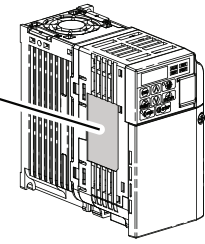
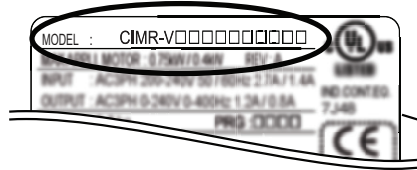

CIMR-V U 2 A 001 F A A

V1000 Drive	
Region Code	
U	Americas
Input Power Supply Voltage	
B	1-phase, 200-240 Vac
2	3-phase, 200-240 Vac
4	3-phase, 380-480 Vac
Customized Specifications	
A	Standard Model
Rated Output Current	
Note: Refer to rated output current specification	

Design Revision Order	
Environmental Specification	
A	Standard
M	Humidity and dust-resistant
S	Vibration resistant
Enclosure Type	
A	IP00/Open-Chassis
B	IP20/Open-Chassis
F	IP20/NEMA Type 1
G	NEMA 4X/IP66
J	IP20/Finless
L	IP00/Finless

GA500 Drive

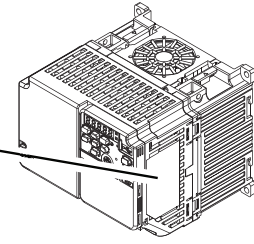
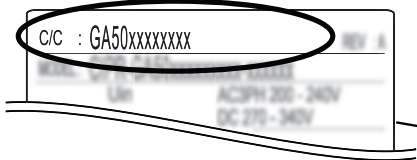

GA50 U 4 004 A B A

GA500 Drive	
Region Code	
U	Americas
Input Power Supply Voltage	
B	1-Phase 240 V Class
2	3-Phase 240 V Class
4	3-Phase 480 V Class
Rated Output Current	
Note: Refer to rated output current specification	

Environmental Specification	
A	Standard
Enclosure Design	
B	IP20/Protected Chassis
EMC Noise Filter	
A	No Internal EMC Filter
E	Internal EMC Filter

2 Replacement GA500 Drive Selection

Table 1 through **Table 3** provide a model to model cross reference. Select the GA500 model that corresponds to your V1000 model.

Increasing the Carrier Frequency parameter C6-02 from the factory default setting may require derating of the drive capacity. *Refer to Carrier Frequency - C6-02 [Carrier Frequency Selection] on page 40* to understand the effect of changing parameter C6-02 on your new replacement drive.

Note: Normal Duty overload tolerance.

- V1000 120% of rated normal duty current for 60 seconds.
- GA500 110% of rated normal duty current for 60 seconds.

Table 1 Single-Phase 240 V Models

V1000 Model CIMR-VU	Rated Output Heavy Duty (HD) Amps	Rated Output Normal Duty (ND) Amps		GA500 Catalog Code GA50U	Rated Output Heavy Duty (HD) Amps	Rated Output Normal Duty (ND) Amps
BA0001	0.8	1.2	↔	B001	0.8	1.2
BA0002	1.6	1.9	↔	B002	1.6	1.9
BA0003	3.0	3.3	↔	B004	3.0	3.5
BA0006	5.0	6.0	↔	B006	5.0	6.0
BA0010	8.0	9.6	↔	B010	8.0	9.6
BA0012	11.0	12.0	↔	B012	11.0	12.2
BA0018	17.5	-	↔	B018	17.6	-

Table 2 Three-Phase 240 V Models

V1000 Model CIMR-VU	Rated Output Heavy Duty (HD) Amps	Rated Output Normal Duty (ND) Amps		GA500 Catalog Code GA50U	Rated Output Heavy Duty (HD) Amps	Rated Output Normal Duty (ND) Amps
2A0001	0.8	1.2	↔	2001	0.8	1.2
2A0002	1.6	1.9	↔	2002	1.6	1.9
2A0004	3.0	3.5	↔	2004	3.0	3.5
2A0006	5.0	6.0	↔	2006	5.0	6.0
2A0010	8.0	9.6	↔	2010	8.0	9.6
2A0012	11.0	12.0	↔	2012	11.0	12.2
2A0020	17.5	19.6	↔	2021	17.6	21.0
2A0030	25.0	30.0	↔	2030	25.0	30.0
2A0040	33.0	40.0	↔	2042	33.0	42.0
2A0056	47.0	56.0	↔	2056	47.0	56.0
2A0069	60.0	69.0	↔	2070	60.0	70.0
-	-	-		2082	75.0	82.0

2 Replacement GA500 Drive Selection

Table 3 Three-Phase 480 V Models

V1000 Model CIMR-VU	Rated Output Heavy Duty (HD) Amps	Rated Output Normal Duty (ND) Amps		GA500 Catalog Code GA50U	Rated Output Heavy Duty (HD) Amps	Rated Output Normal Duty (ND) Amps
4A0001	1.2	1.2	⇔	4001	1.2	1.2
4A0002	1.8	2.1	⇔	4002	1.8	2.1
4A0004	3.4	4.1	⇔	4004	3.4	4.1
4A0005	4.8	5.4	⇔	4005	4.8	5.4
4A0007	5.5	6.9	⇔	4007	5.6	7.1
4A0009	7.2	8.8	⇔	4009	7.3	8.9
4A0011	9.2	11.1	⇔	4012	9.2	11.9
4A0018	14.8	17.5	⇔	4018	14.8	17.5
4A0023	18.0	23.0	⇔	4023	18.0	23.4
4A0031	24.0	31.0	⇔	4031	24.0	31.0
4A0038	31.0	38.0	⇔	4038	31.0	38.0
-	-	-		4044	39.0	44.0
-	-	-		4060	45.0	60.0

3 Dimensions and Adapters

◆ Dimension Comparison and Mounting Kits

The standard model V1000 enclosure is wall-mount UL Type 1. GA500 dimensions for the optional UL Type 1 kit assembled to the GA500 are also shown. Use these tables to understand physical dimensions when required for replacing the V1000 with a new GA500 drive.

Note:

- V1000 and GA500 have the same mounting dimensions. No mounting kit conversion is required.
- Dimensions in this document are approximate. Refer to the Technical Manual or Dimension Diagrams for exact dimensions.

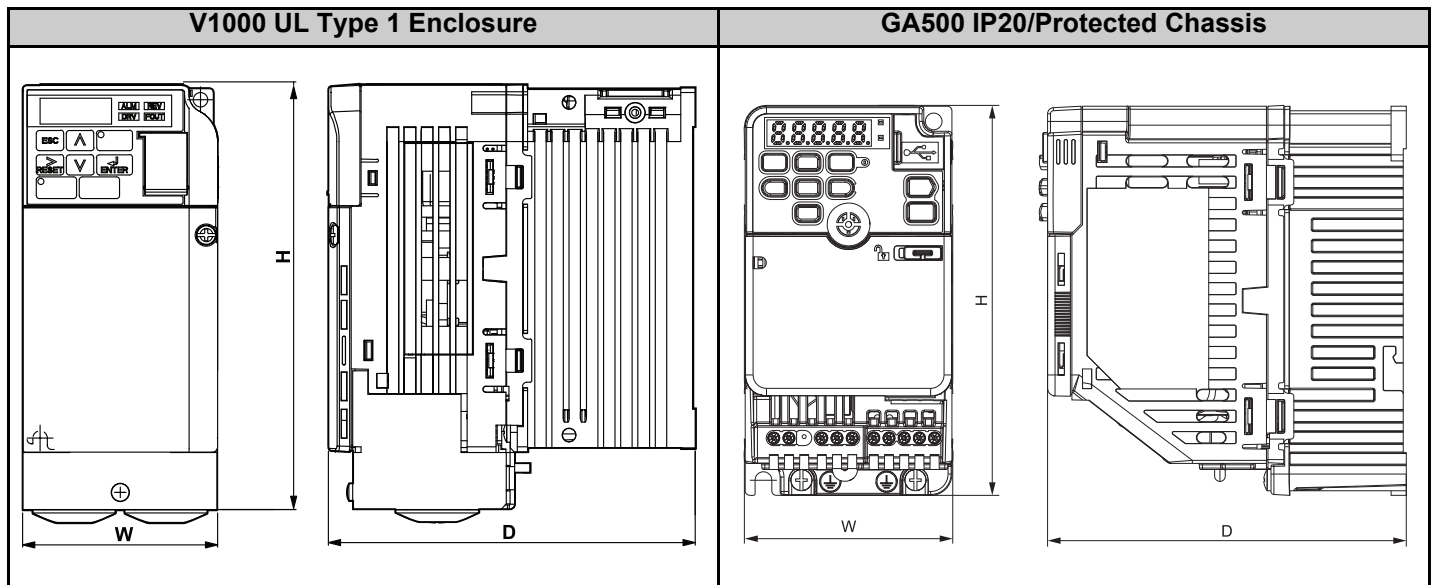

Table 4 Single-Phase, 240 V Models - Exterior Dimensions and Enclosure Kits

V1000 Frame	V1000 Model	GA500 Frame	GA500 Catalog Code GA50U_	GA500 UL Type 1 Enclosure Kit	V1000 UL Type 1 Enclosures	GA500 Protected Chassis Enclosures	GA500 IP20/UL Type 1 Enclosures
	CIMR-VU		GA50U	Catalog Code	H x W x D in	H x W x D in	H x W x D in
1	BA0001	1.1	B001	ZBAA-GA50V1-1	5.89 x 2.68 x 2.99	5.04 x 2.68 x 2.99	5.83 x 2.68 x 2.99
1	BA0002	1.1	B002				
3	BA0003	1.3	B004	ZBAA-GA50V1-2	5.89 x 2.68 x 4.65	5.04 x 2.68 x 4.65	5.83 x 2.68 x 4.65
8	BA0006	2.4	B006	ZBAA-GA50V2-1	5.89 x 4.25 x 5.41	5.04 x 4.25 x 5.41	7.01 x 4.25 x 5.41
10	BA0010	2.5	B010	ZBAA-GA50V2-2	5.89 x 4.25 x 6.06	5.04 x 4.25 x 6.06	7.01 x 4.25 x 6.06
12	BA0012	3.2	B012	ZBAA-GA50V3-1	6.02 x 5.51 x 6.42	5.04 x 5.51 x 6.42	7.01 x 5.51 x 6.42
13	BA0018	4	B018	ZBAA-GA50V4-1	6.02 x 6.69 x 7.09	5.04 x 6.69 x 7.09	7.17 x 6.69 x 7.09

3 Dimensions and Adapters

Table 5 Three-Phase, 240 V Models - Exterior Dimensions and Enclosure Kits

V1000 Frame	V1000 Model	GA500 Frame	GA500 Catalog Code GA50U_	GA500 UL Type 1 Enclosure Kit	V1000 UL Type 1 Enclosures	GA500 Protected Chassis Enclosures	GA500 IP20/UL Type 1 Enclosures
	CIMR-VU		GA50U	Catalog Code	H x W x D in	H x W x D in	H x W x D in
1	2A0001	1.1	2001	ZBAA-GA50V1-1	5.89 x 2.68 x 2.99	5.04 x 2.68 x 2.99	5.83 x 2.68 x 2.99
1	2A0002	1.1	2002		5.89 x 2.68 x 4.25	5.04 x 2.68 x 4.25	5.83 x 2.68 x 4.25
2	2A0004	1.2	2004		5.89 x 2.68 x 5.04	5.04 x 2.68 x 5.04	5.83 x 2.68 x 5.04
4	2A0006	1.4	2006				
7	2A0010	2.3	2010	ZBAA-GA50V2-3	5.89 x 4.25 x 5.08	5.04 x 4.25 x 5.08	7.01 x 4.25 x 5.08
8	2A0012	2.4	2012	ZBAA-GA50V2-1	5.89 x 4.25 x 5.41	5.04 x 4.25 x 5.41	7.01 x 4.25 x 5.41
11	2A0020	3.1	2021	ZBAA-GA50V3-2	6.02 x 5.51 x 5.63	5.04 x 5.51 x 5.63	7.01 x 5.51 x 5.63
14	2A0030	5	2030	ZBAA-GA50V5-1	10 x 5.51 x 5.51	10.24 x 5.51 x 5.51	11.73 x 5.51 x 5.51
14	2A0040	5	2042				
16	2A0056	6	2056	ZBAA-GA50V6-1	11.42 x 7.09 x 6.42	11.81 x 7.09 x 5.63	13.39 x 7.09 x 5.63
17	2A0069	7	2070	ZBAA-GA50V7-1	14.09 x 8.66 x 7.36	13.78 x 8.66 x 7.36	15.87 x 8.66 x 7.36
-	-	7	2082		-	13.78 x 8.66 x 7.36	15.87 x 8.66 x 7.36

Table 6 Three-Phase, 480 V Models - Exterior Dimensions and Enclosure Kits

V1000 Frame	V1000 Model	GA500 Frame	GA500 Catalog Code GA50U_	GA500 UL Type 1 Enclosure Kit	V1000 UL Type 1 Enclosures	GA500 Protected Chassis Enclosures	GA500 IP20/UL Type 1 Enclosures
	CIMR-VU		GA50U	Catalog Code	H x W x D in	H x W x D in	H x W x D in
5	4A0001	2.1	4001	ZBAA-GA50V2-4	5.89 x 4.25 x 3.19	5.04 x 4.25 x 3.19	5.87 x 4.25 x 3.19
6	4A0002	2.2	4002	ZBAA-GA50V2-5	5.89 x 4.25 x 3.9	5.04 x 4.25 x 3.9	5.87 x 4.25 x 3.9
8	4A0004	2.4	4004	ZBAA-GA50V2-2	5.89 x 4.25 x 5.41	5.04 x 4.25 x 5.41	5.87 x 4.25 x 5.41
9	4A0005	2.5	4005		5.89 x 4.25 x 6.06	5.04 x 4.25 x 6.06	7.01 x 4.25 x 6.06
9	4A0007	2.5	4007				
9	4A0009	2.5	4009	ZBAA-GA50V3-2	5.89 x 4.25 x 6.06	5.04 x 4.25 x 6.06	7.01 x 4.25 x 6.06
11	4A0011	3.1	4012		6.02 x 5.51 x 5.63	5.04 x 5.51 x 5.63	7.01 x 5.51 x 5.63
14	4A0018	5	4018	ZBAA-GA50V5-1	10 x 5.51 x 5.51	10.24 x 5.51 x 5.51	11.73 x 5.51 x 5.51
14	4A0023	5	4023				
15	4A0031	6	4031	ZBAA-GA50V6-1	11.42 x 7.09 x 5.63	11.81 x 7.09 x 5.63	13.39 x 7.09 x 5.63
16	4A0038	6	4038		11.42 x 7.09 x 6.42	11.81 x 7.09 x 5.63	13.39 x 7.09 x 5.63
-	-	8	4044	ZBAA-GA50V8-1	-	13.78 x 7.48 x 8.03	15.87 x 7.48 x 8.03
-	-	8	4060		-		

4 Branch Circuit Protection

Use this section to understand if the existing V1000 branch circuit protection is suitable for the replacement GA500 drive.

◆ V1000 Branch Circuit Protection

Table 7 V1000 Branch Circuit Protection

Drive Model CIMR-VU	Fuse Type: Class T, Non-Time Delay (Manufacturer: Ferraz) Rating: 600 Vac, 200 kAIR		Fuse Type: Semiconductor Fuse, Fast Acting (Manufacturer: Busmann) Rating: 500 Vac, 200 kAIR	
	Fuse	Amp	Fuse	Amp
Single-Phase 240 V				
BA0001	A6T6	6	FWH-25A14F	25
BA0002	A6T10	10	FWH-25A14F	25
BA0003	A6T20	20	FWH-60B	60
BA0006	A6T40	40	FWH-80B	80
BA0010	A6T40	40	FWH-100B	100
BA0012	A6T50	50	FWH-125B	125
BA0018	A6T80	80	FWH-175B	175
Three-Phase 240 V				
2A0001	A6T3	3	FWH-25A14F	25
2A0002	A6T6	6	FWH-25A14F	25
2A0004	A6T15	15	FWH-25A14F	25
2A0006	A6T20	20	FWH-25A14F	25
2A0010	A6T25	25	FWH-70B	70
2A0012	A6T25	25	FWH-70B	70
2A0020	A6T40	40	FWH-90B	90
2A0030	–	–	FWH-100B	100
2A0040	–	–	FWH-200B	200
2A0056	–	–	FWH-200B	200
2A0069	–	–	FWH-200B	200
Three-Phase 480 V				
4A0001	A6T3	3	FWH-40B	40
4A0002	A6T6	6	FWH-40B	40
4A0004	A6T15	15	FWH-50B	50
4A0005	A6T20	20	FWH-70B	70
4A0007	A6T25	25	FWH-70B	70
4A0009	A6T25	25	FWH-90B	90
4A0011	A6T30	30	FWH-90B	90
4A0018	–	–	FWH-80B	80
4A0023	–	–	FWH-100B	100
4A0031	–	–	FWH-125B	125
4A0038	–	–	FWH-200B	200

4 Branch Circuit Protection

◆ GA500 Branch Circuit Protection

Use branch circuit protection to protect against short circuits and to maintain compliance with UL61800-5-1. Yaskawa recommends connecting semiconductor protection fuses on the input side for branch circuit protection.

- 240 V model fuse selection:

Use the fuses specified in this document or in the drive product instructions to prepare the drive for use on a circuit that supplies not more than 31,000 Amps RMS and not more than 240 Vac when there is a short circuit in the power supply.

- 480 V model fuse selection:

Use the fuses specified in this document or in the drive product instructions to prepare the drive for use on a circuit that supplies not more than 31,000 Amps RMS and not more than 480 Vac when there is a short circuit in the power supply.

The built-in short circuit protection of the drive does not provide branch circuit protection. The user must provide branch circuit protection as specified by the National Electric Code (NEC), the Canadian Electric Code, Part I (CEC), and local codes.

Table 8 GA500 Branch Circuit Protection

GA500 Catalog Code GA50U_	Fuse Type: Class J, T, and CC Time-delay Rated Current (A)	Fuse Type: Semiconductor Fuse, Fast Acting (Manufacturer: EATON/Bussmann)	
		Model	Amp
Single-Phase 240 V			
B001	2	FWH-25A14F	25
B002	3.5	FWH-25A14F	25
B004	9	FWH-60B	60
B006	15	FWH-80B	80
B010	20	FWH-100B	100
B012	30	FWH-125B	125
B018	40	FWH-150B	150
Three-Phase 240 V			
2001	3	FWH-25A14F	25
2002	3.5	FWH-25A14F	25
2004	6	FWH-25A14F	25
2006	10	FWH-25A14F	25
2010	15	FWH-70B	70
2012	20	FWH-70B	70
2021	35	FWH-90B	90
2030	50	FWH-100B	100
2042	70	FWH-150B	150
2056	90	FWH-200B	200
2070	110	FWH-200B	200
2082	125	FWH-225A	225
Three-Phase 480 V			
4001	3	FWH-40B	40
4002	3.5	FWH-40B	40
4004	7	FWH-50B	50
4005	9	FWH-70B	70
4007	12	FWH-70B	70
4009	15	FWH-90B	90
4012	20	FWH-90B	90
4018	30	FWH-80B	80
4023	40	FWH-100B	100

4 Branch Circuit Protection

GA500 Catalog Code GA50U_	Fuse Type: Class J, T, and CC Time-delay Rated Current (A)	Fuse Type: Semiconductor Fuse, Fast Acting (Manufacturer: EATON/Bussmann)	
		Model	Amp
4031	50	FWH-125B	125
4038	60	FWH-175B	175
4044	70	FWH-200B	200
4060	100	FWH-200B	200

5 Main Circuit and Motor Wiring

Use this section to convert the V1000 main circuit wiring for installation to the GA500.

Key wiring differences between the V1000 and GA500 are:

- V1000 uses crimp terminals/ring lugs and GA500 accepts bare wire (except for ground terminal).
- Terminal sizes, shapes or physical location may differ slightly between V1000 and GA500.

Information in this section:

- **Main Circuit Connection Diagram on page 12**
- **Main Circuit Wiring Procedure on page 12**
- **Wire Termination Differences V1000 to GA500 on page 13**
- **Main Circuit and Motor Terminal Layout Comparison on page 13**
- **Main Circuit and Motor Wire Gauge and Tightening Torque on page 15**

◆ Main Circuit Connection Diagram

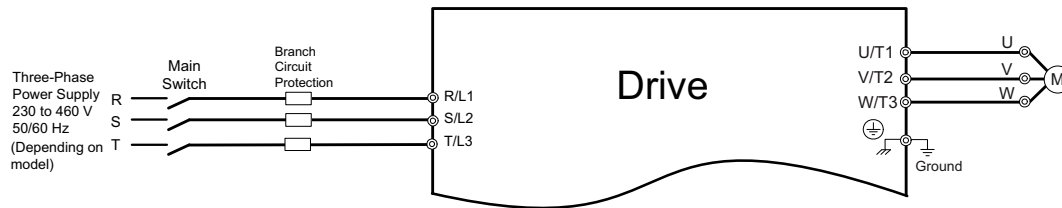

Figure 1 Main Circuit Connection Diagram (Typical)

◆ Main Circuit Wiring Procedure

Follow the GA500 Installation & Primary Operation Manual (No. TOEPC71061752) for all wiring procedures.

NOTICE:

- A screwdriver or hexagonal tool must be used when wiring the terminal.
- When stranded wire is used, wire it so that no loose wire strands protrude out of the connection. Do not excessively twist stranded wire.
- Do not solder wire ends.
- Do not use bent or crushed wire. Cut off any rough ends of the wire before installation.

1. Label the V1000 terminal wires before removing.
2. Remove crimp terminals if needed, and prepare wire ends.
3. Expose the required length of bare wire by stripping the insulation to the strip length in **Table 9**.
4. Wire the terminals. The wire will correctly fit the terminal block when the insulation is stripped to expose the correct wire length.
5. Tighten screws according to the tightening torque listed in the GA500 Installation and Primary Operation Manual No. TOEPC71061752.
6. Dress and arrange wires so that excessive wire tension is not applied to the terminal block.
7. After connecting the wires, gently pull on the wires to check that they do not pull out.
8. Regularly tighten any loose terminal block screws to their specified tightening torque.

◆ Wire Termination Differences V1000 to GA500

If crimp terminal ends/ring lugs are present on the V1000, they must be removed and the wire stripped to bare wire for installation to the GA500. Refer to the GA500 Installation & Primary Operation Manual No. TOEPC71061752, for more information on wire termination.

■ Main Circuit and Motor Terminal Layout Comparison

Terminal location and appearance differs slightly between V1000 and GA500. Use this section to understand differences to prepare for wiring the GA500.

- Refer to **Figure 2** for V1000 Main Circuit and Motor Circuit Terminal Layout by Model
- Refer to **Figure 3** for GA500 Main Circuit and Motor Circuit Terminal Layout by Model

Models: CIMR-V□BA0001, 0002, 0003
CIMR-V□2A0001, 0002, 0004, 0006

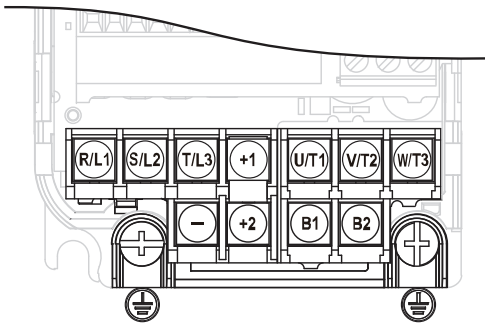

Models: CIMR-V□BA0006, 0010, 0012
CIMR-V□2A0010, 0012, 0020
CIMR-V□4A0001, 0002, 0004, 0005
0007, 0009, 0011

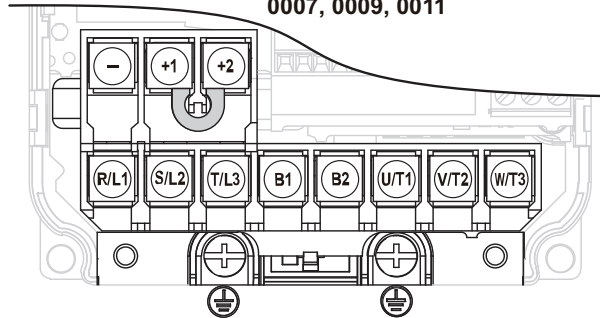

Models: CIMR-V□2A0030, 0040
CIMR-V□4A0018, 0023

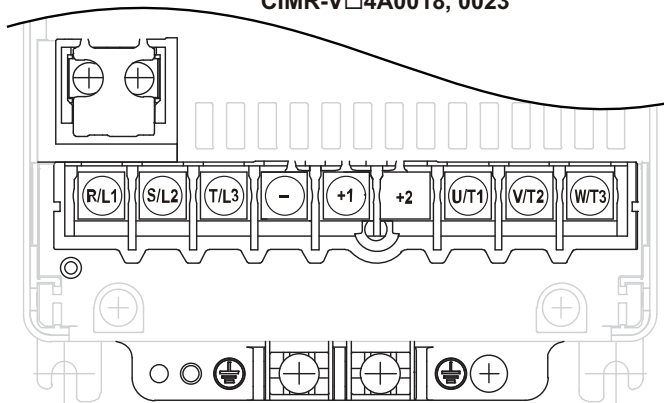

Model: CIMR-V□2A0069

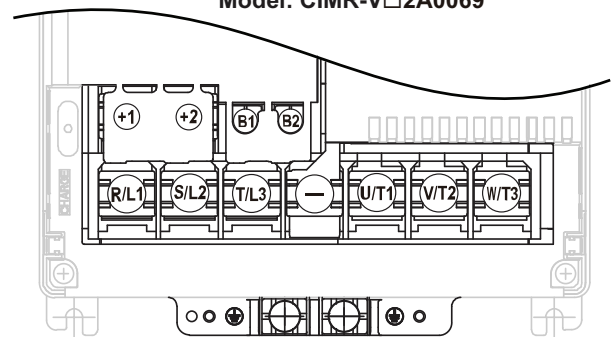

Model: CIMR-V□BA0018

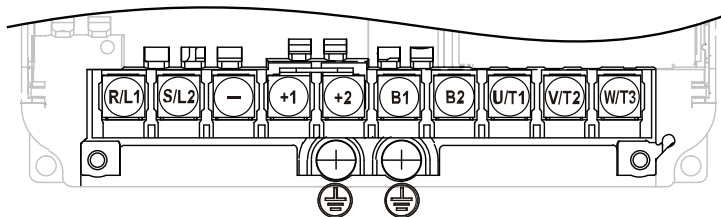

Models: CIMR-V□2A0056
CIMR-V□4A0031, 0038

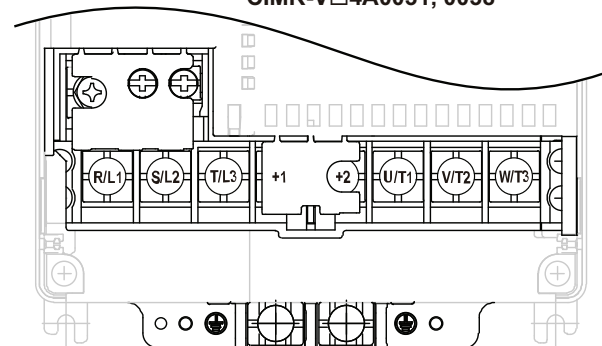
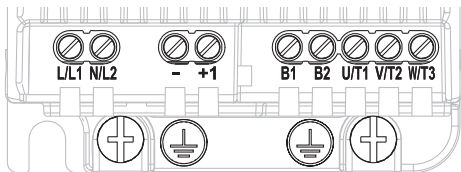

Figure 2 V1000 Main Circuit and Motor Circuit Terminal Layout by Model

5 Main Circuit and Motor Wiring

Models: GA50UB001□, B002, B004



Models: GA50UB006□, B010

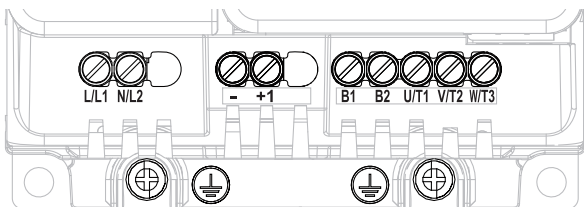

Model: GA50UB012□

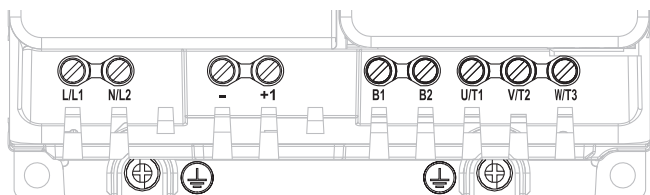

Model: GA50UB018□

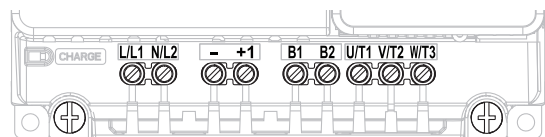

Models: GA50U2056□, 4031, 4038

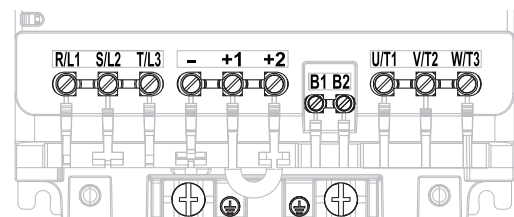

Models: GA50U4044□, 4060

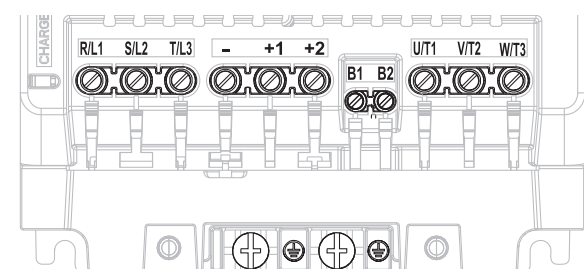

Models: GA50U2001□, 2002, 2004, 2006

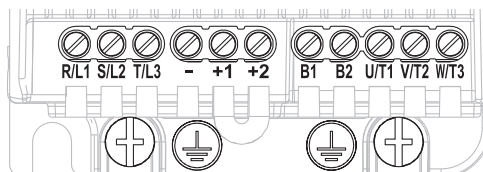

Models: GA50U2012□, 4001, 4002, 4004, 4005, 4007, 4009

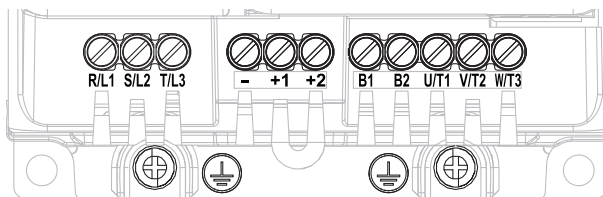

Model: GA50U4012□

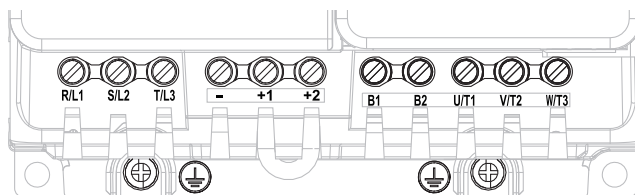

Models: GA50U2030□, 2042, 4018, 4023

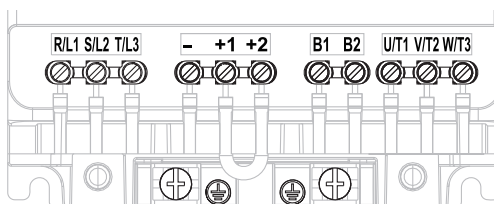

Models: GA50U2070□, 2082

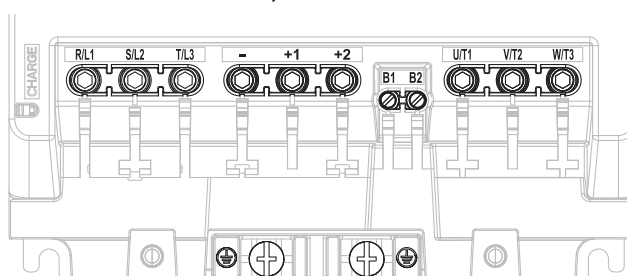

Figure 3 GA500 Main Circuit and Motor Circuit Terminal Layout by Model

■ Main Circuit and Motor Wire Gauge and Tightening Torque

Table 9 lists wire gauge for the drive main circuit terminals. Verify the existing V1000 wire size is within the Wire Range and Recommended Gauge for the GA500.

■ GA500 Main Circuit Wiring Precautions

Wire the main circuit terminal block correctly as specified by the GA500 Installation and Primary Operation Manual No. TOEPC71061752. Comply with local standards for correct wire gauge in the region where you will use the drive.

GA500 Wire Selection and Termination

Use UL Listed vinyl-coated insulated copper wire rated 600 V minimum. Wire gauge must be calculated using 75 °C ratings, higher temperature rated wire may be utilized without a wire gauge reduction.

The recommended wire gauge are based on drive continuous current ratings with 75 °C (167 °F) 600 V class 2 heat-resistant indoor PVC wire. Assume these conditions:

- Ambient temperature: 40 °C (104 °F) maximum
- Wiring distance: 100 m (3281 ft) maximum
- Normal Duty rated current value

GA500 Peripheral Device Wiring

Refer to the instruction manual for each device for recommended wire gauge to connect peripheral devices or options to terminals +1, +2, -, B1, and B2. Contact Yaskawa or your nearest sales representative if the recommended wire gauge for the peripheral devices or options are out of the range of the applicable gauge for the drive.

GA500 Grounding

WARNING! Electrical Shock Hazard

Make sure that the protective ground wire complies with technical standards and local safety regulations. The EN 61800-5-1:2007 standard specifies that you must wire the power supply to automatically de-energize when the protective ground wire disconnects. If you turn on the internal EMC filter, the leakage current of the drive will be more than 3.5 mA. Use these closed-loop crimp terminals or equivalent to connect a protective ground wire that has a minimum cross-sectional area of 10 mm² (copper wire).

- 8-4NS from JST Mfg. Co., Ltd.
- R8-4S from NICHIFU Co., Ltd.
- P10-8R from PANDUIT Corp.

Table 9 Main Circuit and Motor Wire Gauge by Drive Model

V1000				GA500				
Drive Model CIMR-VU_	Terminal	Recom- mended Gauge AWG	Wire Range AWG	Catalog Code GA50U_	Terminal	Recom- mended Gauge AWG	Wire Range AWG	Wire Stripping Length mm
Single-Phase 240 V Models								
BA0001 BA0002 BA0003	R/L1, S/L2, T/L3	14	18 to 14	B001 B002 B004	L/L1, N/L2	14	14	6.5
	U/T1, V/T2, W/T3	14	18 to 14		U/T1, V/T2, W/T3	14	14	6.5
	-, +1, +2	-	18 to 14		-, +1	14	14	6.5
	B1, B2	-	18 to 14		B1, B2	14	14	6.5
	Ground	14	18 to 14		Ground	14	14	-
BA0006	R/L1, S/L2, T/L3	12	14 to 10	B006	L/L1, N/L2	12	14 to 10	8
	U/T1, V/T2, W/T3	14	14 to 10		U/T1, V/T2, W/T3	14	14 to 12	8
	-, +1, +2	-	14 to 10		-, +1	12	14 to 10	8
	B1, B2	-	14 to 10		B1, B2	14	14 to 12	8
	Ground	10	14 to 10		Ground	10	14 to 10	-

5 Main Circuit and Motor Wiring

V1000				GA500				
Drive Model CIMR-VU_	Terminal	Recommended Gauge AWG	Wire Range AWG	Catalog Code GA50U_	Terminal	Recommended Gauge AWG	Wire Range AWG	Wire Stripping Length mm
BA0010	R/L1, S/L2, T/L3	10	14 to 10	B010	L/L1, N/L2	10	12 to 10	8
	U/T1, V/T2, W/T3	14	14 to 10		U/T1, V/T2, W/T3	14	14 to 12	8
	-, +1, +2	-	14 to 10		-, +1	10	12 to 10	8
	B1, B2	-	14 to 10		B1, B2	14	14 to 12	8
	Ground	10	14 to 10		Ground	10	14 to 10	-
BA0012	R/L1, S/L2, T/L3	10	14 to 10	B012	L/L1, N/L2	8	14 to 8	10
	U/T1, V/T2, W/T3	14	14 to 10		U/T1, V/T2, W/T3	12	14 to 10	10
	-, +1, +2	-	14 to 10		-, +1	8	14 to 8	10
	B1, B2	-	14 to 10		B1, B2	14	14 to 12	10
	Ground	10	14 to 10		Ground	10	14 to 10	-
BA0018	R/L1, S/L2, T/L3	8	12 to 8	B018	L/L1, N/L2	8	12 to 6	10
	U/T1, V/T2, W/T3	10	12 to 8		U/T1, V/T2, W/T3	10	14 to 8	10
	-, +1, +2	-	12 to 8		-, +1	8	12 to 6	10
	B1, B2	-	12 to 8		B1, B2	14	14 to 12	10
	Ground	8	12 to 8		Ground	8	12 to 8	-
Three-Phase 240 V Models								
2A0001 2A0002 2A0004 2A0006	R/L1, S/L2, T/L3	14	18 to 14	2001 2002 2004 2006	R/L1, S/L2, T/L3	14	14	6.5
	U/T1, V/T2, W/T3	14	18 to 14		U/T1, V/T2, W/T3	14	14	6.5
	-, +1, +2	-	18 to 14		-, +1, +2	14	14	6.5
	B1, B2	-	18 to 14		B1, B2	14	14	6.5
	Ground	14	18 to 14		Ground	14	14	-
2A0010	R/L1, S/L2, T/L3	12	14 to 10	2010	R/L1, S/L2, T/L3	14	14 to 12	8
	U/T1, V/T2, W/T3	14	14 to 10		U/T1, V/T2, W/T3	14	14 to 12	8
	-, +1, +2	-	14 to 10		-, +1, +2	12	14 to 10	8
	B1, B2	-	14 to 10		B1, B2	14	14 to 12	8
	Ground	10	14 to 10		Ground	10	14 to 10	-
2A0012	R/L1, S/L2, T/L3	12	14 to 10	2012	R/L1, S/L2, T/L3	12	14 to 10	8
	U/T1, V/T2, W/T3	14	14 to 10		U/T1, V/T2, W/T3	12	14 to 10	8
	-, +1, +2	-	14 to 10		-, +1, +2	10	12 to 10	8
	B1, B2	-	14 to 10		B1, B2	14	14 to 12	8
	Ground	10	14 to 10		Ground	10	14 to 10	-
2A0020	R/L1, S/L2, T/L3	10	14 to 10	2021	R/L1, S/L2, T/L3	8	14 to 8	10
	U/T1, V/T2, W/T3	10	14 to 10		U/T1, V/T2, W/T3	10	14 to 8	10
	-, +1, +2	-	14 to 10		-, +1, +2	8	14 to 8	10
	B1, B2	-	14 to 10		B1, B2	14	14 to 10	10
	Ground	10	14 to 10		Ground	8	14 to 8	-
2A0030	R/L1, S/L2, T/L3	8	10 to 6	2030	R/L1, S/L2, T/L3	8	12 to 6	10
	U/T1, V/T2, W/T3	8	10 to 6		U/T1, V/T2, W/T3	8	12 to 6	10
	-, +1, +2	-	10 to 6		-, +1, +2	6	12 to 6	10
	B1, B2	-	14 to 10		B1, B2	12	12 to 8	10
	Ground	8	10 to 6		Ground	8	10 to 6	-
2A0040	R/L1, S/L2, T/L3	6	10 to 6	2042	R/L1, S/L2, T/L3	6	12 to 6	10
	U/T1, V/T2, W/T3	8	10 to 6		U/T1, V/T2, W/T3	6	12 to 6	10
	-, +1, +2	-	10 to 6		-, +1, +2	4	10 to 2	18
	B1, B2	-	14 to 10		B1, B2	10	14 to 6	10
	Ground	6	10 to 6		Ground	6	10 to 6	-

5 Main Circuit and Motor Wiring

V1000				GA500				
Drive Model CIMR-VU_	Terminal	Recom- mended Gauge AWG	Wire Range AWG	Catalog Code GA50U_	Terminal	Recom- mended Gauge AWG	Wire Range AWG	Wire Stripping Length mm
2A0056	R/L1, S/L2, T/L3	4	6 to 4	2056	R/L1, S/L2, T/L3	4	10 to 2	18
	U/T1, V/T2, W/T3	4	6 to 4		U/T1, V/T2, W/T3	4	10 to 2	18
	-, +1, +2	-	6 to 4		-, +1, +2	2	8 to 2	18
	B1, B2	-	10 to 6		B1, B2	8	12 to 6	10
	Ground	6	8 to 4		Ground	6	8 to 4	-
2A0069	R/L1, S/L2, T/L3	3	8 to 2	2070	R/L1, S/L2, T/L3	2	6 to 1	20
	U/T1, V/T2, W/T3	3	8 to 2		U/T1, V/T2, W/T3	2	8 to 1	20
	-, +1, +2	-	8 to 2		-, +1, +2	1	6 to 1/0	20
	B1, B2	-	8 to 6		B1, B2	8	12 to 6	10
	Ground	6	6 to 4		Ground	4	6 to 4	-
-				2082	R/L1, S/L2, T/L3	1	6 to 1/0	20
					U/T1, V/T2, W/T3	2	6 to 1	20
					-, +1, +2	2/0	2 to 2/0	20
					B1, B2	6	10 to 6	10
					Ground	4	6 to 4	-
Three-Phase 480 V Models								
4A0001 4A0002 4A0004	R/L1, S/L2, T/L3	14	14 to 10	4001 4002	R/L1, S/L2, T/L3	14	14 to 12	8
	U/T1, V/T2, W/T3	14	14 to 10		U/T1, V/T2, W/T3	14	14 to 12	8
	-, +1, +2	-	14 to 10		-, +1, +2	14	14 to 12	8
	B1, B2	-	14 to 10		B1, B2	14	14 to 12	8
	Ground	14	14 to 10		Ground	14	14 to 10	-
				4004	R/L1, S/L2, T/L3	14	14 to 12	8
					U/T1, V/T2, W/T3	14	14 to 12	8
					-, +1, +2	14	14 to 12	8
					B1, B2	14	14 to 12	8
					Ground	10	14 to 10	-
4A0005 4A0007 4A0009	R/L1, S/L2, T/L3	14	14 to 10	4005 4007 4009	R/L1, S/L2, T/L3	14	14 to 12	8
	U/T1, V/T2, W/T3	14	14 to 10		U/T1, V/T2, W/T3	14	14 to 12	8
	-, +1, +2	-	14 to 10		-, +1, +2	14	14 to 12	8
	B1, B2	-	14 to 10		B1, B2	14	14 to 12	8
	Ground	10	14 to 10		Ground	10	14 to 10	-
4A0011	R/L1, S/L2, T/L3	12	14 to 10	4012	R/L1, S/L2, T/L3	12	14 to 10	10
	U/T1, V/T2, W/T3	14	14 to 10		U/T1, V/T2, W/T3	14	14 to 12	10
	-, +1, +2	-	14 to 10		-, +1, +2	10	12 to 8	10
	B1, B2	-	14 to 10		B1, B2	14	14 to 12	10
	Ground	10	14 to 10		Ground	10	14 to 10	-
4A0018	R/L1, S/L2, T/L3	10	14 to 6	4018	R/L1, S/L2, T/L3	10	12 to 8	10
	U/T1, V/T2, W/T3	10	14 to 6		U/T1, V/T2, W/T3	10	12 to 8	10
	-, +1, +2	-	14 to 6		-, +1, +2	10	14 to 8	10
	B1, B2	-	14 to 10		B1, B2	14	14 to 12	10
	Ground	8	14 to 6		Ground	10	14 to 6	-
4A0023	R/L1, S/L2, T/L3	10	10 to 6	4023	R/L1, S/L2, T/L3	8	14 to 6	10
	U/T1, V/T2, W/T3	10	10 to 6		U/T1, V/T2, W/T3	10	14 to 8	10
	-, +1, +2	-	10 to 6		-, +1, +2	8	12 to 6	10
	B1, B2	-	14 to 10		B1, B2	12	14 to 10	10
	Ground	8	10 to 6		Ground	10	10 to 6	-

5 Main Circuit and Motor Wiring

V1000				GA500				
Drive Model CIMR-VU_	Terminal	Recom- mended Gauge AWG	Wire Range AWG	Catalog Code GA50U_	Terminal	Recom- mended Gauge AWG	Wire Range AWG	Wire Stripping Length mm
4A0031	R/L1, S/L2, T/L3	8	10 to 6	4031	R/L1, S/L2, T/L3	8	12 to 6	10
	U/T1, V/T2, W/T3	8	10 to 6		U/T1, V/T2, W/T3	8	12 to 6	10
	-, +1, +2	-	10 to 6		-, +1, +2	6	12 to 4	18
	B1, B2	-	14 to 10		B1, B2	10	12 to 8	10
	Ground	6	10 to 6		Ground	8	10 to 6	-
4A0038	R/L1, S/L2, T/L3	6	10 to 6	4038	R/L1, S/L2, T/L3	6	12 to 6	10
	U/T1, V/T2, W/T3	8	10 to 6		U/T1, V/T2, W/T3	8	12 to 6	10
	-, +1, +2	-	10 to 6		-, +1, +2	4	10 to 2	18
	B1, B2	-	10 to 8		B1, B2	10	14 to 6	10
	Ground	6	10 to 6		Ground	6	10 to 6	-
-	-	-	-	4044	R/L1, S/L2, T/L3	4	10 to 2	18
					U/T1, V/T2, W/T3	6	12 to 4	18
					-, +1, +2	2	8 to 2	18
					B1, B2	8	12 to 6	10
					Ground	6	10 to 6	-
-	-	-	-	4060	R/L1, S/L2, T/L3	2	8 to 2	18
					U/T1, V/T2, W/T3	4	10 to 2	18
					-, +1, +2	2	6 to 2	18
					B1, B2	8	12 to 6	10
					Ground	6	10 to 6	-

6 Control Circuit Wiring

Use this section to understand differences between the V1000 and GA500 control circuit wiring to transfer control circuit wiring to the GA500. Refer to the GA500 Installation & Primary Operation Manual or Technical Reference for more details and precautions when wiring the GA500 control circuit terminals.

◆ Control Circuit Terminal Layout

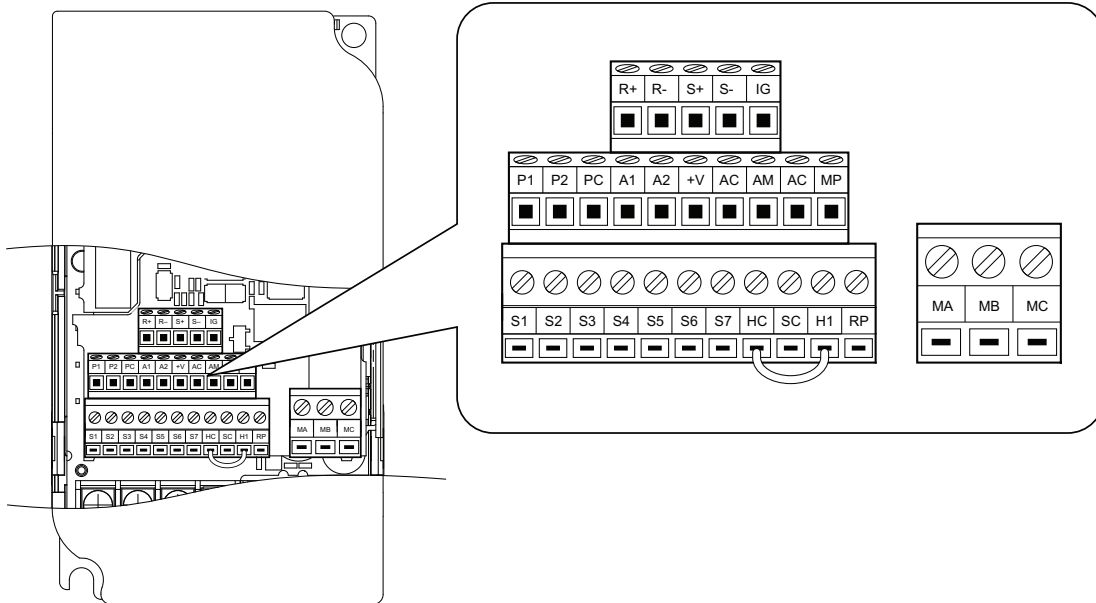

Figure 4 V1000 Control Circuit Terminals

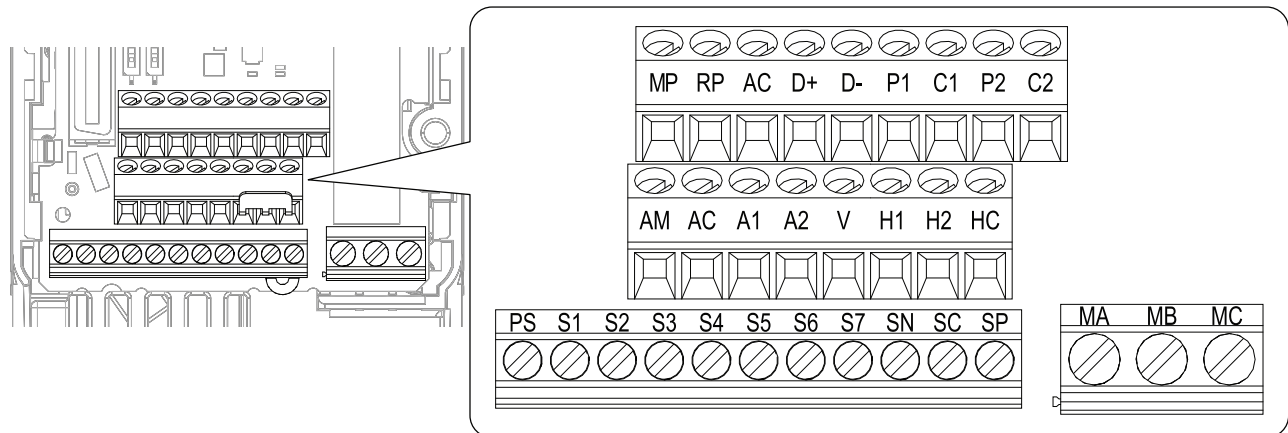

Figure 5 GA500 Control Circuit Terminals

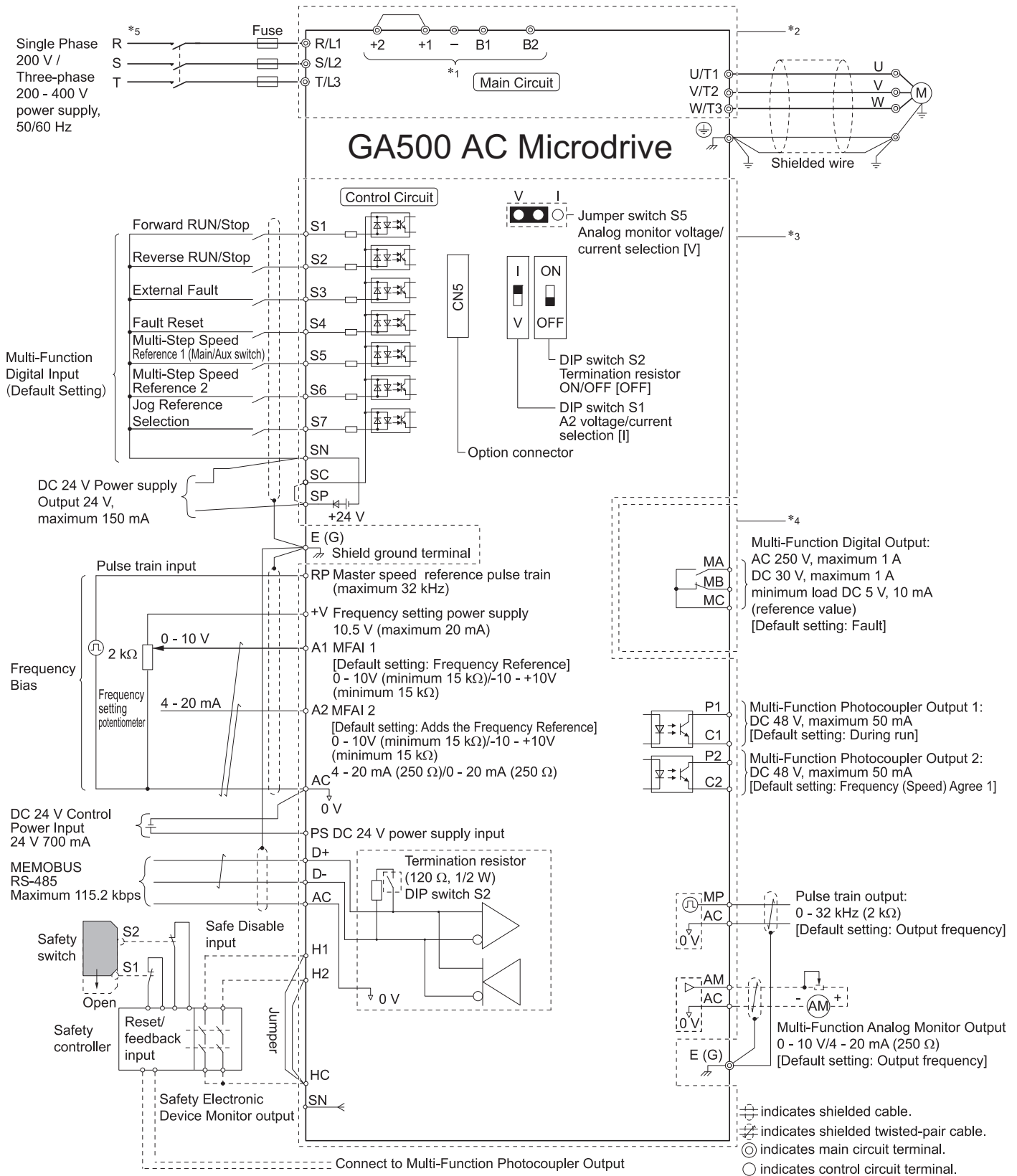

Figure 7 GA500 Connection Diagram

6 Control Circuit Wiring

◆ Control Circuit I/O Cross Reference

Refer to the GA500 Installation & Primary Operation Manual or Technical Reference for more details and precautions when wiring the GA500 control circuit terminals.

Table 10 Control Circuit I/O Cross Reference

Control Circuit Terminals		Name	Signal Level	
V1000	GA500		V1000	GA500
S1	S1	Multi-function digital input selection 1 (ON: Forward run, OFF: Stop)	Photocoupler 24 Vdc, 8 mA	Photocoupler 24 Vdc, 6 mA
S2	S2	Multi-function digital input selection 2 (ON: Reverse run OFF: Stop)		
S3	S3	Multi-function digital input selection 3 (External fault (N.O.))		
S4	S4	Multi-function digital input selection 4 (Fault reset)		
S5	S5	Multi-function digital input selection 5 (Multi-step speed reference 1)		
S6	S6	Multi-function digital input selection 6 (Multi-step speed reference 2)		
S7	S7	Multi-function digital input selection 7 (Jog command)		
-	SN	Multi-function digital input power supply 0 V	-	Multi-function digital input power supply, 24 V (Maximum 150 mA) Notice: Do not jumper or short terminals SP and SN. Failure to comply will damage the drive.
SC	SC	Multi-function digital input selection common	Sequence Common	
-	SP	Multi-function digital input power supply +24 Vdc	-	
H1	H1	Safe Disable input 1	Open: Output disabled Closed: Normal operation Note: Disconnect wire jumper between HC and H1 when using the safe disable input. The wire length should not exceed 30 m.	Remove the jumper between terminals H1-HC and H2-HC to use the Safe Disable input. • 24 V, 6 mA • ON: Normal operation • OFF: Coasting motor • Internal impedance 4.7 kΩ • OFF Minimum OFF time of 3 ms
-	H2	Safe Disable input 2	-	
HC	HC	Safe Disable function common	+24 Vdc (Maximum 10 mA)	Safe Disable function common NOTICE: Do not close the circuit between terminals HC and SN. A closed circuit between these terminals will cause damage to the drive.

Control Circuit Terminals		Name	Signal Level	
V1000	GA500		V1000	GA500
RP	RP	Master frequency reference pulse train input	Response frequency: 0.5 to 32 kHz (Duty Cycle: 30 to 70%) (High level voltage: 3.5 to 13.2 Vdc) (Low level voltage: 0.0 to 0.8 Vdc) (Input impedance: 3 kΩ)	Response frequency: 0.5 to 32 kHz (Duty Cycle: 30 to 70%) (High level voltage: 3.5 to 13.2 Vdc) (Low level voltage: 0.0 to 0.8 Vdc) (Input impedance: 3 kΩ)
		(Master frequency reference)		
+V	+V	Power supply for frequency setting	+10.5 Vdc (Allowable current 20 mA maximum)	+10.5 Vdc (Allowable current 20 mA maximum)
A1	A1	Multi-function analog input 1	Input voltage 0 to +10 Vdc (20 kΩ) resolution 1/1000	Voltage input Use H3-01 [Terminal A1 Signal Level Select] to select the signal level. • 0 V to 10 V/100% (input impedance: minimum 15 kΩ) • -10 V to +10 V/-100% to +100% (Input impedance: minimum 15 kΩ)
		Master frequency reference		
A2	A2	Multi-function analog input 2	Input voltage or input current (Selected by DIP switch S1 and H3-09) 0 to +10 Vdc (20 kΩ), Resolution: 1/1000 4 to 20 mA (250 Ω) or 0 to 20 mA (250 Ω) Resolution: 1/500	Voltage input or current input Use DIP switch S1 and H3-09 [Terminal A2 Signal Level Select] to select the input. 0 V to 10 V/100% (Input impedance: minimum 15 kΩ) -10 V to +10 V/-100% to +100% (Input impedance: Minimum 15 kΩ) 4 mA to 20 mA/100%, 0 mA to 20 mA/100% (Input impedance: 250 Ω)
		(Combined to terminal A1)		
AC	AC	Frequency reference common	0 V	0 V
E (G)	E (G)	Connecting shielded cable	-	-
MA	MA	N.O. output	Relay output 30 Vdc, 10 mA to 1 A	Relay output 30 Vdc, 10 mA to 1 A
		(Fault)		
MB	MB	N.C. output	250 Vac, 10 mA to 1 A Minimum load: 5 Vdc, 10 mA (Reference value)	250 Vac, 10 mA to 1 A Minimum load: 5 Vdc, 10 mA (Reference value)
		(Fault)		
MC	MC	Digital output common		
P1	P1	Multi-function photocoupler output 1	Photocoupler output 48 Vdc, 2 to 50 mA	Photocoupler output 48 V, 2 to 50 mA
-	C1	(During RUN)		
P2	P2	Multi-function photocoupler output 2		
-	C2	(Speed agree 1)		
PC	-	Photocoupler common		
MP	MP	Pulse train output	32 kHz (Maximum)	32 kHz (Maximum)
		(Output frequency)		

6 Control Circuit Wiring

Control Circuit Terminals		Name	Signal Level	
V1000	GA500		V1000	GA500
AM	AM	Analog monitor output	0 to 10 Vdc (2 mA or less) Resolution: 1/1000	Select voltage or current output. 0 V to 10 V/0% to 100% 4 mA to 20 mA (Receiver recommended impedance: 250 Ω) Note: Use jumper S5 and H4-07 [Terminal AM Signal Level Select] to set the signal type.
		(Output frequency)		
AC	AC	Monitor common	0 V	0 V
-	PS	External 24 V power supply input	-	Supplies backup power to the drive control circuit, keypad, and option board. 21.6 Vdc to 26.4 Vdc, 700 mA
-	AC	External 24 V power supply ground	-	0 V
Serial Communication Terminal		Name	Signal Level	
V1000	GA500		V1000	GA500
R+	D+	Communications input (+)	RS-485/422 MEMOBUS/ Modbus communication protocol 115.2 kbps (Maximum)	RS-485 MEMOBUS/ Modbus communication protocol 115.2 kbps (Maximum)
R-	D-	Communications input (-)		
S+	D+	Communications output (+)		
S-	D-	Communications output (-)		
IG	AC	Shield ground	0 V	0 V

Table 11 Control Circuit Terminal Sizes and Wire Gauge

Model	Capacity	Terminal Symbol	Screw	Tightening Torque N•m (lb-in)	Bare Wire		Crimp Ferrule	
					Recommended Gauge mm ² (AWG)	Wire Range mm ² (AWG)	Recommended Gauge mm ² (AWG)	Wire Range mm ² (AWG)
V1000	All capacities	S1-S7, SC, RP, +V, A1, A2, AC, HC, H1, P1, P2, PC, MP, AM, AC, S+, S-, R+, R-, IG	M2	0.22 to 0.25 (1.9 to 2.2)	0.75 (18)	Stranded wire: 0.25 to 1.0 (24 to 18) Solid wire: 0.25 to 1.5 (24 to 16)	0.25 to 0.5 (24 to 20)	0.5 (20)
		MA, MB, MC	M3	0.5 to 0.6 (4.4 to 5.3)	0.75 (18)	Stranded wire: 0.25 to 1.5 (24 to 16) Solid wire: 0.25 to 1.5 (24 to 16)	0.25 to 1.0 (24 to 17)	0.5 (20)
GA500	All capacities	PS, S1 - S7, SN, SC, SP, AM, AC, A1, A2, +V, H1, H2, HC, MP, RP, AC, D+, D-, P1, C1, P2, C2	M2	0.22 - 0.25 (1.95 - 2.21)	0.75 (18)	Stranded wire: 0.25 - 1.0 (24 - 17) Solid wire: 0.25 - 1.5 (24 - 16)	0.5 (20)	0.25 - 0.5 (24 - 20)
		MA, MB, MC	M3	0.5 - 0.6 (4.4 - 5.3)	0.75 (18)	Stranded wire: 0.25 - 1.5 (24 - 16) Solid wire: 0.25 - 1.5 (24 - 16)	0.5 (20)	0.25 - 1.0 (24 - 17)

◆ Control Circuit Switches and Jumpers

Use this section to make any needed changes to the GA500 control circuit switches or jumpers.

■ V1000 Switches and Jumpers

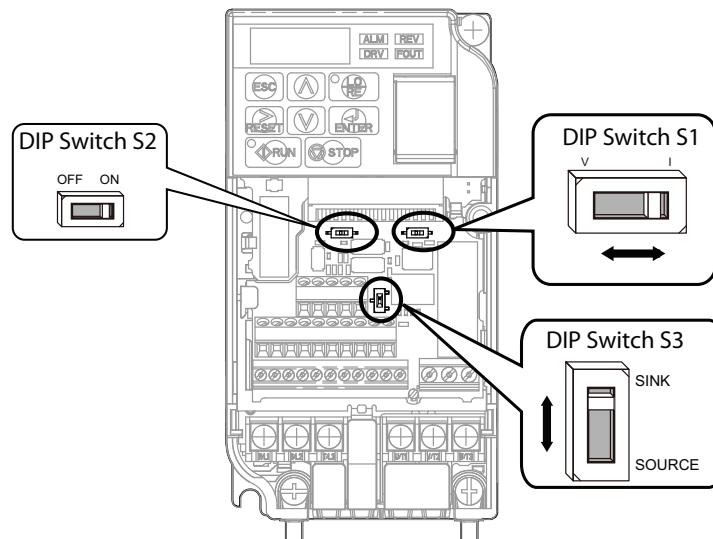

Figure 8 V1000 DIP Switches

Table 12 V1000 DIP Switch Settings

DIP Switch	Switch Function	Setting Value	DIP Switch Setting Description
S1	Analog input signal selection for voltage or current for terminal A2	V (left position)	Voltage input (0 to 10 V)
		I (right position)	Current input (4 to 20 mA or 0 to 20 mA): default setting
S2	MEMOBUS/Modbus termination resistor switch setting for the RS-485, RS-422 communication terminals R-, R+, S-S+	ON	Internal termination resistor ON
		OFF	Internal termination resistor OFF (no termination resistor): default setting
S3	Sinking/sourcing mode switch for digital input terminals S1~S7	SINK	Sinking Mode (0 V common): default setting
		SOURCE	Sourcing Mode (+24 V common)

GA500 Switches and Jumpers

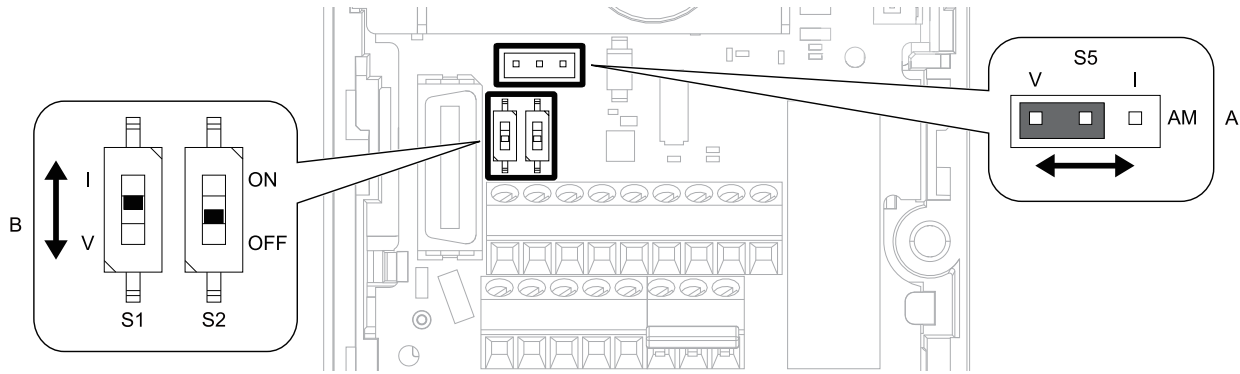

Figure 9 GA500 Switches and Jumpers

Table 13 GA500 Switch and Jumper Settings

Switch or Jumper	GA500 Terminal	Default Setting Value	DIP Switch Setting Description
DIP SW S1	A2	I (current input)	Sets the input method for terminal A2 (voltage or current).
DIP SW S2	-	OFF	Enables and disables the MEMOBUS/Modbus communications termination resistor.
Jumper S5	AM	V (voltage output)	Sets the output method for terminal AM (voltage or current).

7 Transfer of Parameter Settings

Use this section to transfer V1000 parameter settings to the GA500. There are several methods to transfer parameters.

- **Transfer Parameters via DriveWizard Industrial PC Software on page 28** (recommended)
Yaskawa recommends the use of DriveWizard Industrial to transfer parameters.
- **Procedure - Manual Transfer of V1000 Parameters to the GA500 using the Keypad on page 31**

◆ Transfer Parameters via DriveWizard Industrial PC Software

The DriveWizard® Industrial support tool is a Windows-based PC program designed to make commissioning and troubleshooting of Yaskawa drives as simple as possible. DriveWizard® Industrial provides user-friendly tools for viewing, manipulating, and exchanging data with the drive. Data can be retrieved, changed, stored, and graphed. DriveWizard® Industrial is also used to transfer parameters from previous generation drives to new ones.

DriveWizard Industrial is compatible with the GA500, GA800, A1000, P1000, U1000, V1000, V1000-4X, J1000, D1000, R1000, F7, P7, G7 and G5 Low HP.

Request a free copy of DriveWizard Industrial PC software here:

<https://www.yaskawa.com/ad-campaign~promoCode=drivewizard-industrial>

DriveWizard Industrial product page on yaskawa.com:

<https://www.yaskawa.com/products/drives/industrial-ac-drives/industrial-software-tools/drivewizard-industrial>



The screenshot displays the "Drive Converter" software window. The main area contains the following information:

- Drive Information:**
 - Drive Series: A1000
 - Software Version: 1026
 - Model: CIMR-A*2*0004***
 - Control Method: Open Loop Vector
- Drive Duty Cycle:**
 - Normal Duty
 - Normal Duty 2
 - Heavy Duty
- Select drive series, software version and model to convert to:**
 - Drive Series: GA800
 - Software Version: 09010
 - Model: CIPR-GA80*2004****
- Convert non-KVA related parameters only
- Convert modified parameters only

An "Important please read:" box contains the following text: "This function automatically suggests a model based on the selected drive series, model and duty cycle. Control method of the converted project will be the same as control method of the original project when applicable. This function will attempt to convert a drive series project to a new drive series project. Drive rating selection is based on nominal motor power for the drive. Please verify all parameters after conversion is completed."

At the bottom, there are buttons for "Help", "Transfer converted data to the active project", and "Cancel".

The project converter function will suggest a model based on the selected drive series, model and duty cycle. Once a selection has been made click on the Go button to start the conversion process.

The screenshot shows the YASKAWA software interface. At the top, there is a navigation bar with 'FILE', 'HOME', 'EDIT', 'STARTUP AND DIAGNOSTICS', 'TOOLS', and 'HELP'. Below this, a 'Tools' section contains three icons: 'Application Wizard', 'Network Configurator', and 'Convert Project'. The 'Convert Project' icon is highlighted with a mouse cursor. Below the navigation bar is a blue header with the 'YASKAWA' logo. The main interface is divided into two panes. The left pane shows a tree view of parameter groups under 'Parameter Groups A1000', including sub-groups like 'A: Initialization', 'B: Application', 'C: Tuning', 'D: Instructions', 'E: Motor Parameter', 'F: Option', 'H: Terminal Function Selection', 'L: Protection Function Selection', 'N: Special Adjustment', 'O: Operator Relation', 'Q: DWEZ Parameter', 'R: Connection Data', 'Modified Parameters', and 'Monitors A1000'. The right pane has tabs for 'Overview', 'Export', and 'E-Mail'. Below the tabs are buttons for 'Preview', 'Print', and 'Edit Parameter'. A text prompt says 'Click Preview to review parameter or monitor print-out.' Below this is a table titled 'Parameter Groups A1000'.

No.	Parameter
A1-01	Access level
A1-02	Control method
A1-04	Enter password
A1-06	Select application
A1-07	...

7 Transfer of Parameter Settings

■ About DriveWizard Mobile for Android and iOS

DriveWizard Mobile is DriveWizard for mobile devices. It does not have a feature to transfer parameters between V1000 and GA500, but it is very useful for commissioning GA500 drives with your smartphone or tablet.

Start-up, adjust, and monitor Yaskawa GA500 AC drives with your smartphone or tablet. Use DriveWizard® Mobile to backup, store, and retrieve your drive settings locally or to your personal Yaskawa Drive Cloud™ account. DriveWizard Mobile is the mobile app version of DriveWizard® Industrial.

Get DriveWizard Mobile here: <https://www.yaskawa.com/dwm>

Get the App



DriveWizard Mobile for Android



► Requires 4.4 or later



DriveWizard Mobile for iOS



► Requires iOS 10.0 or later
► Compatible with iPhone, iPad, and iPod Touch



◆ Procedure - Manual Transfer of V1000 Parameters to the GA500 using the Keypad

An easy way to view which V1000 parameters differ from factory settings is to use the V1000 **urFy** or **verify** menu. If no parameters differ from factory settings then the V1000 will display “None”. Record the parameters and their settings in a log so they can be manually entered into the replacement GA500 drive.

This procedure is also available in video format on YouTube.



- **YouTube Video title:** Checking modified parameter settings in V1000 and J1000
- **YouTube Video URL:** <https://youtu.be/5vbZW10X7Wc>

Table 14 Viewing Modified Parameters on the V1000 Drive

Step	Key Press	V1000 Display	Description/Action
1	[ESC]	F xx.xx	Press until left-most digit is "F" (Freq Ref) followed by numbers. Consider this "Home Base".
2	[DOWN]	"urFy"	Points to Drive's VERIFY menu. Note: Press [Down] x 4 on the V1000.
3	[ENTER]	"xx-xx"	Display will show the most recently viewed "modified" Parameter. Note: all digits are flashing.
4	[UP]/[DOWN]	"xx-xx"	Using arrows, scroll through the "modified" parameter(s).
5	[ENTER]	Modified value	Displays selected Parameter's current "modified" value.
6	Write down the modified parameters and settings in a log for reference when transferring settings to the replacement GA500 drive.		
7	[ESC]	"xx-xx"	Displays selected "modified" Parameter.
8	Repeat previous three keystrokes to view other "modified" parameters and their values.		
9	[ESC] x 2	F xx.xx	Press until left-most digit is "F" (Freq Ref) followed by Frequency Reference. Consider this "Home Base".
The V1000 drive is now back at the ready state and can be replaced with the new GA500 drive. Follow all safety precautions in the V1000 and GA500 manuals when replacing your drive.			
10	Use the log you made in Step 6 as your reference to program the same parameters into the replacement GA500. Follow the GA500 instruction manual for parameter setting procedures.		
Procedure complete.			

7 Transfer of Parameter Settings

◆ Parameters with Default Value or Setting Range Differences

Some of the setting ranges and default settings for certain parameters differ between V1000 and GA500.

Table 15 only lists **setting range or default setting differences** between similar V1000 and GA500 parameters. **Table 15** is not a comprehensive comparison of all parameter differences between V1000 and GA500. For example, GA500 parameters that have no equal in the V1000 are omitted.

Table 15 Parameters with Setting Range or Default Value Differences

Reg. No.	Param. No.	Name	Description	Setting Range		Initial Setting		Base	Unit
				GA500	V1000	GA500	V1000		
0x0100	A1-00	Language Selection	Language selection for the digital operator. This parameter is not reset when the drive is initialized by parameter A1-03. 0: English 1: Japanese 2: German 3: French 4: Italian 5: Spanish 6: Portuguese 7: Chinese 8: Czech 9: Russian 10: Turkish 11: Polish 12: Greek	0~12	0~7	02-09 Depend	02-09 Depend	DEC	
0x0101	A1-01	Access Level Selection	Restricts user access to parameter settings. The set access level restricts what parameters the keypad will display, and what parameters the user can set. 0: Operation Only 1: User Parameters 2: Advanced Level 3: Expert Level	0~3	0~2	2	2	DEC	
0x0102	A1-02	Control Method Selection	Selects the Control Method of the drive. 0: V/f Control without PG 2: Open Loop Vector 5: PM Open Loop Vector 8: EZ Vector Note: Does not return to the default setting when the drive is initialized.	0,2,5,6,8	0, 2, 5	02-09 Depend	0	DEC	
0x0103	A1-03	Initialize Parameters	Resets parameters to default values. 0: Keypad or Multi-Speed Selection 1110: User Initialization 2220: 2-Wire initialization 3330: 3-Wire initialization	0,1110,2220,3330	0, 1110, 2220, 3330, 5550	0	0	DEC	
0x0189	B2-01	DC Injection Braking Start Frequency	Sets the frequency at which DC Injection braking starts when Ramp to Stop (b1-03 = 0) is selected. If b2-01 < E1-09, DC Injection braking starts at E1-09. Note: Zero Speed restrictions are active in Flux Loop Vector Mode.	0.0~10.0	0.0~10.0	A1-02 Depend	0.5	DEC	Hz
0x01BB	B2-13	Short Circuit Brake Time at Stop	Sets the time for Short-Circuit Brake operation at stop in units of 0.01 s. Used to stop a motor rotating due to inertia. Disabled when set to 0.00.	0.00~25.50	0.00~25.50	A1-02 Depend	0.50	DEC	sec

7 Transfer of Parameter Settings

Reg. No.	Param. No.	Name	Description	Setting Range		Initial Setting		Base	Unit
				GA500	V1000	GA500	V1000		
0x019E	B3-14	Bi-Directional Speed Search Selection	This parameter enables the drive to detect the motor direction during speed search. 0: Disabled. Drive uses frequency reference direction. 1: Enabled. Drive uses detected direction	0~1	0~1	A1-02 Depend 0	0	DEC	
0x01C0	B3-24	Speed Search Method Selection	This parameter is select of Speed search for start or recovery of power failure. 1: Speed estimation type 2: Current detection type	1~2	0~1	A1-02 Depend 0	0	DEC	
0x01A3	B4-01	Timer Function On-Delay Time	Used in conjunction with a multi-function digital input and a multi-function digital output programmed for the timer function. This sets the amount of time between when the digital input is closed, and the digital output is enabled.	0.0~3000.0	0.0~300.0	0.0	0.0	DEC	sec
0x01A4	B4-02	Timer Function Off-Delay Time	Used in conjunction with a multi-function digital input and a multi-function digital output programmed for the timer function. This sets the amount of time the output remains enabled after the digital input is opened.	0.0~3000.0	0.0~300.0	0.0	0.0	DEC	sec
0x01A5	B5-01	PID Function Setting	This parameter determines the function of the PID control. 0: Disabled 1: D = Feedback 2: D = Feed-Forward 3: Freq. Ref. + PID output (D = Feedback) 4: Freq. Ref. + PID output (D = Feed-Forward) 5: Same as Setting 1 w/ G7 Mode 6: Same as Setting 2 w/ G7 Mode 7: Same as Setting 3 w/ G7 Mode 8: Same as Setting 4 w/ G7 Mode	0~8	0~4	0	0	DEC	
0x01B3	B5-15	PID Sleep Function Start Level	Sets the sleep function start frequency. Note: Enabled even when PID control mode has not been selected.	0.0~590.0	0.0~400.0	A1-02 Depend (all 0.0)	0.0	DEC	Hz
0x01B5	B5-17	PID Accel/Decel Time	Applies an accel/decel time to the PID setpoint reference. The drive's standard softstarter (C1-xx and S-curve) still affects the output of the PID algorithm.	0.0~6000.0	0~255	0.0	0.0	DEC	sec
0x01B6	B6-01	Dwell Reference at Start	The Dwell function is used to temporarily hold the frequency when driving a motor with heavy load. Parameters b6-01 and b6-02 set the frequency to hold and the time to maintain that frequency at start. Parameters b6-03 and b6-04 do the same at top.	0.0~590.0	0.0~400.0	A1-02 Depend (all 0.0)	0.0	DEC	Hz
0x01B8	B6-03	Dwell Frequency at Stop	The Dwell function is used to temporarily hold the frequency when driving a motor with heavy load. Parameters b6-01 and b6-02 set the frequency to hold and the time to maintain that frequency at start. Parameters b6-03 and b6-04 do the same at top.	0.0~590.0	0.0~400.0	A1-02 Depend (all 0.0)	0.0	DEC	Hz

7 Transfer of Parameter Settings

Reg. No.	Param. No.	Name	Description	Setting Range		Initial Setting		Base	Unit
				GA500	V1000	GA500	V1000		
0x01CC	B8-01	Energy Saving Control Selection	Energy Savings function enable/disable selection. 0: Disabled 1: Enabled (set b8-04) 2: PM Energy-saving control	0~2	0~1	A1-02 Depend (all 0)	0	DEC	
0x020A	C1-11	Accel/Decel Switch Frequency	Sets the frequency at which acceleration and deceleration times are automatically changed.	0.0~590.0	0.0~400.0	A1-02 Depend (all 0)	0.0	DEC	Hz
0x0264	C1-14	Picking up speed and slowing down rate setting standard frequency	Sets the base frequency used to calculate acceleration and deceleration rates.	0.0~590.0	0.0~400.0	0.0	0.0	DEC	Hz
0x0212	C3-04	Slip Compensation Selection during Regeneration	Enables or disables slip compensation during regenerative operation. 0: Disabled 1: Enabled (6 Hz and above) 2: Enabled (compensation provided wherever possible)	0~2	0~1	0	0	DEC	
0x021C	C5-02	ASR Integral Time 1	Sets the integral time of the speed control loop. (ASR)	0.000~60.000	0.000~10.000	A1-02 Depend	A1-02 Depend	DEC	sec
0x021E	C5-04	ASR Integral Time 2	Sets the speed control gain 2 and integral time 2 of the speed control loop (ASR). Note: Adjustment is not normally required.	0.000~60.000	0.000~10.000	A1-02 Depend	A1-02 Depend	DEC	sec
0x0221	C5-07	ASR Gain Switching Frequency	Sets the frequency for switching between Proportional Gain 1, 2 and Integral Time 1, 2. When ASR switch is set to one of the multi-function input terminals, that switching value take priority.	0.0~400.0	0.0~400.0	A1-02 Depend (all 0)	0.0	DEC	Hz
0x0280	D1-01~17	Frequency Reference 1~17	Setting units are determined by o1-03.	0.00~590.00	0.00~400.00	0.00	0.00	DEC	O1-03
0x0294	D3-01~3	Jump Frequency 1~3	Sets the median value of the specific frequency band that needs to be jumped.	0.0~590.0	0.0~400.0	A1-02 Depend (all 0)	0.0	DEC	Hz
0x0297	D3-04	Jump Frequency Width	This parameter determines the width of the deadband around each selected prohibited frequency reference point. A setting of "1.0" will result in a deadband of +/- 1.0 Hz.	0.0~20.0	0.0~20.0	A1-02 Depend (all 1.0)	1.0	DEC	Hz
0x0303	E1-04	Max Output Frequency (FMAX)	Sets the maximum output frequency for the V/f pattern.	40.0~590.0	40.0~400.0	A1-02,E1-03,O2-09,E5-01 Depend	A1-02,E1-03,O2-09,E5-01 Depend	DEC	O1-04
0x0305	E1-06	Bass Frequency (FA)	Sets the base frequency for the V/f pattern.	0.0~590.0	0.0~400.0	A1-02,E1-03,O2-09,E5-01 Depend	A1-02,E1-03,O2-09,E5-01 Depend	DEC	O1-04
0x0306	E1-07	Mid Output Frequency (FB)	Sets the middle output frequency.	0.0~590.0	0.0~400.0	A1-02,E1-03,O2-09 Depend	A1-02,E1-03,O2-09 Depend	DEC	O1-04
0x0308	E1-09	Minimum Output Frequency (FMIN)	Sets the minimum output frequency for the V/f pattern.	0.0~590.0	0.0~400.0	A1-02,E1-03,O2-09,E5-01 Depend	A1-02,E1-03,O2-09,E5-01 Depend	DEC	O1-04
0x030A	E1-11	Mid Output Frequency 2	Set only when fine tuning the V/f pattern within the constant power (HP) range above base speed. This value seldom needs to be changed.	0.0~590.0	0.0~400.0	A1-02,E1-03,O2-09 Depend	A1-02,E1-03,O2-09 Depend	DEC	O1-04
0x0311	E2-04	Number of Motor Poles	Sets the number of motor poles. This value is automatically set during Auto-Tuning.	2~120	2~48	4	4	DEC	

7 Transfer of Parameter Settings

Reg. No.	Param. No.	Name	Description	Setting Range		Initial Setting		Base	Unit
				GA500	V1000	GA500	V1000		
0x0313	E2-06	Motor Leakage Inductance	Sets the voltage drop due to motor leakage inductance as a percentage of motor rated voltage. This value is automatically set during Auto-Tuning.	0.0~60.0	0.0~40.0	kVA Depend	kVA Depend	DEC	%
0x031A	E3-04	(FMAX)	Sets the maximum output frequency used for motor 2.	40.0~590.0	40.0~400.0	A1-02, O2-09,kVA Depend	A1-02, O2-09,kVA Depend	DEC	O1-04
0x031C	E3-06	Motor 2 Base Frequency (FA)	Sets the base frequency used for motor 2.	0.0~590.0	0.0~400.0	A1-02, O2-09,kVA Depend	A1-02, O2-09,kVA Depend	DEC	O1-04
0x031D	E3-07	Motor 2 Minimum Output Frequency (FB)	Sets the middle output frequency used for motor 2.	0.0~590.0	0.0~400.0	A1-02, O2-09,kVA Depend	A1-02, O2-09,kVA Depend	DEC	O1-04
0x031F	E3-09	Motor 2 Minimum Output Frequency (FMIN)	Sets the minimum output frequency used for motor 2.	0.0~590.0	0.0~400.0	A1-02, O2-09,kVA Depend	A1-02, O2-09,kVA Depend	DEC	O1-04
0x0345	E3-11	Motor 2 Mid Output Frequency 2	Used only for fine-tuning the V/f ratio within the rated output range. This setting rarely needs to be changed.	0.0~590.0	0.0~400.0	A1-02, O2-09,kVA Depend	A1-02, O2-09,kVA Depend	DEC	O1-04
0x0324	E4-04	Motor 2 Motor Poles	Sets the number of poles of motor 2. This value is automatically set during Auto-Tuning.	2~120	2~48	4	4	DEC	
0x0326	E4-06	Motor 2 Leakage Inductance	Sets the voltage drop due to motor leakage inductance as a percentage of rated voltage of motor 2. This value is automatically set during Auto-Tuning.	0.0~60.0	0.0~40.0	kVA Depend	kVA Depend	DEC	%
0x032C	E5-04	Motor Poles (for PM motor)	Sets the number of motor poles.	2~120	2~48	E5-01 Depend	E5-01 Depend	DEC	
0x0381	F1-02	Operation Selection at PG Open Circuit (PGO)	Selects the motor operation when PGo [PG Disconnect] is detected. 0: Ramp to stop 1: Coast to stop 2: Fast Stop (use C1-09) 3: Alarm only 4: No alarm display	0~4	0~3	1	1	DEC	
0x03A5	F6-04	Trace Sampling from Communications Option Board	Sets the delay time until bUS [Option Communication Error] issues are detected.	0.0~12.0	0.0~5.0	2.0	2.0	DEC	sec
0x040B	H2-01	Terminals MA, MB, and MC Function Selection (relays)	Terminals MA, MB, and MC Function Selection (relays)	0x0~0x1A7	0x0~0x192	0x00E	0x00E	HEX	
0x040C	H2-02	Terminals P1 Function Selection (open-collector)	Terminals P1 Function Selection (open-collector)	0x0~0x1A7	0x0~0x192	0x000	0x000	HEX	
0x040D	H2-03	Terminals P2 Function Selection (open-collector)	Terminals P2 Function Selection (open-collector)	0x0~0x1A7	0x0~0x192	0x002	0x002	HEX	
0x042A	H5-06	Drive Transmit Wait Time	Set the delay time from when the drive receives data to when the drive sends data.	0~65	5~65	5	5	DEC	ms
0x0435	H5-09	CE Detection Time	Sets the time required to detect a communications error. Adjustment may be need when networking several drives.	0.0~25.0	0.0~10.0	2.0	2.0	DEC	sec

7 Transfer of Parameter Settings

Reg. No.	Param. No.	Name	Description	Setting Range		Initial Setting		Base	Unit
				GA500	V1000	GA500	V1000		
0x0431	H6-06	Terminal MP Pulse Train Monitor Selection	Selects a function for the pulse train monitor output terminal MP. Inputs the "x-xx" portion of the Ux-xx parameter to be monitored.	0,31,101,102,105,116,501,502,702,801~809,821~825,831~839,851~855	0,31,101,102,105,116,501,502,801~809	102	102	DEC	
0x0480	L1-01	Motor Overload Protection Selection	Enables or disables the motor overload protection using electronic thermal protectors. 0: Disabled 1: Variable Torque 2: Constant Torque 10:1 Speed Range 3: Constant Torque 100:1 Speed Range 4: PM Variable Torque 5: PM Constant Torque 6: Variable Torque (50Hz)	0~6	0~4,6	A1-02 Depend	A1-02 Depend	DEC	
0x0485	L2-01	Momentary Power Loss Operation Selection	Selects the drive operation performed when a momentary power loss occurs. 0: Disabled 1: Enbl with Timer 2: Enbl whl CPU act 3: KEB Mode 4: KEB Stop Mode 5: KEB Decel to Stp	0~5	0~2	0	0	DEC	
0x048A	L2-06	KEB Deceleration Time	Sets the time required to decelerate to zero speed when a KEB command is input from a multi-function input terminal.	0.0~6000.0	0.0~200.0	0.0	0.0	DEC	sec
0x048B	L2-07	Momentary Power Loss Ridethru Time	Set the time (in seconds) to accelerate to the set speed after recovery from a momentary power loss. If setting = 0.0, then active acceleration time is used instead.	0.0~6000.0	0.0~25.5	0.0	0.0	DEC	sec
0x048E	L2-10	KEB Detection Time	Sets the minimum duration to operate the KEB after a momentary power loss is detected.	0~25500	0~2000	50	50	DEC	ms
0x048F	L3-01	Stall Prevention Selection during Acceleration	Selects the method of the Stall Prevention During Acceleration function. 0: Disabled 1: General Purpose 2: Automatic Decel Reduction 3: ILim Mode	0~3	0~2	1	1	DEC	
0x0493	L3-05	Stall Prevention Selection during Run	Enables or disables the Stall Prevention During Run function. 0: Disabled 1: Decel Time 1 2: Decel Time 2 3: Intelligent	0~3	0~2	A1-02 Depend	1	DEC	
0x0494	L3-06	Stall Prevention Level during Run	This parameter is enabled when L3-05 is set to "1" or "2". Drive rated current is set as 100%. Decrease the set value if stalling or excessive current occurs with the default settings.	5~150	30~150	C6-01, L8-38 Depend	C6-01, L8-38 Depend	DEC	%
0x0466	L3-21	Acceleration Deceleration Rate Calculation Gain	Sets the proportional gain used to calculate acceleration and deceleration rates.	0.10~10.00	0.00~200.00	A1-02 Depend	A1-02 Depend	DEC	
0x046F	L3-25	Load Inertia Ratio	Sets the ratio between the connected machinery and the motor.	0.1~1000.0	0.0~1000.0	1.0	1.0	DEC	
0x0456	L3-27	Pre-Stall Acceleration Time	Pre-Stall Acceleration Time	0~5000	20~150	60	60	DEC	ms

7 Transfer of Parameter Settings

Reg. No.	Param. No.	Name	Description	Setting Range		Initial Setting		Base	Unit
				GA500	V1000	GA500	V1000		
0x0499	L4-01	Speed Agreement Detection Level	Sets the speed agree detection level or the motor speed detection level.	0.0~590.0	0.0~400.0	A1-02 Depend (all 0.0)	0.0	DEC	Hz
0x049A	L4-02	Speed Agreement Detection Width	Sets the speed agree detection width or motor speed detection width.	0.0~20.0	0.0~20.0	A1-02 Depend	2.0	DEC	Hz
0x049B	L4-03	Speed Agreement Detection Level(+/-)	Sets the speed agree detection leveler the motor speed detection level.	-590.0~590.0	-400.0~400.0	A1-02 Depend (all 0.0)	0.0	DEC	Hz
0x049C	L4-04	Speed Agreement Detection Width (+/-)	Sets the speed agree detection width or motor speed detection width.	0.0~20.0	0.0~20.0	A1-02 Depend	2.0	DEC	Hz
0x04AE	L8-02	Overheat Alarm Level	When the heatsink temperature exceeds the value set in this parameter, an Overheat Alarm (OH) will occur. Requires that one of the multi-function digital output terminals (H2-xx) be set to 20.	50~150	50~130	kVA Depend	kVA Depend	DEC	°C
0x04B6	L8-10	Heatsink Cooling Fan Operation Selection	Controls the heatsink cooling fan operation. 0: Fan On-Run Mode - Fan will operate only when the drive is running and for L8-11 seconds after RUN is removed. 1: Fan always on - Cooling fan operates whenever the drive is powered up 2: Fan ON in heating of Drive - Fan runs when drive main circuit overheat is detected	0~2	0~1	0	0	DEC	
0x04E1	L8-31	Current Unbalance Detection Current Level	Sets the current level to activate Current Unbalance Protection Detection function with the drive rated current at 100%.	1~100	0.0~100.0	3	30.0	DEC	
0x04EC	L8-35	Side-by-Side Selection	0: Disabled (standard installation). 1: Side-by-Side installation. 2:NEMA 1 Type 1 enclosure 3: Finless / Fin outside	0~3	0~3	0	kVA, O2-09 Depend	DEC	
0x04F1	L8-40	Low Carrier Frequency Time	Sets the amount of time the drive will operate with a reduced carrier frequency. The carrier frequency derating function during run is disabled when this parameter is set to 0.00 s.	0.00~2.00	0.00~2.00	A1-02 Depend	0.50	DEC	sec
0x0471	L8-51	STPo I Detection Level	Sets the STPo [De-synchronization Error] on the basis of the output current.	0.0~300.0	0.0~150.0	0.0	0.0	DEC	%
0x0589	N3-02	High Slip Braking Current Limit	Sets the maximum current to be drawn during an HSB stop. Higher n3-02 settings will shorten motor stopping times but cause increased motor current, and therefore increased motor heating.	0~200	100~200	C6-01, L8-38 Depend	150	DEC	%
0x0570	N6-01	Line-to-Line Motor Resistance Online Tuning	Tunes the line-to-line motor resistance online. 0: Disabled 1: Enabled (Line-to-line resistance tuning) 2: Enabled (Voltage Adjustm) In with PG vector control (A1-02 = 3), it is not possible to enable the resistance online adjustment only. There is a need to set C3-28=2.	0~2	0~1	0	1	DEC	
0x0563	N8-36	Superimposed Harmonic Frequency	Sets the frequency in Hz for the superimposed signal used for superimposed harmonics.	200~5000	200~1000	500	500	DEC	Hz

7 Transfer of Parameter Settings

Reg. No.	Param. No.	Name	Description	Setting Range		Initial Setting		Base	Unit
				GA500	V1000	GA500	V1000		
0x0568	N8-41	Superimposed Harmonic Polarity Estimation Proportional Gain	Sets the P gain for PI control used to estimate polarity. There is usually no need to change. You set the response of the speed estimation for high frequency injection. N8-57 (high frequency superimposed selection) is valid at the time of the 1. Unit [Hz]	1.0~100.0	-10.00~10.00	3.0	1.00	DEC	Hz
0x0569	N8-42	Integral Time for Superimposed Harmonic Polarity Estimation	Sets the integral time in 0.01 sec units for PI control used to estimate polarity. There is usually no need to change. You set the damping factor of the speed estimation for high frequency injection. N8-57 (high frequency superimposed selection) is valid at the time of the 1. Unit is [-]	0.1~5.0	0.00~9.99	1.0	0.01	DEC	
0x053E	N8-51	Acceleration Time Pull-In Current*	Sets the pull-in current during acceleration as a percentage of the motor rated current (E5-03). Set to a high value when more starting torque is needed.	0~200	0~200	A1-02 Depend	50	DEC	%
0x05C3	N8-74	Light Load Iq Level	Set n8-48 [Pull-in/Light Load Id Current] to the level of the load current (q-axis current) to be applied.	0~255	0.0~250.0	30.0	30.0	DEC	%
0x05C4	N8-75	Medium Load Iq Level (low)	Set n8-78 [Medium Load Id Current] to the level of the load current (q-axis current) to be applied.	0~255	0.0~250.0	50.0	50.0	DEC	%
0x05CE	N8-77	Heavy Load Iq Level	Set n8-49 [Heavy Load Id Current] to the level of the load current (q-axis current) to be applied.	0~255	0.0~250.0	90.0	90.0	DEC	%
0x05F4	N8-78	Medium Load Id Current	Sets the level of the pull-in current for midrange loads.	0~255	-200.0~200.0	0.0	0.0	DEC	%
0x0500	O1-01	Drive Mode Unit Monitor Selection	Sets the U monitor that shows in Drive Mode. This parameter is only enabled for LED keypads.	104~855	104~813	106	106	DEC	
0x0502	O1-03	Digital Operator Display Selection	Selects the display units for the frequency reference and output frequency. 0: 0.01 Hz 1: 0.01% (100% = E1-04) 2: r/min 3: User-selected units	0~3	0~3	A1-02 Depend	0	DEC	
0x0504	O1-05	LCD Contrast	Sets the contrast of the digital operator LCD. A setting of "0" is the lightest contrast and a setting of "10" is the darkest contrast. 5: Normal contrast	0~10	0~5	5	3	DEC	
0x164A	Q2-11	Drive U1 Monitor Select 1	Drive U1 Monitor Select 1	0~21	0~3, 6~13	0	0	DEC	
0x164B	Q2-12	Drive U1 Monitor Select 2	Drive U1 Monitor Select 2	0~21	0~3, 6~13	0	0	DEC	
0x0701	T1-01	Auto-Tuning Mode Selection	Selects the type of Auto-Tuning to be used. 0: Rotational Auto-Tuning 1: Stationary Auto-Tuning 1 2: StaTun for LinetoLine Resistance	0~2	0, 2~3	0	0	DEC	
0x0702	T1-02	Motor Rated Power	Sets the motor rated power in kilowatts (kW). Note: If motor power is given in horsepower, power in kW can be calculated using the following formula: kW = HP x 0.746	0.00~650.00	0.03~650.00	0.40	0.40	DEC	kW

7 Transfer of Parameter Settings

Reg. No.	Param. No.	Name	Description	Setting Range		Initial Setting		Base	Unit
				GA500	V1000	GA500	V1000		
0x0705	T1-05	Motor Base Frequency	Sets the base frequency of the motor in Hertz (Hz).	0.0~590.0	0.0~400.0	60.0	60.0	DEC	Hz
0x0706	T1-06	Number of Motor Poles	Sets the number of motor poles.	2~120	2~48	4	4	DEC	
0x0707	T1-07	Motor Base Speed	Sets the base speed of the motor in revolutions per minute (RPM).	0~35400	0~24000	1750	1750	DEC	RPM
0xBdB	T1-12	Test Mode Selection	<p>Enables the Test Mode after performing Stationary Auto-Tuning. Enable this setting if it is possible to operate the motor with a light load attached after Stationary Auto-Tuning is complete.</p> <p>Note: This selection is possible when T1-10 [Motor Rated Slip Frequency] = 0 Hz. 0: No 1: Yes</p>	0~1	0~0	0	0	DEC	

8 Carrier Frequency - C6-02 [Carrier Frequency Selection]

To understand the effect of changing the Carrier Frequency on your new replacement drive, refer to the GA500 Technical Reference SIEPC71061752, Section 10.7 Drive Derating, Carrier Frequency Settings and Rated Current Values.

Download here: <http://www.yaskawa.com/SIEPC71061752>



9 Watt Loss Comparison

Use this section to understand the watt loss difference between the V1000 and GA500. This is useful to ensure proper cooling for GA500 drives that replace V1000 drives inside of enclosures.

Understanding the “Difference” columns in *Table 16* through *Table 21*.

- A positive number = GA500 has **more** watt loss compared to V1000.
- A negative number = GA500 has **less** watt loss compared to V1000.

◆ Normal Duty (Parameter C6-01=1, factory default)

Table 16 Single-Phase 240 V Models, Watt Loss Comparison

V1000					GA500					Difference		
Model	Carrier kHz	Watt Loss			Catalog Code	Carrier kHz	Watt Loss			Watt Loss		
CIMR-VU		Interior	External	Total	GA50U		Interior	External	Total	Interior	External	Total
BA0001	Swing 2 kHz	5.0	8.5	13.5	B001	2.0	8.0	6.0	14.0	3.0	-2.5	0.5
BA0002	Swing 2 kHz	7.6	9.7	17.3	B002	2.0	14.0	11.0	25.0	6.4	1.3	7.7
BA0003	Swing 2 kHz	14.6	14.4	29.1	B004	2.0	14.0	17.0	31.0	-0.6	2.6	1.9
BA0006	Swing 2 kHz	30.1	19.4	49.5	B006	2.0	17.0	26.0	43.0	-13.1	6.6	-6.5
BA0010	Swing 2 kHz	51.7	29.8	81.4	B010	2.0	36.0	50.0	86.0	-15.7	20.2	4.6
BA0012	Swing 2 kHz	61.3	37.1	98.4	B012	2.0	48.0	60.0	108.0	-13.3	22.9	9.6
BA0018	Swing 2 kHz	—	—	—	B018	2.0	49.0	92.0	141.0	N/A	N/A	N/A

Table 17 Three-Phase 240 V Models, Watt Loss Comparison

V1000					GA500					Difference		
Model	Carrier kHz	Watt Loss			Catalog Code	Carrier kHz	Watt Loss			Watt Loss		
CIMR-VU		Interior	External	Total	GA50U		Interior	External	Total	Interior	External	Total
2A0001	Swing 2 kHz	5.0	8.0	13.0	2001	2.0	7.0	5.0	12.0	2.0	-3.0	-1.0
2A0002	Swing 2 kHz	7.6	9.5	17.1	2002	2.0	9.0	9.0	18.0	1.4	-0.5	0.9
2A0004	Swing 2 kHz	15.8	13.6	29.4	2004	2.0	11.0	16.0	27.0	-4.8	2.4	-2.4
2A0006	Swing 2 kHz	27.5	17.2	44.7	2006	2.0	14.0	25.0	39.0	-13.5	7.8	-5.7
2A0010	Swing 2 kHz	51.7	25.8	77.5	2010	2.0	25.0	51.0	76.0	-26.7	25.2	-1.5
2A0012	Swing 2 kHz	61.3	30.4	91.7	2012	2.0	30.0	61.0	91.0	-31.3	30.6	-0.7
2A0020	Swing 2 kHz	98.7	46.3	145.0	2021	2.0	52.0	111.0	163.0	-46.7	64.7	18.0
2A0030	Swing 2 kHz	246.4	88.9	335.3	2030	2.0	63.0	240.0	303.0	-183.4	151.1	-32.3
2A0040	Swing 2 kHz	266.7	112.8	379.6	2042	2.0	84.0	307.0	391.0	-182.7	194.2	11.4
2A0056	Swing 2 kHz	357.9	151.8	509.7	2056	2.0	109.0	367.0	476.0	-248.9	215.2	-33.7
2A0069	Swing 2 kHz	461.7	184.5	646.2	2070	2.0	142.0	534.0	676.0	-319.7	349.5	29.8
-	-	-	-	-	2082	2.0	160.0	531.0	691.0	N/A	N/A	N/A

Table 18 Three-Phase 480 V Models, Watt Loss Comparison

V1000					GA500					Difference		
Model	Carrier kHz	Watt Loss			Catalog Code	Carrier kHz	Watt Loss			Watt Loss		
CIMR-VU		Interior	External	Total	GA50U		Interior	External	Total	Interior	External	Total
4A0001	Swing 2 kHz	10.0	9.6	19.6	4001	2.0	8.0	7.0	15.0	-2.0	-2.6	-4.6
4A0002	Swing 2 kHz	18.5	13.9	32.4	4002	2.0	13.0	12.0	25.0	-5.5	-1.9	-7.4
4A0004	Swing 2 kHz	30.5	16.8	47.3	4004	2.0	14.0	24.0	38.0	-16.5	7.2	-9.3

9 Watt Loss Comparison

V1000					GA500					Difference		
Model	Carrier kHz	Watt Loss			Catalog Code	Carrier kHz	Watt Loss			Watt Loss		
CIMR-VU		Interior	External	Total	GA50U		Interior	External	Total	Interior	External	Total
4A0005	Swing 2 kHz	44.5	21.8	66.3	4005	2.0	16.0	32.0	48.0	-28.5	10.2	-18.3
4A0007	Swing 2 kHz	58.5	28.4	86.9	4007	2.0	20.0	44.0	64.0	-38.5	15.6	-22.9
4A0009	Swing 2 kHz	63.7	31.4	95.1	4009	2.0	28.0	58.0	86.0	-35.7	26.6	-9.1
4A0011	Swing 2 kHz	81.7	46.0	127.7	4012	2.0	39.0	83.0	122.0	-42.7	37.0	-5.7
4A0018	Swing 2 kHz	181.2	80.1	261.3	4018	2.0	52.0	155.0	207.0	-129.2	74.9	-54.3
4A0023	Swing 2 kHz	213.4	107.7	321.1	4023	2.0	86.0	236.0	322.0	-127.4	128.3	0.9
4A0031	Swing 2 kHz	287.5	146.1	433.6	4031	2.0	101.0	284.0	385.0	-186.5	137.9	-48.6
4A0038	Swing 2 kHz	319.2	155.8	475.0	4038	2.0	108.0	341.0	449.0	-211.2	185.2	-26.0
-	-	-	-	-	4044	2.0	137.0	417.0	554.0	N/A	N/A	N/A
-	-	-	-	-	4060	2.0	176.0	490.0	666.0	N/A	N/A	N/A

◆ Heavy Duty (Parameter C6-01=0)

Table 19 Single-Phase 240 V Models, Watt Loss Comparison

V1000					GA500					Difference		
Model	Carrier kHz	Watt Loss			Catalog Code	Carrier kHz	Watt Loss			Watt Loss		
CIMR-VU		Interior	External	Total	GA50U		Interior	External	Total	Interior	External	Total
BA0001	8.0	4.3	7.4	11.7	B001	10.0	8.0	5.0	13.0	3.7	-2.4	1.3
BA0002	8.0	7.9	8.9	16.7	B002	10.0	10.0	9.0	19.0	2.1	0.1	2.3
BA0003	8.0	16.1	11.5	27.7	B004	10.0	14.0	16.0	30.0	-2.1	4.5	2.3
BA0006	8.0	33.7	16.8	50.5	B006	10.0	18.0	28.0	46.0	-15.7	11.2	-4.5
BA0010	8.0	54.8	25.9	80.7	B010	8.0	31.0	42.0	73.0	-23.8	16.1	-7.7
BA0012	8.0	70.7	34.1	104.8	B012	8.0	41.0	55.0	96.0	-29.7	20.9	-8.8
BA0018	8.0	110.5	51.4	161.9	B018	8.0	53.0	98.0	151.0	-57.5	46.6	-10.9

Table 20 Three-Phase 240 V Models, Watt Loss Comparison

V1000					GA500					Difference		
Model	Carrier kHz	Watt Loss			Catalog Code	Carrier kHz	Watt Loss			Watt Loss		
CIMR-VU		Interior	External	Total	GA50U		Interior	External	Total	Interior	External	Total
2A0001	8.0	4.3	7.3	11.6	2001	10.0	6.0	5.0	11.0	1.7	-2.3	-0.6
2A0002	8.0	7.9	8.8	16.7	2002	10.0	7.0	8.0	15.0	-0.9	-0.8	-1.7
2A0004	8.0	16.2	11.5	27.7	2004	10.0	10.0	16.0	26.0	-6.2	4.5	-1.7
2A0006	8.0	27.4	15.9	43.3	2006	10.0	14.0	27.0	41.0	-13.4	11.1	-2.3
2A0010	8.0	54.8	23.8	78.6	2010	8.0	18.0	43.0	61.0	-36.8	19.2	-17.6
2A0012	8.0	70.7	29.9	100.6	2012	8.0	24.0	56.0	80.0	-46.7	26.1	-20.6
2A0020	8.0	110.5	43.3	153.8	2021	8.0	40.0	108.0	148.0	-70.5	64.7	-5.8
2A0030	8.0	231.5	72.2	303.7	2030	8.0	49.0	187.0	236.0	-182.5	114.8	-67.7
2A0040	8.0	339.5	82.8	321.3	2042	8.0	60.0	232.0	292.0	-279.5	149.2	-29.3
2A0056	8.0	347.6	117.6	465.2	2056	8.0	85.0	318.0	403.0	-262.6	200.4	-62.2
2A0069	8.0	437.7	151.4	589.1	2070	8.0	119.0	473.0	592.0	-318.7	321.6	2.9
-	-	-	-	-	2082	8.0	148.0	525.0	673.0	N/A	N/A	N/A

Table 21 Three-Phase 480 V Models, Watt Loss Comparison

V1000					GA500					Difference		
Model	Carrier kHz	Watt Loss			Catalog Code	Carrier kHz	Watt Loss			Watt Loss		
CIMR-VU		Interior	External	Total	GA50U		Interior	External	Total	Interior	External	Total
4A0001	8.0	19.2	11.5	30.7	4001	8.0	9.0	11.0	20.0	-10.2	-0.5	-10.7
4A0002	8.0	28.9	14.8	43.7	4002	8.0	11.0	16.0	27.0	-17.9	1.2	-16.7
4A0004	8.0	42.3	17.9	60.2	4004	8.0	15.0	31.0	46.0	-27.3	13.1	-14.2
4A0005	8.0	70.7	26.2	96.9	4005	8.0	18.0	42.0	60.0	-52.7	15.8	-36.9
4A0007	8.0	81.0	30.7	111.7	4007	8.0	18.0	49.0	67.0	-63.0	18.3	-44.7
4A0009	8.0	84.6	32.9	117.5	4009	8.0	25.0	65.0	90.0	-59.6	32.1	-27.5
4A0011	8.0	107.2	41.5	148.7	4012	8.0	32.0	85.0	117.0	-75.2	43.5	-31.7
4A0018	8.0	166.0	62.7	228.7	4018	8.0	55.0	166.0	221.0	-111.0	103.3	-7.7
4A0023	8.0	207.1	78.1	285.2	4023	8.0	61.0	200.0	261.0	-146.1	121.9	-24.2
4A0031	8.0	266.9	105.9	372.8	4031	8.0	79.0	255.0	334.0	-187.9	149.1	-38.8
4A0038	8.0	319.1	126.6	445.7	4038	8.0	95.0	338.0	433.0	-224.1	211.4	-12.7
-	-	-	-	-	4044	8.0	127.0	442.0	569.0	N/A	N/A	N/A
-	-	-	-	-	4060	8.0	135.0	446.0	581.0	N/A	N/A	N/A

10 Network Communication and Control I/O Options

V1000 network communication and I/O options are generally compatible with GA500. Firmware inside these options may require an update to support GA500. Refer to the “Applicable Products” section of the specific Option Installation Manual on www.yaskawa.com to get the compatible firmware version required in the option card.

Navigate to the “Options” section of the GA500 product page for more information on GA500 compatible options.

URL: <https://www.yaskawa.com/products/drives/industrial-ac-drives/microdrives/ga500-drive>

Home / Products / Drives / Industrial AC Drives / Microdrives / GA500 Drive

GA500 Drive Print



1/8 – 40 HP
The GA500 industrial AC micro drive combines simplicity and flexibility with Yaskawa's tradition of highly reliable products. Out of the box, the GA500 is a breeze to install with minimal wire preparation needed. Programming is simple enough to get the motor spinning in minutes but powerful enough to solve many of the toughest applications with tried and true open loop vector and V/f control.

Video | Flyer | Brochure | Tech Manual | Quick Start Guide | Core Manuals

Overview | **Options** | Software | Support & Training | Documents | Drawings

Features

Highlights

- ▶ No power pro Power
- ▶ Responsive I Enclosures
- ▶ Conformal coated (IEC 60721-3-3, 3C2, 3S2)

Products

- Drives
- Industrial AC Drives
- General Purpose Drives
- Microdrives
- GA500 Drive
- V1000 Drive
- V1000-4X Drive
- J1000 Drive
- Fan & Pump Drives
- System Components
- Industrial Network

Refer to the GA500 Selection Guide No. SL.GA500.01 for a complete list of GA500 options.

Download here: <https://www.yaskawa.com/sl.ga500.01>



11 Other Option Compatibility

Use this section to understand the compatibility of other V1000 options for the GA500.

Navigate to the “Options” section of the GA500 product page for more information on GA500 compatible options.

URL: <https://www.yaskawa.com/products/drives/industrial-ac-drives/microdrives/ga500-drive>

- **Braking resistor option (LKEB):** The braking unit can be transferred to GA500 without making any changes.
- **Braking units (CDBR Type):**
The braking unit can be transferred to GA500 without making any changes. If using a CDBR braking unit, set L8-55 = 0 [Internal DB Transistor Protection = Disabled].
- **AC or DC reactor:**
The AC or DC reactor can be transferred to GA500 without making any changes.

Refer to the GA500 Selection Guide No. SL.GA500.01 for a complete list of GA500 options.

Download here: <https://www.yaskawa.com/sl.ga500.01>

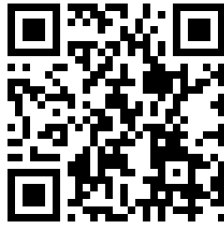

V1000 to GA500

Product Transition Guide

YASKAWA AMERICA, INC.

2121, Norman Drive South,
Waukegan, IL 60085, U.S.A.
+1-800-YASKAWA (927-5292)
<http://www.yaskawa.com>

Specifications are subject to change without notice for ongoing product modifications and improvements.
© 2020–2021 YASKAWA America, Inc.

PL.GA500.01
Revision: B <0>-0
March 2021
Published in U.S.A.

YASKAWA