

# TK Series

## High function/High performance PID control

NEW

### ■ Features

- Super high-speed sampling cycle (10 times faster compared to existing models)  
: 50ms sampling cycle and  $\pm 0.3\%$  display-accuracy.
- Improved visibility with wide display part and high luminance LED
- High performance controlling with heating/cooling control and automatic/manual control modes
- Communication function supported  
: RS485 (Modbus RTU)
- Allows parameter setting and monitoring by USB port of PC  
: only for using DAQMaster or USB to Serial converter (SCM-US, sold separately)
- SSR output/Current output selectable
- SSRP output (standard/phase/cycle control selectable)
- Heater burn-out alarm (C.T input) (except TK4SP)  
(※CT, purchase separately)
- Multi SV setting function (Max. 4) – selectable via digital input terminals
- Mounting space saving with compact design  
: downsized by approx. 38% (60mm) in depth compared to existing models
- Multi input / Multi range



 Please read "Caution for your safety" in operation manual before using.



(To be certified soon)

### ■ User manual

- Visit our web site ([www.autonics.com](http://www.autonics.com)) to download user manual and communication manual.
- User manual describes for specifications and function, and communication manual describes for RS485 communication (Modbus RTU protocol) and parameter address map data.

### ■ Integrated device management program(DAQMaster)

- DAQMaster is a integrated device management program for Autonics TK series providing GUI control for easy and convenient management of parameters and multiple device data monitoring.
- Visit our website ([www.autonics.com](http://www.autonics.com)) to download user manual and integrated device management program.

< Computer specification for using software >

Item	Recommended specification
Processor	IBM PC compatible computer with Intel Pentium III or above
Operating system	Windows 98 / NT / XP / Vista / 7
RAM	Over 256MB
Hard disk	Over 1GB of available space
VGA	Over 1024×768
Others	RS232 serial port, USB port

< DAQMaster screen >



Wiki  
LZonline  
[laleharonline.com/wiki](http://laleharonline.com/wiki)





# TK Series

## Specifications

Series		TK4S	TK4SP	TK4M	TK4W	TK4H	TK4L
Control output	Relay	250VAC 3A 1a					
	SSR	11VDC±2V 20mA Max.					
	Current	DC4-20mA or DC0-20mA (Load 500Ω Max.)					
Sub output	Relay	AL1, AL2 relay : 250VAC 3A 1a(TK4SP : AL1 only)					
	Transmission	DC4-20mA (Load 500Ω Max., Accuracy : ±0.3% F · S)					
	Communication	RS485 communication output (Modbus RTU)					
Option input	CT	0.0-50.0A (Primary heater current value measuring range) ※CT ratio = 1000:1 (Except TK4SP)					
	Digital input	<ul style="list-style-type: none"> <li>• Contact Input: ON-Max. 2kΩ, OFF-Min. 90kΩ</li> <li>• Non-contact Input: ON-Residual voltage max. 1.0V, OFF-leakage current max. 0.1mA</li> <li>• Outflow current : Approx. 0.5mA</li> <li>※ TK4S/M-1EA (Due to limited terminals), TK4H/W/L-2EA (Except TK4SP)</li> </ul>					
Control type	Heating, cooling Heating&cooling	ON/OFF, P, PI, PD, PID control mode					
Hysteresis		• Thermocouples / RTD : 1 to 100°C/°F (0.1 to 100.0°C/°F) variable • Analog : 1 to 100 Digit					
Proportional band (P)		0.1 to 999.9% (0.1 to 999.9%)					
Integral time (I)		0 to 9999 sec.					
Derivative time (D)		0 to 9999 sec.					
Control period (T)		0.1 to 120.0 sec. (※Relay output and SSR drive output only)					
Manual reset value		0.0 to 100.0%					
Sampling period		50ms					
Dielectric strength		2000VAC 50/60Hz for 1min. (between power source terminal and input terminal)					
Vibration resistance		0.75mm amplitude at frequency of 5 to 55Hz (for 1min.) in each X, Y, Z direction for 2 hours					
Relay life cycle	Mechanical	OUT1/2: Min. 5,000,000 times, AL1/2: Min. 20,000,000 times (TK4H/W/L: Min. 5,000,000 times)					
	Electrical	OUT1/2: Min. 200,000 times, AL1/2: Min. 100,000 times (TK4H/W/L: Min. 200,000 times)					
Insulation resistance		Min. 100MΩ (500VDC megger)					
Noise resistance		Square shaped noise by noise simulator (pulse width 1μs) ±2kV R-phase, S-phase					
Memory retention		Approx. 10years (When using non-volatile semiconductor memory type)					
Ambient temperature		-10 to 50°C (at non-freezing status)					
Storage temperature		-20 to 60°C (at non-freezing status)					
Ambient humidity		35 to 85%RH (at non-dew status)					
Protection		IP65 (Front panel) ※TK4SP: IP50 (Front panel)					
Insulation type		(★2)		□			
Unit weight		Approx. 105g	Approx. 85g	Approx. 140g	Approx. 141g	Approx. 141g	Approx. 198g

※(★2) "□" Mark indicated that equipment protected throughout by double insulation or reinforced insulation.

## Connections

※Please check the polarity when connecting temperature sensor or analog input.

### TK4S

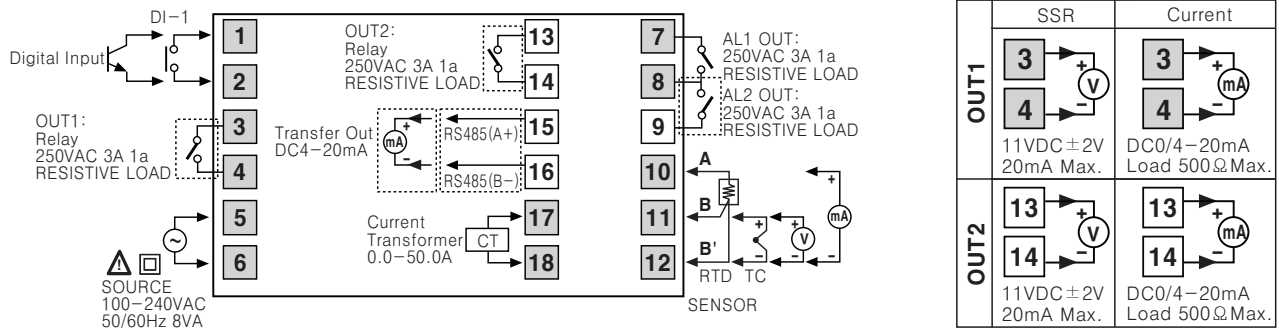

# High Function/High Performance PID Control

## ■ Connections

※Please check the polarity when connecting temperature sensor or analog input.

### ●TK4SP

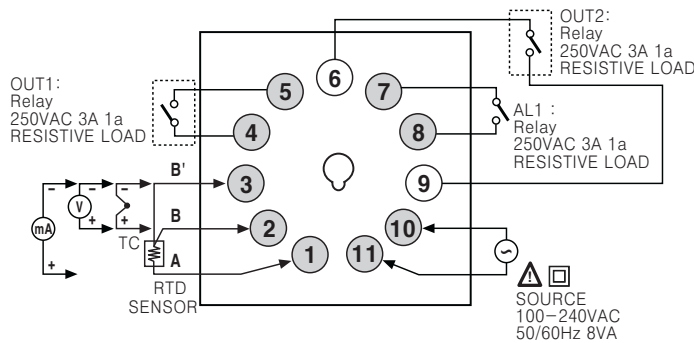

	SSR	Current
OUT1	5 → + 4 → - 11VDC ±2V 20mA Max.	5 → + 4 → - DC0/4-20mA Load 500Ω Max.
	9 → + 6 → - 11VDC ±2V 20mA Max.	9 → + 6 → - DC0/4-20mA Load 500Ω Max.

### ●TK4M

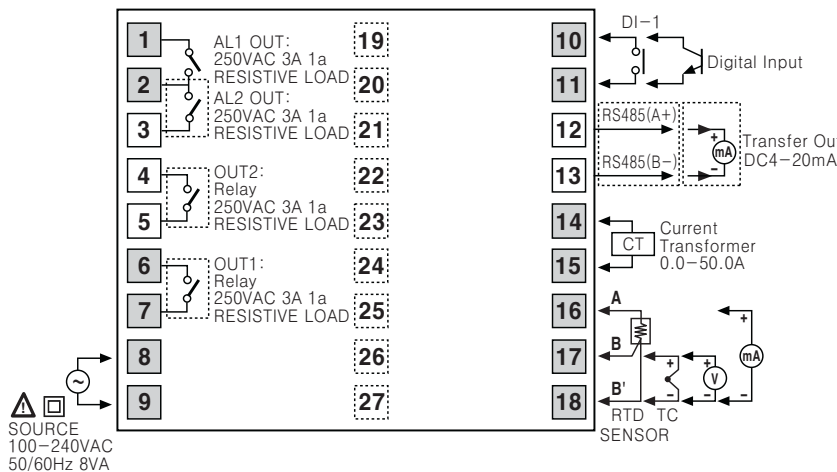

	SSR	Current
OUT1	6 → + 7 → - 11VDC ±2V 20mA Max.	6 → + 7 → - DC0/4-20mA Load 500Ω Max.
	4 → + 5 → - 11VDC ±2V 20mA Max.	4 → + 5 → - DC0/4-20mA Load 500Ω Max.

### ●TK4H / TK4W / TK4L

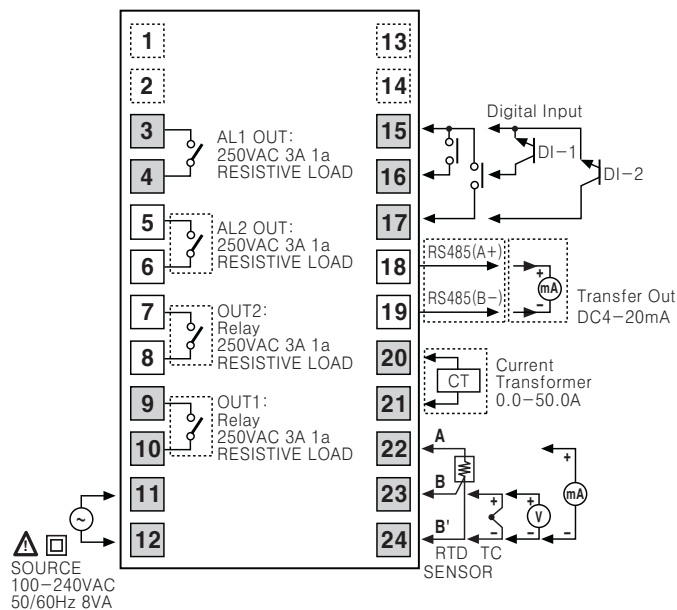

	SSR	Current
OUT1	9 → + 10 → - 11VDC ±2V 20mA Max.	9 → + 10 → - DC0/4-20mA Load 500Ω Max.
	7 → + 8 → - 11VDC ±2V 20mA Max.	7 → + 8 → - DC0/4-20mA Load 500Ω Max.

※Digital input is not electrically insulated from internal circuits, so it should be insulated when connecting other circuits. (Photocoupler, Relay, Independent switch)

- (A) Photo electric sensor
- (B) Fiber optic sensor
- (C) Door/Area sensor
- (D) Proximity sensor
- (E) Pressure sensor
- (F) Rotary encoder
- (G) Connector/Socket
- (H) Temp. controller
- (I) SSR/Power controller
- (J) Counter
- (K) Timer
- (L) Panel meter
- (M) Tacho/Speed/Pulse meter
- (N) Display unit
- (O) Sensor controller
- (P) Switching power supply
- (Q) Stepping motor & Driver & Controller
- (R) Graphic/Logic panel
- (S) Field network device
- (T) Production stoppage models & replacement

# TK Series

## ■ Dimensions

### ●TK4S

●Bracket

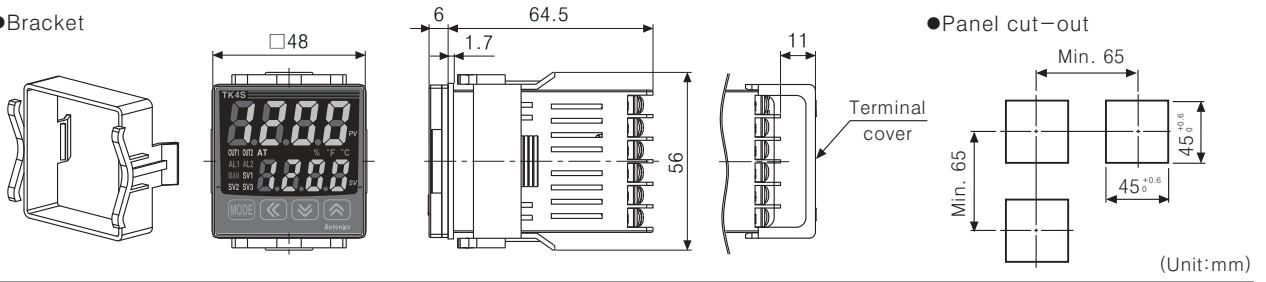

### ●TK4SP

●Bracket

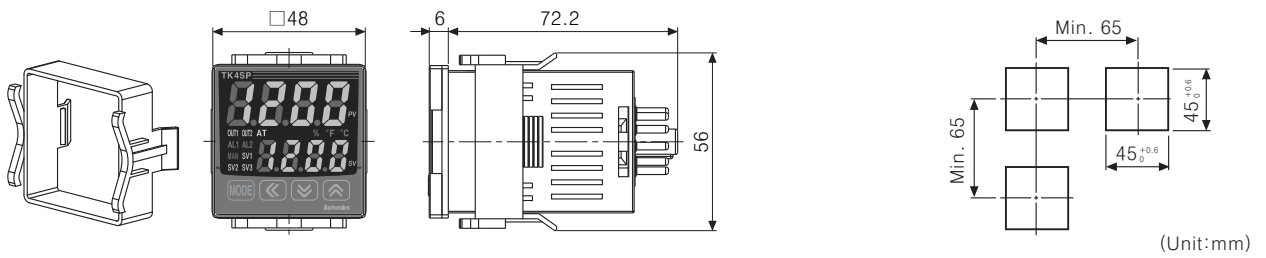

### ●TK4M

●Bracket

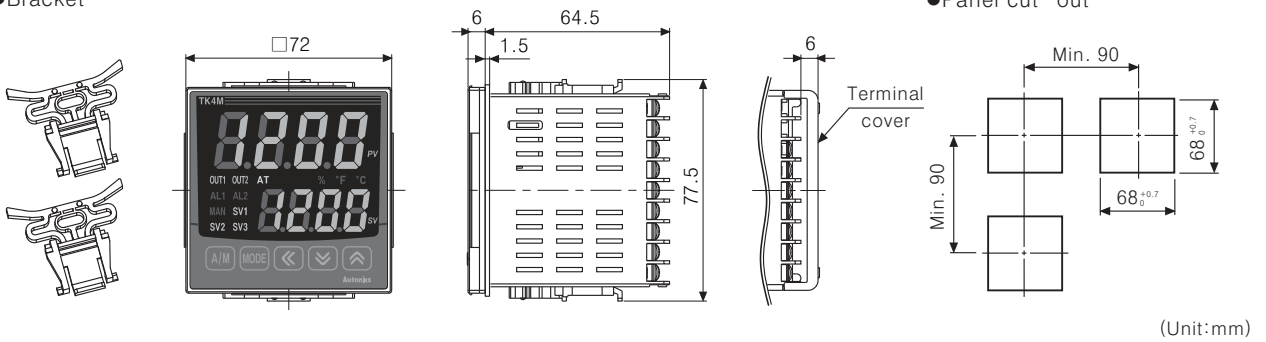

### ●TK4H

●Bracket

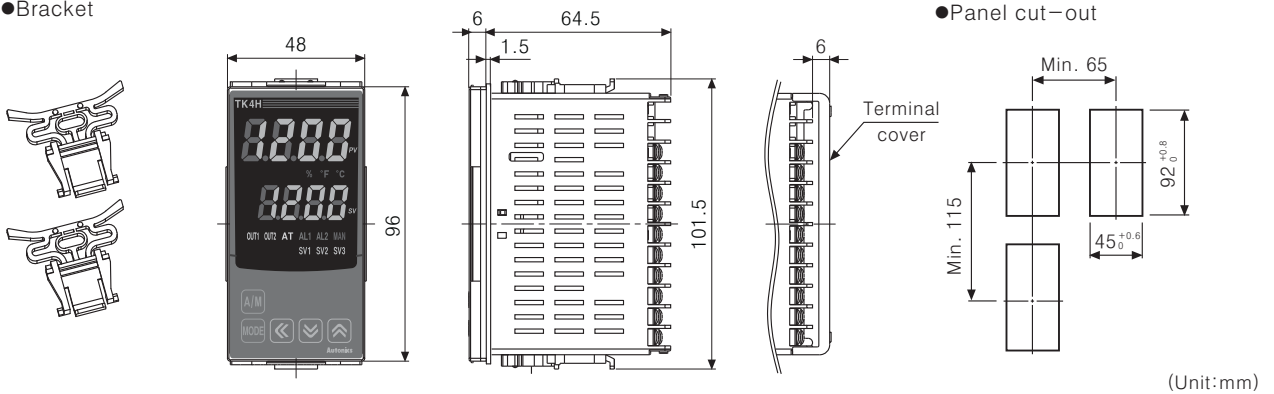

### ●TK4W

●Bracket

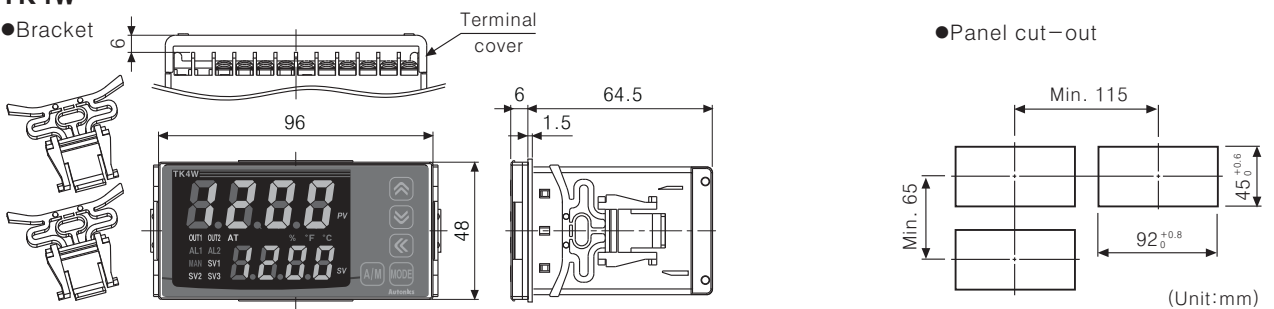

# High Function/High Performance PID Control

## ●TK4L

- Bracket

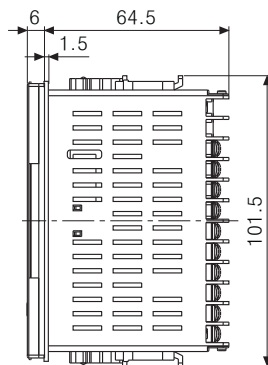
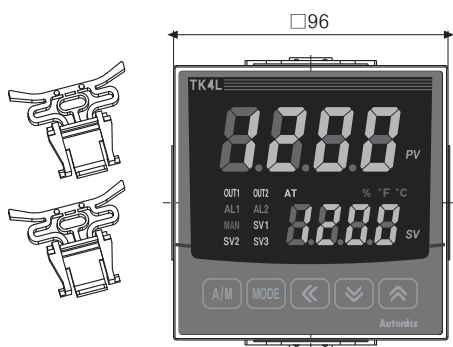

- Panel cut-out

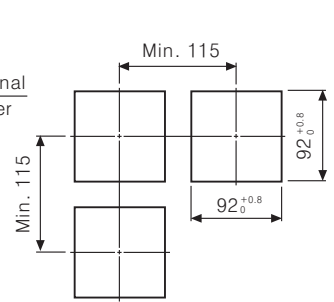

(Unit:mm)

## ●Terminal cover(Sold separately)

- RSA-Cover (48×48mm size)

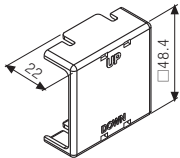

- RMA-Cover (72×72mm size)

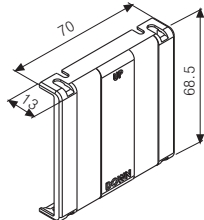

- RHA-Cover (48×96mm, 96×48mm size)

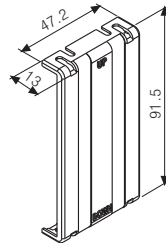

- RLA-Cover (96×96mm size)

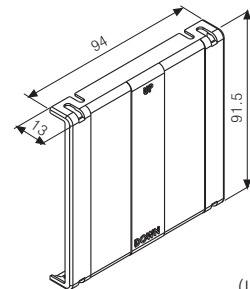

(Unit:mm)

## ■Product mounting

- TK4S/SP(48×48mm) series

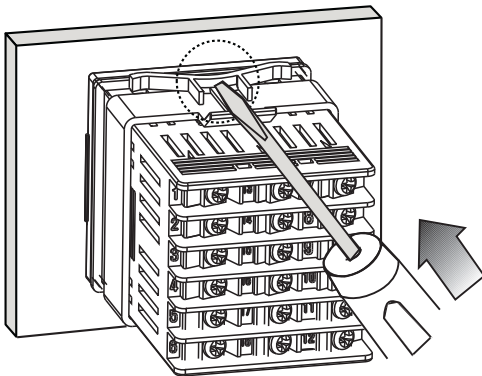

- Other series

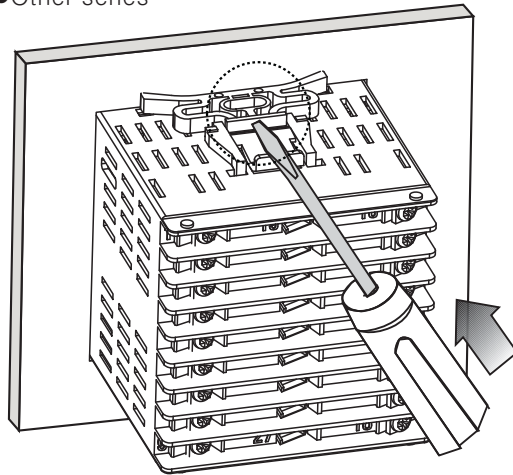

※Insert product into a panel, fasten bracket by pushing with tools as shown above.

(A)	Photo electric sensor
(B)	Fiber optic sensor
(C)	Door/Area sensor
(D)	Proximity sensor
(E)	Pressure sensor
(F)	Rotary encoder
(G)	Connector/Socket
(H)	Temp. controller
(I)	SSR/Power controller
(J)	Counter
(K)	Timer
(L)	Panel meter
(M)	Tacho/Speed/Pulse meter
(N)	Display unit
(O)	Sensor controller
(P)	Switching power supply
(Q)	Stepping motor & Driver & Controller
(R)	Graphic/Logic panel
(S)	Field network device
(T)	Production stoppage models & replacement



# High Function/High Performance PID Control

## Parts description

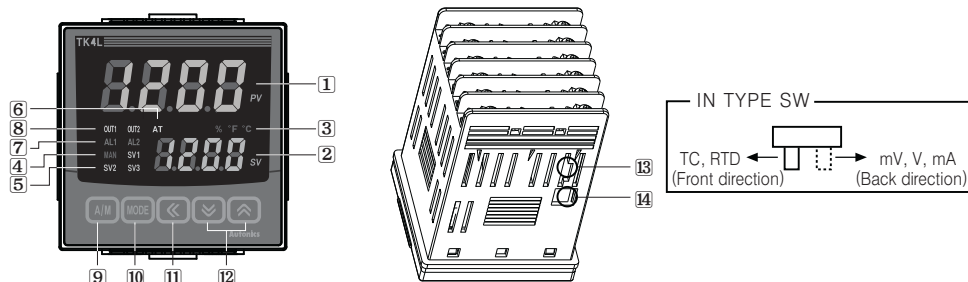

- 1 PV display part : It shows current temperature (PV) in RUN mode and parameters in Setting mode.
- 2 SV display part : It shows setting temperature value (SV) to control in RUN mode and each parameter setting value in Setting mode.
- 3 Unit(°C / °F / %) Indicator : It shows PV unit.
- 4 Manual control indicator : It will be ON in case of selecting manual control mode.
- 5 Multi SV indicator : One of SV1 to 3 lamp will be ON in case of selecting multi SV function.
- 6 Auto-Tuning indicator : It will be flashing every 1 sec during Auto-tuning.
- 7 Alarm output indicator : It will be ON when each alarm output is ON.
- 8 Control output(Heating, Cooling) Indicator : It will be ON when control output is ON.  
 \*In case that SSRP output type is control/phase mode, it will be ON when MV is over 3.0%.  
 \*In case of selecting current output (4-20mA DC, 0-20mA DC),  
 - Manual control mode: It will be always ON except MV is 0.0%.  
 - Auto control mode: It will be ON when MV is over 3.0%, and OFF when MV is below 2.0%.
- 9 **A/M** key : Used when switching auto control mode ↔ manual control mode  
 \* In case of TK4S/SP model(W48×H48mm), **MODE** key will be used for the same function (auto control mode ↔ manual control mode switching).
- 10 **MODE** key : Used when entering into parameter setting mode and moving parameters.
- 11 **←** key : Used when entering into set value change mode and Digit moving.
- 12 **→** key : Used when entering into set value change mode and changing set value(Digit).
- 13 Input selection switch : Used when switching sensor(TC, RTD) input ↔ analog input(mV, V, mA).
- 14 PC loader port : It is serial communication PC loader port for PC parameter setting and monitoring used when connecting dedicated USB to Serial converter(SCM-US).

## Flow chart for SV setting

- 1 Press any key among **←**, **→**, **↔** in RUN mode to enter into SV setting mode. Last DIGIT(10<sup>0</sup> DIGIT) on SV display part will be flashing.
- 2 Press **←** key to move DIGIT. (10<sup>0</sup>→10<sup>1</sup>→10<sup>2</sup>→10<sup>3</sup>→10<sup>0</sup>)
- 3 Set the number 0↔1↔2↔3↔4↔5 ↔6↔7↔8↔9↔0 for each digit with **→**, **↔** key and set the SV using **←**, **→**, **↔** keys.
- 4 Press **MODE** key to save the setting value. If there is no additional key operations in 3 sec., changed SV will be automatically saved.

(A)	Photo electric sensor
(B)	Fiber optic sensor
(C)	Door/Area sensor
(D)	Proximity sensor
(E)	Pressure sensor
(F)	Rotary encoder
(G)	Connector/Socket
(H)	Temp. controller
(I)	SSR/Power controller
(J)	Counter
(K)	Timer
(L)	Panel meter
(M)	Tacho/Speed/Pulse meter
(N)	Display unit
(O)	Sensor controller
(P)	Switching power supply
(Q)	Stepping motor & Driver & Controller
(R)	Graphic/Logic panel
(S)	Field network device
(T)	Production stoppage models & replacement

# TK Series

## Flow chart for setting group

※Set Parameter group 3 [PAR-3] → Set Parameter group 4 [PAR-4] → Set Parameter group 5 [PAR-5] → Set Parameter group 2 [PAR-2] → Set Parameter group 1 [PAR-1] → Set SV group [SV] in order.

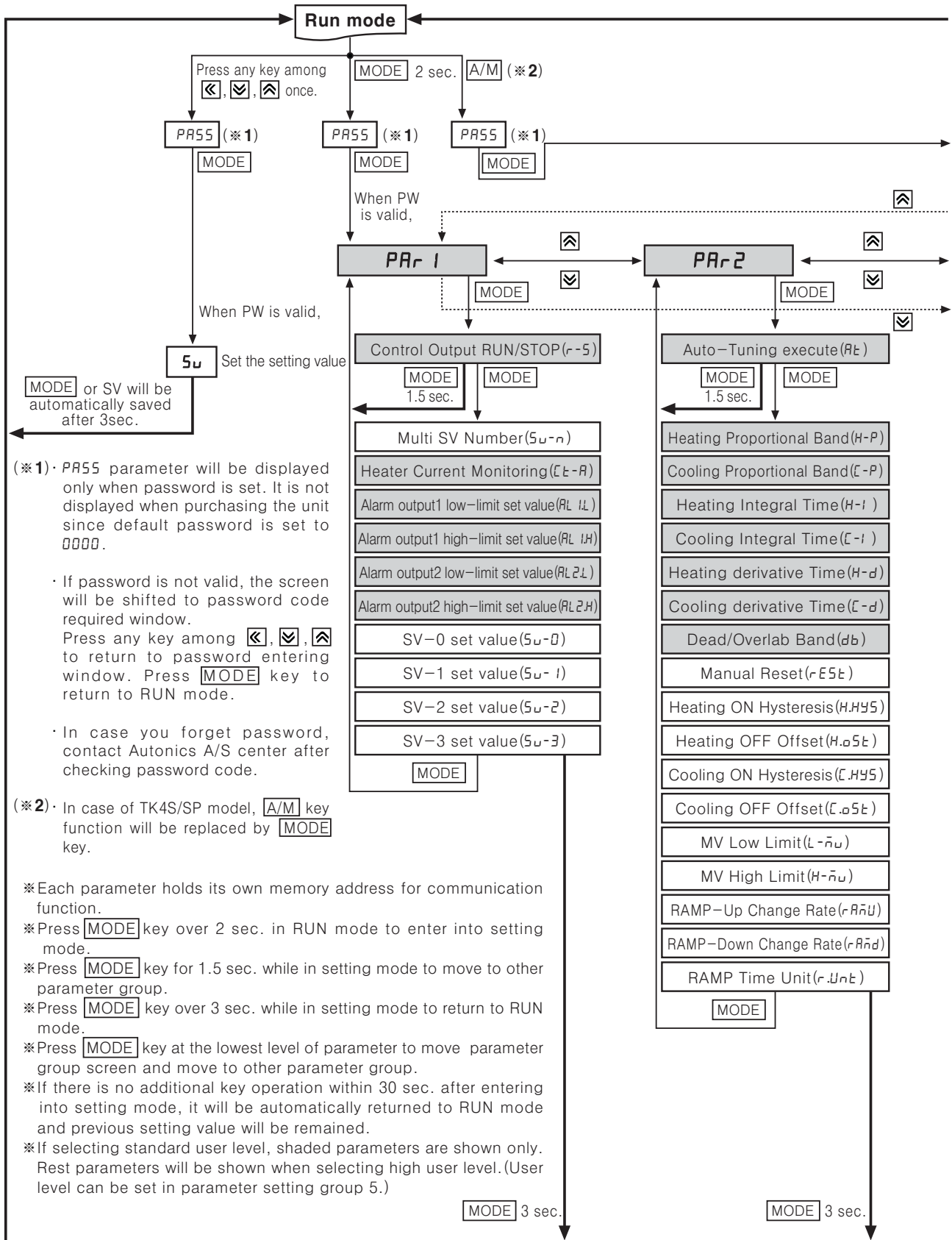

- (※1) · PASS parameter will be displayed only when password is set. It is not displayed when purchasing the unit since default password is set to 0000.
- If password is not valid, the screen will be shifted to password code required window. Press any key among  $\leftarrow$ ,  $\downarrow$ ,  $\uparrow$  to return to password entering window. Press **MODE** key to return to RUN mode.
- In case you forget password, contact Autonics A/S center after checking password code.
- (※2) · In case of TK4S/SP model, **A/M** key function will be replaced by **MODE** key.

- ※ Each parameter holds its own memory address for communication function.
- ※ Press **MODE** key over 2 sec. in RUN mode to enter into setting mode.
- ※ Press **MODE** key for 1.5 sec. while in setting mode to move to other parameter group.
- ※ Press **MODE** key over 3 sec. while in setting mode to return to RUN mode.
- ※ Press **MODE** key at the lowest level of parameter to move parameter group screen and move to other parameter group.
- ※ If there is no additional key operation within 30 sec. after entering into setting mode, it will be automatically returned to RUN mode and previous setting value will be remained.
- ※ If selecting standard user level, shaded parameters are shown only. Rest parameters will be shown when selecting high user level. (User level can be set in parameter setting group 5.)

# High Function/High Performance PID Control

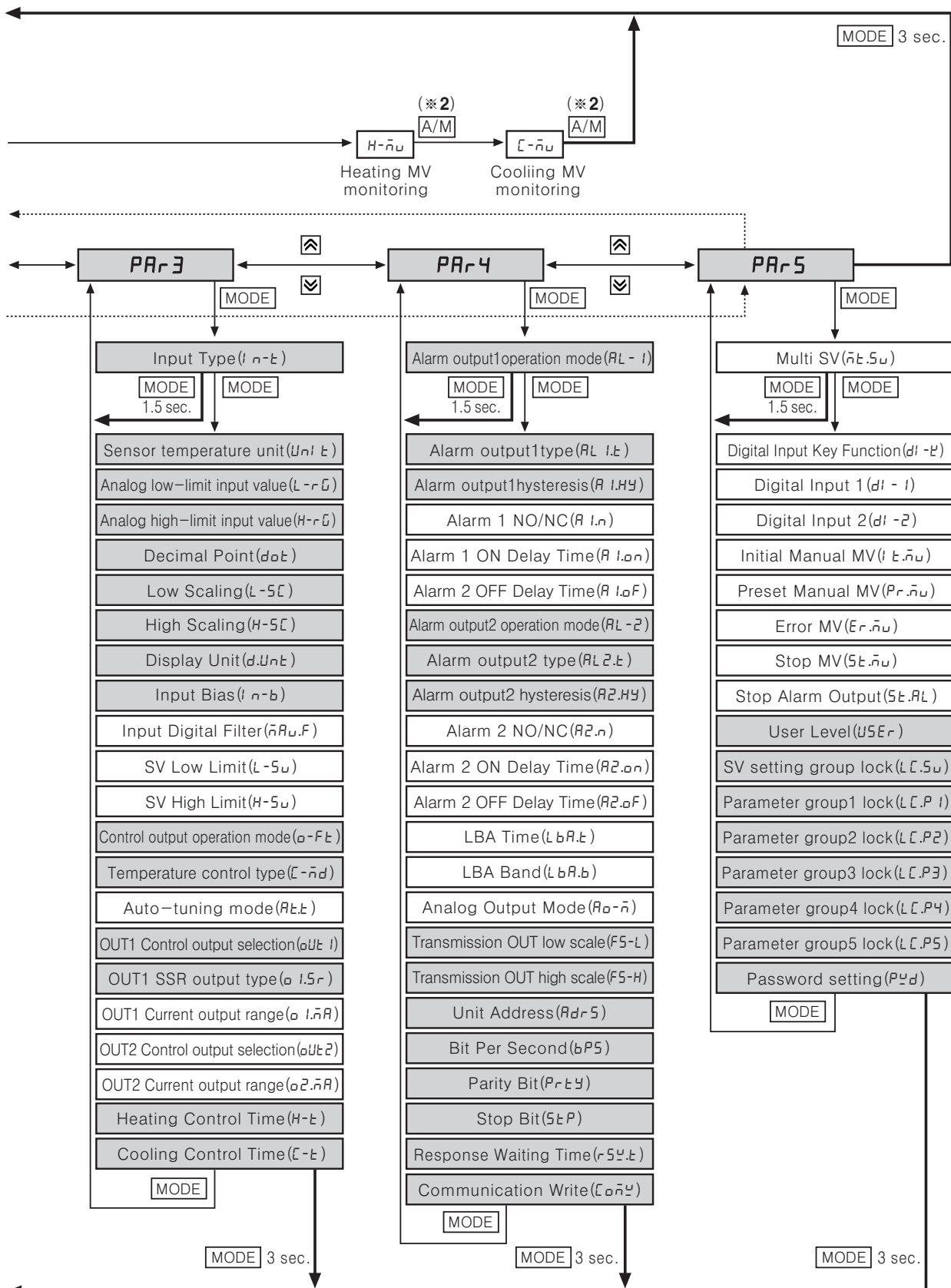

- (A) Photo electric sensor
- (B) Fiber optic sensor
- (C) Door/Area sensor
- (D) Proximity sensor
- (E) Pressure sensor
- (F) Rotary encoder
- (G) Connector/Socket
- (H) Temp. controller
- (I) SSR/Power controller
- (J) Counter
- (K) Timer
- (L) Panel meter
- (M) Tacho/Speed/Pulse meter
- (N) Display unit
- (O) Sensor controller
- (P) Switching power supply
- (Q) Stepping motor & Driver & Controller
- (R) Graphic/Logic panel
- (S) Field network device
- (T) Production stoppage models & replacement

# TK Series

## Flow chart for setting group 1

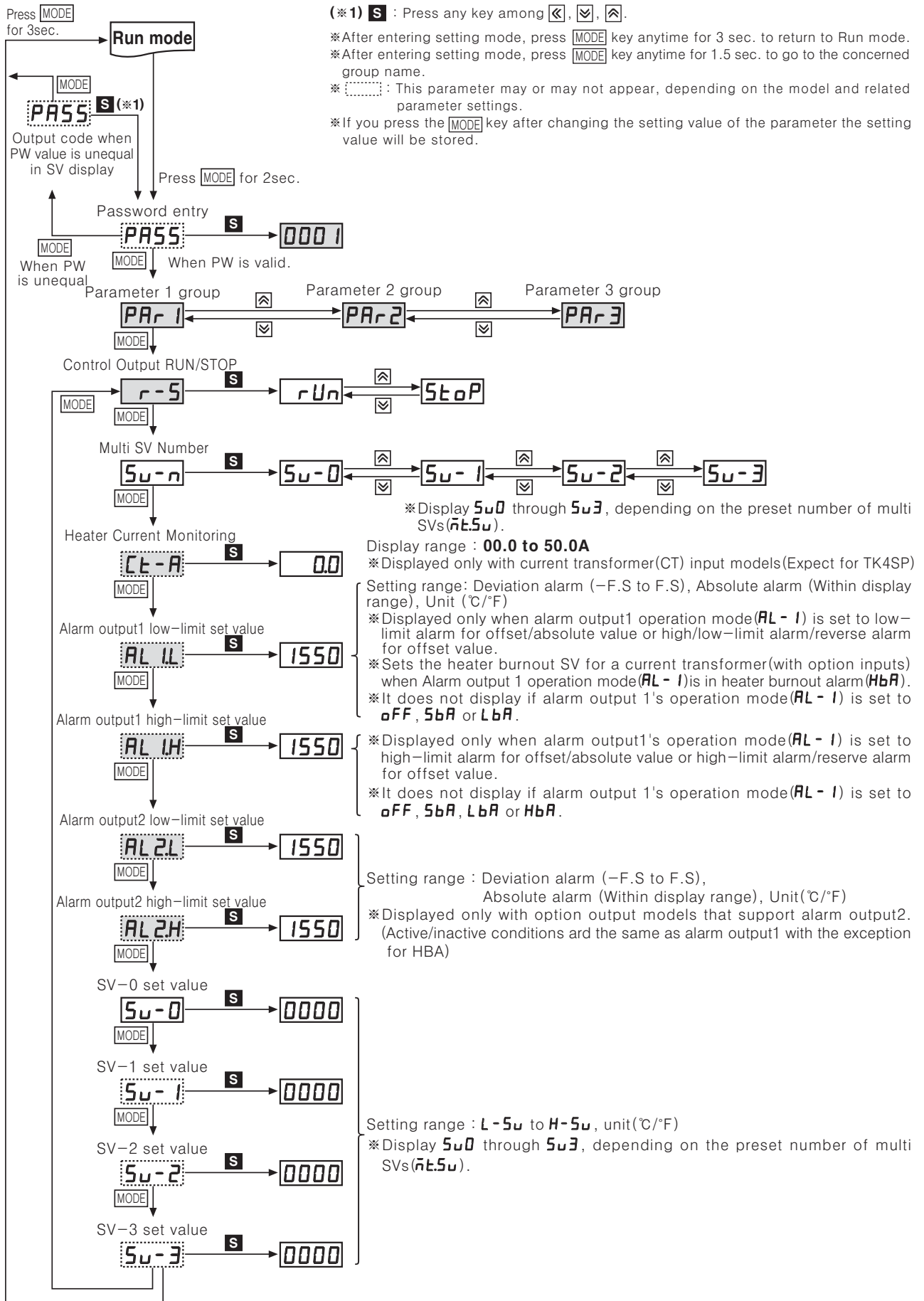

# High Function/High Performance PID Control

## Flow chart for setting group 2

(※1) **S** : Press any key among  $\leftarrow$ ,  $\rightarrow$ ,  $\uparrow$ ,  $\downarrow$ .

※After entering setting mode, press **MODE** key anytime for 3 sec. to return to Run mode.

※After entering setting mode, press **MODE** key anytime for 1.5 sec. to go to the concerned group name.

※ $\square$ : This parameter may or may not appear, depending on the model and related parameter settings.

※If you press the **MODE** key after changing the setting value of the parameter the setting value will be stored.

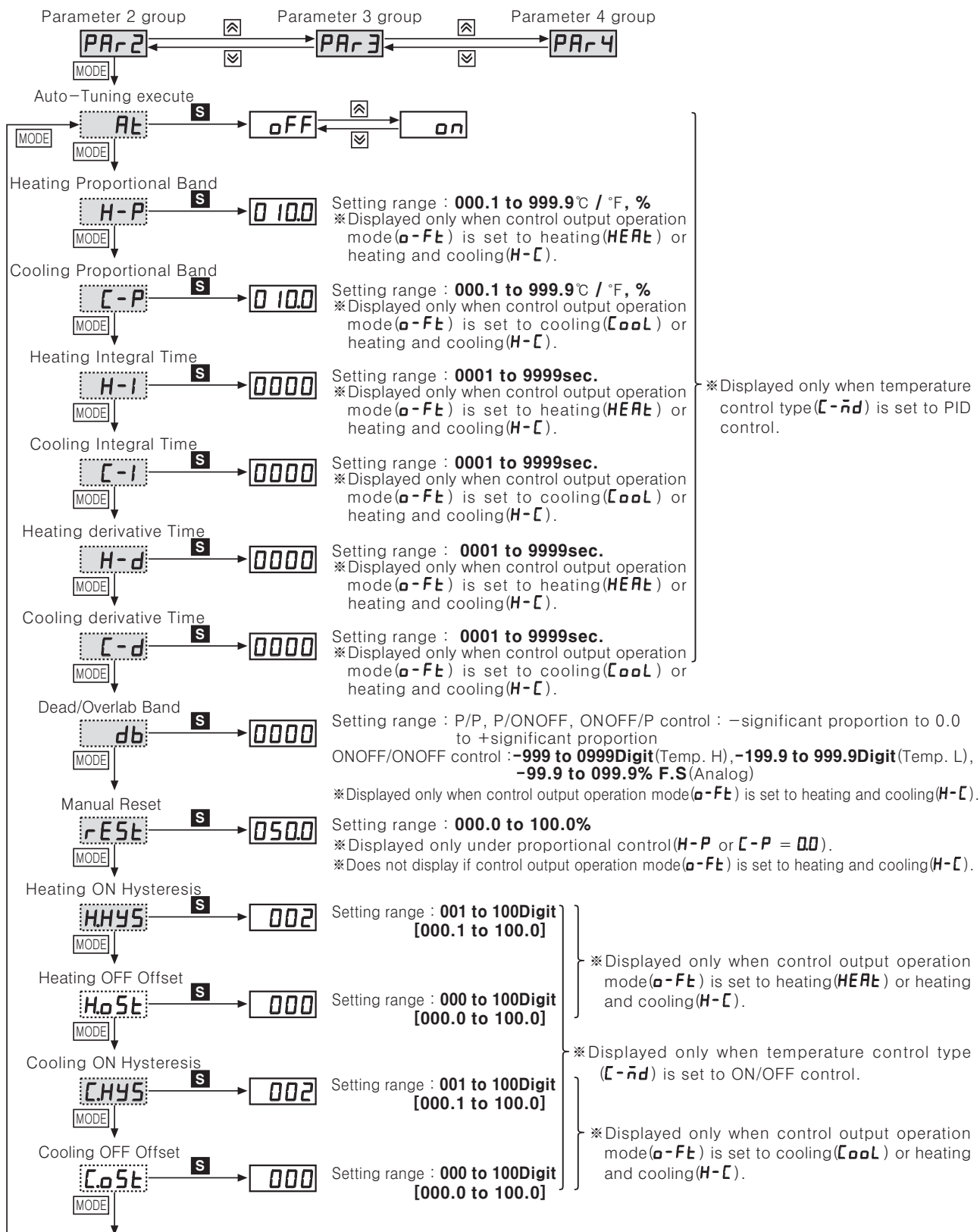

- (A) Photo electric sensor
- (B) Fiber optic sensor
- (C) Door/Area sensor
- (D) Proximity sensor
- (E) Pressure sensor
- (F) Rotary encoder
- (G) Connector/Socket
- (H) Temp. controller
- (I) SSR/Power controller
- (J) Counter
- (K) Timer
- (L) Panel meter
- (M) Tacho/Speed/Pulse meter
- (N) Display unit
- (O) Sensor controller
- (P) Switching power supply
- (Q) Stepping motor & Driver & Controller
- (R) Graphic/Logic panel
- (S) Field network device
- (T) Production stoppage models & replacement



# High Function/High Performance PID Control

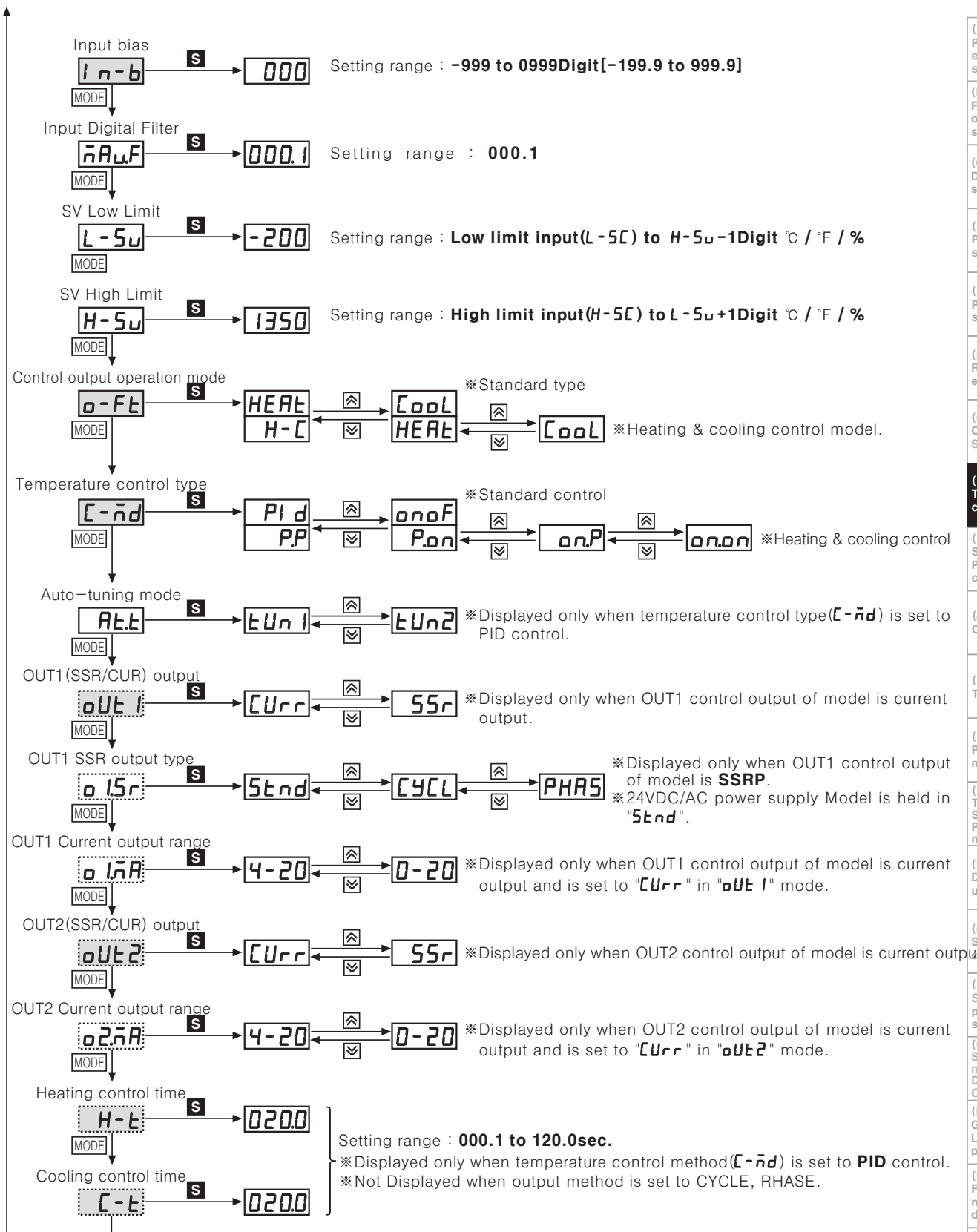

\*OUT1, OUT2 output :

- ① In case that OUT1,OUT2 output is relay output type , oUt 1, o1Sr, o1nA, oUt2, o2Sr, o2nA parameter are not displayed.
- ② In case that OUT1,OUT2 output is SUR + SSR output type, when OUT1,OUT2 output is set to SSR . output method of o1Sr, o2Sr is held in Stnd and parameter is not displayed.
- ③ In case that OUT1, output is SSRP output type and OUT2 output is SUR + SSR
  - oUt 1, o1nA are not displayed.
  - o1Sr can set to Stnd, CYCL, PHAS.
  - When o2Sr is set to SSR it is held in Stnd and parameter is not displayed.

(A)	Photo electric sensor
(B)	Fiber optic sensor
(C)	Door/Area sensor
(D)	Proximity sensor
(E)	Pressure sensor
(F)	Rotary encoder
(G)	Connector/Socket
(H)	Temp. controller
(I)	SSR/Power controller
(J)	Counter
(K)	Timer
(L)	Panel meter
(M)	Tacho/Speed/Pulse meter
(N)	Display unit
(O)	Sensor controller
(P)	Switching power supply
(Q)	Stepping motor & Driver & Controller
(R)	Graphic/Logic panel
(S)	Field network device
(T)	Production stoppage models & replacement

# TK Series

## Flow chart for setting group 4

(※1) **S** : Press any key among  $\leftarrow$ ,  $\downarrow$ ,  $\rightarrow$ .

※After entering setting mode, press **MODE** key anytime for 3 sec. to return to Run mode.

※After entering setting mode, press **MODE** key anytime for 1.5 sec. to go to the concerned group name.

※ $\square$ : This parameter may or may not appear, depending on the model and related parameter settings.

※If you press the **MODE** key after changing the setting value of the parameter the setting value will be stored.

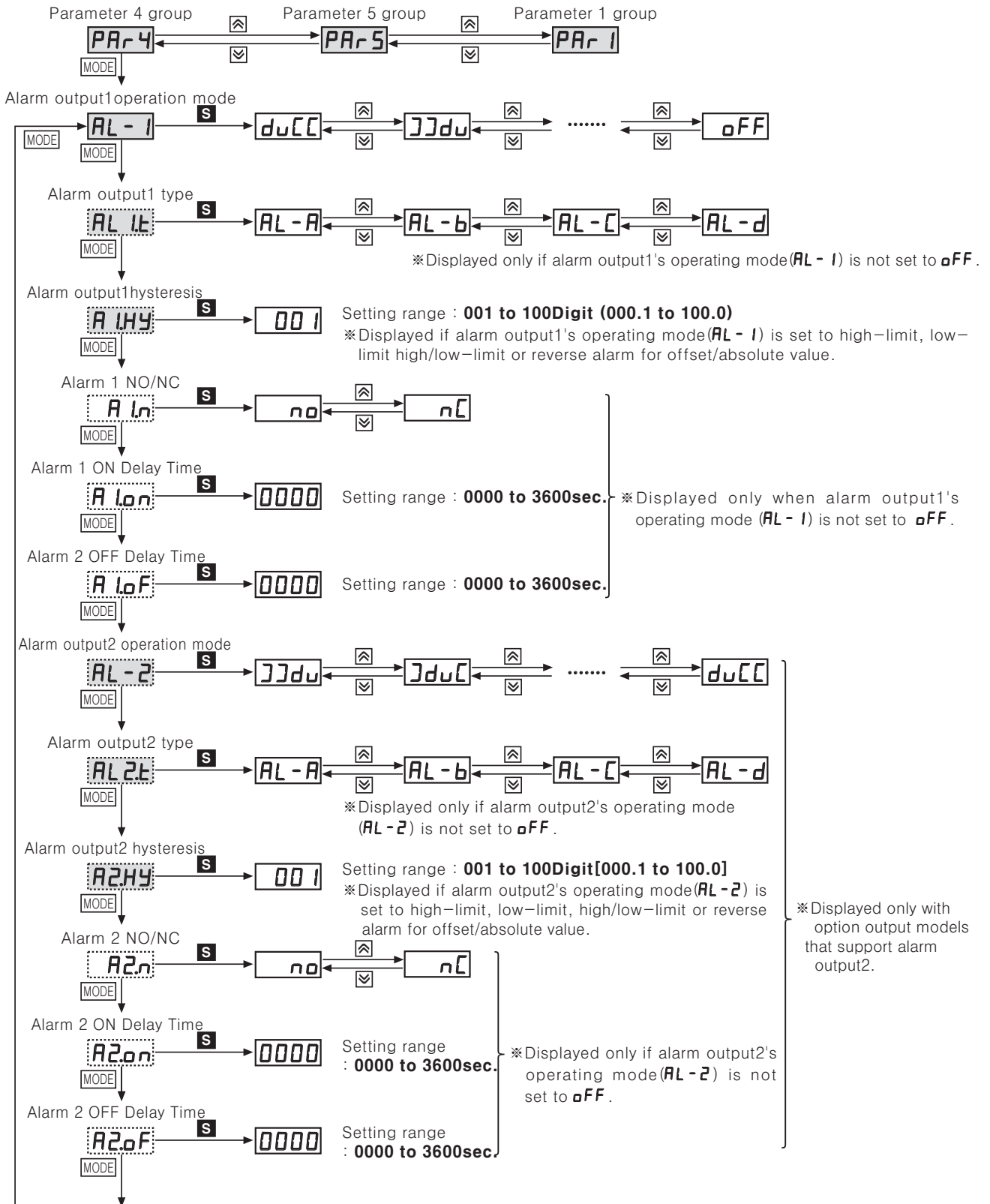

# High Function/High Performance PID Control

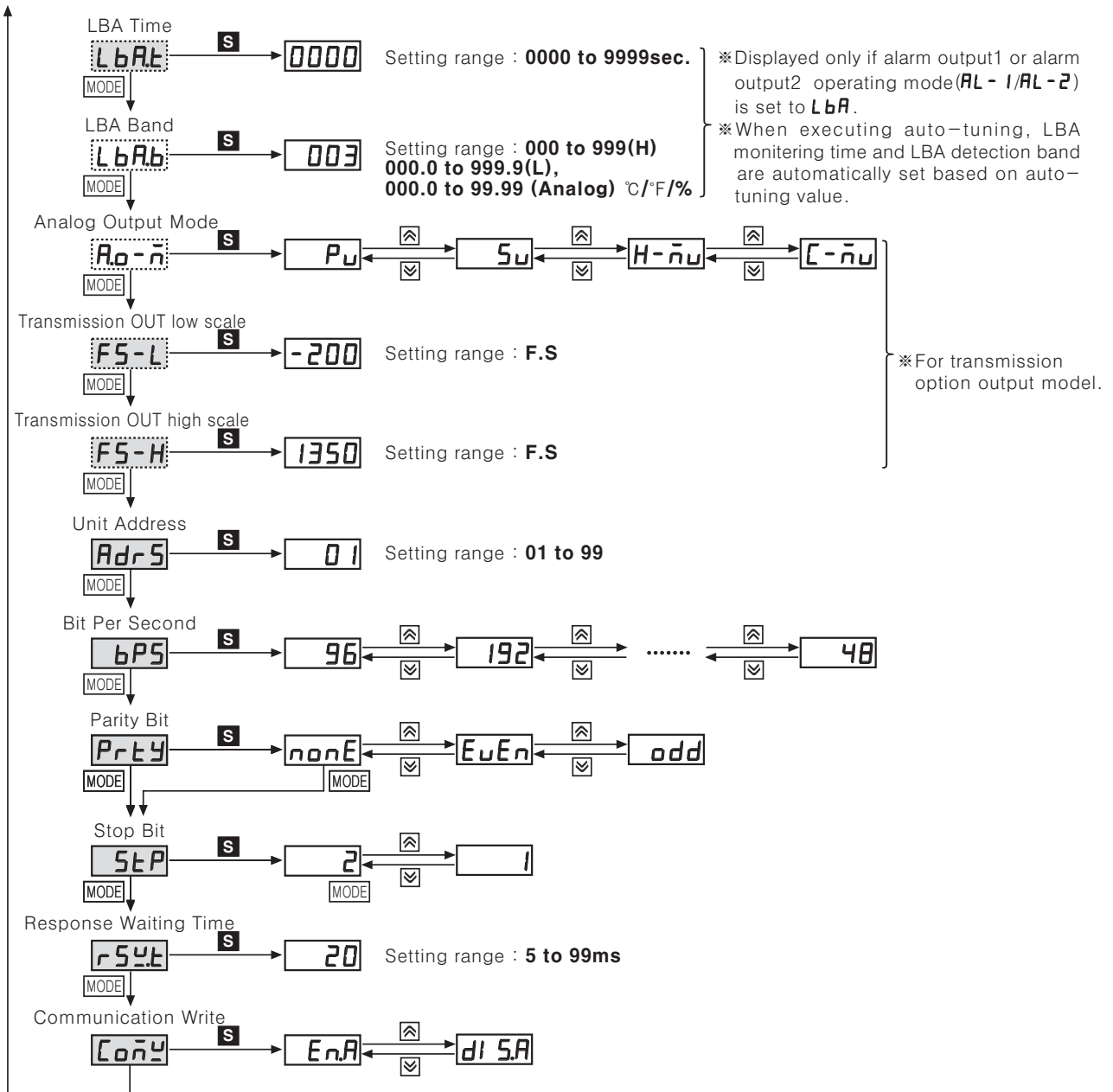

- (A) Photo electric sensor
- (B) Fiber optic sensor
- (C) Door/Area sensor
- (D) Proximity sensor
- (E) Pressure sensor
- (F) Rotary encoder
- (G) Connector/Socket
- (H) Temp. controller
- (I) SSR/Power controller
- (J) Counter
- (K) Timer
- (L) Panel meter
- (M) Tacho/Speed/Pulse meter
- (N) Display unit
- (O) Sensor controller
- (P) Switching power supply
- (Q) Stepping motor & Driver & Controller
- (R) Graphic/Logic panel
- (S) Field network device
- (T) Production stoppage models & replacement

## Flow chart for setting group 5

(※1) **S** : Press any key among **◀**, **▶**, **↵**.

※After entering setting mode, press **MODE** key anytime for 3 sec. to return to Run mode.

※After entering setting mode, press **MODE** key anytime for 1.5 sec. to go to the concerned group name.

※**[ ]** : This parameter may or may not appear, depending on the model and related parameter settings.

※If you press the **MODE** key after changing the setting value of the parameter the setting value will be stored.

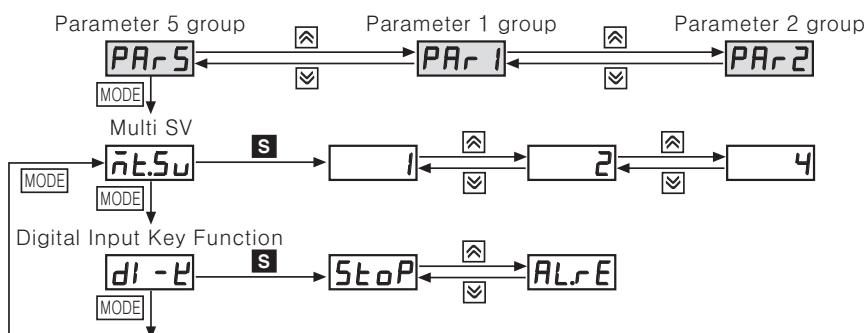

# TK Series

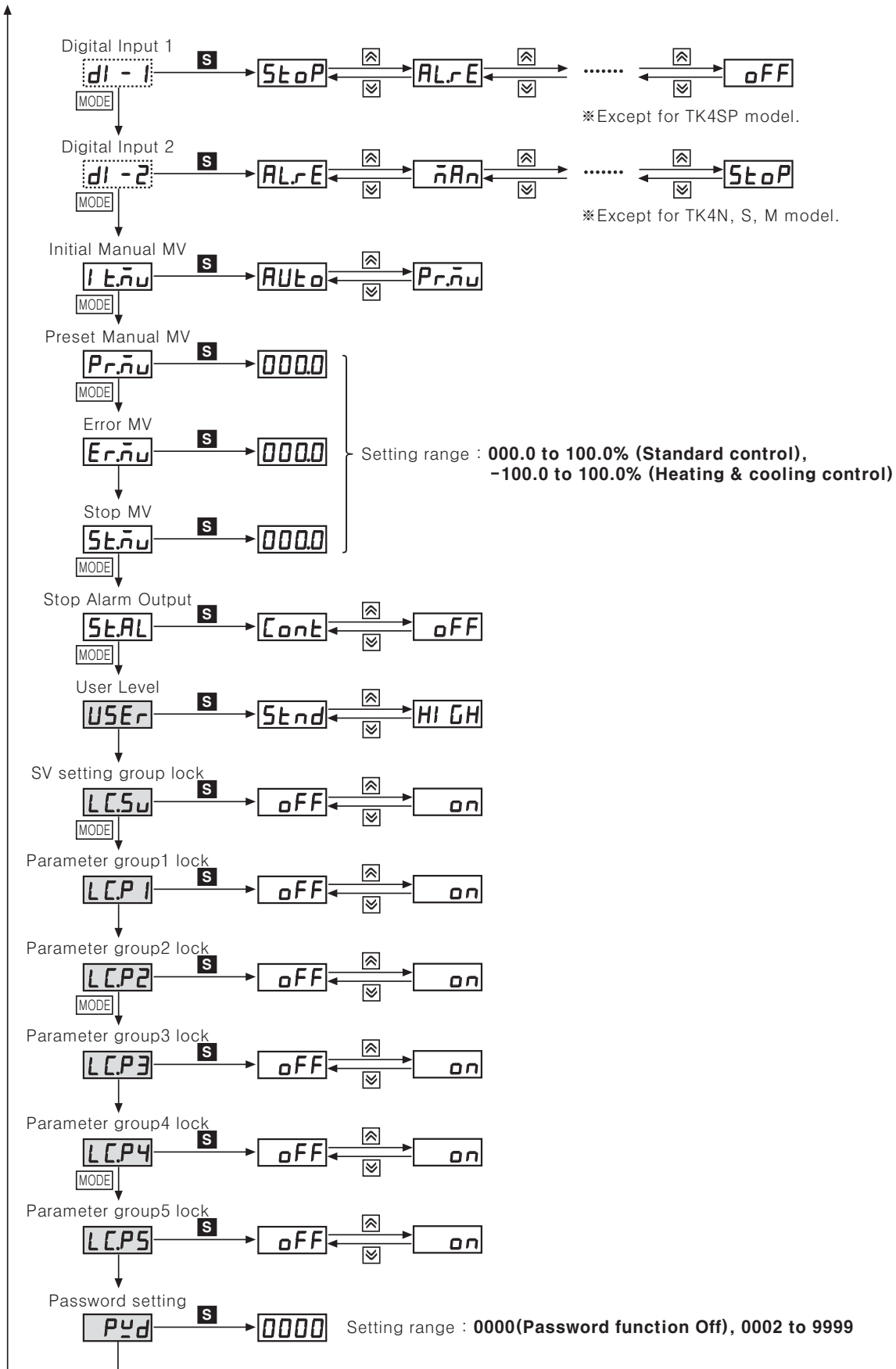

# High Function/High Performance PID Control

## Input sensor and range

Input sensor		Dot	Display	Input range(°C)	Input range(°F)	
Thermocouple	K(CA)	1	<b>ECRH</b>	-200 to 1350	-328 to 2463	
		0.1	<b>ECRL</b>	-199.9 to 999.9	-199.9 to 999.9	
	J(IC)	1	<b>JICH</b>	-200 to 800	-328 to 1472	
		0.1	<b>JICL</b>	-199.9 to 800.0	-199.9 to 999.9	
	E(CR)	1	<b>ECRH</b>	-200 to 800	-328 to 1472	
		0.1	<b>ECRL</b>	-199.9 to 800.0	-199.9 to 999.9	
	T(CC)	1	<b>TCRH</b>	-200 to 400	-328 to 752	
		0.1	<b>TCCL</b>	-199.9 to 400.0	-199.9 to 752.0	
	B(PR)	1	<b>bPr</b>	0 to 1800	32 to 3272	
	R(PR)	1	<b>rPr</b>	0 to 1750	32 to 3182	
	S(PR)	1	<b>sPr</b>	0 to 1750	32 to 3182	
	N(NN)	1	<b>n nn</b>	-200 to 1300	-328 to 2372	
	C(TT)(※1)	1	<b>Ctt</b>	0 to 2300	32 to 4172	
	G(TT)(※2)	1	<b>Gtt</b>	0 to 2300	32 to 4172	
	L(IC)	1	<b>LICH</b>	-200 to 900	-328 to 1652	
0.1		<b>LICL</b>	-199.9 to 900.0	-199.9 to 999.9		
U(CC)	1	<b>UCRH</b>	-200 to 400	-328 to 752		
	0.1	<b>UCLL</b>	-199.9 to 400.0	-199.9 to 752.0		
Platinel II	1	<b>PLII</b>	0 to 1390	32 to 2534		
RTD	CU 50Ω	0.1	<b>CU5</b>	-199.9 to 200.0	-199.9 to 392.0	
	CU 100Ω	0.1	<b>CU10</b>	-199.9 to 200.0	-199.9 to 392.0	
	JIS Standard	JPt 100Ω	1	<b>JPtH</b>	-200 to 650	-328 to 1202
		JPt 100Ω	0.1	<b>JPtL</b>	-199.9 to 650.0	-199.9 to 999.9
	DIN Standard	DPt 50Ω	0.1	<b>dPt5</b>	-199.9 to 600.0	-199.9 to 999.9
		DPt 100Ω	1	<b>dPtH</b>	-200 to 650	-328 to 1202
		DPt 100Ω	0.1	<b>dPtL</b>	-199.9 to 650.0	-199.9 to 999.9
Nickel 120Ω	1	<b>nI12</b>	-80 to 200	-112 to 392		
Analog	Voltage	0 to 10V	<b>Rv1</b>	-1999 to 9999 (Display point will be changed according to decimal point position.)		
		0 to 5V	<b>Rv2</b>			
		1 to 5V	<b>Rv3</b>			
		0 to 100mV	<b>Rv̄1</b>			
	Current	0 to 20mA	<b>R̄A1</b>			
		4 to 20mA	<b>R̄A2</b>			

(※1) Same as existing W5 (TT) type sensor (※2) Same as existing W(TT) type sensor

(A)	Photo electric sensor
(B)	Fiber optic sensor
(C)	Door/Area sensor
(D)	Proximity sensor
(E)	Pressure sensor
(F)	Rotary encoder
(G)	Connector/Socket
(H)	Temp. controller
(I)	SSR/Power controller
(J)	Counter
(K)	Timer
(L)	Panel meter
(M)	Tacho/Speed/Pulse meter
(N)	Display unit
(O)	Sensor controller
(P)	Switching power supply
(Q)	Stepping motor & Driver & Controller
(R)	Graphic/Logic panel
(S)	Field network device
(T)	Production stoppage models & replacement

# TK Series

## Alarm output operation mode

Mode	Alarm output operation	Description(Default Deviation)
<b>OFF</b>	—————	■ No alarm output
<b>duCC</b>	<p>High deviation : Set as 10°C      High deviation : Set as -10°C</p>	■ Deviation high-limit alarm (Temperature, analog : +F · S) If PV/SV deviation is occurring higher than set value of deviation temperature, alarm output will be ON. Deviation temperature is set in <i>AL 1.H / AL 2.H</i> .
<b>]]du</b>	<p>Lower deviation : Set as 10°C      Lower deviation : Set as -10°C</p>	■ Deviation low-limit alarm (Temperature, analog : +F · S) If PV/SV deviation is occurring lower than set value of deviation temperature, alarm output will be ON. Deviation temperature is set in <i>AL 1.L / AL 2.L</i> .
<b>]duC</b>	<p>Lower deviation : Set as 10°C , High deviation : Set as 20°C</p>	■ Deviation high / low-limit alarm (Temperature, analog : +F · S) If PV/SV deviation is occurring higher or lower than set value of deviation temperature, alarm output will be ON. High-limit deviation temperature is set in <i>AL 1.H / AL 2.H</i> . Low-limit deviation temperature is set in <i>AL 1.L / AL 2.L</i> .
<b>[du]</b>	<p>Lower deviation : Set as 10°C, High deviation : Set as 20°C</p>	■ Deviation high / low-limit reverse alarm (Temperature : 0, analog : 0) If PV/SV deviation is occurring higher or lower than set value of deviation temperature, alarm output will be ON. High-limit deviation temperature is set in <i>AL 1.H / AL 2.H</i> . Low-limit deviation temperature is set in <i>AL 1.L / AL 2.L</i> .
<b>PuCC</b>	<p>Absolute-value Alarm : Set as 90°C      Absolute-value Alarm : Set as 110°C</p>	■ Absolute value high-limit alarm (Temperature : High-limit value, analog : H-5C or L-5C, Select the higher one.) If PV is higher than absolute value of alarm temperature, alarm output will be ON. Absolute alarm value is set in <i>AL 1.H / AL 2.H</i> .
<b>]]Pu</b>	<p>Absolute-value Alarm : Set as 90°C      Absolute-value Alarm : Set as 110°C</p>	■ Absolute value low-limit alarm (Temperature: Low-limit value, Analog: H-5C or L-5C, Select the lower one.) If PV is lower than absolute value of alarm temperature, alarm output will be ON. Absolute alarm value is set in <i>AL 1.L / AL 2.L</i> .
<b>LbA</b>	It will be ON when it detects loop break.	■ Loop Break Alarm
<b>SbA</b>	It will be ON when it detects sensor disconnection.	■ Sensor Break Alarm
<b>HbA</b>	It will be ON when it detects heater break using CT.	■ Heater Break Alarm

## Optional alarm output selection [AL□.E]

Djisplay	Mode	Description
<b>AL-A</b>	Standard alarm	If it is an alarm condition, alarm output is ON. Unless an alarm condition, alarm output is OFF.
<b>AL-b</b>	Alarm latch	If it is an alarm condition, alarm output is ON. Before reset the alarm, an ON condition is latched. (Holding the alarm output)
<b>AL-C</b>	Standby sequence1	When power is supplied and it is an alarm condition, alarm output does not act. From the second alarm conditions, standard alarm acts. Conditions of repeated stanby sequence : Power ON
<b>AL-d</b>	Alarm latch and standby sequence1	When power is supplied and it is an alarm condition, alarm output does not act. From the second alarm conditions, alarm latch acts. Conditions of repeated stanby sequence : Power ON
<b>AL-E</b>	Standby sequence2	When Standby sequence and it is an alarm condition, alarm output does not act. After deactivate the alarm condition, standard alarm acts. Conditions of repeated Standby sequence : Power ON, Changing SV, Related alarm(operation mode, option, setting value), Changing parameter, Changing STOP mode to RUN mode.
<b>AL-F</b>	Alarm latch and standby sequence2	When Standby sequence is repeated and it is an alarm condition, alarm output does not act. After deactivate the alarm condition, alarm latch acts. Conditions of repeated Standby sequence : Power ON, Changing SV, Related alarm(operation mode, option, setting value), Changing parameter, Changing STOP mode to RUN mode.

# High Function/High Performance PID Control

## Front panel display when power is ON

When power is supplied, display will flash for 1 sec. Afterwards, model name and input sensor type will flash twice and then enter into RUN mode.

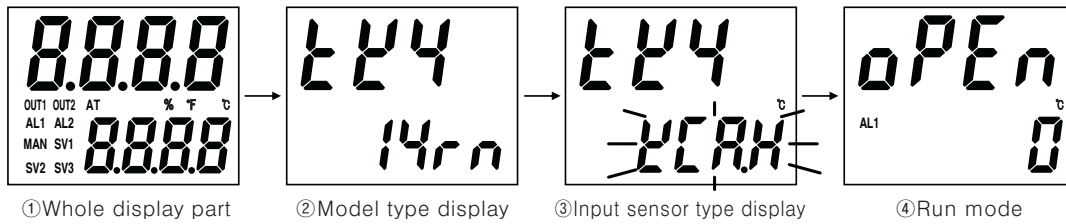

## Factory default

### SV setting group [ S<sub>v</sub> ]

Mode	Factory Default
S <sub>v</sub>	0

### Password input Parameter

Mode	Factory default
PA55	0001

### Parameter setting group 1 [ PA<sub>r-1</sub> ]

Mode	Factory default	Mode	Factory default	Mode	Factory default	Mode	Factory Default
r-S	rUn	AL1L	1550	AL2H	1550	S <sub>v-2</sub>	0000
S <sub>v-n</sub>	S <sub>v-0</sub>	AL1H	1550	S <sub>v-0</sub>	0000	S <sub>v-3</sub>	0000
Ct-A		AL2L	1550	S <sub>v-1</sub>	0000		

### Parameter setting group 2 [ PA<sub>r-2</sub> ]

Mode	Factory default	Mode	Factory default	Mode	Factory default	Mode	Factory default
At	oFF	H-d	0000	H.oSt	000	rAnU	000
H-P	010.0	C-d	0000	C.HYS	002	rAnd	000
C-P	010.0	db	0000	C.oSt	000	rUnk	nln
H-i	0000	rEst	050.0	L-nu	100.0 (Standard type)		
C-i	0000	H.HYS	002	H-nu	100.0 (Heating & Cooling type)		

### Parameter setting group 3 [ PA<sub>r-3</sub> ]

Mode	Factory default	Mode	Factory default	Mode	Factory default	Mode	Factory default
ln-t	E24H	H-SC	100.0	o-Ft	HEAt (Standard type)	o1Sr	Stnd
Unlt	oC	dUnk	oPo		H-C (Heating & Cooling type)	o1nA	4-20
L-rG	0000	ln-b	0000		PI d (Standard type)	oUt2	Curr
H-rG	10.00	nRwF	000.1		P.P (Heating & Cooling type)	o2nA	4-20
dot	0.0	L-Su	-200	Atk	tUn1	H-t	020.0 (Relay)
L-SC	000.0	H-Su	1350	oUt1	Curr	C-t	002.0 (SSR drive)

### Parameter setting group 4 [ PA<sub>r-4</sub> ]

Mode	Factory default	Mode	Factory default	Mode	Factory default	Mode	Factory default
AL-1	duCC	AL-2	JJdu	LbA.t	0000	RdrS	01
AL1.t	AL-A	AL2.t	AL-A	LbA.S	008	bPS	96
AL1.HY	001	AL2.HY	001	LbA.b	003	Prty	nonE
AL1.n	no	AL2.n	no	Ro-n	Pu	StP	2
AL1.on	0000	AL2.on	0000	F5-L	-200	rSy.t	20
AL1.oF	0000	AL2.oF	0000	F5-H	1350	CoNy	EnA

### Parameter setting group 5 [ PA<sub>r-5</sub> ]

Mode	Factory default	Mode	Factory default	Mode	Factory default	Mode	Factory default
n.t.Su	1	Pr.nu	000.0	LC.Su	oFF	LC.PS	oFF
di-t	StoP	Er.nu	000.0	LC.P1	oFF	PYd	0000
di-1	StoP	St.nu	000.0	LC.P2	oFF		
di-2	AL.rE	St.AL	Conk	LC.P3	oFF		
it.nu	AUto	USEr	Stnd	LC.P4	oFF		

- (A) Photo electric sensor
- (B) Fiber optic sensor
- (C) Door/Area sensor
- (D) Proximity sensor
- (E) Pressure sensor
- (F) Rotary encoder
- (G) Connector/Socket
- (H) Temp. controller
- (I) SSR/Power controller
- (J) Counter
- (K) Timer
- (L) Panel meter
- (M) Tacho/Speed/Pulse meter
- (N) Display unit
- (O) Sensor controller
- (P) Switching power supply
- (Q) Stepping motor & Driver & Controller
- (R) Graphic/Logic panel
- (S) Field network device
- (T) Production stoppage models & replacement

# TK Series

## Functions

### Control output operation mode [ $\sigma$ -Ft ]

- Control output modes for general temperature control include heating, cooling, and heating and cooling.
- Heating control and cooling control are mutually opposing operations with inverse outputs.
- The PID time constant varies based on the controlled objects during PID control.

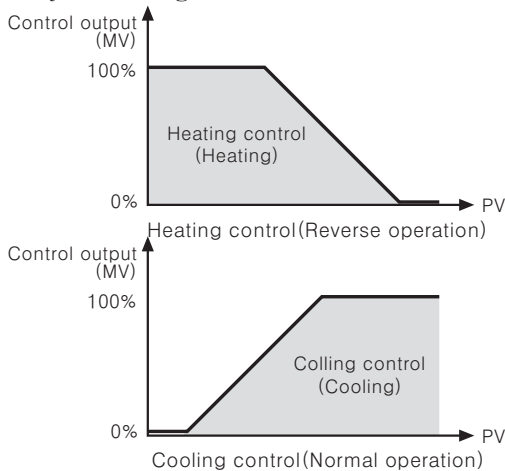

Setting group	Parameter	Setting range	Factory default	Unit
PRr3	$\sigma$ -Ft	Standard model HEAt / COoL	HEAt	-
		Heating & Cooling model HEAt / COoL / L-C	L-C	-

### Heating control [ HEAt ]

Heating control mode: the output will be provided in order to supply power to the load (heater) if PV (Present Value) falls below SV (Setting Value).

### Cooling control [ COoL ]

Cooling control mode: the output will be provided in order to supply power to the load (cooler) if PV (Present Value) rises above SV (Setting Value).

### Heating and cooling control [ H-C ]

Heating and cooling control mode: heating and cooling with a single temperature controller when it is difficult to control subject temperature with only heating or cooling.

Heating and cooling control mode controls the object using different PID time constants for each heating and cooling.

It is also possible to set heating and cooling control in both PID control or ON/OFF control mode. Heating/cooling output can be selected among Relay output, SSR output and current output depending on model types chosen according to your application environment. (Note that only standard SSR control is available for SSR output in OUT2.)

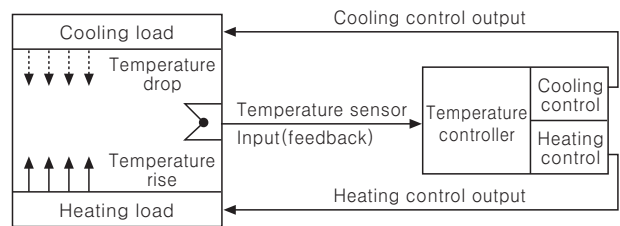

※ For heating and cooling control, OUT1 control output is dedicated to heating control and OUT2 control output to cooling control.

### Auto-tuning [ At ]

In PID control, auto-tuning determines the control subject's thermal characteristics and thermal response rate, and then determines the necessary PID time constant. Application of the PID time constant realizes fast response and high precision temperature control.

● Auto-tuning automatically stores PID time constants upon termination. These PID time constants can then be modified by the user to suit their usage environment.

● When auto-tuning is in progress, the AT lamp located on the front of the controller flashes in 1-second intervals. When auto-tuning finishes, the AT lamp automatically goes off and the auto-tuning parameter will return to OFF.

Setting value	Description
$\sigma$ FF	Auto-tuning complete.
$\sigma$ n	Auto-tuning in progress.

Setting group	Parameter	Setting range	Factory default	Unit
PRr2	At	$\sigma$ FF / $\sigma$ n	$\sigma$ FF	-

※ Manual interruption or a sensor disconnection error when auto-tuning is in progress restores the PID time constant to the value used prior to the auto-tuning session.

※ Auto-tuning continues to run even if the temperature reading exceeds or falls below the input range.

※ When auto-tuning is in progress, parameters can only be referenced and not altered.

※ Auto-tuning is not available in manual control.

### Control output (OUT1/OUT2) selection [ $\sigma$ Ut 1 / $\sigma$ Ut 2 ]

● In case of selecting the Models with current control output, both current and SSR outputs are available. You can therefore choose the right output type depending on application environments.

● OUT1 : Selects OUT1 control output.

● OUT2 : Selects OUT2 control output.

Setting group	Parameter	Setting range	Factory default	Unit
PRr3	$\sigma$ Ut 1	SSr / CURr	SSr	-
	$\sigma$ Ut 2			

● For more information, refer to user manual.

# High Function/High Performance PID Control

## ■ Proper usage

### ◎ Simple "error" diagnosis

- In case, the load (Heater etc) is not operated, please check operation of the out lamp located in front panel of the unit. If lamp does not operate, please check the parameter of all programmed mode. If lamp is operating, please check the output (Relay, Driving voltage of SSR, DC4–20mA current) after separating output line from the unit.
- When it displays "oPEo" during operation. This is a warning that external sensor is cut off. Please turn off power and check the state of sensor. If sensor is not cut off, disconnect sensor line from terminal block and +, – together. When you turn on power it can check room temperature. If this unit cannot indicate room temperature, this unit itself is faulty. Please remove this unit from equipment and service or replace. (When the input mode is thermocouple, it is available to indicate room temperature.)
- In case of indicating "Error" in display This Error message is indicated in case of damaging inner chip program data by outer strong noise. In this case, please send the unit to our after service center after removing the unit from system. Noise protection is designed in this unit, but it does not stand up strong noise continuously. If bigger noise than specified(Max. 2kV) flows in the unit, it can be damaged.

### ◎ Caution for using

- Please use the terminal(M3, Max. 5.8mm) when connecting the AC power source.
- "△" mark indicated on the diagram of this unit means caution—refer to accompanying documents.
- In case of cleaning the unit, please keep as following Cautions:
  - ① Clean dust with a dry tissue.
  - ② Be sure to use alcohol to clean the unit, do not use acid, chromic acid, solvent, etc.
  - ③ Be sure to clean the unit after turning off the power and then turn on the power after passing 30minute after cleaning.
- If this unit is used in a manner not to be specified by the manufacture, it can be injury to a person or damage to property.
- Be sure that metal dust and wire—dregs do not flow in the unit, because of malfunction damage of the unit or the cause of a fire.
- Service life for the relay of the unit is indicated in this manual, life cycle is different according to the load capacity and switching times, therefore please use the unit after checking the load capacity and switching times.
- Connect wires correctly after checking polarity of terminals.
- Do not use this unit as following place.
  - ① A place where dust, corrosive gas, oil, moisture are occurred.
  - ② A place where there are high humidity or freezing place.
  - ③ A place where sunshine, radiant heat is occurred.
  - ④ A place where vibration, shock is occurred.
- If the equipment is used in a manner not specified by the manufacture the protection provided by the equipment may be impaired.
- Please install power switch or circuit—breaker in order to cut power supply off.
- A switch or circuit—breaker meeting the relevant requirements of IEC947–1 and IEC947–3 shall be included in equipment when the temperature controller.
- The switch or circuit—breaker should be installed near by users.
- Installation environment
  - ① It shall be used indoor
  - ② Altitude Max. 2000m
  - ③ Pollution Degree 2
  - ④ Installation Category II.
- Be sure to power turn off when changing thermocouple to analog signal and change DIN switch setting. Then, power turn ON and change 2 setting group.
- This SSRP of this controller are insulate from internal power.
- Do not connect power line to sensor connecting part. The inner circuit may be damaged.

(A)	Photo electric sensor
(B)	Fiber optic sensor
(C)	Door/Area sensor
(D)	Proximity sensor
(E)	Pressure sensor
(F)	Rotary encoder
(G)	Connector/Socket
(H)	Temp. controller
(I)	SSR/Power controller
(J)	Counter
(K)	Timer
(L)	Panel meter
(M)	Tacho/Speed/Pulse meter
(N)	Display unit
(O)	Sensor controller
(P)	Switching power supply
(Q)	Stepping motor & Driver & Controller
(R)	Graphic/Logic panel
(S)	Field network device
(T)	Production stoppage models & replacement