

# **SYSMAC CJ Series**

## **CJ1W-CIF21**

### **Simple Communications Unit**

#### **Operation Manual**

*Produced September 2001*





## Notice:

OMRON products are manufactured for use according to proper procedures by a qualified operator and only for the purposes described in this manual.

The following conventions are used to indicate and classify precautions in this manual. Always heed the information provided with them. Failure to heed precautions can result in injury to people or damage to property.

 **DANGER** Indicates an imminently hazardous situation which, if not avoided, will result in death or serious injury.

 **WARNING** Indicates a potentially hazardous situation which, if not avoided, could result in death or serious injury.

 **Caution** Indicates a potentially hazardous situation which, if not avoided, may result in minor or moderate injury, or property damage.

## OMRON Product References

All OMRON products are capitalized in this manual. The word “Unit” is also capitalized when it refers to an OMRON product, regardless of whether or not it appears in the proper name of the product.

The abbreviation “Ch,” which appears in some displays and on some OMRON products, often means “word” and is abbreviated “Wd” in documentation in this sense.

The abbreviation “PC” means Programmable Controller and is not used as an abbreviation for anything else.

## Visual Aids

The following headings appear in the left column of the manual to help you locate different types of information.

**Note** Indicates information of particular interest for efficient and convenient operation of the product.

Indicates supplementary information on related topics that may be of interest to the user.

**1,2,3...** 1. Indicates lists of one sort or another, such as procedures, checklists, etc.

## © OMRON, 2001

All rights reserved. No part of this publication may be reproduced, stored in a retrieval system, or transmitted, in any form, or by any means, mechanical, electronic, photocopying, recording, or otherwise, without the prior written permission of OMRON.

No patent liability is assumed with respect to the use of the information contained herein. Moreover, because OMRON is constantly striving to improve its high-quality products, the information contained in this manual is subject to change without notice. Every precaution has been taken in the preparation of this manual. Nevertheless, OMRON assumes no responsibility for errors or omissions. Neither is any liability assumed for damages resulting from the use of the information contained in this publication.



# TABLE OF CONTENTS

|  |           |
|--|-----------|
| <b>PRECAUTIONS</b> .....                           | <b>xi</b> |
| 1 Intended Audience .....                          | xii       |
| 2 General Precautions .....                        | xii       |
| 3 Safety Precautions.....                          | xii       |
| 4 Application Precautions .....                    | xiii      |
| 5 Operating Environment Precautions .....          | xiv       |
| 6 Conformance to EC Directives .....               | xv        |
| <br>   |           |
| <b>SECTION 1</b>                                   |           |
| <b>Features and System Configuration</b> .....     | <b>1</b>  |
| 1-1 Introduction.....                              | 2         |
| 1-2 Processing Component Data .....                | 5         |
| <br>   |           |
| <b>SECTION 2</b>                                   |           |
| <b>Unit Components and Specifications</b> .....    | <b>9</b>  |
| 2-1 Specifications .....                           | 10        |
| 2-2 Component Names and Functions .....            | 10        |
| <br>   |           |
| <b>SECTION 3</b>                                   |           |
| <b>Preparation for Operation</b> .....             | <b>19</b> |
| 3-1 Procedure Outline .....                        | 20        |
| 3-2 Installation and Power Supply Wiring .....     | 20        |
| 3-3 Simple Communications Unit Connections .....   | 23        |
| 3-4 Simple Communications Unit Settings.....       | 25        |
| 3-5 PC Settings .....                              | 27        |
| 3-6 Connected Component Settings .....             | 27        |
| 3-7 DM Settings and Component Communications ..... | 27        |
| 3-8 Precautions for Component Communications ..... | 29        |
| 3-9 Troubleshooting .....                          | 31        |
| <br>   |           |
| <b>SECTION 4</b>                                   |           |
| <b>Allocations in the DM Area</b> .....            | <b>33</b> |
| 4-1 Data Memory (DM) Allocation .....              | 34        |
| 4-2 Shared Area.....                               | 35        |
| 4-3 Individual Unit Areas .....                    | 41        |
| <br>   |           |
| <b>Appendices</b>                                  |           |
| A Data Refresh Cycle (Reference Data) .....        | 53        |
| B Example Application .....                        | 57        |
| C DM Area Settings Assignment Sheets .....         | 65        |
| <br>   |           |
| <b>Revision History</b> .....                      | <b>73</b> |



## About this Manual:

This manual describes the installation and operation of the CJ1W-CIF21 Simple Communications Unit and includes the sections described below.

Please read this manual and all of the related manuals carefully and be sure you understand the information provided before attempting to install and operate the CJ1W-CIF21 Simple Communications Unit.

**Section 1** describes the features and system configuration of the CJ1W-CIF21 Simple Communications Unit.

**Section 2** provides specifications for the CJ1W-CIF21 Simple Communications Unit and describes the functions of each component.

**Section 3** describes preparatory procedures from installation of the CJ1W-CIF21 Simple Communications Unit to operation of the Unit.

**Section 4** describes the interface with the Components provided in the DM Area of the CPU Unit.

The **Appendices** provide information on the data refresh cycle, an application example, and DM Area settings assignment sheets.

Details on CPU Unit, Serial Communications Board, and Serial Communications Unit operation can be found in the following manuals.

| Manual  | Cat. No. |
|---|----------|
| SYSMAC CJ Series<br>CJ1G-CPU□□/CJ1G/H-CPU□□H<br>Programmable Controllers Operation Manual                           | W393     |
| SYSMAC CS Series<br>CS1G/H-CPU□□-EV1, CS1G/H-CPU□□H<br>Programmable Controllers Operation Manual                    | W339     |
| SYSMAC CS/CJ Series<br>CS1W-SCB21/41, CS1W-SCU21, CJ1W-SCU41<br>Serial Communications Boards/Units Operation Manual | W336     |
| SYSMAC CQM1H Series<br>CQM1H-CPU□□ Programmable Controllers<br>CQM1H-□□□□□ Inner Boards<br>Operation Manual         | W363     |
| SYSMAC CQM1H Series<br>CQM1H-SCB41 Serial Communications Boards<br>Operation Manual                                 | W365     |
| SYSMAC CPM2A<br>Programmable Controllers<br>Operation Manual  | W352     |



# PRECAUTIONS

This section provides general precautions for using the CJ1W-CIF21 Simple Communications Unit.

**The information contained in this section is important for the safe and reliable application of Programmable Controllers. You must read this section and understand the information contained before attempting to set up or operate a PC system.**

- 1 Intended Audience ..... xii
- 2 General Precautions ..... xii
- 3 Safety Precautions ..... xii
- 4 Application Precautions ..... xiii
- 5 Operating Environment Precautions..... xiv
- 6 Conformance to EC Directives..... xv
  - 6-1 Applicable Directives..... xv
  - 6-2 Concepts..... xv

## 1 Intended Audience

This manual is intended for the following personnel, who must also have knowledge of electrical systems (an electrical engineer or the equivalent).

- Personnel in charge of installing FA systems.
- Personnel in charge of designing FA systems.
- Personnel in charge of managing FA systems and facilities.

## 2 General Precautions

The user must operate the product according to the performance specifications described in the operation manuals.

Before using the product under conditions which are not described in the manual or applying the product to nuclear control systems, railroad systems, aviation systems, vehicles, combustion systems, medical equipment, amusement machines, safety equipment, and other systems, machines, and equipment that may have a serious influence on lives and property if used improperly, consult your OMRON representative.

Make sure that the ratings and performance characteristics of the product are sufficient for the systems, machines, and equipment, and be sure to provide the systems, machines, and equipment with double safety mechanisms.

This manual provides information for programming and operating the Unit. Be sure to read this manual before attempting to use the Unit and keep this manual close at hand for reference during operation.

 **WARNING** It is extremely important that a PC and all PC Units be used for the specified purpose and under the specified conditions, especially in applications that can directly or indirectly affect human life. You must consult with your OMRON representative before applying a PC System to the above-mentioned applications.

## 3 Safety Precautions

 **WARNING** Do not attempt to take any Unit apart while the power is being supplied. Doing so may result in electric shock.

 **WARNING** Do not touch any of the terminals or terminal blocks while the power is being supplied. Doing so may result in electric shock.

 **Caution** Tighten the terminal screws on the communication cable screws to the torque specified in this manual.

 **Caution** Refer to this manual when making settings and set the Simple Communications Unit correctly. Incorrect settings can cause unexpected operation and may result in property damage or injury.

## 4 Application Precautions

 **Caution** Failure to abide by the following precautions could lead to faulty operation of the PC or the system, or could damage the PC or PC Units. Always heed these precautions.

- When transporting the Unit, use special packing boxes. Be careful not to allow excessive vibration or shock to be applied during transportation and not to drop the products.
- Store the Unit within the following temperature and humidity ranges:  
Storage temperature: –20 to 75°C  
Storage humidity: 10% to 90% (with no icing or condensation)
- Install the Unit properly so that it does not fall.
- Always use the power supply voltage specified in the operation manual. An incorrect voltage may result in malfunction or burning.
- Set the communications distance to within the range specified in the operation manual.
- Do not place communications cables close to or parallel to high-voltage lines or power lines.
- Be sure to attach the labels supplied with the Unit or provide other protective covers when wiring in order to prevent dust or wire cuttings from entering the Unit.
- Remove the label after the completion of wiring to ensure proper heat dissipation. Leaving the label attached may result in malfunction.
- Wire terminals or connectors with the correct polarity and direction.
- Double-check all the wiring or the setting switches before turning ON the power supply. Incorrect wiring may result in burning.
- Before touching the Unit, be sure to first touch a grounded metallic object in order to discharge any static built-up. Not doing so may result in malfunction or damage.
- Use the specified connectors or wires.  
Terminal block for RS-422/485: AWG 28 to AWG 16, stripped wire length: 7 mm
- Always turn OFF the power supply to the PC before attempting any of the following. Not turning OFF the power supply may result in malfunction or electric shock.
  - Assembling the Units
  - Connecting or wiring the cables
  - Connecting or disconnecting the connectors
- Use the communications cables specified in the operation manual.
- Always use the power supply voltages specified in the operation manual. An incorrect voltage may result in malfunction or burning.
- Double-check the polarity when connecting the RS-422/485. Some devices may have reverse polarity (+/–) for SDA/SDB and RDA/RDB.
- When using the RS-422/485, operate only after confirming that terminating resistance has been set correctly.
- Do not pull on the cables or bend the cables beyond their natural limit. Doing either of these may break the cables.
- Do not place objects on the cables. Doing so may break the cables.

- Be sure that the terminal blocks, connectors, and other items with locking devices are properly locked into place. Improper locking may result in malfunction.
- Use the Unit with the cover mounted properly.
- Wire correctly as specified in the operation manual.
- Take appropriate measures to ensure that the specified power with the rated voltage and frequency is supplied. Be particularly careful in places where the power supply is unstable. An incorrect power supply may result in malfunction.

## 5 Operating Environment Precautions

 **Caution** Install the Unit properly, as described in this manual.

 **Caution** Do not operate the control system in the following locations:

- Locations subject to direct sunlight.
- Locations subject to temperatures or humidity outside the range specified in the specifications.
- Locations subject to condensation due to sudden temperature changes.
- Locations subject to corrosive or flammable gases.
- Locations subject to dust (especially iron dust) or salts.
- Locations subject to exposure to water, oil, or chemicals.
- Locations subject to shock or vibration.

 **Caution** Take appropriate and sufficient countermeasures when installing systems in the following locations:

- Locations subject to static electricity or other forms of noise.
- Locations subject to strong electromagnetic fields.
- Locations subject to possible exposure to radioactivity.
- Locations close to power lines.

## 6 Conformance to EC Directives

### 6-1 Applicable Directives

- EMC Directives
- Low Voltage Directive

### 6-2 Concepts

#### **EMC Directives**

OMRON devices that comply with EC Directives also conform to the related EMC standards so that they can be more easily built into other devices or the overall machine. The actual products have been checked for conformity to EMC standards (see the following note). Whether the products conform to the standards in the system used by the customer, however, must be checked by the customer.

EMC-related performance of the OMRON devices that comply with EC Directives will vary depending on the configuration, wiring, and other conditions of the equipment or control panel on which the OMRON devices are installed. The customer must, therefore, perform the final check to confirm that devices and the overall machine conform to EMC standards.

**Note** Applicable EMC (Electromagnetic Compatibility) standards are as follows:

EMS (Electromagnetic Susceptibility): EN61131-2

EMI (Electromagnetic Interference): EN50081-2

(Radiated emission: 10-m regulations)

#### **Low Voltage Directives**

Always ensure that devices operating at voltages of 50 to 1,000 VAC or 75 to 1,500 VDC meet the required safety standards for the PC (EN61131-2).

The CJ-series PCs comply with EC Directives. To ensure that the machine or device in which a CJ-series PC is used complies with EC Directives, the PC must be installed as follows:

- The PC must be installed within a control panel.
- Reinforced insulation or double insulation must be used for the DC power supplies.
- PCs complying with EC Directives also conform to the Common Emission Standard (EN50081-2). When a PC is built into a machine, however, the structure of the control panel, the affects of other devices, wiring, and other factors can affect performance, particularly in respect to radiated emission (10-m regulations). Even when using CJ-series PCs, which comply with EC Directives, the customer must, therefore, perform final checks to confirm that devices and the overall machine conform to EMC standards.



# SECTION 1

## Features and System Configuration

This section describes the features and system configuration of the CJ1W-CIF21 Simple Communications Unit.

|       |                                     |   |
|-------|-------------------------------------|---|
| 1-1   | Introduction .....                  | 2 |
| 1-1-1 | Features .....                      | 2 |
| 1-1-2 | System Configuration .....          | 2 |
| 1-1-3 | Compatible PCs and Components ..... | 3 |
| 1-2   | Processing Component Data .....     | 5 |



### 1-1-3 Compatible PCs and Components

#### Host (PC)

The CJ1W-CIF21 can be connected to a CJ-series, CS-series, CQM1H, or CPM2A CPU Unit, as well as to a CJ-series, CS-series, or CQM1H Serial Communications Board/Unit.

| PC        | Model number                        | Name                        |
|-----------|-------------------------------------|-----------------------------|
| CJ Series | CJ1G-CPU□□<br>CJ1G/H-CPU□□H         | CPU Unit                    |
|           | CJ1W-SCU41                          | Serial Communications Unit  |
| CS Series | CS1G/H-CPU□□(-EV1)<br>CJ1G/H-CPU□□H | CPU Unit                    |
|           | CS1W-SCB21                          | Serial Communications Board |
|           | CS1W-SCU21/41                       | Serial Communications Unit  |
| CQM1H     | CQM1H-CPU□□                         | CPU Unit                    |
|           | CQM1H-SCB41                         | Serial Communications Board |
| CPM2A     | CPM2A-□□C□□                         | CPU Unit                    |

#### Components

The following table shows the OMRON components equipped with SYSWAY or CompoWay/F communications that can be connected.

| Name                           | Series  | Model number | SYSWAY     |                                   | CompoWay/F connection | Comments  |
|--------------------------------|---|--------------|------------|-----------------------------------|-----------------------|---|
|                                |   |              | Connection | Segment information (See note 5.) |                       |   |
| Temperature Controllers        | Temperature Controllers                           | E5GN         | OK         | 1                                 | OK                    | ---   |
|                                |   | E5CN         | OK         | 1                                 | OK                    | ---   |
|                                |   | E5EN         | OK         | 1                                 | OK                    | ---   |
|                                |   | E5AN         | OK         | 1                                 | OK                    | ---   |
|                                | Digital Controllers, Standard Models              | E5CK         | OK         | 1                                 | No                    | ---   |
|                                |   | E5EK         | OK         | 1                                 | No                    | ---   |
|                                |   | E5AK         | OK         | 1                                 | No                    | ---   |
|                                | Digital Controllers (Valve Control)               | E5EK         | OK         | 1                                 | No                    | Communications specialized for valve control are not supported. |
|                                |   | E5AK         | OK         | 1                                 | No                    |   |
|                                | Digital Controllers (Programmable)                | E5CK-T       | No         | ---                               | No                    | ---   |
|                                |   | E5EK-T       | No         | ---                               | No                    | ---   |
|                                |   | E5AK-T       | No         | ---                               | No                    | ---   |
|                                | Digital Controllers (Programmable, Valve Control) | E5EK-T       | No         | ---                               | No                    | ---   |
|                                |   | E5AK-T       | No         | ---                               | No                    | ---   |
|                                | Temperature Controllers                           | E5EJ         | OK         | 1                                 | No                    | ---   |
|                                |   | E5AJ         | OK         | 1                                 | No                    | ---   |
| Fuzzy Temperature Controller   | E5AF  | OK           | 1          | No                                | ---                   |   |
| Modular Temperature Controller | E5ZN  | No           | ---        | OK                                | ---                   |   |
| Digital Controller Board       | E5ZM  | No           | ---        | OK                                | ---                   |   |
| Timers                         | Digital Timer/Counter                             | H8GN         | No         | ---                               | OK                    | ---   |

| Name                 | Series                       | Model number | SYSWAY                |                                   | CompoWay/F connection | Comments  |
|----------------------|------------------------------|--------------|-----------------------|-----------------------------------|-----------------------|---|
|                      |                              |              | Connection            | Segment information (See note 5.) |                       |   |
| Digital Panel Meters | Digital Panel Meter          | K3GN         | No                    | ---                               | OK                    | ---   |
|                      | Process Meter                | K3NX         | Limited functionality | 2                                 | Limited functionality | Some commands cannot be used.<br>Only the CompoWay/F variable area can be read. (See note 3.) |
|                      | Weighing Meter               | K3NV         |                       |                                   |                       |   |
|                      | Frequency/Rate Meter         | K3NR         |                       |                                   |                       |   |
|                      | Period Meter                 | K3NP         |                       |                                   |                       |   |
|                      | Up/Down Counting Meter       | K3NC         |                       |                                   |                       |   |
|                      | Temperature Meter            | K3NH         |                       |                                   |                       |   |
|                      | Intelligent Signal Processor | K3TS         | Limited functionality | 2                                 | No                    | SYSWAY connection only (See note 2.)  |

- Note**
1. Components that support only SYSWAY or CompoWay/F communications must be connected with that communications protocol.
  2. When a K3TS is connected, connect the other components by SYSWAY as well. The K3TS cannot be combined with components that communicate by CompoWay/F communications.
  3. When CompoWay/F communications are used for some Digital Panel Meters, present values and set values are stored in BCD format, unlike Temperature Controllers and Timers. (These values are stored in binary format with Temperature Controllers and Digital Timer/Counters.)
  4. There are some SYSWAY commands that are not supported by OMRON components. Refer to the component's manual and confirm the contents of CJ1W-CIF21 command groups before using SYSWAY communications.
  5. When SYSWAY communications are being used, it is necessary to set the "segment information" to indicate whether Temperature Controllers or Digital Panel Meters are connected. Refer to *Unit Communications Type (Offset: +7, +10, +13, ... , +97, and +100)* on page 38 for details on setting the segment information.

# 1-2 Processing Component Data

## Data Processing Basics

Reading and writing are performed cyclically when the Read and Write Command Bits are ON.

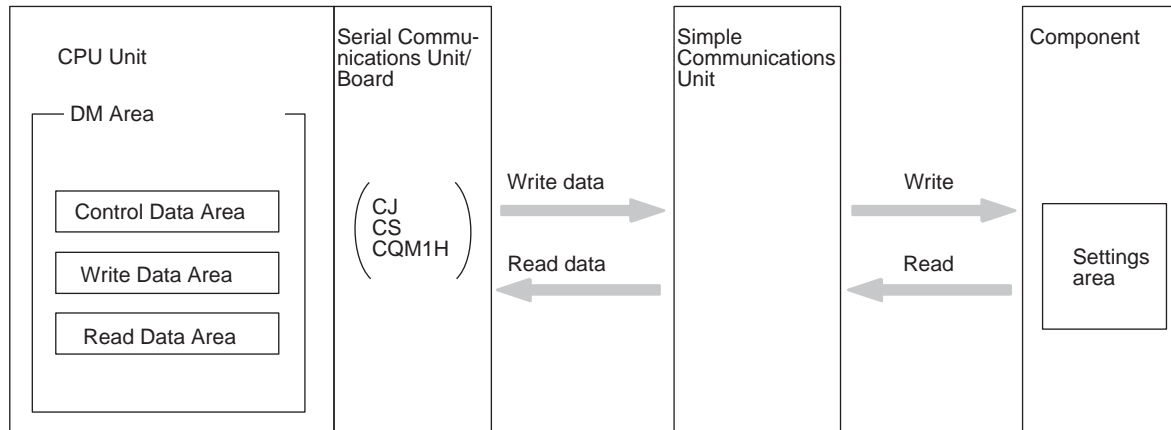

### Interface between the Simple Communications Unit and PC

The Simple Communications Unit interfaces with the CPU Unit through the CPU Unit's DM Area using the RS-232C or peripheral port on the CPU Unit or an RS-232C port on a Serial Communications Board or Unit.

### Interface between the Simple Communications Unit and the Components

The Simple Communications Unit interfaces with the OMRON components by transferring data with SYSWAY or CompoWay/F communications.

### Differences between SYSWAY and CompoWay/F

Data can be written between the Simple Communications Unit and OMRON components with SYSWAY or CompoWay/F communications. The methods used to read and write data are different in these communications protocols. (Some components are not limited to just one of these protocols.)

#### SYSWAY Communications

When SYSWAY communications are being used, there are 5 possible command groups. Select one of five command groups with which specified data will be transferred.

Also, the type of component being connected (Temperature Controller Unit or Digital Panel Meter) must be set when using SYSWAY communications. Different variables are transferred with Temperature Controller Units and Digital Panel Meters.

#### CompoWay/F Communications

When CompoWay/F communications are being used, the variables that will be transferred must be registered beforehand one-by-one. Up to 12 variable types can be registered. Register the variables that you want to write/read in the write variable type area and read variable type area.

When CompoWay/F communications are being used, only these registered variables can be written and read.

DM Area Structure

The following diagram shows the structure of the DM Area used for communications with the Simple Communications Unit.

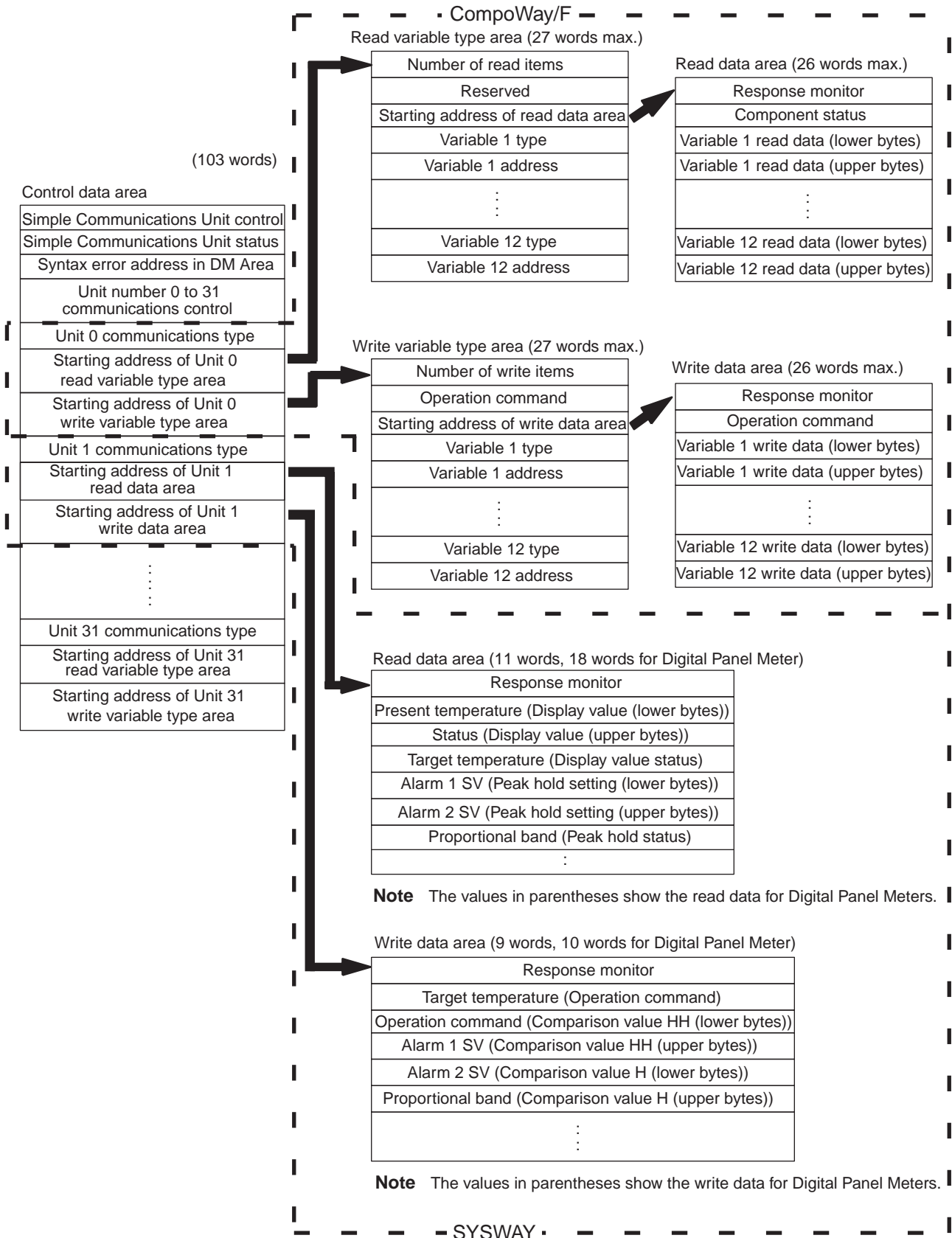

Flow of Data Processing

The following flowchart shows the flow of data processing.

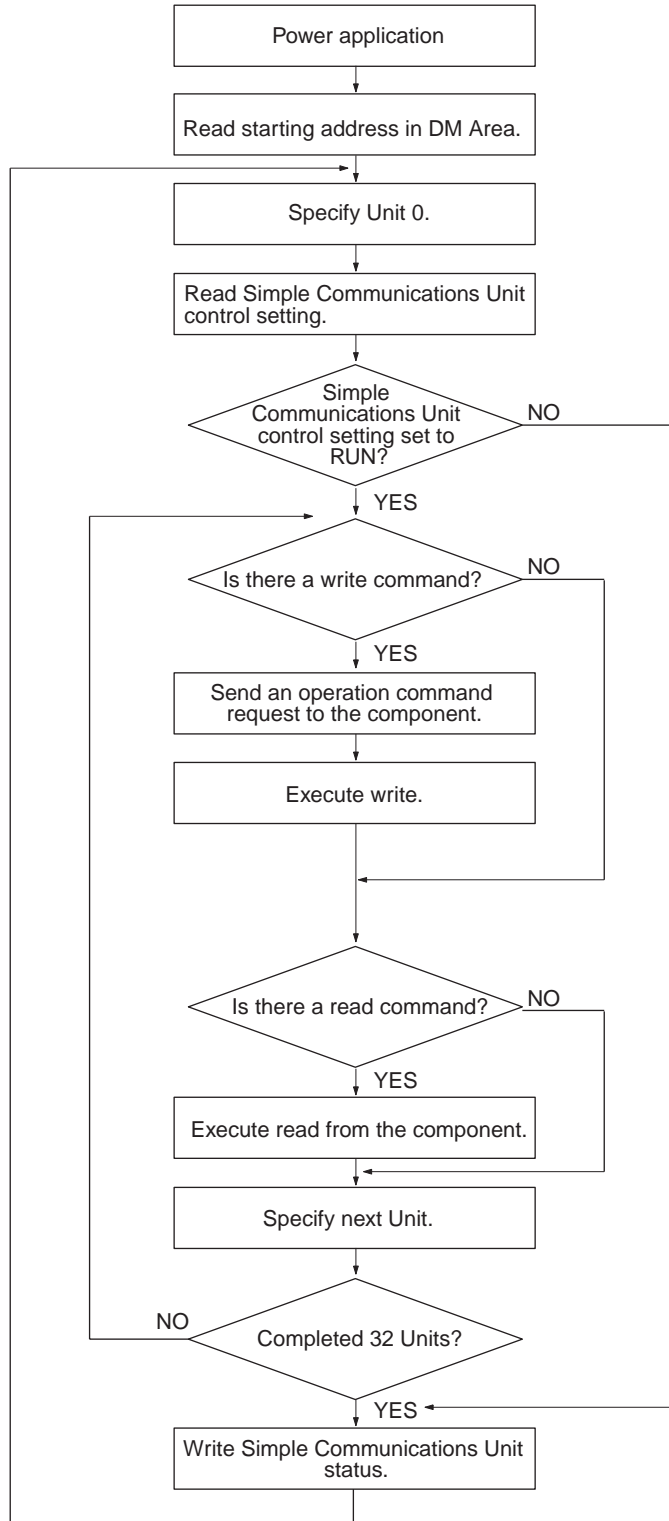



# SECTION 2

## Unit Components and Specifications

This section provides specifications for the CJ1W-CIF21 Simple Communications Unit and describes the functions of each component.

|       |   |    |
|-------|---|----|
| 2-1   | Specifications . . . . .                | 10 |
| 2-1-1 | Specifications . . . . .                | 10 |
| 2-1-2 | Dimensions . . . . .                    | 10 |
| 2-2   | Component Names and Functions . . . . . | 10 |

## 2-1 Specifications

### 2-1-1 Specifications

| Item                          | Specification                |
|-------------------------------|------------------------------|
| Power supply voltage          | 24 VDC (See note.)           |
| Allowable voltage range       | 20.4 to 26.4 VDC             |
| Power consumption             | 1.5 W                        |
| Ambient operating temperature | 0 to 55°C                    |
| Ambient operating humidity    | 10% to 90% (no condensation) |
| Ambient storage temperature   | -20 to 75°C                  |
| Weight                        | 150 g                        |

Note Provide a 24-VDC power supply to the power supply connector. Refer to 3-2-2 Power Supply Wiring for details.

### 2-1-2 Dimensions

The following diagram shows the external dimensions of the CJ1W-CIF21 Simple Communications Unit. All dimensions are in millimeters.

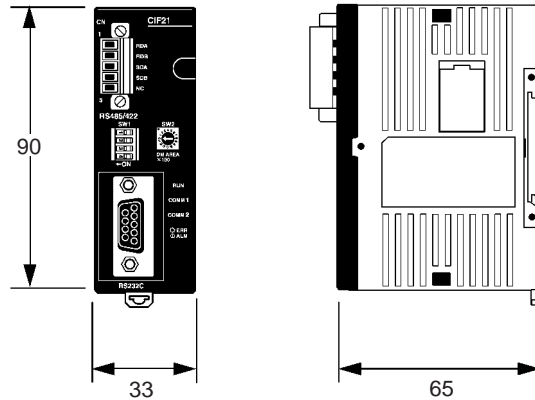

## 2-2 Component Names and Functions

### Front View

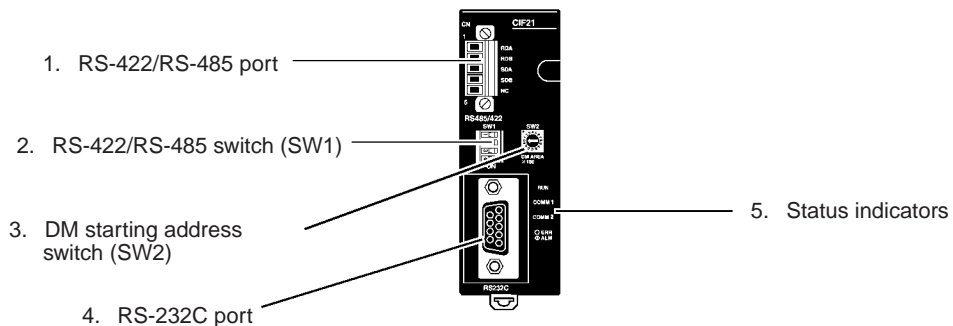

**Side View**

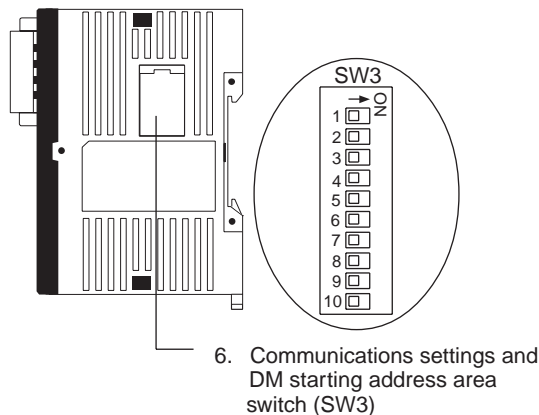

**Top View**

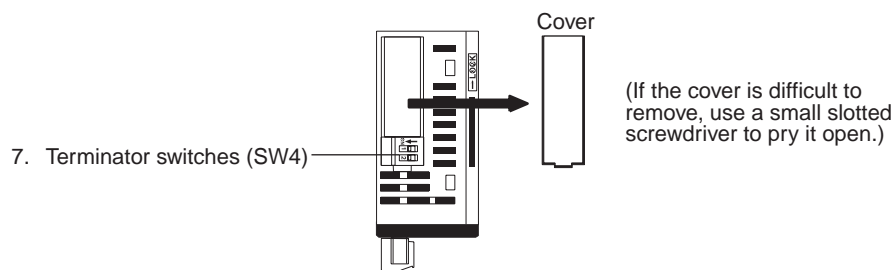

**Bottom View**

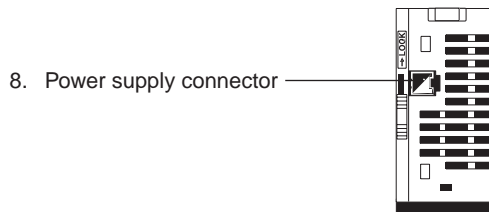

**1. RS-422/RS-485 Port**

Connects to the Temperature Controllers, Digital Timer/Counters, and Digital Panel Meters. Use either RS-422 or RS-485 connections; the two methods cannot be combined in a single CJ1W-CIF21.

Terminal Usage with an RS-422 Connection

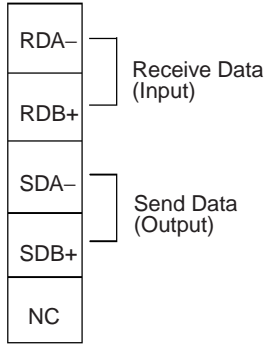

**Note** The maximum wire length is 500 m.

RS-422 Connection Example

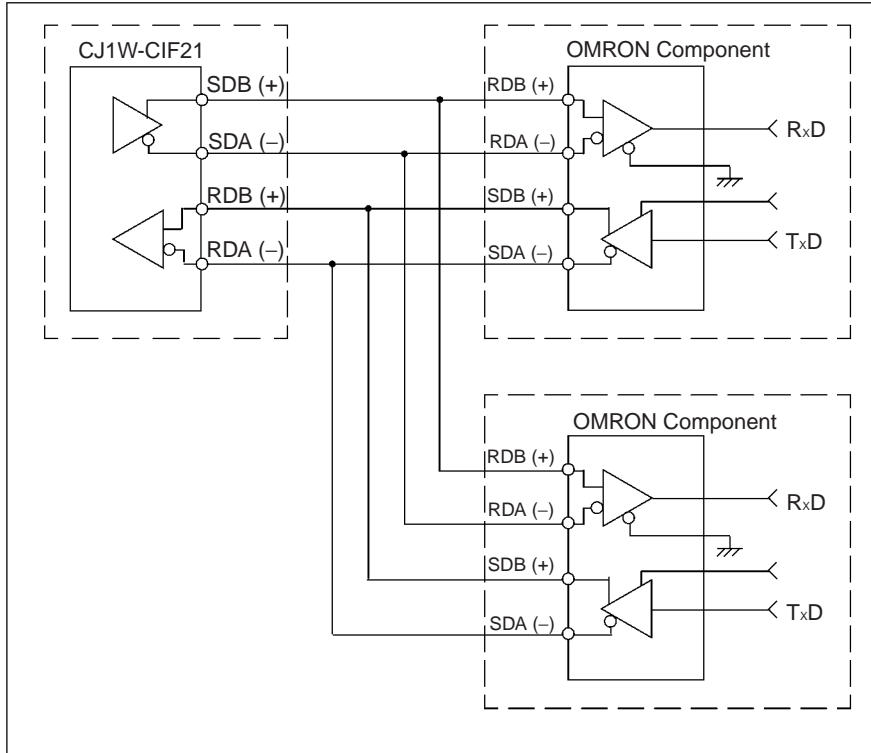

Terminal Usage with an RS-485 Connection

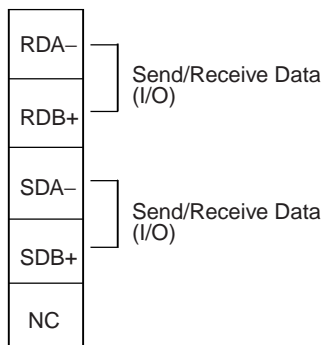

**Note** The maximum wire length is 500 m.

RS-485 Connection Example

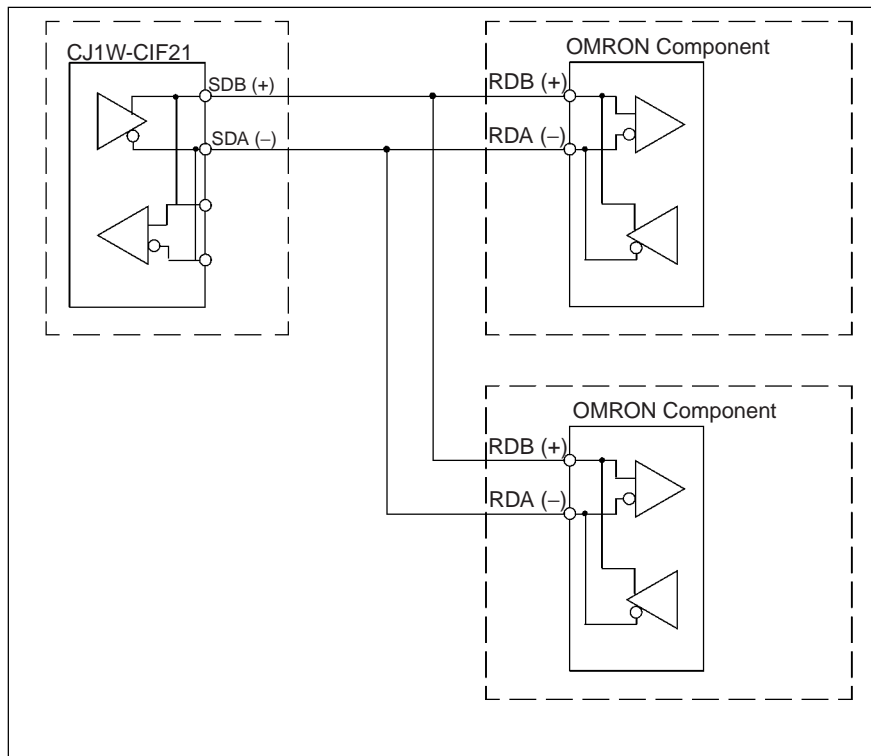

**Note** RS-422 and RS-485 cannot be used together.

RS-422/485 Interface Block Diagram

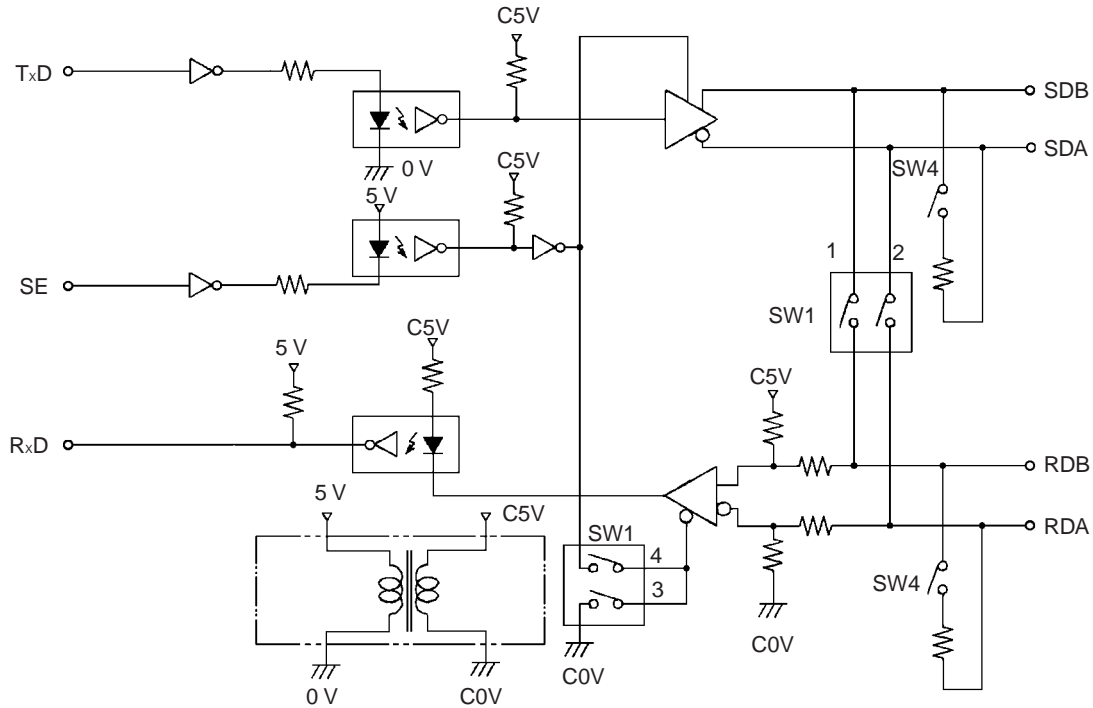

**2. RS-422/RS-485 Switch (SW1)** Selects RS-422 or RS-485 communications.

RS-422 setting    RS-485 setting

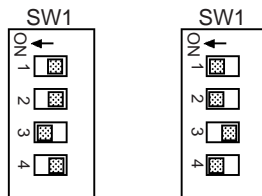

| SW1 | RS-422 | RS-485 |
|-----|--------|--------|
| 1   | OFF    | ON     |
| 2   | OFF    | ON     |
| 3   | ON     | OFF    |
| 4   | OFF    | ON     |

Note The factory setting is set for RS-485 (two-wire) communications. Do not turn ON both SW1-3 and SW1-4 at the same time. Doing so may destroy internal circuits.

**3. DM Starting Address Switch (SW2)**

Sets the starting address of the Simple Communications Unit's operational settings in the DM Area. This setting is used in combination with the DM starting address area set on pins 9 and 10 of the DIP switch located on the side of the Unit (SW3). (Refer to 6. Communications Settings and DM Starting Address Area (SW3) on page 16.) The following tables show the possible settings for the DM starting address switch (SW2) and DIP switch pins 9 and 10 (SW3).

- Note**
1. Always turn OFF pins 9 and 10 when connecting to a CPM2A PC.
  2. When connecting more than one Simple Communications Unit, set the starting address in the DM Area at least 200 words apart from each other so that the settings for the various Units do not overlap with each other.

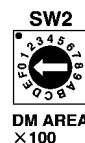

Setting range: 0 to F

**DM Starting Address Area: D0000 to D1500  
(Pin 9 OFF and pin 10 OFF on SW3)**

| SW2 setting | Starting address in DM Area |
|-------------|-----------------------------|
| 0           | D0000                       |
| 1           | D0100                       |
| 2           | D0200                       |
| 3           | D0300                       |
| 4           | D0400                       |
| 5           | D0500                       |
| 6           | D0600                       |
| 7           | D0700                       |
| 8           | D0800                       |
| 9           | D0900                       |
| A           | D1000                       |
| B           | D1100                       |
| C           | D1200                       |
| D           | D1300                       |
| E           | D1400                       |
| F           | D1500                       |

**DM Starting Address Area: D2500 to D4000  
(Pin 9 ON and pin 10 OFF on SW3)**

| SW2 setting | Starting address in DM Area |
|-------------|-----------------------------|
| 0           | D2500                       |
| 1           | D2600                       |
| 2           | D2700                       |
| 3           | D2800                       |
| 4           | D2900                       |
| 5           | D3000                       |
| 6           | D3100                       |
| 7           | D3200                       |
| 8           | D3300                       |
| 9           | D3400                       |
| A           | D3500                       |
| B           | D3600                       |
| C           | D3700                       |
| D           | D3800                       |
| E           | D3900                       |
| F           | D4000                       |

**DM Starting Address Area: D5000 to D6500  
(Pin 9 OFF and pin 10 ON on SW3)**

| SW2 setting | Starting address in DM Area |
|-------------|-----------------------------|
| 0           | D5000                       |
| 1           | D5100                       |
| 2           | D5200                       |
| 3           | D5300                       |
| 4           | D5400                       |
| 5           | D5500                       |
| 6           | D5600                       |
| 7           | D5700                       |
| 8           | D5800                       |
| 9           | D5900                       |
| A           | D6000                       |
| B           | D6100                       |
| C           | D6200                       |
| D           | D6300                       |
| E           | D6400                       |
| F           | D6500                       |

**DM Starting Address Area: D7500 to D9000  
(Pin 9 ON and pin 10 ON on SW3)**

| SW2 setting | Starting address in DM Area |
|-------------|-----------------------------|
| 0           | D7500                       |
| 1           | D7600                       |
| 2           | D7700                       |
| 3           | D7800                       |
| 4           | D7900                       |
| 5           | D8000                       |
| 6           | D8100                       |
| 7           | D8200                       |
| 8           | D8300                       |
| 9           | D8400                       |
| A           | D8500                       |
| B           | D8600                       |
| C           | D8700                       |
| D           | D8800                       |
| E           | D8900                       |
| F           | D9000                       |

**4. RS-232C Port**

Connects to the Simple Communications Unit to the RS-232C or peripheral port on a CPU Unit or to an RS-232C port on a Serial Communications Board or Unit.

**RS-232C Cable Wiring**

The following illustration shows the cable wiring for a CJ-series, CS-series, or CQM1H PC.

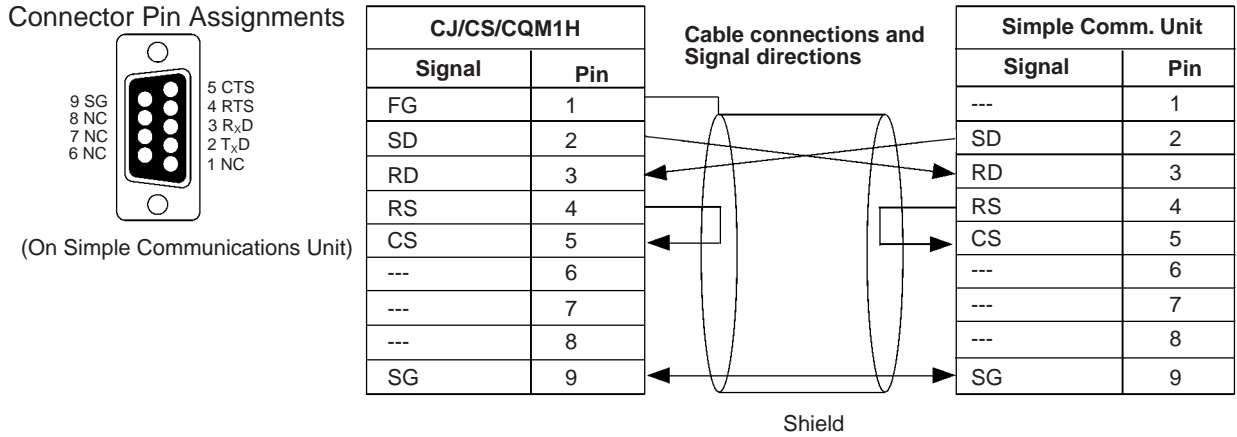

The following illustration shows the cable wiring for a CPM2A PC.

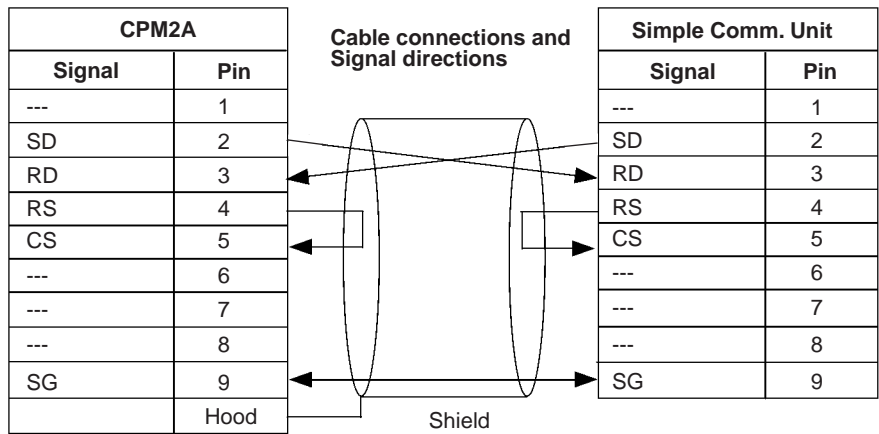

5. Status Indicators

Indicate the operating status of the Simple Communications Unit.

| Label   | Status   | Meaning  |
|---------|----------|--|
| RUN     | Lit      | Communications have been established between the Simple Communications Unit and the CPU Unit. The Simple Communications Unit is operating. |
|         | Not lit  | The Simple Communications Unit is not operating with the CPU Unit.   |
|         | Flashing | Communications between the Simple Communications Unit and the CPU Unit are not established or were interrupted.                            |
| ERR/ALM | Lit      | A fatal error occurred. (See note 1.)  |
|         | Flashing | A non-fatal error occurred. (See note 2.)  |
|         | Not lit  | Unit operating normally.   |
| COMM1   | Flashing | Data is being transferred between the Simple Communications Unit and the CPU Unit.   |
|         | Not lit  | Not transferring data  |
| COMM2   | Flashing | Data is being transferred between the Simple Communications Unit and connected components.   |
|         | Not lit  | Not transferring data  |

- Note**
1. The Simple Communications Unit stops operating when a fatal error occurs. Clear the cause of the error and turn the power ON again.
  2. The Simple Communications Unit continues operating when a non-fatal error occurs. Just clear the cause of the error or clear the error and stop/start operation to restore operation.

6. Communications Settings and DM Starting Address Area (SW3)

Sets the communications conditions used to communicate with the connected components and with the CPU Unit. Remove the cover on the side of the Unit to access this DIP switch (SW3).

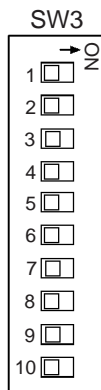

| Pin | Function   | OFF               | ON                                   |
|-----|--|-------------------|--------------------------------------|
| 1   | Baud rate for communications with CPU Unit (See note 3.) | Normal            | <b>9,600 bps</b> 19,200 bps          |
|     |  | High-speed        | 38,400 bps 57,600 bps                |
| 2   | Baud rate for communications with connected components   | Normal            | <b>9,600 bps</b> 19,200 bps          |
|     |  | High-speed        | 38,400 bps 57,600 bps                |
| 3   | Data length (See notes 2 and 3.)                         | <b>7 bits</b>     | 8 bits                               |
| 4   | Parity enable bit (See notes 2 and 3.)                   | <b>Use parity</b> | No parity                            |
| 5   | Parity (See notes 2 and 3.)                              | <b>Even</b>       | Odd                                  |
| 6   | Stop bits (See notes 2 and 3.)                           | <b>2 bits</b>     | 1 bit                                |
| 7   | Communications with CPU Unit                             | <b>Normal</b>     | High-speed                           |
| 8   | Communications with connected components                 | <b>Normal</b>     | High-speed                           |
| 9   | DM starting address area (See notes 4 and 5.)            | ---               | Pin 10 OFF                           |
| 10  |  | Pin 9 OFF         | <b>D0000 to D1500</b> D5000 to D6500 |
|     |  | Pin 9 ON          | D2500 to D4000                       |

- Note**
1. All pins are set to OFF at the factory. The factory settings are shaded in the above table.
  2. Pins 3, 4, 5, and 6 set communications conditions between the Simple Communications Unit and connected components only.
  3. The communications conditions with the CPU Unit are fixed to the following: 7 data bits, even parity, and 2 stop bits.
  4. When connected to a CPM2A CPU Unit, always turn OFF pins 9 and 10.

- When connecting more than one Simple Communications Unit, set the starting address in the DM Area at least 200 words apart from each other so that the settings for the various Units do not overlap with each other.

**7. Terminator Switches (SW4)**

Turn ON pins 1 and 2 if the Simple Communications Unit is at the end of the RS-422/RS-485 transmission path. Remove the cover on the top of the Unit to access SW4. If the cover is difficult to remove, use a small slotted screwdriver to pry it open.

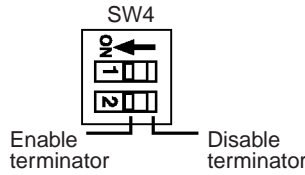

|                    | Pin 1 | Pin 2 |
|--------------------|-------|-------|
| Enable terminator  | ON    | ON    |
| Disable terminator | OFF   | OFF   |

- Note**
- Both pins are set to OFF at the factory.
  - The terminating resistance is 235  $\Omega$  with RS-422 communications. Keep the total combined terminating resistance above 110  $\Omega$ .
  - The terminating resistance is 118  $\Omega$  with RS-485 communications. Keep the total combined terminating resistance above 54  $\Omega$ .

**8. Power Supply Connector**

Connects to the 24-VDC power supply. Supply +24 V to the red wire and 0 V to the black wire of the power supply cord provided with the Unit.



# SECTION 3

## Preparation for Operation

This section describes preparatory procedures from installation of the CJ1W-CIF21 Simple Communications Unit to operation of the Unit.

|       |   |    |
|-------|---|----|
| 3-1   | Procedure Outline . . . . .                           | 20 |
| 3-2   | Installation and Power Supply Wiring . . . . .        | 20 |
| 3-2-1 | Installation . . . . .                                | 20 |
| 3-2-2 | Power Supply Wiring . . . . .                         | 22 |
| 3-3   | Simple Communications Unit Connections . . . . .      | 23 |
| 3-4   | Simple Communications Unit Settings . . . . .         | 25 |
| 3-5   | PC Settings . . . . .                                 | 27 |
| 3-6   | Connected Component Settings . . . . .                | 27 |
| 3-7   | DM Settings and Component Communications . . . . .    | 27 |
| 3-7-1 | DM Settings . . . . .                                 | 28 |
| 3-7-2 | Starting Communications with the Components . . . . . | 28 |
| 3-8   | Precautions for Component Communications . . . . .    | 29 |
| 3-9   | Troubleshooting . . . . .                             | 31 |
| 3-9-1 | Fatal Errors (ERR Indicator Lit) . . . . .            | 31 |
| 3-9-2 | Non-fatal Errors (ERR Indicator Flashing) . . . . .   | 32 |

### 3-1 Procedure Outline

The following diagram outlines the procedures required to prepare for communications with the connected OMRON components.

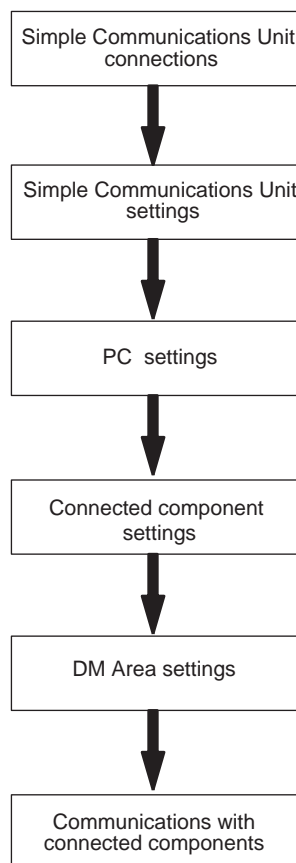

### 3-2 Installation and Power Supply Wiring

#### 3-2-1 Installation

Install the CJ1W-CIF21 Simple Communications Unit on a DIN Track that is 35-mm wide. The Unit must not be mounted directly to a panel or other surface.

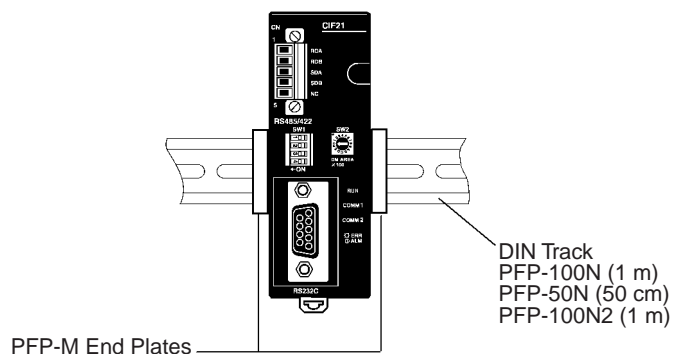

**Installing the Unit on DIN Track**

Hook the top of the Unit's mounting bracket onto the top of the DIN Track, pivot the Unit down completely, and lock the Unit to the bottom of the DIN Track.

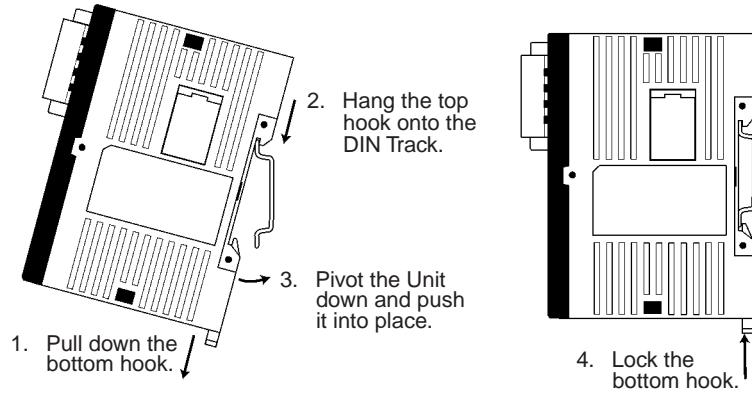

**Note** The DIN Track must be installed horizontally. If the Track is installed vertically, air will not flow properly through the Unit and the Unit may overheat.

**Removing the Unit from the DIN Track**

Use a standard slotted screwdriver to release the Unit's bottom hook. Pull the bottom of the Unit off of the DIN Track.

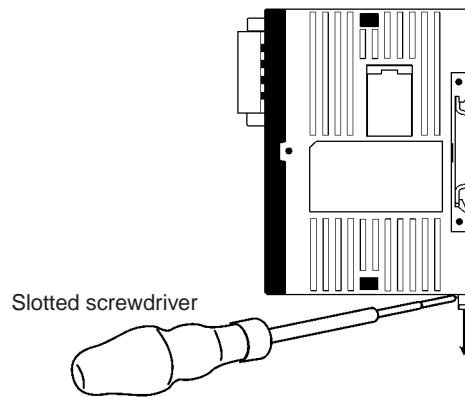

### 3-2-2 Power Supply Wiring

Use a DC power supply with sufficient capacity and low ripple. We recommend using the OMRON CPM2C-PA201 AC Power Supply Unit.

**⚠ Caution** Do not perform a voltage withstand test on the Unit's DC power supply terminals. The test might damage the Unit's internal components.

#### Using a General-purpose DC Power Supply

Connect the CJ1W-CIF21 Simple Communications Unit to a 24-VDC power supply with the power supply cord included with the Unit.

- 1,2,3...
1. Align the power supply cord's connector with the connector on the bottom of the Unit and insert it into the Unit.

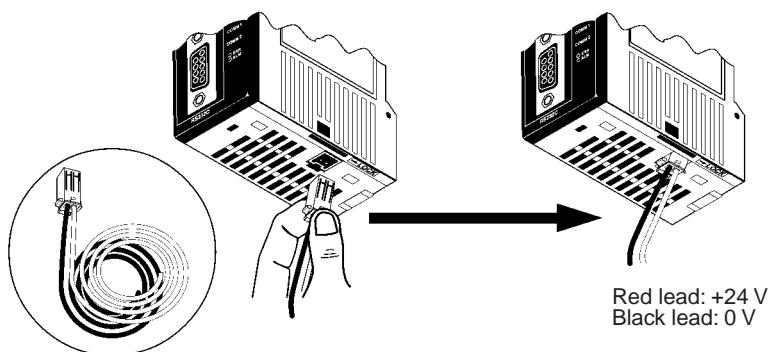

Power supply cord (Included with the Simple Communications Unit)  
Cable length: 100 cm

2. To remove the power supply cord, hold the cord's connector, press on the lock lever to release the connector's lock, and pull out the connector. Do not pull on the wires.

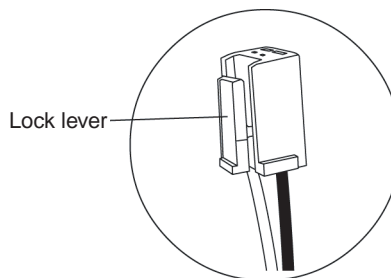

**Using a CPM2C-PA201 AC Power Supply Unit**

If you are using a CPM2C-PA201 Power Supply Unit, use the power supply cord included with the CPM2C-PA201 to connect to the CJ1W-CIF21 Simple Communications Unit.

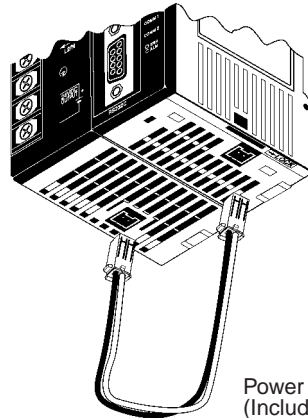

Power Supply Cord  
(Included with the CPM2C-PA201)  
Cable length: 23 cm

- Note**
1. Use a DC power supply with sufficient capacity and minimum ripple. The CPM2C-PA201 is recommended.
  2. Use double or reinforced insulation on the power supply whenever meeting the Low Voltage Directive of the EC Directives is necessary.

### 3-3 Simple Communications Unit Connections

Connect the CJ1W-CIF21 Simple Communications Unit to the PC and connect up to 32 OMRON components through the Unit's RS-422/RS-485 interface.

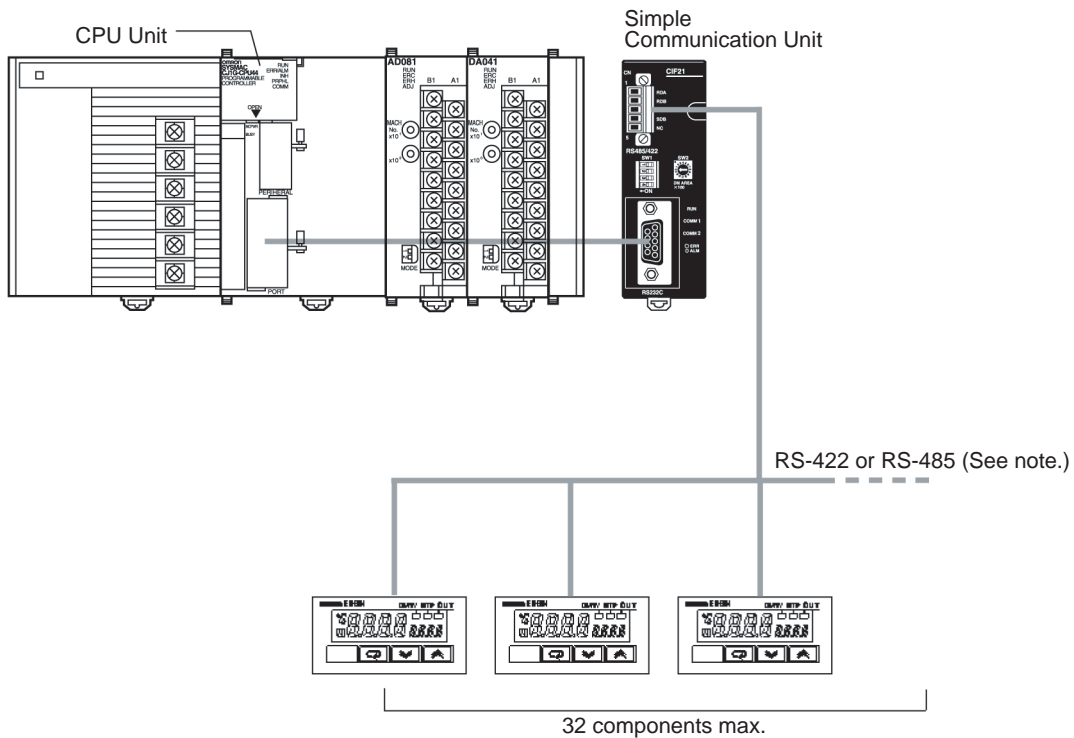

**Note** Use either RS-422 or RS-485. The two methods cannot be combined.

**RS-232C Wiring with 9-pin D-Sub on PC**

The following illustrations show the cable wiring between the Simple Communications Unit and the PC (CPU Unit, Serial Communications Board, or Serial Communications Unit).

**CJ-series, CS-series, CQM1H PC**

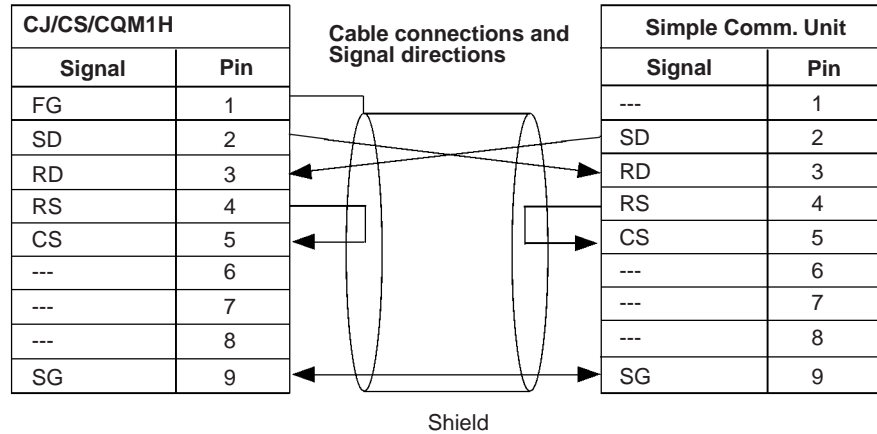

**CPM2A PC**

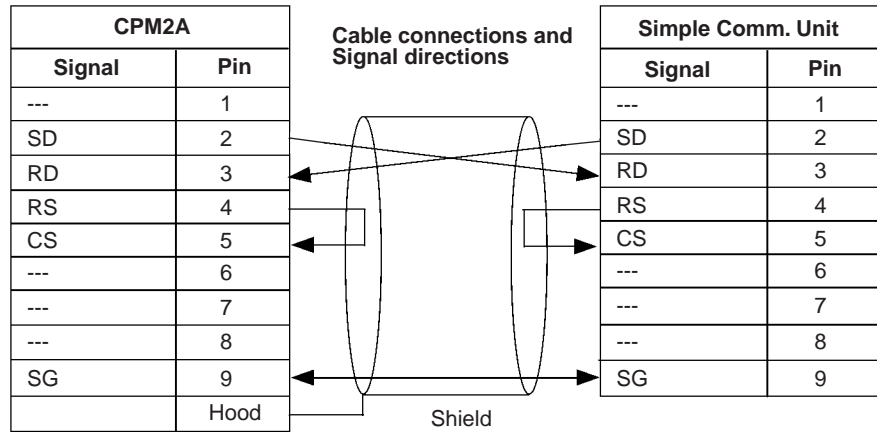

The following connectors can be used to connect the PC to the Simple Communications Unit.

- CJ-series, CS-series, or CQM1H PC

| Unit                             | Port on Unit                                | Model number                | Length           |
|----------------------------------|---|-----------------------------|------------------|
| CPU Unit                         | Built-in RS-232C port (D-Sub, 9-pin female) | XW2Z-200T/500T              | 2 or 5 m         |
|                                  | Peripheral port                             | CS1W-CN118 + XW2Z-200T/500T | 0.1 m + 2 or 5 m |
| Serial Communications Board/Unit | RS-232C port (D-Sub, 9-pin female)          | XW2Z-200T/500T              | 2 or 5 m         |

- CPM2A PC

| Unit     | Port on Unit                                | Model number                | Length            |
|----------|---|-----------------------------|-------------------|
| CPU Unit | Built-in RS-232C port (D-Sub, 9-pin female) | XW2Z-200T/500T              | 2 or 5 m          |
|          | Peripheral port                             | CPM1-CIF01 + XW2Z-200T/500T | 0.15 m + 2 or 5 m |

### 3-4 Simple Communications Unit Settings

Observe the following two precautions when changing the Unit's switch settings.

- Always turn OFF the power before changing the Simple Communications Unit's settings.
- To prevent malfunctioning from static discharge, never touch the setting switches when the power is ON.

**RS-422/RS-485 Switch (SW1)**

Selects whether RS-422 or RS-485 communications are used for communications with the connected OMRON components.

RS-422 setting    RS-485 setting

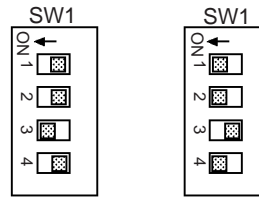

The following table shows the factory settings (RS-485 communications).

| SW1 pin | Factory setting | Function   |
|---------|-----------------|--|
| 1       | ON              | Selects RS-485 communications (two-wire communications). |
| 2       | ON              |  |
| 3       | OFF             |  |
| 4       | ON              |  |

Note See 2. RS-422/RS-485 Switch (SW1) on page 13 for more details on the function of SW1.

**DM Area Starting Address Setting (SW2)**

Sets the starting address of the Simple Communications Unit's operational settings in the DM Area. This setting is used in combination with the DM starting address area set on pins 9 and 10 of the DIP switch located on the side of the Unit (SW3).



The following table shows the factory settings for SW2 and SW3 pins 9 and 10.

| SW2 | SW3 pin 9 | SW3 pin 10 | Starting address in the DM Area |
|-----|-----------|------------|---------------------------------|
| 0   | OFF       | OFF        | D0000                           |

- Note**
1. Refer to 3. DM Starting Address Switch (SW2) on page 13 for tables showing all of the possible settings of SW2 and SW3 pins 9 and 10.
  2. When connected to a CPM2A CPU Unit, always turn OFF pins 9 and 10.
  3. When connecting more than one Simple Communications Unit, set the starting address in the DM Area at least 200 words apart from each other so that the settings for the various Units do not overlap with each other.

**Communications Settings and DM Starting Address Area (SW3)**

Sets the baud rate with the CPU Unit, the baud rate and communications conditions with the connected components, and the area in DM Area where the first word used by the Simple Communications Unit can be set. Set the same baud rates and communications settings in the PC and communications components. (Set the PC's communications conditions as follows: 7 data bits, even parity, and 2 stop bits.)

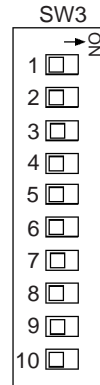

| Pin | Factory | Function                                      | Communications       |
|-----|---------|---|----------------------|
| 1   | OFF     | Baud rate = 9,600 bps                         | CPU Unit             |
| 2   | OFF     | Baud rate = 9,600 bps                         | Connected components |
| 3   | OFF     | Data length = 7 bits                          |                      |
| 4   | OFF     | Parity = Enabled                              |                      |
| 5   | OFF     | Parity = Even                                 |                      |
| 6   | OFF     | Stop bits = 2 bits                            |                      |
| 7   | OFF     | Communications mode = Normal (not high-speed) | CPU Unit             |
| 8   | OFF     | Communications mode = Normal (not high-speed) | Connected components |
| 9   | OFF     | DM Starting Address Area: D0000 to D1500      | ---                  |
| 10  | OFF     |   |                      |

- Note**
1. When connected to a CPM2A CPU Unit, always turn OFF pins 9 and 10.
  2. When connecting more than one Simple Communications Unit, set the starting address in the DM Area at least 200 words apart from each other so that the settings for the various Units do not overlap with each other.
  3. Refer to 6. *Communications Settings and DM Starting Address Area (SW3)* on page 16 for more details on SW3 pin settings.

**Terminator Switches (SW4)**

Turn ON pins 1 and 2 if the Simple Communications Unit is at the end of the RS-422/RS-485 transmission path. The factory setting for SW4 is both pins OFF (no terminating resistance.)

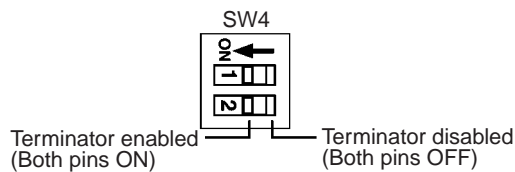

- Note**
1. The terminating resistance is 235  $\Omega$  with RS-422 communications. Keep the total combined terminating resistance above 110  $\Omega$ .
  2. The terminating resistance is 118  $\Omega$  with RS-485 communications. Keep the total combined terminating resistance above 54  $\Omega$ .

## 3-5 PC Settings

Make the following settings for the PC (CPU Unit, Serial Communications Board, or Serial Communications Unit).

| Setting name                      | Setting                        | Remarks  |
|-----------------------------------|--------------------------------|--|
| Serial communications mode        | Host Link                      | ---  |
| Baud rate                         | 9,600/19,200/38,400/57,600 bps | Set to match the Simple Communications Unit's setting. |
| Data length                       | 7 bits                         | ---  |
| Parity enable/disable             | Enable parity                  | ---  |
| Parity even/odd setting           | Even                           | ---  |
| Stop bits                         | 2 bits                         | ---  |
| Host Link number<br>(See note 1.) | 00                             | ---  |

- Note**
1. Set the Host Link number to 00. Operation will not be possible with any other number.
  2. The range of DM Area addresses that can be used depends on the PC that is being connected. Check the applicable DM Area address range in the CPU Unit and do not exceed it.
  3. Although the CS/CJ-series CPU Units support addresses D00000 to D32767 in the DM Area, the Simple Communications Unit must be allocated addresses between D00000 and D09999.

## 3-6 Connected Component Settings

Make the following settings in the components connected to the Simple Communications Unit. Refer to the component's manuals for details on these settings.

|   |  |
|---|--|
| <b>Unit Number</b>                          | Set the component's unit number between 0 and 31. Set a unique unit number on each component.  |
| <b>Communications Settings</b>              | Set the same communications settings that were set for the Simple Communications Unit in <i>page 25 Simple Communications Unit Settings</i> .  |
| <b>Enable Remote Communications Writing</b> | Specify "Enable Communications Writing (Remote)" for the setting mode. If "Disable Communications Writing (Local)" is specified, it won't be possible to change the component's SVs. |
| <b>Terminating Resistance</b>               | Terminating resistance must be set on the components at the ends of the RS-422/RS-485 communications cable. Turn on the termination resistance switch on the last component.         |

## 3-7 DM Settings and Component Communications

This section explains the basic procedures required to communicate with connected components. Refer to *SECTION 4 Allocations in the DM Area* for details on DM settings and setting procedures.

Write the following program sections in the user program to establish communications with the connected components.

### 3-7-1 DM Settings

Verify that the components that you want to connect are supported by the CJ1W-CIF21. Determine whether the components will communicate by SYSWAY or CompoWay/F communications.

Write the following program sections at the beginning of the user program so that the DM settings are made when the PC is turned ON.

When more than one Simple Communications Unit is connected, set the system so that the Control Data Areas and the Individual Unit Areas do not overlap.

- 1,2,3...**
1. Parameter Settings in the Control Data Area
    - Set the number of connected components (32 max.)
    - When using SYSWAY, set each component's segment information.
    - When using SYSWAY, select and set a command group that contains the values that you want to read or write.
    - Set the communications protocol.
    - When using SYSWAY, set the starting addresses of each component's read/write data areas.
    - When using CompoWay/F, set the starting addresses of each component's read/write variable type areas.
  2. When using CompoWay/F, set the variable type and variable address of each variable that you want to read or write. (Set this information in the read/write variable type area.)
  3. When writing data, set the data that you want to write in the write data area.

### 3-7-2 Starting Communications with the Components

Use the following procedure to start communications with the components.

- 1,2,3...**
1. Set the rightmost digit of the "Simple Communications Unit control" word in the Control Data Area (the RUN/Stop digit) to 1 (RUN).
  2. Turn ON the Read Command Bit or Write Command Bit of the desired component. (These bits are in the Control Data Area with word offsets +3, +4, +5, and +6. See *Communications Control Bits (Offset: +3, +4, +5, and +6)* on page 37.)

Changes to the following values are recognized only when the Simple Communications Unit control word's RUN/Stop digit is switched from Stop to RUN. When one of these values has been changed, switch the Simple Communications Unit from RUN to Stop and then back to RUN again.

- Segment information
- Command group
- Communications protocol
- Starting addresses of read/write data areas
- Starting addresses of read/write variable type areas

**Note** Refer to *Simple Communications Unit Control (Offset: +0)* on page 36 for details on the RUN/Stop Digit.

## 3-8 Precautions for Component Communications

Observe the following precautions when communicating with components.

|  |   |
|--|---|
| <b>Time Required to Refresh Read/Write Data</b>                      | The time required to refresh read or write data varies with the PC's cycle time. In addition, the refreshing interval is not fixed.   |
| <b>Establishing Communications with the PC</b>                       | Turn ON the Simple Communications Unit and the PC at the same time or turn ON the Simple Communications Unit after the PC has started. The Unit's RUN indicator will flash until communications are established with the PC. After communications are established, the RUN indicator will be lit or not lit depending on the status of Simple Communications Unit control.  |
| <b>No Response from PC after Communications were Established</b>     | If communications were established with the PC and later there is no response from the PC, the Unit will retry communications with the PC for 2 minutes. If there is no response after 2 minutes, a fatal error will occur and the ERR indicator will light.  |
| <b>Communications with Connected Components</b>                      | When an error occurs in communications between the Simple Communications Unit and a connected component, a non-fatal error will occur in the Unit and the Unit will stop communications with that component. The Unit writes the corresponding error code in the Response Monitor Area and the ERR indicator flashes, but the Unit continues operating and proceeds to communications with the next component. The ERR indicator will stop flashing if the Unit communicates successfully with the next component.  |
| <b>Operating Mode of the CPU Unit</b>                                | <p>It is not possible for the Simple Communications Unit to write data to the CPU Unit if the CPU Unit is in RUN mode. Just before writing data, the CPU Unit's operating mode is checked with the STATUS READ host link command. If the CPU Unit is found to be in RUN mode, the mode is changed to MONITOR mode with the STATUS WRITE host link command so that the data can be written.</p> <p>When a data write error occurs because the CPU Unit was changed to RUN mode from a Programming Device, the Simple Communications Unit will attempt to change the operating mode and write data twice. If these retries fail, a fatal error will occur and the ERR indicator will light.</p> |
| <b>Switching the Simple Communications Unit from "Stop" to "RUN"</b> | <p>The Simple Communications Unit must be switched from Stop to RUN in order to validate any changes made in Control Data Area words +7 through +102. After editing these words, always switch the Unit from RUN to Stop and then back to RUN again. Refer to <i>Simple Communications Unit Control (Off-set: +0)</i> on page 36 for details on the RUN/Stop Digit.</p> <p><b>Note</b> The Communications Control Area (Read and Write Command Bits) and the CompoWay/F Read and Write Variable Type Areas are read every scan, so it is not necessary to switch the Unit from Stop to RUN after these areas have been edited.</p>  |
| <b>Syntax Errors</b>   | <p>When a syntax error occurs in the Simple Communications Unit, switch the Unit from RUN to Stop, edit the location that caused the syntax error, and then switch the Unit back to RUN.</p> <p>Syntax errors are non-fatal errors that are cleared by switching the Unit from Stop to RUN. Non-fatal errors are not cleared just by eliminating the cause of the error.</p>  |
| <b>DM Area Allocation Errors</b>                                     | When a DM Area allocation error occurs, it is possible that the allocated DM Area words exceed the range of the PC's DM Area. After correcting the DM Area allocation, reset the power supply for the Simple Communications Unit.   |

DM Area allocation errors are fatal errors that are cleared by turning the power supply OFF and then ON again. Fatal errors are not cleared just by eliminating the cause of the error.

#### Delaying the Communications Response with Connected Components

The communications timeout setting must be extended if you are using a system configuration that causes a significant delay in the communications response between the Simple Communications Unit and the components, such as wireless communications between the Unit and components. The communications timeout setting can be set in multiples of 500 ms, up to the maximum monitoring time of 5.0 s. Set a monitoring time appropriate for your system.

**Note** Under normal conditions, it is not necessary to change the communications timeout setting. In general use a setting of 0, which sets a response monitoring time of 500 ms. Refer to *Simple Communications Unit Control (Offset: +0)* on page 36 for details on the communications timeout setting.

#### Selecting RAM Write Mode or Backup Mode

When selecting the RAM write mode or backup mode, program the selection operation command so that it is sent in only one scan. Some components write to non-volatile memory when this command is received, so the service life of the non-volatile memory will be reduced if the command is received every scan.

#### DM Area Settings for Multiple Simple Communications Units

When more than one Simple Communications Unit is connected, set the system so that the Control Data Areas and the Individual Unit Areas do not overlap.

### 3-9 Troubleshooting

The Simple Communications Unit can detect two kinds of errors: fatal errors cause the ERR indicator to light and non-fatal errors cause the ERR indicator to flash. The following tables show the likely causes of these errors and the process to clear the errors.

#### 3-9-1 Fatal Errors (ERR Indicator Lit)

| Error   | Likely cause and correction  |
|---|--|
| Communications cannot be established with the CPU Unit. | Check the communications baud rate and other communications settings in the CPU Unit and Simple Communications Unit. Correct the settings and turn ON the Simple Communications Unit again.  |
| There was a communications error with the CPU Unit.     | Noise can cause communications errors. If noise is suspected, use cables and wiring methods that will reduce noise in the communications lines and turn ON the Simple Communications Unit again.   |
| Cannot write data while the CPU Unit is in RUN mode.    | Check whether the CPU Unit is in RUN mode. If so, switch the CPU Unit to MONITOR mode or PROGRAM mode and turn ON the power again.   |
| A watchdog timer error occurred. (See note.)            | <p>Watchdog timer errors are indicated in the Simple Communications Unit status word. (Refer to <i>Simple Communications Unit Status (Offset: +1)</i> on page 36.)</p> <p>It is possible for noise to affect the Simple Communications Unit's processing. If noise is suspected, take steps to reduce noise around the Unit or shield the Unit.</p> <p>The watchdog timer error can be cleared by turning the power supply OFF and then ON again.</p>  |
| DM allocation error (See note.)                         | <p>The DM allocation may exceed the boundary of the CPM2C's DM Area. When a DM allocation error is detected, error code "15" is written to the Simple Communications Unit Status word (see <i>Simple Communications Unit Status (Offset: +1)</i> on page 36).</p> <p>To restore normal operation, correct the DM allocation and switch the Unit from RUN to Stop and then back to RUN again. Refer to <i>Simple Communications Unit Control (Offset: +0)</i> on page 36 for details on the RUN/Stop Digit.</p> |

**Note** Watchdog timer errors and DM allocation errors are indicated in the Simple Communications Unit status word. (Refer to *Simple Communications Unit Status (Offset: +1)* on page 36 for details.)

### 3-9-2 Non-fatal Errors (ERR Indicator Flashing)

| Error  | Likely cause and correction  |
|--|--|
| There was a communications error with a component. (See note 1.) | Check whether the communications settings in the components match the settings in the Simple Communications Unit. Correct the settings if necessary. Normal operation will be restored when the cause of the communications error is corrected.  |
|  | Noise can cause communications errors. If noise is suspected, use cables and wiring methods that will reduce noise in the communications lines. Normal operation will be restored when the cause of the communications error is corrected.   |
| Syntax error (See note 2.)                                       | <p>A syntax error occurs when there is an error in the DM settings.</p> <p>When a syntax error is detected, error code "02" is written to the <i>Simple Communications Unit Status (Offset: +1)</i> on page 36) and the DM word address is written to the <i>Syntax Error DM Address word (see Syntax Error DM address (Offset: +2)</i> on page 37).</p> <p>To restore normal operation, correct the setting in the indicated DM word and switch the Unit from RUN to Stop and then back to RUN again. Refer to <i>Simple Communications Unit Control (Offset: +0)</i> on page 36 for details on the RUN/Stop Digit.</p> |

- Note**
1. Details on communications errors can be found in the Response Monitor Area. See *Response Monitor Area (Offset: +0)* on page 46 for details on errors that occur while reading or *Response Monitor Area (Offset: +0)* on page 44 for details on errors that occur while writing.
  2. Syntax errors are indicated in the Simple Communications Unit status word. (Refer to *Simple Communications Unit Status (Offset: +1)* on page 36 for details.)

# SECTION 4

## Allocations in the DM Area

This section describes the interface with the Components provided in the DM Area of the CPU Unit.

- 4-1 Data Memory (DM) Allocation ..... 34
- 4-2 Shared Area..... 35
- 4-3 Individual Unit Areas ..... 41

### 4-1 Data Memory (DM) Allocation

The following diagram shows the usage of the Unit's allocated DM words.

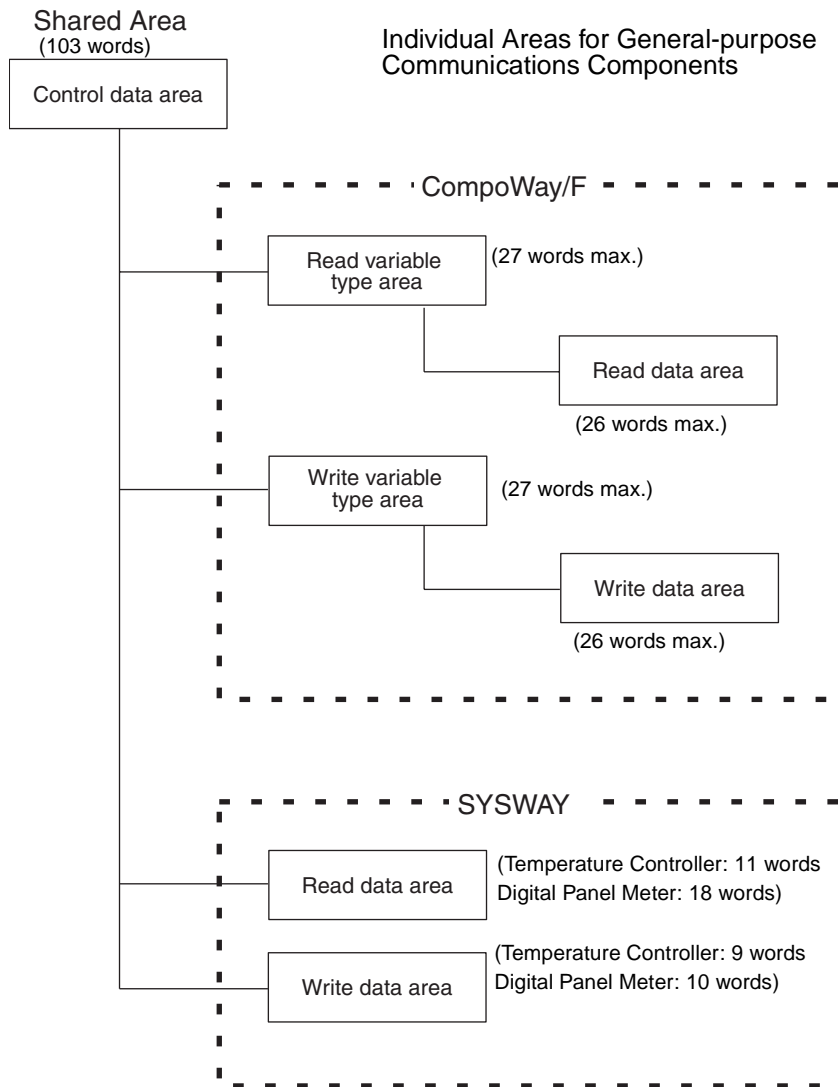

## 4-2 Shared Area

The shared area is used to set and monitor values shared by all of the Units (components).

### Structure of the Control Data Area

The Control Data Area contains 103 words that are used to control operation of the Simple Communications Unit and monitor the Unit's operating status. **Ensure that there are 103 words available for the Control Data Area regardless of the number of connected Units.** The starting DM address is set with DM Starting Address Switch (SW2). Refer to 3. *DM Starting Address Switch (SW2)* on page 13 for details.

**Note** The first word in this area is set using the DM Starting Address Switch (SW2) and the DM Starting Address Area Setting (pins 9 and 10 of SW3). Do not allow the DM Area words used for the Control Data Areas to overlap when more than one Simple Communications Unit is being used.

| Offset | Function   |
|--------|--|
| +0     | Simple Communications Unit control   |
| +1     | Simple Communications Unit status* <sup>1</sup>  |
| +2     | Syntax error DM address* <sup>1</sup>  |
| +3     | Communications control for Units 0 to 7  |
| +4     | Communications control for Units 8 to 15   |
| +5     | Communications control for Units 16 to 23  |
| +6     | Communications control for Units 24 to 31  |
| +7     | Unit 0 communications type   |
| +8     | Starting address of Unit 0 read data area<br>(Starting address of Unit 0 read variable type area* <sup>2</sup> )     |
| +9     | Starting address of Unit 0 write data area<br>(Starting address of Unit 0 write variable type area* <sup>2</sup> )   |
| +10    | Unit 1 communications type   |
| +11    | Starting address of Unit 1 read data area<br>(Starting address of Unit 1 read variable type area* <sup>2</sup> )     |
| +12    | Starting address of Unit 1 write data area<br>(Starting address of Unit 1 write variable type area* <sup>2</sup> )   |
| :      | :  |
| :      | :  |
| +100   | Unit 31 communications type  |
| +101   | Starting address of Unit 31 read data area<br>(Starting address of Unit 31 read variable type area* <sup>2</sup> )   |
| +102   | Starting address of Unit 31 write data area<br>(Starting address of Unit 31 write variable type area* <sup>2</sup> ) |

- Note**
1. These words are used to notify the CPU Unit of the Simple Communications Unit's status.
  2. The functions in parentheses are for CompoWay/F communications.

**Simple Communications Unit Control (Offset: +0)**

| Bits   | Setting                        | Range             | Function   |
|--|--------------------------------|-------------------|--|
| 0 to 3<br>(Digit 16 <sup>0</sup> )                       | RUN/Stop                       | 1: RUN<br>0: Stop | If this digit is set to 1 after the power is turned ON, the Simple Communications Unit will start communications with components and the CPU Unit. (If a fatal error has occurred, the Unit will not start communications with components even if this digit is set to 1.)<br><br>The Simple Communications Unit will not communicate with components if this digit is set to 0. |
| 4 to 7<br>(Digit 16 <sup>1</sup> )                       | Communications timeout         | 0 to 9<br>(BCD)   | Sets the response monitoring time for access from the Simple Communications Unit to connected components. The timeout time is set in multiples of 500 ms ((Set value + 1) × 500 ms). This setting is usually set to 0, which sets a response monitoring time of 500 ms.  |
| 8 to 15<br>(Digits 16 <sup>2</sup> and 16 <sup>3</sup> ) | Number of connected components | 00 to 32<br>(BCD) | Specifies the number of components connected to the Simple Communications Unit. The Simple Communications Unit will not communicate with components if the number of connected components is set to 0.   |

**Simple Communications Unit Status (Offset: +1)**

| Error condition               | Bits  | Setting    | Range            | Function  |
|-------------------------------|---|------------|------------------|---|
| Error occurred<br>(Bit 15 ON) | 0 to 7<br>(Digits 16 <sup>0</sup> and 16 <sup>1</sup> ) | Error code | 01, 02,<br>or 15 | The rightmost 2 digits contain an error code.<br><br>01: Watchdog timer error (fatal error)<br>When this error occurs, the Simple Communications Unit will stop all communications and light the ERR indicator after writing the "Simple Communications Unit Status" word.<br><br>02: Syntax error (non-fatal error)<br>When this error occurs, the Simple Communications Unit will stop communications with the components and flash the ERR indicator after writing the DM address where the error occurred in the "Syntax Error DM Address" word.<br><br>15: DM allocation error (fatal error)<br>This error occurs when the Unit attempts to read or write a DM address that does not exist in the CPU. After the error occurs, the Simple Communications Unit will stop communications with the components and light the ERR indicator.<br>Check the range of the PC's DM area and keep DM allocation within that range. |
|                               | 8 to 11<br>(Digit 16 <sup>2</sup> )                     | Stop flag  | 0                | Operation will stop if an error occurs, and this flag will turn OFF.  |
|                               | 12 to 15<br>(Digit 16 <sup>3</sup> )                    | Error flag | 8                | A value of 8 (bit 15 ON) indicates that a fatal error has occurred in the Simple Communications Unit.   |

| Error condition                   | Bits   | Setting       | Range             | Function  |
|-----------------------------------|--|---------------|-------------------|---|
| No error occurred<br>(Bit 15 OFF) | 0 to 7<br>(Digits 16 <sup>0</sup><br>and 16 <sup>1</sup> ) | Unit number   | 00 to 31<br>(BCD) | Indicates the unit number of the last component with which the communications were completed. The Unit read data from this component and transferred that data to the CPU Unit. These digits contain 00 when the power is first turned ON and communications haven't been completed for any of the components. These digits will also contain 00 in the following cases:<br>1) The "number of connected components" in the Simple Communications Unit Control word (Offset: +0) is set to 00.<br>2) The "RUN/Stop" setting in the Simple Communications Unit Control word (Offset: +0) is set to 00.<br>3) "No Unit connected" is set in the Unit's Communications Type word. |
|                                   | 8 to 11<br>(Digit 16 <sup>2</sup> )                        | Run/Stop flag | 0 or 1            | This flag will be ON when the Simple Communications Unit is running and OFF when it is stopped.   |
|                                   | 12 to 15<br>(Digit 16 <sup>3</sup> )                       | Error flag    | 0                 | A value of 0 (bit 15 OFF) indicates that a fatal error has not occurred in the Simple Communications Unit. The Unit will not be able to notify the CPU Unit that a fatal error has occurred in the following cases:<br>1) The CPU Unit is in RUN mode and DM cannot be written.<br>2) An error occurred in communications with the CPU Unit.<br>3) Program memory is write-protected in the PC Setup (DM 6602).<br><br>When one of these 3 errors error occurs, the Simple Communications Unit will stop all communications and light the ERR indicator.  |

**Syntax Error DM address  
(Offset: +2)**

| Range                 | Function   |
|-----------------------|--|
| 0000 to 9999<br>(BCD) | The Simple Communications Unit indicates the DM address where the syntax error occurred. When two or more syntax errors have been detected, the Unit will indicate the DM address that was detected first. |

**Communications Control  
Bits (Offset: +3, +4, +5,  
and +6)**

| Bit | Offset +3<br>(Units 0 to 7) | Offset +4<br>(Units 8 to 15) | Offset +5<br>(Units 16 to 23) | Offset +6<br>(Units 24 to 31) |
|-----|-----------------------------|------------------------------|-------------------------------|-------------------------------|
| 0   | Unit 7 Read Command Bit     | Unit 15 Read Command Bit     | Unit 23 Read Command Bit      | Unit 31 Read Command Bit      |
| 1   | Unit 7 Write Command Bit    | Unit 15 Write Command Bit    | Unit 23 Write Command Bit     | Unit 31 Write Command Bit     |
| 2   | Unit 6 Read Command Bit     | Unit 14 Read Command Bit     | Unit 22 Read Command Bit      | Unit 30 Read Command Bit      |
| 3   | Unit 6 Write Command Bit    | Unit 14 Write Command Bit    | Unit 22 Write Command Bit     | Unit 30 Write Command Bit     |
| 4   | Unit 5 Read Command Bit     | Unit 13 Read Command Bit     | Unit 21 Read Command Bit      | Unit 29 Read Command Bit      |
| 5   | Unit 5 Write Command Bit    | Unit 13 Write Command Bit    | Unit 21 Write Command Bit     | Unit 29 Write Command Bit     |
| 6   | Unit 4 Read Command Bit     | Unit 12 Read Command Bit     | Unit 20 Read Command Bit      | Unit 28 Read Command Bit      |
| 7   | Unit 4 Write Command Bit    | Unit 12 Write Command Bit    | Unit 20 Write Command Bit     | Unit 28 Write Command Bit     |
| 8   | Unit 3 Read Command Bit     | Unit 11 Read Command Bit     | Unit 19 Read Command Bit      | Unit 27 Read Command Bit      |
| 9   | Unit 3 Write Command Bit    | Unit 11 Write Command Bit    | Unit 19 Write Command Bit     | Unit 27 Write Command Bit     |
| 10  | Unit 2 Read Command Bit     | Unit 10 Read Command Bit     | Unit 18 Read Command Bit      | Unit 26 Read Command Bit      |
| 11  | Unit 2 Write Command Bit    | Unit 10 Write Command Bit    | Unit 18 Write Command Bit     | Unit 26 Write Command Bit     |
| 12  | Unit 1 Read Command Bit     | Unit 9 Read Command Bit      | Unit 17 Read Command Bit      | Unit 25 Read Command Bit      |
| 13  | Unit 1 Write Command Bit    | Unit 9 Write Command Bit     | Unit 17 Write Command Bit     | Unit 25 Write Command Bit     |
| 14  | Unit 0 Read Command Bit     | Unit 8 Read Command Bit      | Unit 16 Read Command Bit      | Unit 24 Read Command Bit      |
| 15  | Unit 0 Write Command Bit    | Unit 8 Write Command Bit     | Unit 16 Write Command Bit     | Unit 24 Write Command Bit     |

| Bit               | Range                                       | Function  |
|-------------------|---|---|
| Write Command Bit | 0: Writing prohibited<br>1: Writing allowed | Setting this bit to 1 allows operation commands and data writes to the component with the corresponding unit number. Data is not written when this bit is set to 0. When an error occurs while writing data, the appropriate error code is written to the write data area's response monitor area. (See <i>Response Monitor Area</i> on page 46 for details.) |
| Read Command Bit  | 0: Reading prohibited<br>1: Reading allowed | Setting this bit to 1 allows data to be read from the component with the corresponding unit number. Data is not read when this bit is set to 0. When an error occurs while reading data, the appropriate error code is written to the read data area's response monitor area. (See <i>Response Monitor Area</i> on page 44 for details.)                      |

**Note** There are restrictions on the number of times data can be written to the Temperature Controller's non-volatile memory. When frequently sending data to a Temperature Controller, either set the Write Command Bit to 0 after writing is completed, or set the write mode for the Temperature Controller to RAM write mode. Also, execute commands to select the RAM write mode and backup mode in only one scan. Some devices will write to non-volatile memory each time the modes are selected, and the life of the non-volatile memory will be exhausted much more quickly if selections are made every scan.

**Unit Communications Type (Offset: +7, +10, +13, ... , +97, and +100)**

Use the following equation to calculate the offset for a given unit number:  

$$\text{Offset} = 7 + (3 \times \text{unit number})$$

| Bits  | Setting                                      | Range         | Function  |
|---|--|---------------|---|
| 0 to 7<br>(Digits 16 <sup>0</sup> and 16 <sup>1</sup> ) | Communications protocol                      | 00, 01, or 02 | Specifies the communications protocol (SYSWAY or CompoWay/F) of the connected component if a component is connected.<br><br>00: No Unit connected<br>01: SYSWAY<br>02: CompoWay/F<br><br>A syntax error will occur and this word's settings will be invalid if a value other than 00, 01, or 02 is specified.   |
| 8 to 11<br>(Digit 16 <sup>2</sup> )                     | Command group (valid with SYSWAY only)       | 1 to 5 (BCD)  | This setting is valid only when SYSWAY (01) is specified for the communications protocol. When SYSWAY is specified, the command group determines which values are read/written when reading or writing data.<br><br>The command group setting will be invalid in the following cases:<br>1) The communications protocol is set to 02 (CompoWay/F).<br>2) The communications protocol is set to 00 (No Unit connected).<br>3) The communications protocol is set to 01 (SYSWAY), but the command group setting is not within the allowed range (1 to 5). |
| 12 to 15<br>(Digit 16 <sup>3</sup> )                    | Segment information (valid with SYSWAY only) | 0, 1, or 2    | This setting is valid only when SYSWAY (01) is specified for the communications protocol. The segment information specifies whether a Temperature Controller or Digital Panel Meter is connected with the SYSWAY protocol.<br><br>The segment information setting will be invalid in the following cases:<br>1) The communications protocol is set to 02 (CompoWay/F).<br>2) The communications protocol is set to 00 (No Unit connected).<br>3) The communications protocol is set to 01 (SYSWAY), but the segment information setting is not 1 or 2.  |

**Note** The command group and segment information settings are valid only when the communications protocol is set to SYSWAY. These settings are not valid when the communications protocol is set to CompoWay/F.

The following table shows the data that will be read and written for each combination of the command group and segment information settings.

| Segment information       | Access                | Data                  | Command group |     |     |     |     |
|---------------------------|-----------------------|-----------------------|---------------|-----|-----|-----|-----|
|                           |                       |                       | 1             | 2   | 3   | 4   | 5   |
| 1: Temperature Controller | Read                  | Present temperature   | YES           | YES | YES | YES | YES |
|                           |                       | Status                | YES           | YES | YES | YES | YES |
|                           |                       | Target temperature    | YES           | YES | YES | YES | YES |
|                           |                       | Alarm 1 SV            | ---           | --- | YES | YES | YES |
|                           |                       | Alarm 2 SV            | ---           | --- | YES | YES | YES |
|                           |                       | Proportional band     | ---           | --- | --- | YES | YES |
|                           |                       | Integral time         | ---           | --- | --- | YES | YES |
|                           |                       | Derivative time       | ---           | --- | --- | YES | YES |
|                           |                       | Heater current        | ---           | --- | --- | --- | YES |
|                           |                       | Heater current status | ---           | --- | --- | --- | YES |
|                           | Write                 | Target temperature    | YES           | YES | YES | YES | YES |
|                           |                       | Operation command     | ---           | YES | YES | YES | YES |
|                           |                       | Alarm 1 SV            | ---           | --- | YES | YES | YES |
|                           |                       | Alarm 2 SV            | ---           | --- | YES | YES | YES |
|                           |                       | Proportional band     | ---           | --- | --- | YES | YES |
|                           |                       | Integral time         | ---           | --- | --- | YES | YES |
| 2: Digital Panel Meter    | Read                  | Display value         | YES           | YES | YES | YES | YES |
|                           |                       | Display value status  | YES           | YES | YES | YES | YES |
|                           |                       | Peak hold             | ---           | YES | YES | --- | YES |
|                           |                       | Peak hold status      | ---           | YES | YES | --- | YES |
|                           |                       | Bottom hold           | ---           | YES | YES | --- | YES |
|                           |                       | Bottom hold status    | ---           | YES | YES | --- | YES |
|                           |                       | Comparison value (HH) | ---           | --- | --- | YES | YES |
|                           |                       | Comparison value (H)  | ---           | --- | --- | YES | YES |
|                           |                       | Comparison value (L)  | ---           | --- | --- | YES | YES |
|                           |                       | Comparison value (LL) | ---           | --- | --- | YES | YES |
| Write                     | Operation command     | ---                   | ---           | YES | --- | YES |     |
|                           | Comparison value (HH) | ---                   | ---           | --- | YES | YES |     |
|                           | Comparison value (H)  | ---                   | ---           | --- | YES | YES |     |
|                           | Comparison value (L)  | ---                   | ---           | --- | YES | YES |     |
|                           | Comparison value (LL) | ---                   | ---           | --- | YES | YES |     |

**Starting Address of Read Data Area or Read Variable Type Area**  
**(Offset: +8, +11, ... , +98, and +101)**

Use the following equation to calculate the offset for a given unit number:  
 $Offset = 8 + (3 \times unit\ number)$

| Setting   | Range                         | Function   |
|---|-------------------------------|--|
| Starting Address of Read Data Area (SYSWAY protocol)              | 0000 to 9999 BCD (DM address) | Specifies the starting DM address in the CPU Unit's DM area where the data read from the component will be stored.<br>A syntax error will occur if the starting address specified in this word is not BCD.   |
| Starting Address of Read Variable Type Area (CompoWay/F protocol) | 0000 to 9999 BCD (DM address) | Specifies the starting DM address of the words that show which variables will be read from the component.<br>The data that will be read from the component is determined by the variable type and address written in the variable type area.<br>A syntax error will occur if the starting address specified in this word is not BCD. |

- Note**
1. Do not specify words within the Control Data Area
  2. When more than one Simple Communications Unit is being used, specify different DM Area words for each.

**Starting Address of Write Data Area or Write Variable Type Area**  
**(Offset: +9, +12, ... , +99, and +102)**

Use the following equation to calculate the offset for a given unit number:  
 $Offset = 9 + (3 \times unit\ number)$

| Setting  | Range                         | Function  |
|--|-------------------------------|---|
| Starting Address of Write Data Area (SYSWAY protocol)              | 0000 to 9999 BCD (DM address) | Specifies the starting DM address in the CPU Unit's DM area containing the data to be written to the component.<br>A syntax error will occur if the starting address specified in this word is not BCD.   |
| Starting Address of Write Variable Type Area (CompoWay/F protocol) | 0000 to 9999 BCD (DM address) | Specifies the starting DM address of the words that show which component variables will be written.<br>The data that will be written to the component is determined by the variable type and address written in the variable type area.<br>A syntax error will occur if the starting address specified in this word is not BCD. |

- Note**
1. Do not specify words within the Control Data Area
  2. When more than one Simple Communications Unit is being used, specify different DM Area words for each.

## 4-3 Individual Unit Areas

The individual Unit areas are used to monitor and set connected components individually. The structure of the individual area is different for CompoWay/F and SYSWAY.

### Area Structure for CompoWay/F Communications

#### Read Variable Type Area (27 words max.)

When CompoWay/F has been specified as the component communications protocol, this “read variable type area” contains the variable type and variable address settings for the SVs and PVs that will be read.

| Offset | Contents                           |
|--------|------------------------------------|
| +0     | Number of read items               |
| +1     | Reserved                           |
| +2     | Starting address of read data area |
| +3     | Variable 1 type                    |
| +4     | Variable 1 address                 |
| +5     | Variable 2 type                    |
| :      | :                                  |
| :      | :                                  |
| +23    | Variable 11 type                   |
| +24    | Variable 11 address                |
| +25    | Variable 12 type                   |
| +26    | Variable 12 address                |

#### Number of Read Items (Offset: +0)

| Range                 | Function  |
|-----------------------|---|
| 0001 to 0012<br>(BCD) | Specify the number of variables that you want to read.<br>For example, the variables set in variable 1 type and variable 2 type will be read if the “number of read items” is set to 0002.<br><br>A syntax error will occur if the number of items specified in this word is not between 0001 and 0012 BCD. |

#### Reserved (Offset: +1)

| Range | Function                      |
|-------|-------------------------------|
| 0000  | Always set this word to 0000. |

#### Starting Address of Read Data Area (Offset: +2)

| Range                 | Function   |
|-----------------------|--|
| 0000 to 9999<br>(BCD) | Specifies the starting DM address in the CPU Unit's DM area where the data read from the component will be stored. |

- Note**
1. Do not specify words within the Control Data Area
  2. When more than one Simple Communications Unit is being used, specify different DM Area words for each.

**Variable Types (Offset: +3, +5, ... , +23, and +25)**

Use the following equation to calculate the offset for a given variable number:

$$\text{Offset} = 1 + (2 \times \text{variable number})$$

| Range                 | Function   |
|-----------------------|--|
| 00C0 to 00CF<br>(Hex) | Sets the type of variable data that you want to read.<br>The variable types are predetermined in each component, so refer to the component's manual to find the actual variable type.<br>A syntax error will occur if the variable type specified in this word is not between 00C0 and 00CF Hex. |

**Note** Depending on the Component, some variable types will not be written unless the variable type is changed. Refer to the component's manual for details.

**Variable Addresses (Offset: +4, +6, ... , +24, and +26)**

Use the following equation to calculate the offset for a given variable number:

$$\text{Offset} = 2 + (2 \times \text{variable number})$$

| Range                 | Function  |
|-----------------------|---|
| 0000 to FFFF<br>(Hex) | Sets the variable address of the data that you want to read.<br>The variable addresses are predetermined in each component, so refer to the component's manual to find the actual variable address. |

**Write Variable Type Area  
(27 words max.)**

When CompoWay/F has been specified as the component communications protocol, this "write variable type area" contains the variable type and variable address settings for the SVs that will be written.

| Offset | Contents                            |
|--------|-------------------------------------|
| +0     | Number of write items               |
| +1     | Operation command                   |
| +2     | Starting address of write data area |
| +3     | Variable 1 type                     |
| +4     | Variable 1 address                  |
| +5     | Variable 2 type                     |
| :      | :                                   |
| :      | :                                   |
| +23    | Variable 11 type                    |
| +24    | Variable 11 address                 |
| +25    | Variable 12 type                    |
| +26    | Variable 12 address                 |

**Number of Write Items (Offset: +0)**

| Range                 | Function  |
|-----------------------|---|
| 0000 to 0012<br>(BCD) | Specify the number of variables that you want to write.<br>For example, the variables set in variable 1 type and variable 2 type will be written if the "number of write items" is set to 0002.<br>Variables will not be written if the "number of write items" is set to 0000; in this case, only the operation command is valid.<br>A syntax error will occur if the number of items specified in this word is not between 0000 and 0012 BCD. |

**Operation Command (Offset: +1)**

| Range        | Function  |
|--------------|---|
| 0000 or 0001 | The write data area's operation command is disabled when 0000 is specified.<br>The write data area's operation command is enabled to the component when 0001 is specified.<br>A syntax error will occur if the Operation Command is not 0000 or 0001. |

**Note** There are restrictions on the number of times data can be written to the Temperature Controller's non-volatile memory. When frequently sending data to a Temperature Controller, either set the Write Command Bit to 0 after writing is completed, or set the write mode for the Temperature Controller to RAM write mode. Also, execute commands to select the RAM write mode and backup mode in only one scan. Some devices will write to non-volatile memory each time the modes are selected, and the life of the non-volatile memory will be exhausted much more quickly if selections are made every scan.

**Starting Address of Write Data Area (Offset: +2)**

| Range              | Function   |
|--------------------|--|
| 0000 to 9999 (BCD) | Specifies the starting DM address in the CPU Unit's DM area containing the data that you want to write to the component. |

- Note**
1. Do not specify words within the Control Data Area
  2. When more than one Simple Communications Unit is being used, specify different DM Area words for each.

**Variable Types (Offset: +3, +5, ... , +23, and +25)**

Use the following equation to calculate the offset for a given variable number:  
 $Offset = 1 + (2 \times \text{variable number})$

| Range              | Function  |
|--------------------|---|
| 00C0 to 00CF (Hex) | Sets the type of variable data that you want to write.<br>The variable types are predetermined in each component, so refer to the component's manual to find the actual variable type.<br>A syntax error will occur if the variable type specified in this word is not between 00C0 and 00CF Hex. |

- Note**
1. Do not specify words within the Control Data Area
  2. When more than one Simple Communications Unit is being used, specify different DM Area words for each.
  3. Depending on the Component, some variable types will not be written unless the variable type is changed. Refer to the component's manual for details.

**Variable Addresses (Offset: +4, +6, ... , +24, and +26)**

Use the following equation to calculate the offset for a given variable number:  
 $Offset = 2 + (2 \times \text{variable number})$

| Range              | Function   |
|--------------------|--|
| 0000 to FFFF (Hex) | Sets the variable address of the data that you want to write.<br>The variable addresses are predetermined in each component, so refer to the component's manual to find the actual variable address. |

**Read Data Area  
(26 words max.)**

The starting address of the “read data area” is specified in the “read variable type area.” This “read data area” stores the variable data read from the component.

| Offset | Contents                            |
|--------|-------------------------------------|
| +0     | Response monitor                    |
| +1     | Component status                    |
| +2     | Variable 1 read data (lower bytes)  |
| +3     | Variable 1 read data (upper bytes)  |
| +4     | Variable 2 read data (lower bytes)  |
| +5     | Variable 2 read data (upper bytes)  |
| :      | :                                   |
| :      | :                                   |
| +22    | Variable 11 read data (lower bytes) |
| +23    | Variable 11 read data (upper bytes) |
| +24    | Variable 12 read data (lower bytes) |
| +25    | Variable 12 read data (upper bytes) |

**Response Monitor Area (Offset: +0)**

This area contains the results of communications when communicating with the component to read variables.

1,2,3...

1. End Code = 00

When the function’s end code is 00, the “response monitor area” contains the response code.

| Response code | Meaning  |
|---------------|--|
| 0000          | Indicates normal completion.                     |
| 0401          | Unsupported command                              |
| 1001          | Command length too long                          |
| 1002          | Command length too short                         |
| 1101          | Area type error                                  |
| 1103          | Starting address out-of-range error              |
| 1104          | End address out-of-range error                   |
| 1003          | Number of elements doesn’t match amount of data. |
| 110B          | Response length too long                         |
| 1100          | Parameter error                                  |
| 2203          | Operating error                                  |

2. End Code ≠ 00

When an error occurs and the function’s end code is a value other than 00, the “response monitor area” contains the end code (error code). The value of FF in the first two digits indicates that an error occurred during transmission of the CompoWay/F command.

| Error code | Meaning                    |
|------------|----------------------------|
| FF04       | Address overflow           |
| FF0D       | Could not execute command. |
| FF10       | Parity error               |
| FF11       | Framing error              |
| FF12       | Overrun error              |
| FF13       | BCC error                  |
| FF14       | Format error               |
| FF15       | Numeric data error         |
| FF16       | Sub-address error          |

| Error code | Meaning                 |
|------------|-------------------------|
| FF18       | Frame length error      |
| FF97       | Response data BCC error |

3. Timeout error occurred.

| Timeout code | Meaning  |
|--------------|--|
| E999         | Indicates that there was no response from the component. |

**Component Status (Offset: +1)**

| 16 <sup>3</sup>                                 | 16 <sup>2</sup> | 16 <sup>1</sup> | 16 <sup>0</sup> |
|---|-----------------|-----------------|-----------------|
| Component status                                |                 |                 |                 |
| Contain the controller status of the component. |                 |                 |                 |

**Read Data (Offset: +2, +4, ... , +22, and +24)**

The read data is contained in two words starting at offset 2 × n (n = variable number.)

| Offset                               | Range                 | Function  |
|--------------------------------------|-----------------------|---|
| 2 × n<br>(n = variable number)       | 0000 to FFFF<br>(Hex) | Contains the lower (rightmost) two bytes of the data. |
| (2 × n) + 1<br>(n = variable number) | 0000 to FFFF<br>(Hex) | Contains the upper (leftmost) two bytes of the data.  |

The variable data read from a component can have a value ranging from 0000 0000 to FFFF FFFF. The read data will be 0000 0000 if a communications error occurred. The following example shows the contents of the read data area when a communications error occurred while reading the variable 2 read data.

- Response Monitor Area: Contains the error code.
- Status: Contains the controller status.
- Read data 1: Contains the data read from the component.
- Read data 2: Contains 0000 0000.
- Remaining read items: Contain 0000 0000.

- Note**
1. The decimal point position has to be managed by the user since the component's decimal point position is not transferred in CompoWay/F communications.
  2. BCD format is used with Digital Panel Meters (K3N□). For details, refer to the manual for the model used.

**Write Data Area  
(26 words max.)**

The starting address of the “write data area” is specified in the “write variable type area.” Store the variable data that you want to write to the component in this “write data area.”

| Offset | Contents                              |
|--------|---------------------------------------|
| +0     | Response monitor                      |
| +1     | Operation Command                     |
| +2     | Variable 1 write data (lower 2 bytes) |
| +3     | Variable 1 write data (upper 2 bytes) |
| +4     | Variable 2 write data (lower 2 bytes) |
| +5     | Variable 2 write data (upper 2 bytes) |
| :      | :                                     |
| :      | :                                     |

| Offset | Contents                               |
|--------|--|
| +22    | Variable 11 write data (lower 2 bytes) |
| +23    | Variable 11 write data (upper 2 bytes) |
| +24    | Variable 12 write data (lower 2 bytes) |
| +25    | Variable 12 write data (upper 2 bytes) |

**Response Monitor Area (Offset: +0)**

This area contains the results of communications when communicating with the component to write variables.

1,2,3...

1. End Code = 00

When the function's end code is 00, the "response monitor area" contains the response code.

| Response code | Meaning  |
|---------------|--|
| 0000          | Indicates normal completion.                     |
| 0401          | Unsupported command                              |
| 1001          | Command length too long                          |
| 1002          | Command length too short                         |
| 1101          | Area type error                                  |
| 1103          | Starting address out-of-range error              |
| 1104          | End address out-of-range error                   |
| 1003          | Number of elements doesn't match amount of data. |
| 110B          | Response length too long                         |
| 1100          | Parameter error                                  |
| 3003          | Read-only error                                  |
| 2203          | Operating error                                  |

2. End Code  $\neq$  00

When an error occurs and the function's end code is a value other than 00, the "response monitor area" contains the end code (error code). The value of FF in the first two digits indicates that an error occurred during transmission of the CompoWay/F command.

| Error code | Meaning                         |
|------------|---------------------------------|
| FF04       | Address overflow                |
| FF0D       | Could not execute command.      |
| FF10       | Parity error                    |
| FF11       | Framing error                   |
| FF12       | Overrun error                   |
| FF13       | BCC error                       |
| FF14       | Format error                    |
| FF15       | Numeric data error              |
| FF16       | Sub-address error               |
| FF18       | Frame length error              |
| FF21       | Non-volatile memory write error |
| FF97       | Response data BCC error         |

3. Timeout error occurred

| Timeout code | Meaning  |
|--------------|--|
| E999         | Indicates that there was no response from the component. |

**Operation Command (Offset: +1)**

Refer to the component's Operation Manual for details on the command codes for the various CompoWay/F communications functions.

| Bits                                   | Function   |
|--|--|
| 0 to 7<br>(Digits $16^0$ and $16^1$ )  | Related information<br>Set any related information required by the CompoWay/F command code as described in the component's manual. |
| 8 to 15<br>(Digits $16^2$ and $16^3$ ) | Command code<br>Set the CompoWay/F command code as described in the component's manual.  |

- Note**
- SVs cannot be written in a scan in which 0600 has been specified for the command code and related information.
  - Execute commands to select the RAM write mode and backup mode in only one scan. Some devices will write to non-volatile memory each time the modes are selected, and the life of the non-volatile memory will be exhausted much more quickly if selections are made every scan.

**Write Data (Offset: +2, +4, ... , +22, and +24)**

The write data is contained in two words starting at offset  $2 \times n$  ( $n$  = variable number.)

| Offset   | Range                 | Function  |
|--|-----------------------|---|
| $2 \times n$<br>( $n$ = variable number)       | 0000 to FFFF<br>(Hex) | Store the lower (rightmost) two bytes of the SV data that you want to write to the corresponding component. |
| $(2 \times n) + 1$<br>( $n$ = variable number) | 0000 to FFFF<br>(Hex) | Store the upper (leftmost) two bytes of the SV data that you want to write to the corresponding component.  |

If a communications error occurs, the write operation that is in progress will be stopped and the next process will be performed for the general-purpose communications device.

The following example shows the results of the write operation when a communications error occurred while writing variable 2.

- Response Monitor Area: Contains the error code.
- Operation Command: The operation command won't be executed.
- Variable 1 write data: The SV will be written normally.
- Variable 2 write data: The SV won't be written.
- Remaining write items: SVs won't be written.

- Note**
- The decimal point position has to be managed by the user since the component's decimal point position is not transferred in CompoWay/F communications.
  - BCD format is used with Digital Panel Meters (K3N□). For details, refer to the manual for the model used.

## Area Structure for SYSWAY Communications

### Read Data Area: Temperature Controllers (11 words)

The following data will be read from a Temperature Controller when SYSWAY has been specified as the component communications protocol.

The starting address of the “read data area” is specified in the “Control Data Area.” Select any one of the 5 command groups to specify which PVs and SVs will be read, although 11 DM words will be allocated to the read data area regardless of the command group selected.

| Offset | Data                   | Command group |      |      |      |      |
|--------|------------------------|---------------|------|------|------|------|
|        |                        | 1             | 2    | 3    | 4    | 5    |
| +0     | Response monitor       | Read          | Read | Read | Read | Read |
| +1     | Present temperature    | Read          | Read | Read | Read | Read |
| +2     | Status                 | Read          | Read | Read | Read | Read |
| +3     | Target temperature     | Read          | Read | Read | Read | Read |
| +4     | Alarm 1 SV             | ---           | ---  | Read | Read | Read |
| +5     | Alarm 2 SV             | ---           | ---  | Read | Read | Read |
| +6     | Proportional band      | ---           | ---  | ---  | Read | Read |
| +7     | Integral time          | ---           | ---  | ---  | Read | Read |
| +8     | Derivative time        | ---           | ---  | ---  | Read | Read |
| +9     | Heater current monitor | ---           | ---  | ---  | ---  | Read |
| +10    | Heater current status  | ---           | ---  | ---  | ---  | Read |

### Response Monitor Area (Offset: +0)

The structure of the response monitor area is the same whether SYSWAY or CompoWay/F communications are used. See *Response Monitor Area* on page 44 for details on the response monitor area.

### Read Data (Offset: +1, +3, +4, +5, +6, +7, +8, and +9)

Each word of data read from the Temperature Controller has a value ranging from 0000 to FFFF. Negative values are expressed as their 2's complement. The word will contain 0000 if a communications error occurred. The following example shows the contents of the read data when a communications error occurred while reading the target temperature in command group 1.

- Response Monitor Area: Contains the error code.
- Present temperature: Contains data read from Temperature Controller.
- Status: Contains status read from Temperature Controller.
- Target temperature: Contains 0000.

**Note** The decimal point position has to be managed by the user since the Temperature Controller's decimal point position is not transferred in SYSWAY (X format) communications.

### Status (Offset: +2 and +10)

The read data area's +2 offset word contains the status when reading the present temperature. The +10 offset word contains the heater current status when reading the heater current. Refer to the Temperature Controller's Operation Manual for details on the status values.

**Read Data Area:  
Digital Panel Meters  
(18 words)**

The following data will be read from a Digital Panel Meter when SYSWAY has been specified as the component communications protocol.

The starting address of the “read data area” is specified in the “Control Data Area.” Select any one of the 5 command groups to specify which PVs and SVs will be read, although 18 DM words will be allocated to the read data area regardless of the command group selected.

| Offset      | Data                  | Command group |      |      |      |      |
|-------------|-----------------------|---------------|------|------|------|------|
|             |                       | 1             | 2    | 3    | 4*   | 5    |
| +0          | Response monitor area | Read          | Read | Read | Read | Read |
| +1 and +2   | Display value         | Read          | Read | Read | Read | Read |
| +3          | Display value status  | Read          | Read | Read | Read | Read |
| +4 and +5   | Peak hold             | ---           | Read | Read | ---  | Read |
| +6          | Peak hold status      | ---           | Read | Read | ---  | Read |
| +7 and +8   | Bottom hold           | ---           | Read | Read | ---  | Read |
| +9          | Bottom hold status    | ---           | Read | Read | ---  | Read |
| +10 and +11 | Comparison value (HH) | ---           | ---  | ---  | Read | Read |
| +12 and +13 | Comparison value (H)  | ---           | ---  | ---  | Read | Read |
| +14 and +15 | Comparison value (L)  | ---           | ---  | ---  | Read | Read |
| +16 and +17 | Comparison value (LL) | ---           | ---  | ---  | Read | Read |

**Note** When command group 4 is selected, words with offsets +4 through +9 will be cleared to 0000.

**Response Monitor Area (Offset: +0)**

The structure of the response monitor area is the same whether SYSWAY or CompoWay/F communications are used. See *Response Monitor Area* on page 44 for details on the response monitor area.

**Read Data**

|                                      |  |                 |                 |                 |
|--------------------------------------|--|-----------------|-----------------|-----------------|
| Offsets:<br>+1, 4, 7, 10, 12, 14, 16 | 16 <sup>3</sup>  | 16 <sup>2</sup> | 16 <sup>1</sup> | 16 <sup>0</sup> |
|                                      | Read data lower byte (Binary, negative values are expressed as their 2's complement) |                 |                 |                 |
|                                      | 0000 to FFFF Hex   |                 |                 |                 |
| Offsets:<br>+2, 5, 8, 11, 13, 15, 17 | 16 <sup>3</sup>  | 16 <sup>2</sup> | 16 <sup>1</sup> | 16 <sup>0</sup> |
|                                      | Read data upper byte (Binary, negative values are expressed as their 2's complement) |                 |                 |                 |
|                                      | 0000 to FFFF Hex   |                 |                 |                 |

Each two-word value read from the Digital Panel Meter has a value ranging from 0000 0000 to FFFF FFFF signed binary data. Negative values are expressed as their 2's complement. The words will contain 0000 0000 if a communications error occurred. The following example shows the contents of the read data area when a communications error occurred while reading the display value in command group 1.

- Response Monitor Area: Contains the error code.
- Display value: Contains 0000 0000.
- Display value status: Contains 0000.

**Note** The decimal point position has to be managed by the user since the Digital Panel Meter's decimal point position is not transferred in SYSWAY (X format) communications.

**Status (Offset: +3, +6, and +9)**

The read data area's +3, +6, and +9 offset words contain the status when reading the display value, peak hold value, or bottom hold value, respectively.

Refer to the Digital Panel Meter's Operation Manual for details on the status values.

**Write Data Area:  
Temperature Controllers  
(9 words)**

The following data will be written to a Temperature Controller when SYSWAY has been specified as the component communications protocol.

The starting address of the "write data area" is specified in the "Control Data Area." Select any one of the 5 command groups to specify which SVs will be written, although 9 DM words will be allocated to the write data area regardless of the command group selected.

| Offset | Data                           | Command group |         |         |         |         |
|--------|--------------------------------|---------------|---------|---------|---------|---------|
|        |                                | 1             | 2       | 3       | 4       | 5       |
| +0     | Response monitor area          | Written       | Written | Written | Written | Written |
| +1     | Target temperature             | Written       | Written | Written | Written | Written |
| +2     | Operation command              | ---           | Written | Written | Written | Written |
| +3     | Alarm 1 SV                     | ---           | ---     | Written | Written | Written |
| +4     | Alarm 2 SV                     | ---           | ---     | Written | Written | Written |
| +5     | Proportional band              | ---           | ---     | ---     | Written | Written |
| +6     | Integral time                  | ---           | ---     | ---     | Written | Written |
| +7     | Derivative time                | ---           | ---     | ---     | Written | Written |
| +8     | Heater burnout detection value | ---           | ---     | ---     | ---     | Written |

**Response Monitor Area (Offset: +0)**

The structure of the response monitor area is the same whether SYSWAY or CompoWay/F communications are used. See *Response Monitor Area* on page 46 for details on the response monitor area.

**Write Data (Offset: +1, +3, +4, +5, +6, +7, and +8)**

Set the words of data to be written to the Temperature Controller as binary data. Negative values are expressed as their 2's complement.

If a communications error occurs while writing data, the remaining write data will not be written and the next process for the general-purpose communications device will be executed. The error code will be written to the response monitor area.

The following example shows the results of the write operation when a communications error occurred while writing the target temperature in command group 2.

- Response Monitor Area: Contains the error code.
- Target temperature: The SV won't be written.
- Operation Command: The operation command won't be written.

**Note** The decimal point position has to be managed by the user since the Temperature Controller's decimal point position is not transferred in SYSWAY (X format) communications.

**Operation Command (Offset: +2)**

Store the operation command code (0000 to 0005) in this word. When a command group that includes the operation command is selected, the corresponding operation command will be sent to the Temperature Controller.

| Command code | Operation                                       |
|--------------|---|
| 0000         | Don't perform operation command. (No operation) |
| 0001         | Stop auto-tuning.                               |
| 0002         | Start auto-tuning.                              |
| 0003         | Select backup mode.                             |

| Command code | Operation               |
|--------------|-------------------------|
| 0004         | Select RAM write mode.  |
| 0005         | Save the Run/Adjust SV. |

- Note**
- SVs cannot be written in a scan in which “start auto-tuning” has been specified.
  - Starting and stopping auto-tuning is possible for E5EK, E5AK, and E5AF models only.
  - There are restrictions on the number of times data can be written to the Temperature Controller’s non-volatile memory. When frequently sending data to a Temperature Controller, either set the Write Command Bit to 0 after writing is completed, or set the write mode for the Temperature Controller to RAM write mode. Also, execute commands to select the RAM write mode and backup mode in only one scan. Some devices will write to non-volatile memory each time the modes are selected, and the life of the non-volatile memory will be exhausted much more quickly if selections are made every scan.

**Write Data Area:  
Digital Panel Meters  
(10 words)**

The following data will be written to a Digital Panel Meter when SYSWAY has been specified as the component communications protocol.

The starting address of the “write data area” is specified in the “Control Data Area.” Select any one of the 5 command groups to specify which SVs will be written, although 10 DM words will be allocated to the write data area regardless of the command group selected.

| Offset    | Data                  | Command group |         |         |         |         |
|-----------|-----------------------|---------------|---------|---------|---------|---------|
|           |                       | 1             | 2       | 3       | 4       | 5       |
| +0        | Response monitor area | Written       | Written | Written | Written | Written |
| +1        | Operation command     | ---           | ---     | Written | ---     | Written |
| +2 and +3 | Comparison value (HH) | ---           | ---     | ---     | Written | Written |
| +4 and +5 | Comparison value (H)  | ---           | ---     | ---     | Written | Written |
| +6 and +7 | Comparison value (L)  | ---           | ---     | ---     | Written | Written |
| +8 and +9 | Comparison value (LL) | ---           | ---     | ---     | Written | Written |

**Response Monitor Area (Offset: +0)**

The structure of the response monitor area is the same whether SYSWAY or CompoWay/F communications are used. See *Response Monitor Area* on page 46 for details on the response monitor area.

**Write Data**

|                         |   |        |        |        |
|-------------------------|---|--------|--------|--------|
| Offsets:<br>+2, 4, 6, 8 | $16^3$  | $16^2$ | $16^1$ | $16^0$ |
|                         | Write data lower byte (Binary, negative values are expressed as their 2’s complement) |        |        |        |
|                         | 0000 to FFFF Hex  |        |        |        |
| Offsets:<br>+3, 5, 7, 9 | $16^3$  | $16^2$ | $16^1$ | $16^0$ |
|                         | Write data upper byte (Binary, negative values are expressed as their 2’s complement) |        |        |        |
|                         | 0000 to FFFF Hex  |        |        |        |

Set the words of data to be written to the Digital Panel Meter as binary data. Negative values are expressed as their 2’s complement.

If a communications error occurs while writing data, the remaining write data will not be written and the next process for the general-purpose communications device will be executed. The error code will be written to the response monitor area.

The following example shows the results of the write operation when a communications error occurred while writing comparison value (H) in command group 4.

- Response Monitor Area: Contains the error code.
- Comparison value (HH): The SV will be written normally.
- Comparison value (H): The SV won't be written.
- Comparison value (L): The SV won't be written.
- Comparison value (LL): The SV won't be written.

**Note** The decimal point position has to be managed by the user since the Digital Panel Meter's decimal point position is not transferred in SYSWAY (X format) communications.

#### Operation Command (Offset: +2)

Store the operation command code (0000 to 0004) in this word. When a command group that includes the operation command is selected, the corresponding operation command will be sent to the Digital Panel Meter.

| Command code | Operation                                       |
|--------------|---|
| 0000         | Don't perform operation command. (No operation) |
| 0001         | Reset.  |
| 0002         | Select backup mode.                             |
| 0003         | Select RAM write mode.                          |
| 0004         | Save the Setting/Adjust values.                 |

**Note** There are restrictions on the number of times data can be written to the Temperature Controller's non-volatile memory. When frequently sending data to a Temperature Controller, either set the Write Command Bit to 0 after writing is completed, or set the write mode for the Temperature Controller to RAM write mode. Also, execute commands to select the RAM write mode and backup mode in only one scan. Some devices will write to non-volatile memory each time the modes are selected, and the life of the non-volatile memory will be exhausted much more quickly if selections are made every scan.

# Appendix A

## Data Refresh Cycle (Reference Data)

### Data Refresh Cycle

The following table shows the refresh between data refreshes for various communications conditions for a CJ-series CPU Unit. The actual cycle depends upon the system configuration and size of the user program, so these values are given only as guidelines.

| Communications protocol | Number of components | Baud rates (bps) Host/components | Read data items | Write data items | Command group | Refresh cycle |       |      |
|-------------------------|----------------------|----------------------------------|-----------------|------------------|---------------|---------------|-------|------|
| CompoWay/F              | 16                   | 9,600/9,600                      | 12 × 16 = 192   | 12 × 16 = 192    | ---           | 50 s          |       |      |
|                         |                      |                                  | 12 × 16 = 192   | ---              | ---           | 26 s          |       |      |
|                         |                      |                                  | ---             | 1 × 16 = 16      | ---           | 6 s           |       |      |
|                         |                      | 19,200/19,200                    | 12 × 16 = 192   | 12 × 16 = 192    | ---           | ---           | 33 s  |      |
|                         |                      |                                  | 12 × 16 = 192   | ---              | ---           | 17 s          |       |      |
|                         |                      |                                  | 1 × 16 = 16     | ---              | ---           | 4 s           |       |      |
|                         |                      |                                  | ---             | 1 × 16 = 16      | ---           | 4 s           |       |      |
|                         |                      |                                  | 57,600/19,200   | 12 × 16 = 192    | 12 × 16 = 192 | ---           | ---   | 30 s |
|                         |                      |                                  |                 | 12 × 16 = 192    | ---           | ---           | 15 s  |      |
|                         |                      | 1 × 16 = 16                      |                 | ---              | ---           | 3 s           |       |      |
|                         |                      | 8                                | 19,200/38,400   | 12 × 8 = 96      | 12 × 8 = 96   | ---           | 14 s  |      |
|                         |                      |                                  |                 | 12 × 8 = 96      | ---           | ---           | 7 s   |      |
|                         | 1 × 8 = 8            |                                  |                 | ---              | ---           | 2 s           |       |      |
|                         | 57,600/38,400        |                                  |                 | 12 × 8 = 96      | 12 × 8 = 96   | ---           | 12 s  |      |
|                         |                      |                                  |                 | 12 × 8 = 96      | ---           | ---           | 6 s   |      |
|                         |                      |                                  |                 | 1 × 8 = 8        | ---           | ---           | 1.5 s |      |
|                         | 4                    |                                  | 9,600/9,600     | 1 × 4 = 4        | ---           | ---           | 2 s   |      |
|                         |                      |                                  |                 | 1 × 4 = 4        | ---           | ---           | 1 s   |      |
|                         |                      |                                  |                 | ---              | 1 × 4 = 4     | ---           | 1 s   |      |
|                         |                      |                                  | 57,600/38,400   | 1 × 4 = 4        | ---           | ---           | 1 s   |      |
|                         |                      |                                  |                 | 16               | 9,600/9,600   | Yes           | Yes   | 4    |
| Yes                     |                      |                                  |                 |                  |               | No            | 4     | 10 s |
| No                      | Yes                  | 1                                | 3 s             |                  |               |               |       |      |
| 19,200/19,200           | Yes                  | Yes                              | 4               |                  | 14 s          |               |       |      |
|                         | Yes                  | No                               | 4               |                  | 7 s           |               |       |      |
|                         | No                   | Yes                              | 1               |                  | 2 s           |               |       |      |
| 57,600/19,200           | Yes                  | Yes                              | 4               |                  | 13 s          |               |       |      |
|                         | Yes                  | Yes                              | 1               |                  | 4 s           |               |       |      |
|                         | Yes                  | No                               | 1               |                  | 2 s           |               |       |      |
|                         | No                   | Yes                              | 4               | 6 s              |               |               |       |      |
| 4                       | 9,600/9,600          | No                               | No              | 1                | 1 s           |               |       |      |
|                         |                      | Yes                              | No              | 1                | 1 s           |               |       |      |
|                         | 19,200/19,200        | No                               | Yes             | 1                | 1 s           |               |       |      |
|                         |                      | Yes                              | No              | 4                | 2 s           |               |       |      |
|                         |                      | Yes                              | No              | 1                | 1 s           |               |       |      |
| 57,600/19,200           | Yes                  | No                               | 4               | 2 s              |               |               |       |      |
|                         | Yes                  | No                               | 1               | 1 s              |               |               |       |      |

- Note 1. The refresh cycle is not fixed because the communications response times of the components and the CPU Unit are not fixed. The refresh cycles shown in the table above are average times.
2. The number of read data items and number of write data items for SYSWAY communications are determined by the command group that has been selected.

## Calculating Data Refresh Cycles

The following formulas can be used to calculate the data refresh cycles. The actual cycle depends upon the system configuration and size of the user program, so these formulas are given only as guidelines.

### CompoWay/F

Data refresh cycle (Td) =

Tps + (Tcr1 × No. of read components) + Component read time + (Tcw1 × No. of write components) + Component write time + (Tcrw × No. of read/write components) + Component read/write time [seconds]

Component read time = Tcr2 × (No. of read items – 1) + Tcr2 × (No. of read items – 1) + ..... +  
Tcr2 × (No. of read items – 1)  
(For each Component being read)

Component write time = Tcw2 × (No. of write items – 1) + Tcw2 × (No. of write items – 1) + ..... +  
Tcw2 × (No. of write items – 1)  
(For each Component being written)

Component read/write time =

Tcr2 × (No. of read items – 1) + Tcw2 × (No. of write items – 1) +  
Tcr2 × (No. of read items – 1) + Tcw2 × (No. of write items – 1) + ..... +  
Tcr2 × (No. of read items – 1) + Tcw2 × (No. of write items – 1)  
(For each Component being read/written)

### CJ-series CPU Units

| Baud rates (bps)<br>Host/components | Tps  | Tcr1 | Tcr2 | Tcw1 | Tcw2 | Tcrw |
|-------------------------------------|------|------|------|------|------|------|
| 9600/9600                           | 0.19 | 0.36 | 0.11 | 0.33 | 0.11 | 0.69 |
| 19200/19200                         | 0.12 | 0.24 | 0.07 | 0.21 | 0.08 | 0.45 |
| 19200/38400                         | 0.13 | 0.21 | 0.06 | 0.20 | 0.06 | 0.41 |
| 57600/19200                         | 0.07 | 0.19 | 0.07 | 0.15 | 0.07 | 0.34 |
| 57600/38400                         | 0.08 | 0.16 | 0.05 | 0.13 | 0.05 | 0.30 |

### CS-series CPU Units

| Baud rates (bps)<br>Host/components | Tps  | Tcr1 | Tcr2 | Tcw1 | Tcw2 | Tcrw |
|-------------------------------------|------|------|------|------|------|------|
| 9600/9600                           | 0.19 | 0.35 | 0.10 | 0.33 | 0.10 | 0.67 |
| 19200/19200                         | 0.12 | 0.23 | 0.07 | 0.21 | 0.07 | 0.45 |
| 19200/38400                         | 0.13 | 0.21 | 0.05 | 0.20 | 0.05 | 0.41 |
| 57600/19200                         | 0.07 | 0.19 | 0.06 | 0.16 | 0.06 | 0.34 |
| 57600/38400                         | 0.09 | 0.17 | 0.05 | 0.14 | 0.05 | 0.31 |

### CQM1H CPU Unit

| Baud rates (bps)<br>Host/components | Tps  | Tcr1 | Tcr2 | Tcw1 | Tcw2 | Tcrw |
|-------------------------------------|------|------|------|------|------|------|
| 9600/9600                           | 0.17 | 0.35 | 0.12 | 0.32 | 0.12 | 0.68 |
| 19200/19200                         | 0.10 | 0.23 | 0.08 | 0.20 | 0.08 | 0.42 |
| 19200/38400                         | 0.11 | 0.20 | 0.07 | 0.18 | 0.06 | 0.38 |

**CPM2A CPU Unit**

| Baud rates (bps)<br>Host/components | Tps  | Tcr1 | Tcr2 | Tcw1 | Tcw2 | Tcrw |
|-------------------------------------|------|------|------|------|------|------|
| 9600/9600                           | 0.15 | 0.34 | 0.12 | 0.30 | 0.12 | 0.63 |
| 19200/19200                         | 0.08 | 0.21 | 0.07 | 0.17 | 0.08 | 0.38 |
| 19200/38400                         | 0.08 | 0.18 | 0.06 | 0.16 | 0.06 | 0.34 |

Example: The following calculations are for a CJ-series CPU Unit with a 57,600 baud rate to the host, a 38,400 baud rate to the components, and eight E5ZN components. For four of the components (group 1), 2 words are read and for the other four components (group 2), 2 words are read and 1 word is written.

Data refresh cycle (Td)

$$\begin{aligned}
 &= [\text{Time for group 1}] + [\text{Time for group 2}] \\
 &= [\text{Tps} + (\text{Tcr1} \times 4) + (\text{Tcr2} \times (2 - 1)) \times 4] + [(\text{Tcrw} \times 4) + (\text{Tcr2} \times (2 - 1)) + (\text{Tcw2} \times (1 - 1)) \times 4] \\
 &= [0.08 + (0.16 \times 4) + (0.05 \times (2 - 1)) \times 4] + [(0.30 \times 4) + (0.05 \times (2 - 1)) \times 4] \\
 &= 2.32 \\
 \text{Td} &= 2.3 \text{ s}
 \end{aligned}$$

**SYSWAY**

Data refresh cycle (Td) =

$$\begin{aligned}
 &\text{Tps} + \text{Tsr1} \times \text{No. of read Components for command group 1} + \text{Tsw1} \times \text{No. of write Components for command group 1} \\
 &+ \text{Tsr2} \times \text{No. of read Components for command group 2} + \text{Tsw2} \times \text{No. of write Components for command group 2} \\
 &+ \text{Tsr3} \times \text{No. of read Components for command group 3} + \text{Tsw3} \times \text{No. of write Components for command group 3} \\
 &+ \text{Tsr4} \times \text{No. of read Components for command group 4} + \text{Tsw4} \times \text{No. of write Components for command group 4} \\
 &+ \text{Tsr5} \times \text{No. of read Components for command group 5} + \text{Tsw5} \times \text{No. of write Components for command group 5}
 \end{aligned}$$

**CJ-series CPU Units**

| Command group                       | ---  | 1    |      | 2    |      | 3    |      | 4    |      | 5    |      |
|-------------------------------------|------|------|------|------|------|------|------|------|------|------|------|
| Baud rates (bps)<br>Host/components | Tps  | Tsr1 | Tsw1 | Tsr2 | Tsw2 | Tsr3 | Tsw3 | Tsr4 | Tsw4 | Tsr5 | Tsw5 |
| 9600/9600                           | 0.20 | 0.23 | 0.19 | 0.23 | 0.20 | 0.37 | 0.34 | 0.59 | 0.57 | 0.66 | 0.63 |
| 19200/19200                         | 0.13 | 0.16 | 0.13 | 0.16 | 0.13 | 0.27 | 0.25 | 0.44 | 0.42 | 0.49 | 0.46 |
| 57600/19200                         | 0.08 | 0.14 | 0.10 | 0.14 | 0.10 | 0.24 | 0.21 | 0.41 | 0.38 | 0.46 | 0.43 |

**CS-series CPU Units**

| Command group                       | ---  | 1    |      | 2    |      | 3    |      | 4    |      | 5    |      |
|-------------------------------------|------|------|------|------|------|------|------|------|------|------|------|
| Baud rates (bps)<br>Host/components | Tps  | Tsr1 | Tsw1 | Tsr2 | Tsw2 | Tsr3 | Tsw3 | Tsr4 | Tsw4 | Tsr5 | Tsw5 |
| 9600/9600                           | 0.21 | 0.22 | 0.19 | 0.22 | 0.19 | 0.35 | 0.32 | 0.54 | 0.52 | 0.62 | 0.59 |
| 19200/19200                         | 0.14 | 0.16 | 0.13 | 0.16 | 0.13 | 0.26 | 0.24 | 0.40 | 0.39 | 0.45 | 0.44 |
| 57600/19200                         | 0.10 | 0.11 | 0.10 | 0.13 | 0.10 | 0.23 | 0.20 | 0.37 | 0.35 | 0.43 | 0.41 |

**CQM1H CPU Units**

| Command group                       | ---  | 1    |      | 2    |      | 3    |      | 4    |      | 5    |      |
|-------------------------------------|------|------|------|------|------|------|------|------|------|------|------|
| Baud rates (bps)<br>Host/components | Tps  | Tsr1 | Tsw1 | Tsr2 | Tsw2 | Tsr3 | Tsw3 | Tsr4 | Tsw4 | Tsr5 | Tsw5 |
| 9600/9600                           | 0.20 | 0.22 | 0.18 | 0.23 | 0.18 | 0.38 | 0.34 | 0.60 | 0.57 | 0.69 | 0.65 |
| 19200/19200                         | 0.11 | 0.15 | 0.11 | 0.15 | 0.12 | 0.27 | 0.23 | 0.44 | 0.42 | 0.51 | 0.48 |

**CPM2A CPU Units**

| Command group                       | ---  | 1    |      | 2    |      | 3    |      | 4    |      | 5    |      |
|-------------------------------------|------|------|------|------|------|------|------|------|------|------|------|
| Baud rates (bps)<br>Host/components | Tps  | Tsr1 | Tsw1 | Tsr2 | Tsw2 | Tsr3 | Tsw3 | Tsr4 | Tsw4 | Tsr5 | Tsw5 |
| 9600/9600                           | 0.17 | 0.21 | 0.17 | 0.21 | 0.17 | 0.36 | 0.32 | 0.58 | 0.55 | 0.67 | 0.62 |
| 19200/19200                         | 0.10 | 0.14 | 0.10 | 0.14 | 0.10 | 0.26 | 0.22 | 0.43 | 0.39 | 0.49 | 0.45 |

Example: The following calculations are for a CJ-series CPU Unit with a 57,600 baud rate to the host, a 19,200 baud rate to the components, four E5CN components, and four E5GN components. Reading and writing are performed for the four E5CN components (command group 1), and only reading is performed for the four E5GN components (command group 2).

Data refresh cycle (Td)

$$= [\text{Time for command group 1}] + [\text{Time for command group 2}]$$

$$= [Tps + Tsr1 \times 4 + Tsw1 \times 4] + [Tsr2 \times 4]$$

$$= [0.08 + 0.14 \times 4 + 0.10 \times 4] + [0.14 \times 4]$$

$$= 1.60$$

$$Td = 1.6 \text{ s}$$

# Appendix B

## Example Application

This section shows the system configuration and settings of an example system to help explain how to use the Simple Communications Unit.

### System Configuration

The example system has three E5CN Temperature Controllers connected to the Simple Communications Unit.

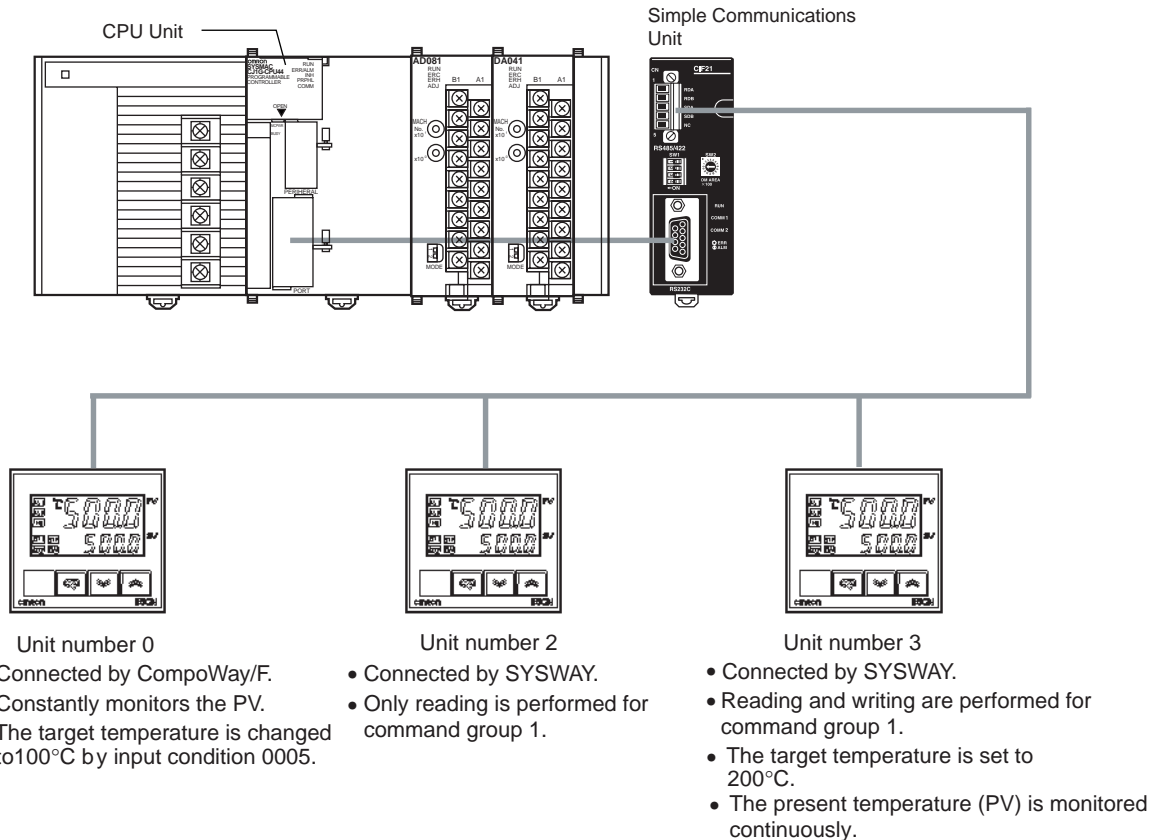

### DM Allocation

The DM allocation is shown in the following table.

| Unit settings | Area name                       | DM words         |
|---------------|---------------------------------|------------------|
| All (shared)  | Control Data Area               | D00000 to D00102 |
| Unit 0        | Unit 0 Read Variable Type Area  | D00150 to D00154 |
|               | Unit 0 Write Variable Type Area | D00160 to D00164 |
|               | Unit 0 Read Data Area           | D00170 to D00173 |
|               | Unit 0 Write Data Area          | D00180 to D00183 |
| Unit 2        | Unit 2 Read Data Area           | D00200 to D00210 |
|               | Unit 2 Write Data Area          | D00220 to D00228 |
| Unit 3        | Unit 3 Read Data Area           | D00240 to D00250 |
|               | Unit 3 Write Data Area          | D00260 to D00268 |

## Communications with CPU Unit

Baud rate: 57,600 bps

## Communications with Components

The following settings are used for the RS-485 communications:

| Item      | Setting    |
|-----------|------------|
| Baud rate | 19,200 bps |
| Data bits | 7 bits     |
| Parity    | Even       |
| Stop bits | 2 bits     |

## System Preparation

Refer to *SECTION 3 Preparation for Operation* and make the following preparations.

- 1,2,3...**
1. Connect the Simple Communications Unit.
  2. Set switches on the Unit.
  3. Make required settings in the PC.
  4. Make required settings in the components.

## Control Data Area

Items for which the DM Area addresses are shaded must be set. The other DM Area words are used to monitor status.

| Word          | Bit(s)   | Function  | Setting |
|---------------|----------|---|---------|
| <b>D00000</b> | 0 to 3   | RUN/Stop command                                    | 0 (→1)  |
|               | 4 to 7   | Communications timeout setting                      | 0       |
|               | 8 to 15  | Number of connected components                      | 03      |
| D00001        | 0 to 15  | Simple Communications Unit status                   | ---     |
| D00002        | 0 to 15  | Syntax Error DM Address                             | ---     |
| <b>D00003</b> | 0 to 7   | Read/Write Command Bits for Units 4 to 7            | 0       |
|               | 8        | Unit 3 Read Command Bit                             | 1       |
|               | 9        | Unit 3 Write Command Bit                            | 1       |
|               | 10       | Unit 2 Read Command Bit                             | 1       |
|               | 11       | Unit 2 Write Command Bit                            | 0       |
|               | 12       | Unit 1 Read Command Bit                             | 0       |
|               | 13       | Unit 1 Write Command Bit                            | 0       |
|               | 14       | Unit 0 Read Command Bit                             | 1       |
|               | 15       | Unit 0 Write Command Bit                            | 0 (→1)  |
| <b>D00004</b> | 0 to 15  | Read/Write Command Bits for Units 8 to 15           | 0000    |
| <b>D00005</b> | 0 to 15  | Read/Write Command Bits for Units 16 to 23          | 0000    |
| <b>D00006</b> | 0 to 15  | Read/Write Command Bits for Units 24 to 31          | 0000    |
| <b>D00007</b> | 0 to 7   | Unit 0 Communications protocol                      | 02      |
|               | 8 to 11  | Unit 0 Command group                                | 0       |
|               | 12 to 15 | Unit 0 Segment information                          | 0       |
| <b>D00008</b> | 0 to 15  | Starting address of Unit 0 read variable type area  | 0150    |
| <b>D00009</b> | 0 to 15  | Starting address of Unit 0 write variable type area | 0160    |

| Word                   | Bit(s)   | Function                                   | Setting |
|------------------------|----------|--|---------|
| D00010                 | 0 to 7   | Unit 1 Communications protocol             | 00      |
|                        | 8 to 11  | Unit 1 Command group                       | 0       |
|                        | 12 to 15 | Unit 1 Segment information                 | 0       |
| D00011                 | 0 to 15  | Starting address of Unit 1 read data area  | 0000    |
| D00012                 | 0 to 15  | Starting address of Unit 1 write data area | 0000    |
| D00013                 | 0 to 7   | Unit 2 Communications protocol             | 01      |
|                        | 8 to 11  | Unit 2 Command group                       | 1       |
|                        | 12 to 15 | Unit 2 Segment information                 | 1       |
| D00014                 | 0 to 15  | Starting address of Unit 2 read data area  | 0200    |
| D00015                 | 0 to 15  | Starting address of Unit 2 write data area | 0220    |
| D00016                 | 0 to 7   | Unit 3 Communications protocol             | 01      |
|                        | 8 to 11  | Unit 3 Command group                       | 1       |
|                        | 12 to 15 | Unit 3 Segment information                 | 1       |
| D00017                 | 0 to 15  | Starting address of Unit 3 read data area  | 0240    |
| D00018                 | 0 to 15  | Starting address of Unit 3 write data area | 0260    |
| D00019<br>to<br>D00102 | 0 to 15  | Not used.                                  | 0000    |

### Unit 0 Read Variable Type Area (CompoWay/F)

| Word   | Bit(s)  | Function                           | Setting |
|--------|---------|------------------------------------|---------|
| D00150 | 0 to 7  | Number of read items               | 0001    |
| D00151 | 0 to 15 | Reserved                           | ---     |
| D00152 | 0 to 15 | Starting address of read data area | 0170    |
| D00153 | 0 to 7  | Variable 1 type                    | 00C0    |
| D00154 | 0 to 15 | Variable 1 address                 | 0000    |

**Note** Variable type 00C0 and variable address 0000 indicate the PV (present temperature).

### Unit 0 Write Variable Type Area (CompoWay/F)

| Word   | Bit(s)  | Function                            | Setting |
|--------|---------|-------------------------------------|---------|
| D00160 | 0 to 7  | Number of write items               | 0001    |
| D00161 | 0 to 3  | Operation Command                   | 0000    |
| D00162 | 0 to 15 | Starting address of write data area | 0180    |
| D00163 | 0 to 7  | Variable 1 type                     | 00C1    |
| D00164 | 0 to 15 | Variable 1 address                  | 0003    |

**Note** Variable type 00C1 and variable address 0003 indicate the target temperature.

### Unit 0 Read Data Area (CompoWay/F)

| Word   | Bit(s)  | Function   |
|--------|---------|--|
| D00170 | 0 to 15 | Response monitor area<br>Contains 0000 when communications with the components are completed normally. |
| D00171 | 0 to 15 | Status<br>The component's status is read to this word.   |
| D00172 | 0 to 15 | Variable 1 read data (lower bytes) (lower 2 bytes of PV)   |
| D00173 | 0 to 15 | Variable 1 read data (upper bytes) (upper 2 bytes of PV)   |

**Note** The Temperature Controller's PV is read to D00172 and D00173 because the present temperature is registered for the read variable type area.

### Unit 0 Write Data Area (CompoWay/F)

| Word          | Bit(s)  | Function   | Setting |
|---------------|---------|--|---------|
| D00180        | 0 to 15 | Response monitor area<br>Contains 0000 when communications with the components are completed normally. | ---     |
| D00181        | 0 to 7  | Operation Command: related information* <sup>1</sup>   | ---     |
|               | 8 to 15 | Operation Command: command code* <sup>1</sup>  | ---     |
| <b>D00182</b> | 0 to 15 | Variable 1 write data (lower bytes)* <sup>2</sup>  | 0064    |
| <b>D00183</b> | 0 to 15 | Variable 1 write data (upper bytes)* <sup>2</sup>  | 0000    |

- Note 1. The operation command is set to 0000 (disabled) in the Unit 0 write variable type area, so the command code and related information are invalid.
2. Sets the hexadecimal equivalent of the target temperature (100°C) which is the variable that was registered in the Unit 0 write variable type area.

### Unit 2 Read Data Area (SYSWAY)

The segment information is 1 and the command group is 1.

| Word   | Function   |
|--------|--|
| D00200 | Response monitor area<br>Contains 0000 when communications with the components are completed normally.                                     |
| D00201 | Present temperature<br>Contains the PV in binary format. Negative values are expressed as their 2's complement.                            |
| D00202 | Status<br>Contains the status when the PV was read.  |
| D00203 | Target temperature (See note.)<br>Contains the target temperature in binary format. Negative values are expressed as their 2's complement. |
| D00204 | Alarm 1 SV (See note.)<br>Contains the alarm 1 set value in binary format. Negative values are expressed as their 2's complement.          |
| D00205 | Alarm 2 SV (See note.)<br>Contains the alarm 2 set value in binary format. Negative values are expressed as their 2's complement.          |
| D00206 | Proportional band (See note.)<br>Contains the proportional band setting in binary.   |
| D00207 | Integral time (See note.)<br>Contains the integral time setting in binary.   |
| D00208 | Derivative time (See note.)<br>Contains the derivative time setting in binary.   |

| Word   | Function   |
|--------|--|
| D00209 | Heater current monitor (See note.)<br>Contains the heater current in binary.               |
| D00210 | Heater current status (See note.)<br>Contains the status when the heater current was read. |

**Note** Only the values in D00200 to D00203 are refreshed with the data from the component because command group 1 is selected in the Communications Type for the Unit 2. Other read data, D00200 to D00210, is not refreshed. When communicating with a Temperature Controller through SYSWAY, always allocate 11 words to the read data area even if the selected command group limits the number of words actually read.

## Unit 2 Write Data Area (SYSWAY)

The segment information is 1 and the command group is 1.

Allocate words D00220 through D00228 to the Unit 2 write data area. In this example data isn't written to Unit 2, so it isn't necessary to set data in the Unit 2 write data area.

## Unit 3 Read Data Area (SYSWAY)

The segment information is 1 and the command group is 1.

| Word   | Function   |
|--------|--|
| D00240 | Response monitor area<br>Contains 0000 when communications with the components are completed normally.                                     |
| D00241 | Present temperature<br>Contains the PV in binary format. Negative values are expressed as their 2's complement.                            |
| D00242 | Status<br>Contains the status when the PV was read.  |
| D00243 | Target temperature (See note.)<br>Contains the target temperature in binary format. Negative values are expressed as their 2's complement. |
| D00244 | Alarm 1 SV (See note.)<br>Contains the alarm 1 set value in binary format. Negative values are expressed as their 2's complement.          |
| D00245 | Alarm 2 SV (See note.)<br>Contains the alarm 2 set value in binary format. Negative values are expressed as their 2's complement.          |
| D00246 | Proportional band (See note.)<br>Contains the proportional band setting in binary.   |
| D00247 | Integral time (See note.)<br>Contains the Integral time setting in binary.   |
| D00248 | Derivative time (See note.)<br>Contains the derivative time setting in binary.   |
| D00249 | Heater current monitor (See note.)<br>Contains the heater's electrical current in binary.  |
| D00250 | Heater current status (See note.)<br>Contains the status when the heater's electrical current was read.                                    |

**Note** Only the values in D00240 to D00242 are refreshed with the data from the component because command group 1 is selected in the Communications Type for the Unit 3. Other read data, D00244 to D00250, is not refreshed. When communicating with a Temperature Controller through SYSWAY, always allocate 11 words to the read data area even if the selected command group limits the number of words actually read.

### Unit 3 Write Data Area (SYSWAY)

The segment information is 1 and the command group is 1.

| Word   | Function   |
|--------|--|
| D00260 | Response monitor area<br>Contains 0000 when communications with the components are completed normally.                       |
| D00261 | Target temperature<br>00C8 (200°C)   |
| D00262 | Operation command (See note.)<br>0000  |
| D00263 | Alarm 1 SV (See note.)<br>Set the alarm 1 set value in binary format. Negative values are expressed as their 2's complement. |
| D00264 | Alarm 2 SV (See note.)<br>Set the alarm 2 set value in binary format. Negative values are expressed as their 2's complement. |
| D00265 | Proportional band (See note.)<br>Set the proportional band setting in binary.  |
| D00266 | Integral time (See note.)<br>Set the integral time setting in binary.  |
| D00267 | Derivative time (See note.)<br>Set the derivative time setting in binary.  |
| D00268 | Heater burnout detection value (See note.)<br>Set the heater burnout detection value in binary.                              |

**Note** Only the target temperature can be written to the component because command group 1 is selected in the Communication Type for Unit 3. When communicating with a Temperature Controller through SYSWAY, always allocate 9 words to the write data area even if the selected command group limits the number of words actually written.

# Ladder Program for DM Settings

The following diagram shows a sample program section used to set the required DM Area values for a CJ-series CPU Unit.

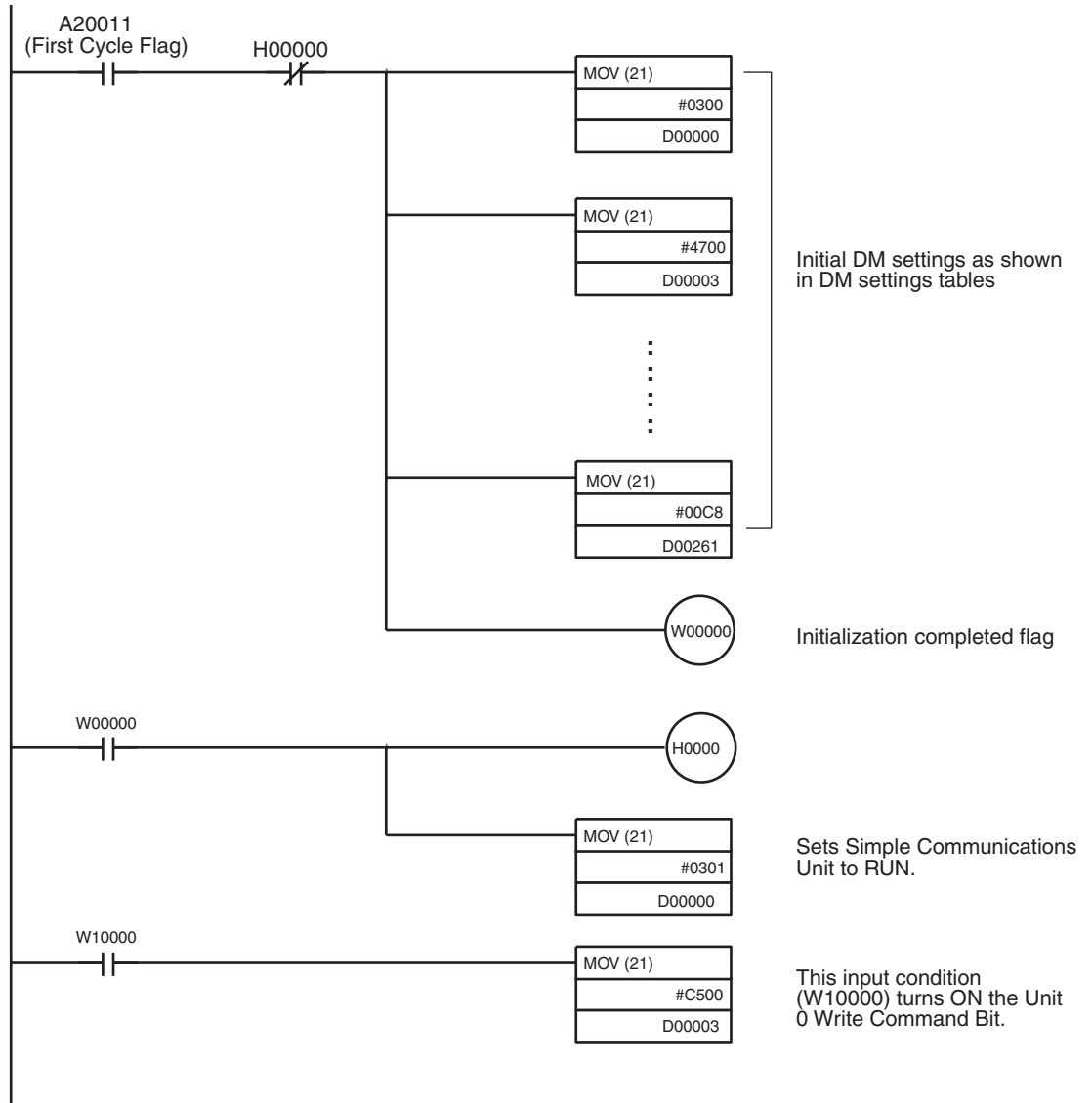



# Appendix C

## DM Area Settings Assignment Sheets

### Control Data Area

| D _____ | Contents   | Data |
|---------|--|------|
| D (+0)  | Simple Communications Unit control   |      |
| D (+1)  | Simple Communications Unit status* <sup>1</sup>  |      |
| D (+2)  | Syntax error DM address* <sup>1</sup>  |      |
| D (+3)  | Communications control for Units 0 to 7  |      |
| D (+4)  | Communications control for Units 8 to 15   |      |
| D (+5)  | Communications control for Units 16 to 23  |      |
| D (+6)  | Communications control for Units 24 to 31  |      |
| D (+7)  | Unit 0 communications type   |      |
| D (+8)  | Starting address of Unit 0 read data area (Starting address of Unit 0 read variable type area)     |      |
| D (+9)  | Starting address of Unit 0 write data area (Starting address of Unit 0 write variable type area)   |      |
| D (+10) | Unit 1 communications type   |      |
| D (+11) | Starting address of Unit 1 read data area (Starting address of Unit 1 read variable type area)     |      |
| D (+12) | Starting address of Unit 1 write data area (Starting address of Unit 1 write variable type area)   |      |
| D (+13) | Unit 2 communications type   |      |
| D (+14) | Starting address of Unit 2 read data area (Starting address of Unit 2 read variable type area)     |      |
| D (+15) | Starting address of Unit 2 write data area (Starting address of Unit 2 write variable type area)   |      |
| D (+16) | Unit 3 communications type   |      |
| D (+17) | Starting address of Unit 3 read data area (Starting address of Unit 3 read variable type area)     |      |
| D (+18) | Starting address of Unit 3 write data area (Starting address of Unit 3 write variable type area)   |      |
| D (+19) | Unit 4 communications type   |      |
| D (+20) | Starting address of Unit 4 read data area (Starting address of Unit 4 read variable type area)     |      |
| D (+21) | Starting address of Unit 4 write data area (Starting address of Unit 4 write variable type area)   |      |
| D (+22) | Unit 5 communications type   |      |
| D (+23) | Starting address of Unit 5 read data area (Starting address of Unit 5 read variable type area)     |      |
| D (+24) | Starting address of Unit 5 write data area (Starting address of Unit 5 write variable type area)   |      |
| D (+25) | Unit 6 communications type   |      |
| D (+26) | Starting address of Unit 6 read data area (Starting address of Unit 6 read variable type area)     |      |
| D (+27) | Starting address of Unit 6 write data area (Starting address of Unit 6 write variable type area)   |      |
| D (+28) | Unit 7 communications type   |      |
| D (+29) | Starting address of Unit 7 read data area (Starting address of Unit 7 read variable type area)     |      |
| D (+30) | Starting address of Unit 7 write data area (Starting address of Unit 7 write variable type area)   |      |
| D (+31) | Unit 8 communications type   |      |
| D (+32) | Starting address of Unit 8 read data area (Starting address of Unit 8 read variable type area)     |      |
| D (+33) | Starting address of Unit 8 write data area (Starting address of Unit 8 write variable type area)   |      |
| D (+34) | Unit 9 communications type   |      |
| D (+35) | Starting address of Unit 9 read data area (Starting address of Unit 9 read variable type area)     |      |
| D (+36) | Starting address of Unit 9 write data area (Starting address of Unit 9 write variable type area)   |      |
| D (+37) | Unit 10 communications type  |      |
| D (+38) | Starting address of Unit 10 read data area (Starting address of Unit 10 read variable type area)   |      |
| D (+39) | Starting address of Unit 10 write data area (Starting address of Unit 10 write variable type area) |      |
| D (+40) | Unit 11 communications type  |      |
| D (+41) | Starting address of Unit 11 read data area (Starting address of Unit 11 read variable type area)   |      |
| D (+42) | Starting address of Unit 11 write data area (Starting address of Unit 11 write variable type area) |      |
| D (+43) | Unit 12 communications type  |      |
| D (+44) | Starting address of Unit 12 read data area (Starting address of Unit 12 read variable type area)   |      |
| D (+45) | Starting address of Unit 12 write data area (Starting address of Unit 12 write variable type area) |      |
| D (+46) | Unit 13 communications type  |      |
| D (+47) | Starting address of Unit 13 read data area (Starting address of Unit 13 read variable type area)   |      |

| D _____  | Contents   | Data |
|----------|--|------|
| D (+48)  | Starting address of Unit 13 write data area (Starting address of Unit 13 write variable type area) |      |
| D (+49)  | Unit 14 communications type  |      |
| D (+50)  | Starting address of Unit 14 read data area (Starting address of Unit 14 read variable type area)   |      |
| D (+51)  | Starting address of Unit 14 write data area (Starting address of Unit 14 write variable type area) |      |
| D (+52)  | Unit 15 communications type  |      |
| D (+53)  | Starting address of Unit 15 read data area (Starting address of Unit 15 read variable type area)   |      |
| D (+54)  | Starting address of Unit 15 write data area (Starting address of Unit 15 write variable type area) |      |
| D (+55)  | Unit 16 communications type  |      |
| D (+56)  | Starting address of Unit 16 read data area (Starting address of Unit 16 read variable type area)   |      |
| D (+57)  | Starting address of Unit 16 write data area (Starting address of Unit 16 write variable type area) |      |
| D (+58)  | Unit 17 communications type  |      |
| D (+59)  | Starting address of Unit 17 read data area (Starting address of Unit 17 read variable type area)   |      |
| D (+60)  | Starting address of Unit 17 write data area (Starting address of Unit 17 write variable type area) |      |
| D (+61)  | Unit 18 communications type  |      |
| D (+62)  | Starting address of Unit 18 read data area (Starting address of Unit 18 read variable type area)   |      |
| D (+63)  | Starting address of Unit 18 write data area (Starting address of Unit 18 write variable type area) |      |
| D (+64)  | Unit 19 communications type  |      |
| D (+65)  | Starting address of Unit 19 read data area (Starting address of Unit 19 read variable type area)   |      |
| D (+66)  | Starting address of Unit 19 write data area (Starting address of Unit 19 write variable type area) |      |
| D (+67)  | Unit 20 communications type  |      |
| D (+68)  | Starting address of Unit 20 read data area (Starting address of Unit 20 read variable type area)   |      |
| D (+69)  | Starting address of Unit 20 write data area (Starting address of Unit 20 write variable type area) |      |
| D (+70)  | Unit 21 communications type  |      |
| D (+71)  | Starting address of Unit 21 read data area (Starting address of Unit 21 read variable type area)   |      |
| D (+72)  | Starting address of Unit 21 write data area (Starting address of Unit 21 write variable type area) |      |
| D (+73)  | Unit 22 communications type  |      |
| D (+74)  | Starting address of Unit 22 read data area (Starting address of Unit 22 read variable type area)   |      |
| D (+75)  | Starting address of Unit 22 write data area (Starting address of Unit 22 write variable type area) |      |
| D (+76)  | Unit 23 communications type  |      |
| D (+77)  | Starting address of Unit 23 read data area (Starting address of Unit 23 read variable type area)   |      |
| D (+78)  | Starting address of Unit 23 write data area (Starting address of Unit 23 write variable type area) |      |
| D (+79)  | Unit 24 communications type  |      |
| D (+80)  | Starting address of Unit 24 read data area (Starting address of Unit 24 read variable type area)   |      |
| D (+81)  | Starting address of Unit 24 write data area (Starting address of Unit 24 write variable type area) |      |
| D (+82)  | Unit 25 communications type  |      |
| D (+83)  | Starting address of Unit 25 read data area (Starting address of Unit 25 read variable type area)   |      |
| D (+84)  | Starting address of Unit 25 write data area (Starting address of Unit 25 write variable type area) |      |
| D (+85)  | Unit 26 communications type  |      |
| D (+86)  | Starting address of Unit 26 read data area (Starting address of Unit 26 read variable type area)   |      |
| D (+87)  | Starting address of Unit 26 write data area (Starting address of Unit 26 write variable type area) |      |
| D (+88)  | Unit 27 communications type  |      |
| D (+89)  | Starting address of Unit 27 read data area (Starting address of Unit 27 read variable type area)   |      |
| D (+90)  | Starting address of Unit 27 write data area (Starting address of Unit 27 write variable type area) |      |
| D (+91)  | Unit 28 communications type  |      |
| D (+92)  | Starting address of Unit 28 read data area (Starting address of Unit 28 read variable type area)   |      |
| D (+93)  | Starting address of Unit 28 write data area (Starting address of Unit 28 write variable type area) |      |
| D (+94)  | Unit 29 communications type  |      |
| D (+95)  | Starting address of Unit 29 read data area (Starting address of Unit 29 read variable type area)   |      |
| D (+96)  | Starting address of Unit 29 write data area (Starting address of Unit 29 write variable type area) |      |
| D (+97)  | Unit 30 communications type  |      |
| D (+98)  | Starting address of Unit 30 read data area (Starting address of Unit 30 read variable type area)   |      |
| D (+99)  | Starting address of Unit 30 write data area (Starting address of Unit 30 write variable type area) |      |
| D (+100) | Unit 31 communications type  |      |
| D (+101) | Starting address of Unit 31 read data area (Starting address of Unit 31 read variable type area)   |      |
| D (+102) | Starting address of Unit 31 write data area (Starting address of Unit 31 write variable type area) |      |

## Read Variable Type Area (CompoWay/F)

| D ____  | Contents                           | Data        | Variable name | Setting range   |
|---------|------------------------------------|-------------|---------------|---|
| D (+0)  | Number of read items               |             | ---           | 0001 to 0012 BCD  |
| D (+1)  | Reserved                           | Always 0000 | ---           | ---   |
| D (+2)  | Starting address of read data area |             | ---           | 0000 to 9999 BCD  |
| D (+3)  | Variable 1 type                    |             |               | Variable type:<br>00C0 to 00CF Hex<br>Variable address:<br>0000 to FFFF Hex |
| D (+4)  | Variable 1 address                 |             |               |   |
| D (+5)  | Variable 2 type                    |             |               |   |
| D (+6)  | Variable 2 address                 |             |               |   |
| D (+7)  | Variable 3 type                    |             |               |   |
| D (+8)  | Variable 3 address                 |             |               |   |
| D (+9)  | Variable 4 type                    |             |               |   |
| D (+10) | Variable 4 address                 |             |               |   |
| D (+11) | Variable 5 type                    |             |               |   |
| D (+12) | Variable 5 address                 |             |               |   |
| D (+13) | Variable 6 type                    |             |               |   |
| D (+14) | Variable 6 address                 |             |               |   |
| D (+15) | Variable 7 type                    |             |               |   |
| D (+16) | Variable 7 address                 |             |               |   |
| D (+17) | Variable 8 type                    |             |               |   |
| D (+18) | Variable 8 address                 |             |               |   |
| D (+19) | Variable 9 type                    |             |               |   |
| D (+20) | Variable 9 address                 |             |               |   |
| D (+21) | Variable 10 type                   |             |               |   |
| D (+22) | Variable 10 address                |             |               |   |
| D (+23) | Variable 11 type                   |             |               |   |
| D (+24) | Variable 11 address                |             |               |   |
| D (+25) | Variable 12 type                   |             |               |   |
| D (+26) | Variable 12 address                |             |               |   |

## Write Variable Type Area (CompoWay/F)

| D _____ | Contents                            | Data | Variable name | Setting range   |
|---------|-------------------------------------|------|---------------|---|
| D (+0)  | Number of write items               |      | ---           | 0000 to 0012 BCD  |
| D (+1)  | Operation Command                   |      | ---           | 0000: disable<br>0001: enable   |
| D (+2)  | Starting address of write data area |      | ---           | 0000 to 9999 BCD  |
| D (+3)  | Variable 1 type                     |      |               | Variable type:<br>00C0 to 00CF Hex<br>Variable address:<br>0000 to FFFF Hex |
| D (+4)  | Variable 1 address                  |      |               |   |
| D (+5)  | Variable 2 type                     |      |               |   |
| D (+6)  | Variable 2 address                  |      |               |   |
| D (+7)  | Variable 3 type                     |      |               |   |
| D (+8)  | Variable 3 address                  |      |               |   |
| D (+9)  | Variable 4 type                     |      |               |   |
| D (+10) | Variable 4 address                  |      |               |   |
| D (+11) | Variable 5 type                     |      |               |   |
| D (+12) | Variable 5 address                  |      |               |   |
| D (+13) | Variable 6 type                     |      |               |   |
| D (+14) | Variable 6 address                  |      |               |   |
| D (+15) | Variable 7 type                     |      |               |   |
| D (+16) | Variable 7 address                  |      |               |   |
| D (+17) | Variable 8 type                     |      |               |   |
| D (+18) | Variable 8 address                  |      |               |   |
| D (+19) | Variable 9 type                     |      |               |   |
| D (+20) | Variable 9 address                  |      |               |   |
| D (+21) | Variable 10 type                    |      |               |   |
| D (+22) | Variable 10 address                 |      |               |   |
| D (+23) | Variable 11 type                    |      |               |   |
| D (+24) | Variable 11 address                 |      |               |   |
| D (+25) | Variable 12 type                    |      |               |   |
| D (+26) | Variable 12 address                 |      |               |   |

## Read Data Area (CompoWay/F)

| D _____ | Contents                            | Data | Variable name |
|---------|-------------------------------------|------|---------------|
| D (+0)  | Response monitor area               |      | ---           |
| D (+1)  | Component status                    |      | ---           |
| D (+2)  | Variable 1 read data (lower bytes)  |      |               |
| D (+3)  | Variable 1 read data (upper bytes)  |      |               |
| D (+4)  | Variable 2 read data (lower bytes)  |      |               |
| D (+5)  | Variable 2 read data (upper bytes)  |      |               |
| D (+6)  | Variable 3 read data (lower bytes)  |      |               |
| D (+7)  | Variable 3 read data (upper bytes)  |      |               |
| D (+8)  | Variable 4 read data (lower bytes)  |      |               |
| D (+9)  | Variable 4 read data (upper bytes)  |      |               |
| D (+10) | Variable 5 read data (lower bytes)  |      |               |
| D (+11) | Variable 5 read data (upper bytes)  |      |               |
| D (+12) | Variable 6 read data (lower bytes)  |      |               |
| D (+13) | Variable 6 read data (upper bytes)  |      |               |
| D (+14) | Variable 7 read data (lower bytes)  |      |               |
| D (+15) | Variable 7 read data (upper bytes)  |      |               |
| D (+16) | Variable 8 read data (lower bytes)  |      |               |
| D (+17) | Variable 8 read data (upper bytes)  |      |               |
| D (+18) | Variable 9 read data (lower bytes)  |      |               |
| D (+19) | Variable 9 read data (upper bytes)  |      |               |
| D (+20) | Variable 10 read data (lower bytes) |      |               |
| D (+21) | Variable 10 read data (upper bytes) |      |               |
| D (+22) | Variable 11 read data (lower bytes) |      |               |
| D (+23) | Variable 11 read data (upper bytes) |      |               |
| D (+24) | Variable 12 read data (lower bytes) |      |               |
| D (+25) | Variable 12 read data (upper bytes) |      |               |

**Write Data Area (CompoWay/F)**

| D _____ | Contents                             | Data | Variable name |
|---------|--------------------------------------|------|---------------|
| D (+0)  | Response monitor area                |      | ---           |
| D (+1)  | Operation Command                    |      | ---           |
| D (+2)  | Variable 1 write data (lower bytes)  |      |               |
| D (+3)  | Variable 1 write data (upper bytes)  |      |               |
| D (+4)  | Variable 2 write data (lower bytes)  |      |               |
| D (+5)  | Variable 2 write data (upper bytes)  |      |               |
| D (+6)  | Variable 3 write data (lower bytes)  |      |               |
| D (+7)  | Variable 3 write data (upper bytes)  |      |               |
| D (+8)  | Variable 4 write data (lower bytes)  |      |               |
| D (+9)  | Variable 4 write data (upper bytes)  |      |               |
| D (+10) | Variable 5 write data (lower bytes)  |      |               |
| D (+11) | Variable 5 write data (upper bytes)  |      |               |
| D (+12) | Variable 6 write data (lower bytes)  |      |               |
| D (+13) | Variable 6 write data (upper bytes)  |      |               |
| D (+14) | Variable 7 write data (lower bytes)  |      |               |
| D (+15) | Variable 7 write data (upper bytes)  |      |               |
| D (+16) | Variable 8 write data (lower bytes)  |      |               |
| D (+17) | Variable 8 write data (upper bytes)  |      |               |
| D (+18) | Variable 9 write data (lower bytes)  |      |               |
| D (+19) | Variable 9 write data (upper bytes)  |      |               |
| D (+20) | Variable 10 write data (lower bytes) |      |               |
| D (+21) | Variable 10 write data (upper bytes) |      |               |
| D (+22) | Variable 11 write data (lower bytes) |      |               |
| D (+23) | Variable 11 write data (upper bytes) |      |               |
| D (+24) | Variable 12 write data (lower bytes) |      |               |
| D (+25) | Variable 12 write data (upper bytes) |      |               |

### Read Data Area (SYSWAY: Temperature Controllers)

| D ____  | Contents               | Data | Command group |      |      |      |      |
|---------|------------------------|------|---------------|------|------|------|------|
|         |                        |      | 1             | 2    | 3    | 4    | 5    |
| D (+0)  | Response monitor area  |      | Read          | Read | Read | Read | Read |
| D (+1)  | Present temperature    |      | Read          | Read | Read | Read | Read |
| D (+2)  | Status                 |      | Read          | Read | Read | Read | Read |
| D (+3)  | Target temperature     |      | Read          | Read | Read | Read | Read |
| D (+4)  | Alarm 1 SV             |      | ---           | ---  | Read | Read | Read |
| D (+5)  | Alarm 2 SV             |      | ---           | ---  | Read | Read | Read |
| D (+6)  | Proportional band      |      | ---           | ---  | ---  | Read | Read |
| D (+7)  | Integral time          |      | ---           | ---  | ---  | Read | Read |
| D (+8)  | Derivative time        |      | ---           | ---  | ---  | Read | Read |
| D (+9)  | Heater current monitor |      | ---           | ---  | ---  | ---  | Read |
| D (+10) | Heater current status  |      | ---           | ---  | ---  | ---  | Read |

### Read Data Area (SYSWAY: Digital Panel Meters)

| D ____  | Contents                          | Data | Command group |      |      |      |      |
|---------|-----------------------------------|------|---------------|------|------|------|------|
|         |                                   |      | 1             | 2    | 3    | 4    | 5    |
| D (+0)  | Response monitor area             |      | Read          | Read | Read | Read | Read |
| D (+1)  | Display value (Lower bytes)       |      | Read          | Read | Read | Read | Read |
| D (+2)  | Display value (Upper bytes)       |      | Read          | Read | Read | Read | Read |
| D (+3)  | Display value status              |      | Read          | Read | Read | Read | Read |
| D (+4)  | Peak hold (Lower bytes)           |      | ---           | Read | Read | ---  | Read |
| D (+5)  | Peak hold (Upper bytes)           |      | ---           | Read | Read | ---  | Read |
| D (+6)  | Peak hold status                  |      | ---           | Read | Read | ---  | Read |
| D (+7)  | Bottom hold (Lower bytes)         |      | ---           | Read | Read | ---  | Read |
| D (+8)  | Bottom hold (Upper bytes)         |      | ---           | Read | Read | ---  | Read |
| D (+9)  | Bottom hold status                |      | ---           | Read | Read | ---  | Read |
| D (+10) | Comparison value HH (Lower bytes) |      | ---           | ---  | ---  | Read | Read |
| D (+11) | Comparison value HH (Upper bytes) |      | ---           | ---  | ---  | Read | Read |
| D (+12) | Comparison value H (Lower bytes)  |      | ---           | ---  | ---  | Read | Read |
| D (+13) | Comparison value H (Upper bytes)  |      | ---           | ---  | ---  | Read | Read |
| D (+14) | Comparison value L (Lower bytes)  |      | ---           | ---  | ---  | Read | Read |
| D (+15) | Comparison value L (Upper bytes)  |      | ---           | ---  | ---  | Read | Read |
| D (+16) | Comparison value LL (Lower bytes) |      | ---           | ---  | ---  | Read | Read |
| D (+17) | Comparison value LL (Upper bytes) |      | ---           | ---  | ---  | Read | Read |

**Write Data Area (SYSWAY: Temperature Controllers)**

| D _____ | Contents                       | Data | Command group |         |         |         |         |
|---------|--------------------------------|------|---------------|---------|---------|---------|---------|
|         |                                |      | 1             | 2       | 3       | 4       | 5       |
| D (+0)  | Response monitor area          |      | Written       | Written | Written | Written | Written |
| D (+1)  | Target temperature SV          |      | Written       | Written | Written | Written | Written |
| D (+2)  | Operation Command              |      | ---           | Written | Written | Written | Written |
| D (+3)  | Alarm 1 SV                     |      | ---           | ---     | Written | Written | Written |
| D (+4)  | Alarm 2 SV                     |      | ---           | ---     | Written | Written | Written |
| D (+5)  | Proportional band              |      | ---           | ---     | ---     | Written | Written |
| D (+6)  | Integral time                  |      | ---           | ---     | ---     | Written | Written |
| D (+7)  | Derivative time                |      | ---           | ---     | ---     | Written | Written |
| D (+8)  | Heater burnout detection value |      | ---           | ---     | ---     | ---     | Written |

**Write Data Area (SYSWAY: Digital Panel Meters)**

| D _____ | Contents                          | Data | Command group |         |         |         |         |
|---------|-----------------------------------|------|---------------|---------|---------|---------|---------|
|         |                                   |      | 1             | 2       | 3       | 4       | 5       |
| D (+0)  | Response monitor area             |      | Written       | Written | Written | Written | Written |
| D (+1)  | Operation Command                 |      | ---           | ---     | Written | ---     | Written |
| D (+2)  | Comparison value HH (Lower bytes) |      | ---           | ---     | ---     | Written | Written |
| D (+3)  | Comparison value HH (Upper bytes) |      | ---           | ---     | ---     |         |         |
| D (+4)  | Comparison value H (Lower bytes)  |      | ---           | ---     | ---     | Written | Written |
| D (+5)  | Comparison value H (Upper bytes)  |      | ---           | ---     | ---     |         |         |
| D (+6)  | Comparison value L (Lower bytes)  |      | ---           | ---     | ---     | Written | Written |
| D (+7)  | Comparison value L (Upper bytes)  |      | ---           | ---     | ---     |         |         |
| D (+8)  | Comparison value LL (Lower bytes) |      | ---           | ---     | ---     | Written | Written |
| D (+9)  | Comparison value LL (Upper bytes) |      | ---           | ---     | ---     |         |         |

## Revision History

A manual revision code appears as a suffix to the catalog number on the front cover of the manual.

Cat. No. W400-E1-01

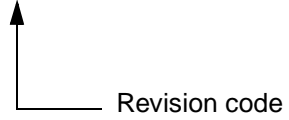

The following table outlines the changes made to the manual during each revision. Page numbers refer to the previous version.

| Revision code | Date           | Revised content     |
|---------------|----------------|---------------------|
| 01            | September 2001 | Original production |

