

YASKAWA

A1000 to GA800

PRODUCT TRANSITION GUIDE

AC DRIVE FOR INDUSTRIAL APPLICATIONS

MODEL:

CIMR-AUxxxxxxx

CAPACITIES:

208 V: 3/4 to 150 HP Heavy Duty*
3/4 to 175 HP Normal Duty
480 V: 3/4 to 900 HP Heavy Duty*
1 to 1000 HP Normal Duty
600 V: 1 to 200 HP Heavy Duty*
2 to 250 HP Normal Duty

CATALOG CODE:

GA80Uxxxxxxx

CAPACITIES:

208 V: 1/2 to 150 HP Heavy Duty*
3/4 to 150 HP Normal Duty
480 V: 3/4 to 900 HP Heavy Duty*
1 to 1000 HP Normal Duty
600 V: 3/4 to 450 HP Heavy Duty*
1 to 500 HP Normal Duty

* Note: This guide lists only comparable models. Refer to the GA800 Selection Guide No. SL.GA800.01 for a list of all available models.

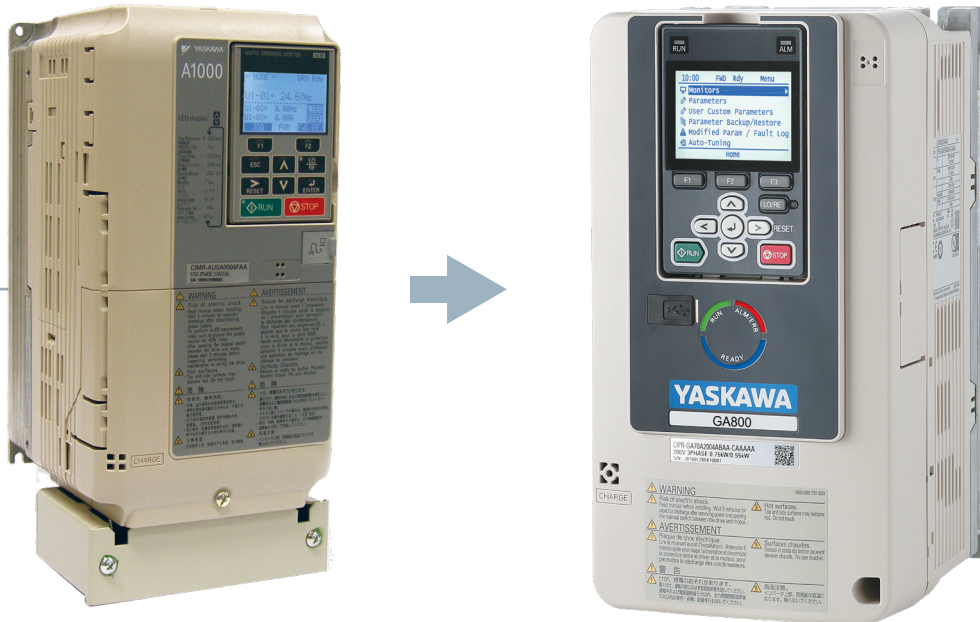

Simplify Drive Installation
Get DriveWizard® Mobile



<https://www.yaskawa.com/dwm>

Wiki
LZonline
لاہزار آن لائن
lalahzaronline.com/wiki



MENT NUMBER: PL.GA800.01

AC Drive Transition Guide

A1000 to GA800

This document is intended to help OEMs, Integrators, and End Users select and replace Yaskawa A1000 series AC drives with Yaskawa GA800 AC drives. Replacement should be conducted by qualified personnel familiar with AC drive installation. Follow local electrical codes during replacement and installation.

1	MODEL IDENTIFICATION	4
2	GA800 DRIVE SELECTION FOR A1000 REPLACEMENT	5
3	DIMENSIONS AND ADAPTERS	8
4	BRANCH CIRCUIT PROTECTION	11
5	MAIN CIRCUIT AND MOTOR WIRING	16
6	CONTROL CIRCUIT WIRING	37
7	TRANSFER OF PARAMETER SETTINGS	42
8	CARRIER FREQUENCY - C6-02 [CARRIER FREQUENCY SELECTION].	48
9	WATT LOSS COMPARISON	49
10	CONTROL I/O OPTION COMPATIBILITY	53
11	OTHER OPTION COMPATIBILITY	54

1 Model Identification

◆ Identify Your Model

The catalog numbers differ slightly between the drive series. Use this number comparison to understand nameplate location and catalog code differences between series when selecting a replacement drive.

A1000 Drive

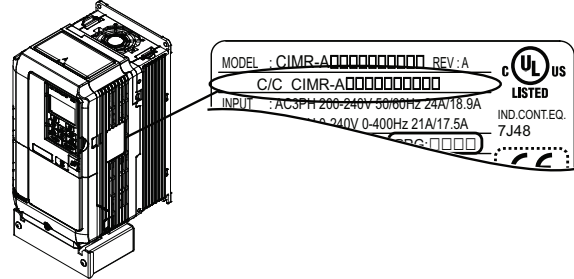

CIMR-A U 2 A 004 F A A

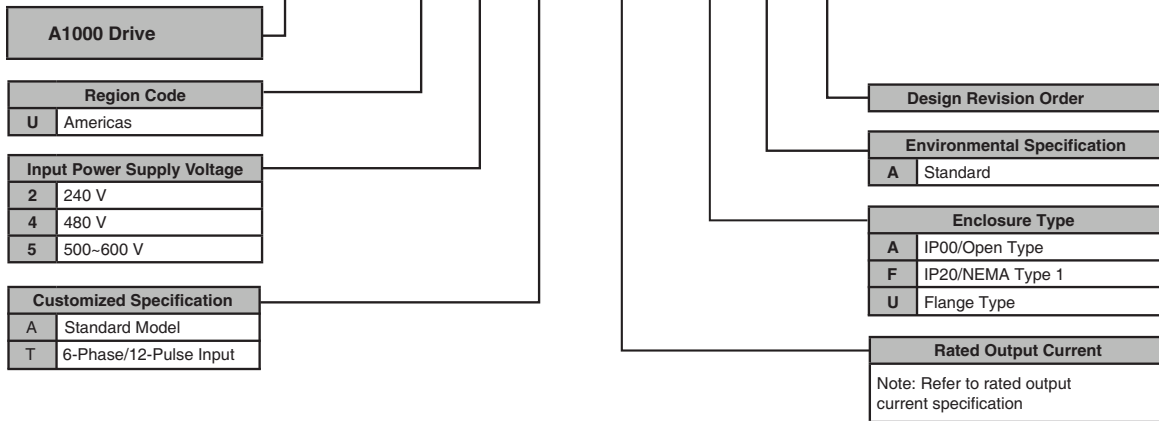

GA800 Drive

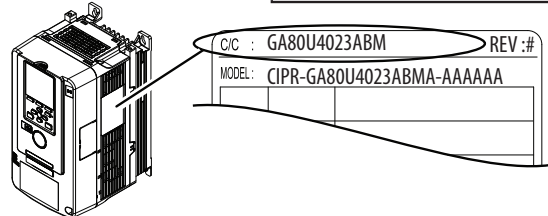

GA80 U 4 023 A B M

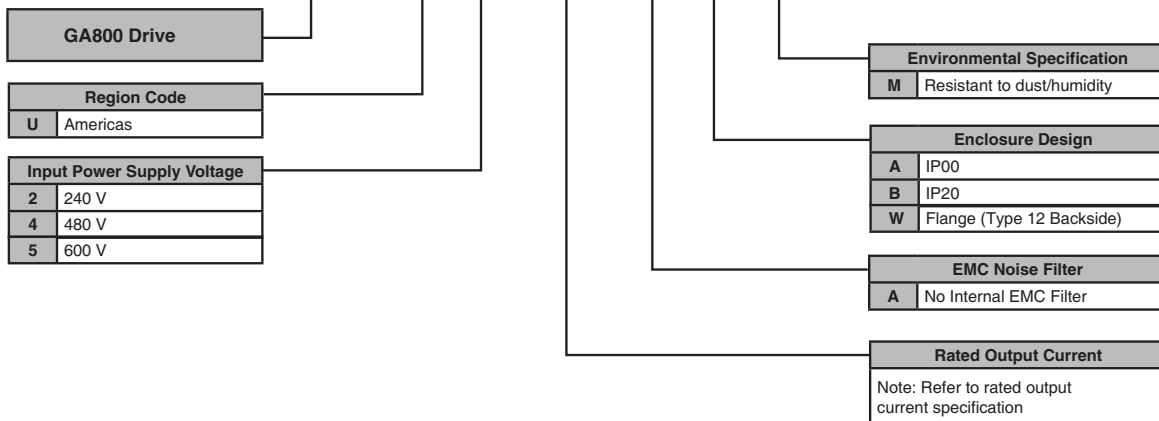

2 GA800 Drive Selection for A1000 Replacement

The following selection is recommended when replacing an A1000 with a GA800. *Table 1*, *Table 2* and *Table 3* are based on application type (Normal Duty or Heavy Duty) and driven motor size. Your motor rated power and motor rated current must not exceed the drive ratings shown in the tables below. If your requirements are greater, select a drive that meets or exceeds your power and current requirements.

Notes regarding enclosure types:

When installing a GA800 in Type 1 panels, use models ending with AM or BM.

When installing a GA800 in dust-tight or sealed panels with the heatsink external, use models ending in WM.

When installing a GA800 outside of panel, also order a Type 1 adapter kit.

Table 1 230 V Motor Applications

Normal Duty					Heavy Duty				
Rated Power (HP)	Replace this A1000		With this GA800		Rated Power (HP)	Replace this A1000		With this GA800	
	Model CIMR-AU	Rated Amps	Catalog Code GA80U	Rated Amps		Model CIMR-AU	Rated Amps	Catalog Code GA80U	Rated Amps
0.5	2A0004	3.5	2004	4.2	0.5	2A0004	3.2	2004	3.5
0.75	2A0004	3.5	2004	4.2	0.75	2A0004	3.2	2004	3.5
1	2A0006	6	2004	4.2	1	2A0006	5	2006	5
1.5	2A0008	8	2006	6	1.5	2A0008	6.9	2008	6.9
2	2A0008	8	2008	8	2	2A0010	8	2010	8
3	2A0010	9.6	2010	9.6	3	2A0012	11	2012	11
4	2A0012	12	2012	12.2	4	2A0018	14	2018	14
5	2A0018	17.5	2018	17.5	5	2A0021	17.5	2021	17.5
7.5	2A0021	21	2021	22	7.5	2A0030	25	2030	25
10	2A0030	30	2030	30	10	2A0040	33	2042	33
15	2A0040	40	2042	42	15	2A0056	47	2056	47
20	2A0056	56	2056	56	20	2A0069	60	2070	60
25	2A0069	69	2070	70	25	2A0081	75	2082	75
30	2A0081	81	2082	82	30	2A0110	85	2110	88
40	2A0110	110	2110	110	40	2A0138	115	2138	115
50	2A0138	138	2138	138	50	2A0169	145	2169	145
60	2A0169	169	2169	169	60	2A0211	180	2211	180
75	2A0211	211	2211	211	75	2A0250	215	2257	215
100	2A0250	250	2257	257	100	2A0312	283	2313	283
125	2A0312	312	2313	313	125	2A0360	346	2360	346
150	2A0360	360	2360	360	150	2A0415	415	2415	415
175	2A0415	415	Not available		175	Not available			

Table 2 460 V Motor Applications

Normal Duty					Heavy Duty				
Rated Power (HP)	Replace this A1000		With this GA800		Rated Power (HP)	Replace this A1000		With this GA800	
	Model CIMR-AU	Rated Amps	Catalog Code GA80U	Rated Amps		Model CIMR-AU	Rated Amps	Catalog Code GA80U	Rated Amps
0.5	4A0002	2.1	4002	2.1	0.5	4A0002	1.8	4002	1.8
0.75	4A0002	2.1	4002	2.1	0.75	4A0002	1.8	4002	1.8
1	4A0002	2.1	4002	2.1	1	4A0004	3.4	4004	3.4

2 GA800 Drive Selection for A1000 Replacement

Normal Duty				
Rated Power (HP)	Replace this A1000		With this GA800	
	Model CIMR-AU	Rated Amps	Catalog Code GA80U	Rated Amps
1.5	4A0004	4.1	4004	4.1
2	4A0004	4.1	4004	4.1
3	4A0005	5.4	4005	5.4
4	4A0007	6.9	4007	7.1
5	4A0009	8.8	4009	8.9
7.5	4A0011	11.1	4012	11.9
10	4A0018	17.5	4018	17.5
15	4A0023	23	4023	23.4
20	4A0031	31	4031	31
25	4A0038	38	4038	38
30	4A0044	44	4044	44
40	4A0058	58	4060	59.6
50	4A0072	72	4075	74.9
60	4A0088	88	4089	89.2
75	4A0103	103	4103	103
100	4A0139	139	4140	140
125	4A0165	165	4168	168
150	4A0208	208	4208	208
200	4A0250	250	4250	250
250	4A0296	296	4302	302
300	4A0362	362	4371	371
350	4A0414	414	4414	414
400	4A0515	515	4477	477
450	4A0515	515	4568	568
500	4A0675	675	4605	675
600	4A0930	930	4720	720
700	4A0930	930	4810	810
800	4A0930	930	4930	930
900	4A1200	930	4H11	1090
1000	4A1200	930	4H12	1200

Heavy Duty				
Rated Power (HP)	Replace this A1000		With this GA800	
	Model CIMR-AU	Rated Amps	Catalog Code GA80U	Rated Amps
1.5	4A0004	3.4	4004	3.4
2	4A0004	3.4	4005	4.8
3	4A0005	4.8	4007	5.5
4	4A0007	5.5	4009	7.2
5	4A0009	7.2	4012	9.2
7.5	4A0018	14.8	4018	14.8
10	4A0023	18	4023	18
15	4A0031	24	4031	24
20	4A0038	31	4038	31
25	4A0044	39	4044	39
30	4A0044	39	4060	45
40	4A0072	60	4075	60
50	4A0088	75	4089	75
60	4A0103	91	4103	91
75	4A0139	112	4140	112
100	4A0165	150	4168	150
125	4A0208	180	4208	180
150	4A0208	180	4250	216
200	4A0296	260	4302	260
250	4A0362	304	4371	304
300	4A0414	370	4414	371
350	4A0515	450	4477	414
400	4A0675	605	4568	477
450	4A0675	605	4605	605
500	4A0675	605	4720	605
600	4A0930	810	4810	720
700	4A0930	810	4930	810
800	4A1200	1090	4H11	930
900	4A1200	1090	4H12	1090
Not available				

Table 3 575 V Motor Applications

Normal Duty				
Rated Power (HP)	Replace this A1000		With this GA800	
	Model CIMR-AU	Rated Amps	Catalog Code GA80U	Rated Amps
1	5A0003	2.7	5002	1.7
1.5	5A0003	2.7	5003	2.7
2	5A0003	2.7	5003	2.7
3	5A0004	3.9	5004	3.9
5	5A0006	6.1	5006	6.1
7.5	5A0009	9	5009	9

Heavy Duty				
Rated Power (HP)	Replace this A1000		With this GA800	
	Model CIMR-AU	Rated Amps	Catalog Code GA80U	Rated Amps
1	5A0003	1.7	5003	2.4
1.5	5A0004	3.5	5003	2.4
2	5A0004	3.5	5004	2.7
3	5A0006	4.1	5006	3.9
5	5A0009	6.3	5009	6.1
7.5	5A0011	9.8	5011	9

2 GA800 Drive Selection for A1000 Replacement

Normal Duty				
Rated Power (HP)	Replace this A1000		With this GA800	
	Model CIMR-AU	Rated Amps	Catalog Code GA80U	Rated Amps
10	5A0011	11	5011	11
15	5A0017	17.5	5017	17
20	5A0022	22	5022	22
25	5A0027	27	5027	27
30	5A0032	32	5032	32
40	5A0041	41	5041	41
50	5A0052	52	5052	52
60	5A0062	62	5062	62
75	5A0077	77	5077	77
100	5A0099	99	5099	99
125	5A0125	125	5125	125
150	5A0145	145	5144	144
200	5A0192	192	5192	192
250	5A0242	242	5242	242

Heavy Duty				
Rated Power (HP)	Replace this A1000		With this GA800	
	Model CIMR-AU	Rated Amps	Catalog Code GA80U	Rated Amps
10	5A0017	12.5	5017	11
15	5A0022	17	5022	17
20	5A0027	22	5027	22
25	5A0032	27	5032	27
30	5A0041	32	5041	32
40	5A0052	41	5052	41
50	5A0062	52	5062	52
60	5A0077	62	5077	62
75	5A0099	77	5099	77
100	5A0125	99	5125	99
125	5A0145	130	5144	125
150	5A0192	172	5192	172
200	5A0242	200	5242	192
250	Not available			

3 Dimensions and Adapters

◆ Dimension Comparison and Mounting Adapter Kits

The standard model A1000 enclosure is wall-mount UL Type 1. GA800 dimensions in **Table 4** include the optional UL Type 1 kit assembled to the GA800. Use **Table 4** to understand physical dimensions and to select a Mounting Adapter Kit if required for replacing the A1000 with a new GA800 drive.

Note: Dimensions in this document are approximate. Refer to the Technical Manual or Dimension Diagrams for exact dimensions.

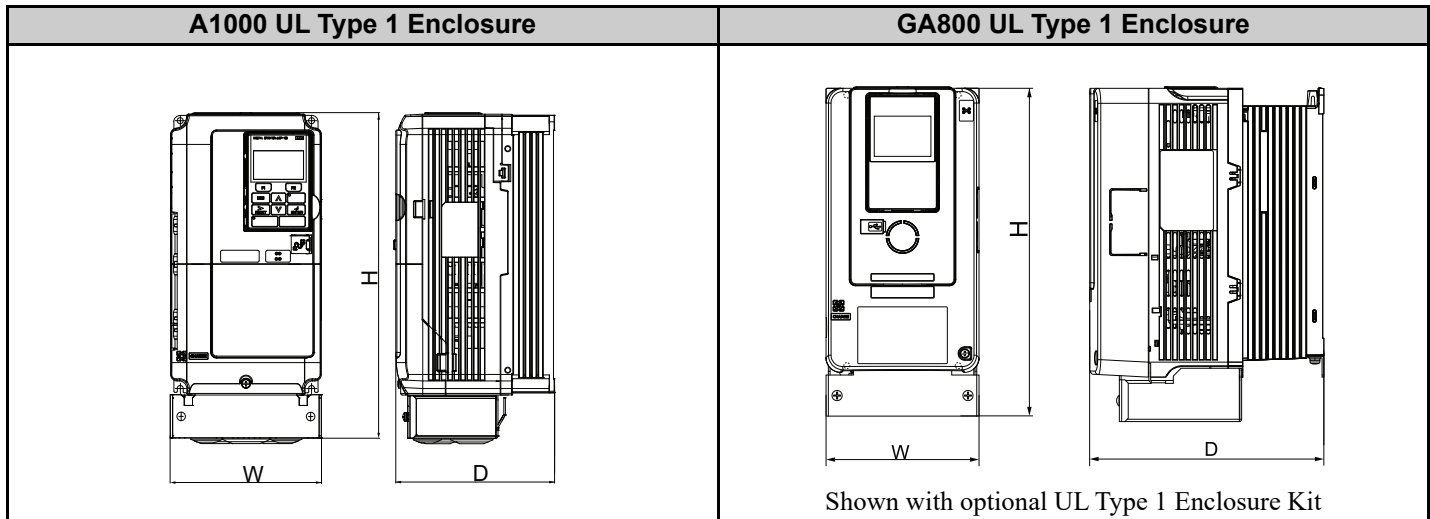

Table 4 UL Type 1 Enclosures - Dimensions and Mounting Adapter Kits

A1000 Frame	A1000 Model			GA800 Frame	GA800 Model			Mounting Adapters ^{<1>} A1000 to GA800	A1000 Exterior Dimensions for UL Type 1 Enclosures	GA800 Exterior Dimensions for UL Type 1 Enclosures
	240 V	480 V	600 V		240 V	480 V	600 V		Part Number	W x H x D in
1	0004	0002	-	1	2004	4002	-	900-195-081-001	5.51 x 12.12 x 5.9	5.51 x 11.81 x 6.93
1	0006	0004	-	1	2006	4004	-	900-195-081-001	5.51 x 12.12 x 5.9	5.51 x 11.81 x 6.93
1	0008	0005	-	1	2008	4005	-	900-195-081-001	5.51 x 12.12 x 5.9	5.51 x 11.81 x 6.93
1	0010	-	-	1	2010	-	-	900-195-081-001	5.51 x 12.12 x 5.9	5.51 x 11.81 x 6.93
1	0012	-	-	1	2012	-	-	900-195-081-001	5.51 x 12.12 x 5.9	5.51 x 11.81 x 6.93
1	-	-	0003	1.5	-	-	5003	900-195-081-001	5.51 x 12.12 x 6.68	5.51 x 11.81 x 8.31
1	-	-	0004	1.5	-	-	5004	900-195-081-001	5.51 x 12.12 x 6.68	5.51 x 11.81 x 8.31
2	0018	0007	0006	1.5	2018	4007	5006	900-195-081-001	5.51 x 12.12 x 6.57	5.51 x 11.81 x 8.31
2	0021	0009	0009	1.5	2021	4009	5009	900-195-081-001	5.51 x 12.12 x 6.57	5.51 x 11.81 x 8.31
2	-	0011	0011	1.5	2030	4012	5011	900-195-081-001	5.51 x 12.12 x 6.57	5.51 x 11.81 x 8.31
3	0030	0018	-	1.5	2042	4018	-	900-195-081-001	5.51 x 12.12 x 6.68	5.51 x 11.81 x 8.31
3	0040	0023	-	1.5	-	4023	-	900-195-081-001	5.51 x 12.12 x 6.68	5.51 x 11.81 x 8.31
4	-	0031	-	2	-	4031	-	900-195-081-002	7.09 x 13.44 x 6.68	7.09 x 13.39 x 7.95
5	0056	0038	0017	2	2056	4038	5017	900-195-081-002	7.09 x 13.44 x 7.47	7.09 x 13.39 x 7.95
5	-	-	0022	2	-	-	5022	900-195-081-002	7.09 x 13.44 x 7.47	7.09 x 13.39 x 7.95
6	0069	0044	0027	3	2070	4044	5027	-	8.66 x 15.73 x 7.87	8.66 x 15.75 x 8.94
6	0081	-	0032	3	2082	-	5032	-	8.66 x 15.73 x 7.87	8.66 x 17.13 x 8.94
7A	0110	-	-	4	2110	-	-	-	10.37 x 21.0 x 10.27	9.61 x 19.69 x 11.02
7B	-	0058	-	3.5	-	4060	-	-	10.37 x 18.28 x 10.27	8.66 x 15.75 x 9.69
8A	0138	-	-	6	2138	-	-	-	11.42 x 24.15 x 10.27	10.20 x 22.83 x 11.02

3 Dimensions and Adapters

A1000 Frame	A1000 Model			GA800 Frame	GA800 Model			Mounting Adapters <1> A1000 to GA800	A1000 Exterior Dimensions for UL Type 1 Enclosures	GA800 Exterior Dimensions for UL Type 1 Enclosures
	240 V	480 V	600 V		240 V	480 V	600 V		Part Number	W x H x D in
8B	-	0072	0041	4	-	4075	5041	-	11.35 x 20.25 x 10.27	9.61 x 19.69 x 11.02
8B	-	-	0052	4	-	-	5052	-	11.35 x 20.25 x 10.27	9.61 x 19.69 x 11.02
9	-	0088	-	6	-	4089	-	-	13.32 x 24.79 x 10.27	10.20 x 22.83 x 11.02
9	-	0103	-	6	-	4103	-	-	13.32 x 24.79 x 10.27	10.20 x 22.83 x 11.02
10	0169	0139	-	7	2169	4140	-	-	13.52 x 28.74 x 11.25	10.55 x 27.56 x 13.19
10	-	-	0062	7	-	-	5062	-	13.52 x 28.74 x 11.25	11.33 x 42.61 x 13.19
10	-	0165	-	7	-	4168	-	-	13.52 x 28.74 x 11.25	10.55 x 27.56 x 13.19
10	-	-	0077	7	-	-	5077	-	13.52 x 28.74 x 11.25	11.33 x 42.61 x 13.19
10	0211	-	-	7B	2211	-	-	-	13.52 x 28.74 x 11.25	10.55 x 30.31 x 13.19
10	-	-	0099	7B	-	-	5099	-	13.52 x 28.74 x 11.25	11.33 x 42.61 x 13.19
11	0250	0208	-	9	2257	4208	-	-	10.32 x 37.79 x 13.12	12.44 x 36.02 x 16.54
11	-	-	0125	9	-	-	5125	-	10.32 x 37.79 x 13.12	13.70 x 47.48 x 16.54
11	0312	-	-	9	2313	-	-	-	10.32 x 37.79 x 13.12	12.44 x 36.02 x 16.54
11	-	-	0145	9	-	-	5144	-	10.32 x 37.79 x 13.12	13.70 x 47.48 x 16.54
12A	-	0250	-	9	-	4250	-	-	20.29 x 45.98 x 13.89	12.44 x 36.02 x 16.54
12A	-	0296	-	9	-	4302	-	-	20.29 x 45.98 x 13.89	12.44 x 36.02 x 16.54
12A	-	-	0192	9	-	-	5192	-	20.29 x 45.98 x 13.89	13.70 x 47.48 x 16.54
12A	-	0362	0242	10	-	4371	5242	-	20.29 x 45.98 x 13.89	19.06 x 53.50 x 18.68
12A	0360	-	-	10	2360	-	-	-	20.29 x 45.98 x 13.89	19.06 x 41.14 x 18.68
-	0415	-	-	10	2415	-	-	-	-	19.06 x 41.14 x 18.68
12A	-	0362	-	10	-	4371	-	-	20.29 x 45.98 x 13.89	19.06 x 53.50 x 18.68

<1> The Mounting Adapter makes it possible to mount GA800 using the same mounting holes as A1000.

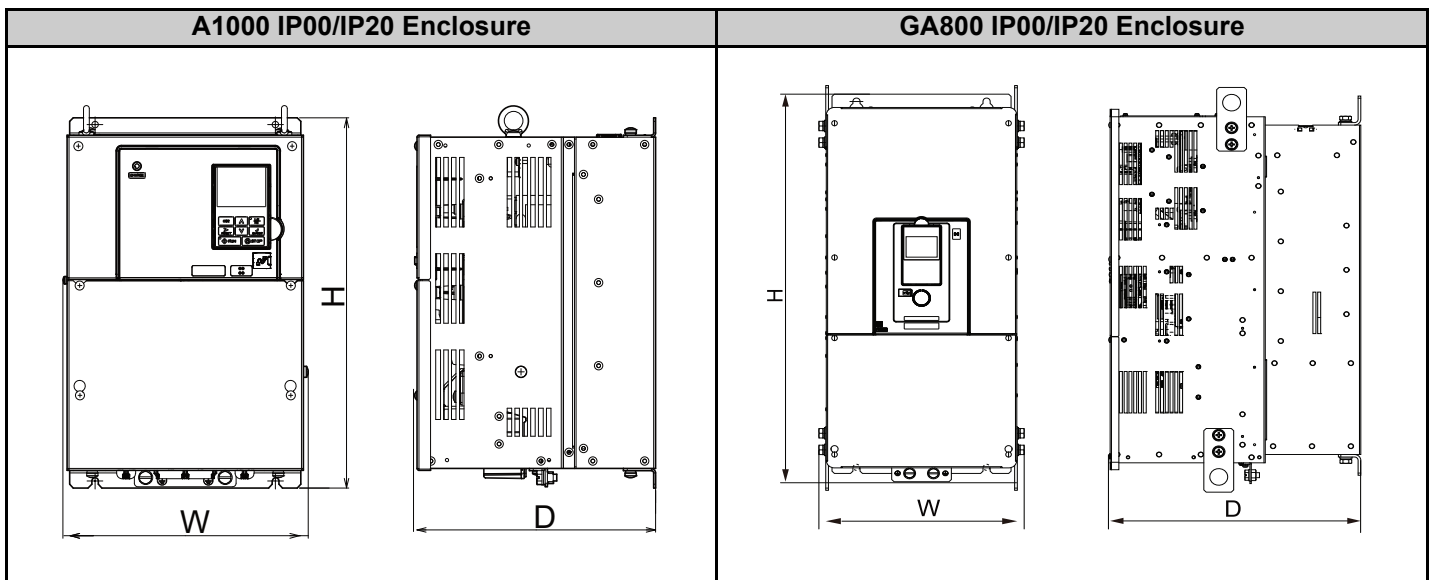

Table 5 IP00/IP20 Enclosures - Dimensions (Refer to Table 4 for Mounting Adapter Kits)

A1000 Frame	A1000 Model			GA800 Frame	GA800 Model			A1000 Exterior Dimensions for IP00/IP20 Enclosures	GA800 Exterior Dimensions for IP00/IP20 Enclosures
	240 V	480 V	600 V		240 V	480 V	600 V	W x H x D in	W x H x D in
1	0004	0002	-	1	2004	4002	-	5.51 x 10.24 x 5.79	5.51 x 10.24 x 6.93

3 Dimensions and Adapters

A1000 Frame	A1000 Model			GA800 Frame	GA800 Model			A1000 Exterior Dimensions for IP00/IP20 Enclosures	GA800 Exterior Dimensions for IP00/IP20 Enclosures
	240 V	480 V	600 V		240 V	480 V	600 V	W x H x D in	W x H x D in
1	0006	0004	-	1	2006	4004	-	5.51 x 10.24 x 5.79	5.51 x 10.24 x 6.93
1	0008	0005	-	1	2008	4005	-	5.51 x 10.24 x 5.79	5.51 x 10.24 x 6.93
1	0010	-	-	1	2010	-	-	5.51 x 10.24 x 5.79	5.51 x 10.24 x 6.93
1	0012	-	-	1	2012	-	-	5.51 x 10.24 x 5.79	5.51 x 10.24 x 6.93
1	-	-	0003	1.5	-	-	5003	5.51 x 10.24 x 6.46	5.51 x 10.24 x 8.31
1	-	-	0004	1.5	-	-	5004	5.51 x 10.24 x 6.46	5.51 x 10.24 x 8.31
2	0018	0007	0006	1.5	2018	4007	5006	5.51 x 10.24 x 6.46	5.51 x 10.24 x 8.31
2	0021	0009	0009	1.5	2021	4009	5009	5.51 x 10.24 x 6.46	5.51 x 10.24 x 8.31
2	-	0011	-	1.5	2030	4012	-	5.51 x 10.24 x 6.46	5.51 x 10.24 x 8.31
3	0030	0018	0011	1.5	2042	4018	5011	5.51 x 10.24 x 6.57	5.51 x 10.24 x 8.31
3	0040	0023	-	1.5	-	4023	-	5.51 x 10.24 x 6.57	5.51 x 10.24 x 8.31
4	-	0031	-	2	-	4031	-	7.09 x 11.81 x 6.57	7.09 x 11.81 x 7.95
5	0056	0038	0017	2	2056	4038	5017	7.09 x 11.81 x 7.36	7.09 x 11.81 x 7.95
5	-	-	0022	2	-	-	5022	7.09 x 11.81 x 7.36	7.09 x 11.81 x 7.95
6	0069	0044	0027	3	2070	4044	5027	8.66 x 13.78 x 7.76	8.66 x 13.78 x 8.94
6	0081	-	0032	3	2082	-	5032	8.66 x 13.78 x 7.76	8.66 x 13.78 x 8.94
7A	0110	-	-	4	2110	-	-	10.00 x 15.75 x 10.27	9.45 x 15.75 x 11.02
7B	-	0058	-	3.5	-	4060	-	10.00 x 15.75 x 10.27	8.66 x 13.78 x 9.69
8A	0138	-	-	6	2138	-	-	11.41 x 17.72 x 10.27	10.04 x 17.72 x 11.02
8B	-	0072	0041	4	-	4075	5041	11.41 x 17.72 x 10.27	9.45 x 15.75 x 11.02
8B	-	-	0052	4	-	-	5052	11.41 x 17.72 x 10.27	9.45 x 15.75 x 11.02
9	-	0088	-	6	-	4089	-	13.16 x 20.06 x 10.27	10.04 x 17.72 x 11.02
9	-	0103	-	6	-	4103	-	13.16 x 20.06 x 10.27	10.04 x 17.72 x 11.02
10	0169	0139	0062	7	2169	4140	5062	13.38 x 21.65 x 11.25	10.39 x 21.38 x 13.19
10	-	0165	0077	7	-	4168	5077	13.38 x 21.65 x 11.25	10.39 x 21.38 x 13.19
10	0211	-	0099	7B	2211	-	5099	13.38 x 21.65 x 11.25	10.39 x 21.38 x 13.19
11	0250	0208	0125	9	2257	4208	5125	18.32 x 27.76 x 13.12	12.28 x 27.56 x 16.54
11	0312	-	0145	9	2313	-	5144	18.32 x 27.76 x 13.12	12.28 x 27.56 x 16.54
12A	-	0250	0192	9	-	4250	5192	20.29 x 31.5 x 13.89	12.28 x 27.56 x 16.54
12A	-	0296	0242	9	-	4302	5242	20.29 x 31.5 x 13.89	12.28 x 27.56 x 16.54
12A	-	0362	-	10	-	4371	-	20.29 x 31.5 x 13.89	18.9 x 31.50 x 18.68
12A	0360	-	-	10	2360	-	-	20.29 x 31.5 x 13.89	18.9 x 31.50 x 18.68
-	0415	-	-	10	2415	-	-	20.29 x 31.5 x 13.89	18.9 x 31.50 x 18.68
12A	-	0362	-	10	-	4371	-	20.29 x 31.5 x 13.89	18.9 x 31.50 x 18.68
13	-	0414	-	10	-	4414	-	20.29 x 37.4 x 14.68	18.9 x 31.50 x 18.68
-	-	-	-	11	-	4477	-	-	21.66 x 44.70 x 19.00
14	-	0515	-	11	-	4568	-	26.86 x 44.88 x 14.72	21.66 x 44.70 x 19.00
-	-	-	-	11	-	4605	-	-	21.66 x 44.70 x 19.00
14	-	0675	-	11	-	4720	-	26.86 x 44.88 x 14.72	21.66 x 44.70 x 19.00
15	-	0930	-	12	-	4810	-	49.21 x 54.33 x 14.73	29.92 x 53.84 x 17.32
			-	12	-	4930	-		29.92 x 53.84 x 17.32
15	-	1200	-	12	-	4H11	-	49.21 x 54.33 x 14.73	29.92 x 53.84 x 17.32
			-	12	-	4H12	-		29.92 x 53.84 x 17.32

4 Branch Circuit Protection

Use this section to understand if the existing A1000 branch circuit protection is suitable to the replacement GA800 drive. Use branch circuit protection to protect against short circuits and to maintain compliance with UL 508C. Yaskawa recommends connecting semiconductor protection fuses on the input side for branch circuit protection.

◆ A1000 Branch Circuit Protection

Table 6 A1000 Normal Duty Branch Circuit Protection

Drive Model CIMR-AU	MCCB Amps <1>	Time delay Fuse Amps <2>	Non-time Delay Fuse Amps <3>	Semi-conductor Fuse Bussman PN (Fuse Ampere) <4>
240 V				
2A0004	15	6.25	10	FWH-70B (70)
2A0006	15 <1>	12	20	FWH-70B (70)
2A0008	15	15	25	FWH-70B (70)
2A0010	20	17.5	30	FWH-70B (70)
2A0012	25	20	40	FWH-70B (70)
2A0018	35	30	50	FWH-90B (90)
2A0021	45	40	70	FWH-90B (90)
2A0030	60	60	110	FWH-100B (100)
2A0040	100	90	150	FWH-200B (200)
2A0056	125	110	200	FWH-200B (200)
2A0069	150	125	225	FWH-200B (200)
2A0081	175	150	275	FWH-300A (300)
2A0110	200	175	300	FWH-300A (300)
2A0138	250	225	400	FWH-350A (350)
2A0169	300	250	450	FWH-400A (400)
2A0211	400	350	600	FWH-400A (400)
2A0250	500	450	800	FWH-600A (600)
2A0312	600	500	800	FWH-700A (700)
2A0360	700	600	1000 <5>	FWH-800A (800)
2A0415	900	800	1400 <5>	FWH-1000A (1000)
480 V				
4A0002	15	3.5	6	FWH-40B (40)
4A0004	15	7.5	12	FWH-50B (50)
4A0005	15	10	17.5	FWH-70B (70)
4A0007	15	12	20	FWH-70B (70)
4A0009	15	15	25	FWH-90B (90)
4A0011	25	20	40	FWH-90B (90)
4A0018	40	35	60	FWH-80B (80)
4A0023	45	40	70	FWH-100B (100)
4A0031	75	60	110	FWH-125B (125)
4A0038	75	75	125	FWH-200B (200)
4A0044	100	90	150	FWH-250A (250)
4A0058	100	100	150	FWH-250A (250)
4A0072	125	110	200	FWH-250A (250)
4A0088	150	150	250	FWH-250A (250)
4A0103	200	175	300	FWH-250A (250)
4A0139	250	225	400	FWH-350A (350)
4A0165	300	250	500	FWH-400A (400)
4A0208	400	350	600	FWH-500A (500)
4A0250	450	400	700	FWH-600A (600)

4 Branch Circuit Protection

Drive Model CIMR-AU	MCCB Amps <1>	Time delay Fuse Amps <2>	Non-time Delay Fuse Amps <3>	Semi-conductor Fuse Bussman PN (Fuse Ampere) <4>
4A0296	600	500	800	FWH-700A (700)
4A0362	600	600	1000 <5>	FWH-800A (800)
4A0414	800	700	1200 <5>	FWH-800A (800)
4A0515	900	800	1350 <5>	FWH-1000A (1000)
4A0675	1200	1100 <5>	1800 <5>	FWH-1200A (1200)
4A0930	Not Applicable			FWH-1200A (1200)
4A1200				FWH-1600A (1600)
600 V				
5A0003	15	6.25	10	FWP-50B (50)
5A0004	15	8	15	FWP-50B (50)
5A0006	15	12	20	FWP-60B (60)
5A0009	20	20	35	FWP-60B (60)
5A0011	30	25	45	FWP-70B (70)
5A0017	40	40	60	FWP-100B (100)
5A0022	60	50	90	FWP-100B (100)
5A0027	75	60	110	FWP-125A (125)
5A0032	75	75	125	FWP-125A (125)
5A0041	75	75	125	FWP-175A (175)
5A0052	100	90	150	FWP-175A (175)
5A0062	125	110	175	FWP-250A (250)
5A0077	150	125	225	FWP-250A (250)
5A0099	175	175	300	FWP-250A (250)
5A0125	225	225	350	FWP-350A (350)
5A0145	300	275	450	FWP-350A (350)
5A0192	400	350	600	FWP-600A (600)
5A0242	500	450	700	FWP-600A (600)

<1> Maximum MCCB Rating is 15 A, or 200% of drive input current rating, whichever is larger. MCCB voltage rating must be 600 Vac or greater.

<2> Maximum Time Delay fuse is 175% of drive input current rating. This covers any Class CC, J or T class fuse.

<3> Maximum Non-time Delay fuse is 300% of drive input current rating. This covers any CC, J or T class fuse.

<4> When using semiconductor fuses, Bussman FWH and FWP are required for UL compliance. Select FWH for 200 V Class and 400 V Class models and FWP fuses for 600 V models.

<5> Class L fuse is also approved for this rating.

Table 7 A1000 Heavy Duty Branch Circuit Protection

Drive Model CIMR-AU	MCCB Amps <1>	Time Delay Fuse Amps <2>	Non-time Delay Fuse Amps <3>	Semi-conductor Fuse Bussman PN (Fuse Ampere) <4>
240 V				
2A0004	15	5	8	FWH-70B (70)
2A0006	15	10	15	FWH-70B (70)
2A0008	15	12	17.5	FWH-70B (70)
2A0010	15	12	20	FWH-70B (70)
2A0012	20	17.5	30	FWH-70B (70)
2A0018	25	25	40	FWH-90B (90)
2A0021	35	30	50	FWH-90B (90)
2A0030	50	40	75	FWH-100B (100)
2A0040	60	60	100	FWH-200B (200)
2A0056	100	90	150	FWH-200B (200)
2A0069	125	110	200	FWH-200B (200)
2A0081	150	125	225	FWH-300A (300)
2A0110	150	125	225	FWH-300A (300)

4 Branch Circuit Protection

Drive Model CIMR-AU	MCCB Amps <1>	Time Delay Fuse Amps <2>	Non-time Delay Fuse Amps <3>	Semi-conductor Fuse Bussman PN (Fuse Ampere) <4>
2A0138	200	175	250	FWH-350A (350)
2A0169	250	225	350	FWH-400A (400)
2A0211	300	250	450	FWH-400A (400)
2A0250	400	350	600	FWH-600A (600)
2A0312	500	450	800	FWH-700A (700)
2A0360	600	500	900 <4>	FWH-800A (800)
2A0415	700	600	1100 <4>	FWH-1000A (1000)
480 V				
4A0002	15	3	5	FWH-40B (40)
4A0004	15	5	9	FWH-50B (50)
4A0005	15	7	12	FWH-70B (70)
4A0007	15	10	17.5	FWH-70B (70)
4A0009	15	12	20	FWH-90B (90)
4A0011	20	17.5	30	FWH-90B (90)
4A0018	30	25	40	FWH-80B (80)
4A0023	40	35	60	FWH-100B (100)
4A0031	50	50	80	FWH-125B (125)
4A0038	75	60	110	FWH-200B (200)
4A0044	75	75	125	FWH-250A (250)
4A0058	75	75	125	FWH-250A (250)
4A0072	100	100	150	FWH-250A (250)
4A0088	125	110	200	FWH-250A (250)
4A0103	150	150	250	FWH-250A (250)
4A0139	175	175	300	FWH-350A (350)
4A0165	225	225	400	FWH-400A (400)
4A0208	250	250	500	FWH-500A (500)
4A0250	350	350	600	FWH-600A (600)
4A0296	400	400	700	FWH-700A (700)
4A0362	500	500	800	FWH-800A (800)
4A0414	600	600	1000 <4>	FWH-800A (800)
4A0515	700	700	1200 <4>	FWH-1000A (1000)
4A0675	1000	1000 <4>	1600 <4>	FWH-1200A (1200)
4A0930	Not Applicable			FWH-1200A (1200)
4A1200				FWH-1600A (1600)
600 V				
5A0003	15	3	5	FWP-50B (50)
5A0004	15	6.25	10	FWP-50B (50)
5A0006	15	8	15	FWP-60B (60)
5A0009	15	12	20	FWP-60B (60)
5A0011	20	20	35	FWP-70B (70)
5A0017	30	25	45	FWP-100B (100)
5A0022	40	40	60	FWP-100B (100)
5A0027	60	50	90	FWP-125A (125)
5A0032	75	60	100	FWP-125A (125)
5A0041	60	50	90	FWP-175A (175)
5A0052	75	75	125	FWP-175A (175)
5A0062	100	90	150	FWP-250A (250)
5A0077	125	110	175	FWP-250A (250)
5A0099	150	125	225	FWP-250A (250)

4 Branch Circuit Protection

Drive Model CIMR-AU	MCCB Amps <1>	Time Delay Fuse Amps <2>	Non-time Delay Fuse Amps <3>	Semi-conductor Fuse Bussman PN (Fuse Ampere) <4>
5A0125	175	175	300	FWP-350A (350)
5A0145	250	225	350	FWP-350A (350)
5A0192	300	250	400	FWP-600A (600)
5A0242	400	350	600	FWP-600A (600)

<1> Maximum MCCB Rating is 15 A, or 200% of drive input current rating, whichever is larger. MCCB voltage rating must be 600 VAC or greater.

<2> Maximum Time Delay fuse is 175% of drive input current rating. This covers any Class CC, J or T class fuse.

<3> Maximum Non-time Delay fuse is 300% of drive input current rating. This covers any CC, J or T class fuse.

<4> When using semiconductor fuses, Bussman FWH and FWP are required for UL compliance. Select FWH for 200 V Class and 400 V Class models and FWP fuses for 600 V models.

◆ GA800 Branch Circuit Protection

Drive Catalog Code GA80U	Alternate Time-Delay Fuse Class CC, J, or T <1> Maximum Amp Rating (Maximum SCCR (kA))	Semiconductor Fuse Manufacturer: EATON/Bussmann
240 V		
2006	10 (65)	FWH-45B
2008	12 (65)	FWH-45B
2010	15 (65)	FWH-45B
2012	20 (65)	FWH-50B, FWH-80B
2018	30 (65)	FWH-80B, FWH-100B
2021	35 (65)	FWH-80B, FWH-100B
2030	50 (100)	FWH-100B, FWH-125B
2042	70 (100)	FWH-150B
2056	90 (100)	FWH-200B
2070	110 (100)	FWH-200B, FWH-225A
2082	125 (100)	FWH-225A, FWH-250A
2110	175 (100)	FWH-225A, FWH-250A
2138	225 (100)	FWH-275A, FWH-300A
2169	250 (100)	FWH-275A, FWH-350A
2211	350 (100)	FWH-325A, FWH-450A
2257	400 (100)	FWH-600A
2313	500 (100)	FWH-700A, FWH-800A
2360	600 (100) <2>	FWH-800A, FWH-1000B
2415	800 (100) <2>	FWH-1000B
480 V		
4002	3.5 (100)	FWH-40B, FWH-50B
4004	7 (100)	FWH-50B
4005	9 (100)	FWH-50B
4007	12 (100)	FWH-60B
4009	15 (100)	FWH-60B
4012	20 (100)	FWH-60B
4018	30 (100)	FWH-80B
4023	40 (100)	FWH-90B
4031	50 (100)	FWH-125B, FWH-150B
4038	60 (100)	FWH-200B
4044	70 (100)	FWH-200B
4060	100 (100)	FWH-225A
4075	125 (100)	FWH-250A
4089	150 (100)	FWH-250A, FWH-275A
4103	175 (100)	FWH-250A, FWH-275A

4 Branch Circuit Protection

Drive Catalog Code GA80U	Alternate Time-Delay Fuse Class CC, J, or T <1> Maximum Amp Rating (Maximum SCCR (kA))	Semiconductor Fuse Manufacturer: EATON/Bussmann	
4140	225 (100)	FWH-300A	
4168	250 (100)	FWH-325A, FWH-400A	
4208	350 (100)	FWH-500A	
4250	400 (100)	FWH-600A	
4302	500 (100)	FWH-700A	
4371	Not applicable	FWH-800A	
4414		FWH-800A, FWH-1000B	
4477		FWH-1000B, FWH-1200B	
4568		FWH-1000B, FWH-1200B	
4605		FWH-1200B, FWH-1400A	
4720		FWH-1200B, FWH-1400A	
4810		FWH-1200B	
4930		FWH-1200B	
4H11		FWH-1600A	
4H12		FWH-1600A	
600 V			
5002		2.5 (100)	FWP-70B
5003		4.5 (100)	FWP-70B
5004		6 (100)	FWP-70B
5006	10 (100)	FWP-70B	
5009	15 (100)	FWP-70B	
5011	17.5 (100)	FWP-70B	
5017	25 (100)	FWP-100B	
5022	35 (100)	FWP-100B	
5027	45 (100)	FWP-125A	
5032	50 (100)	FWP-125A	
5041	70 (100)	FWP-150A	
5052	90 (100)	FWP-150A	
5062	Not applicable	FWP-150A	
5077		FWP-150A	
5099		FWP-150A	
5125		A070UD31LI250 <3>	
5144		A070UD31LI250 <3>	
5192		A070UD32LI315 <3>	
5242		A070UD32LI350 <3>	

<1> Class T fuses are fast-acting (non-time delay only).
 <2> For fuses rated 601 - 800 amps, Class T fuses must be used.
 <3> Manufacturer: Mersen

5 Main Circuit and Motor Wiring

Use this section to convert the A1000 main circuit wiring for installation to the GA800.

Key wiring differences between the A1000 and GA800 are:

- A1000 uses crimp terminals/ring lugs and GA800 uses bare wire on many models. (except for ground terminal)
- Terminal sizes, shapes or physical location may differ slightly between A1000 and GA800.

Information in this section:

- **Main Circuit Connection Diagram on page 16**
- **Main Circuit Wiring Procedure on page 16**
- **Wire Termination Comparison on page 17**
- **Main Circuit and Motor Terminal Layout Comparison on page 18**
- **Main Circuit and Motor Wire Gauge and Tightening Torque on page 23**

◆ Main Circuit Connection Diagram

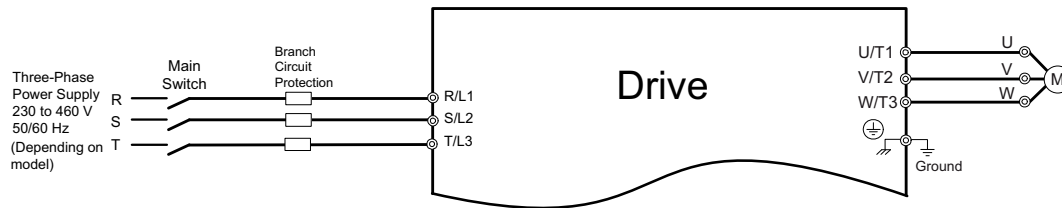

Figure 1 Main Circuit Connection Diagram (Typical)

◆ Main Circuit Wiring Procedure

Follow the GA800 Installation & Primary Operation Manual (No. TOEPC71061737) for all wiring procedures.

NOTICE:

- A screwdriver or hexagonal tool must be used when wiring the terminal.
- When stranded wire is used, wire it so that no loose wire strands protrude out of the connection. Do not excessively twist stranded wire.
- Do not solder wire ends.
- Do not use bent or crushed wire. Cut off any rough ends of the wire before installation.

1. Label the A1000 terminal wires before removing.
2. Remove crimp terminals if needed, and prepare wire ends. *Refer to Main Circuit Termination Comparison on page 17.*
3. Expose the required length of bare wire by stripping the insulation to the strip length in *Table 10* or *Table 11*.
4. Wire the terminals. The wire will correctly fit the terminal block when the insulation is stripped to expose the correct wire length.
5. Tighten screws according to the tightening torque listed in *Table 9*.
6. Dress and arrange wires so that excessive wire tension is not applied to the terminal block.
7. After connecting the wires, gently pull on the wires to check that they do not pull out.
8. Regularly tighten any loose terminal block screws to their specified tightening torque.

◆ Wire Termination Comparison

This section summarizes the differences in wire termination between A1000 and GA800. Generally the crimp terminal ends/ring lugs present on the A1000 must be removed and the wire stripped to bare wire for installation to the GA800. Refer to the GA800 Installation & Primary Operation Manual No. TOEPC71061737 for more information on wire termination.

Table 8 Main Circuit Termination Comparison

240 V Model Main Circuit Wire Termination				480 V Model Main Circuit Wire Termination				600 V Model Main Circuit Wire Termination									
A1000	Type	GA800	Type	A1000	Type	GA800	Type	A1000	Type	GA800	Type						
0004	Bare Wire or Ring Lug	2004	Bare Wire	0002	Bare Wire or Ring Lug	4002	Bare Wire	0003	Bare Wire or Ring Lug	5003	Bare Wire						
0006		2006		4004		5004											
0008		2008		4005		5006											
0010		2010		4007		5009											
0012		2012		4009		5011											
0018		2018		4012		5017											
0021		2021		4018		5022											
0030		2030		4023		5027											
0040		2042		4031		5032											
0056		2056		4038		5041											
0069		2070		4044		5052											
0081		2082		4060		5062											
0110		Ring Lug		2110		S2/0-38R-X		0058		Ring Lug		4075	S1/0-38R-X	0077	Ring Lug	5077	S2/0-12R
0138				2138				0072				4089		0099		5099	
0269	2169		0103	4103	0125		5125										
0211	2211		0139	4140	0145		5144										
0250	2257		0165	4168	0192		5192										
0312	2313		0208	4208	0242		5242										
0360	2360		0250	4250	Ring Lugs are Panduit part numbers. Refer to the drive product instructions for details on factory recommended lugs.												
0415	2415		0296	4302													
Ring Lugs are Panduit part numbers. Refer to the drive product instructions for details on factory recommended lugs.				0362	Ring Lug		4371	S250-12R-5									
							0414	4414	LCA300-12-X & LCAX300-12-6								
				0414		4477	S250-12R-5 & S4/0-12R-5										
				0515		4568	S250-12R-5 & S4/0-12R-5										
				0675		4605	LCA300-12-X LCAX300-12-6										
				0930		4810	LCA3/0-12-X										
						4930	LCA4/0-12-X										
				1200		4H11	LCA250-12-X										
						4H12	LCA300-12-X										

5 Main Circuit and Motor Wiring

◆ Main Circuit and Motor Terminal Layout Comparison

Terminal location and appearance differs slightly between A1000 and GA800. Use this section to understand differences to prepare for wiring the GA800.

Table 9 Main Circuit and Motor Circuit Terminal Layout

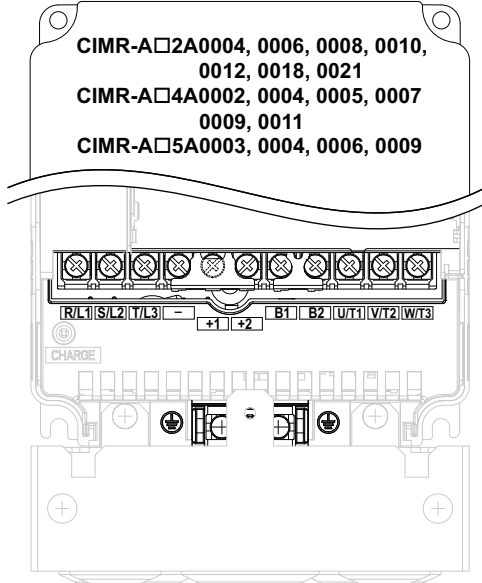
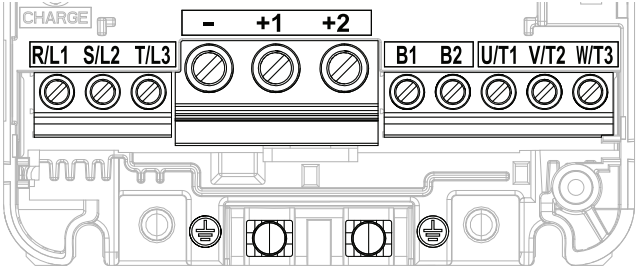
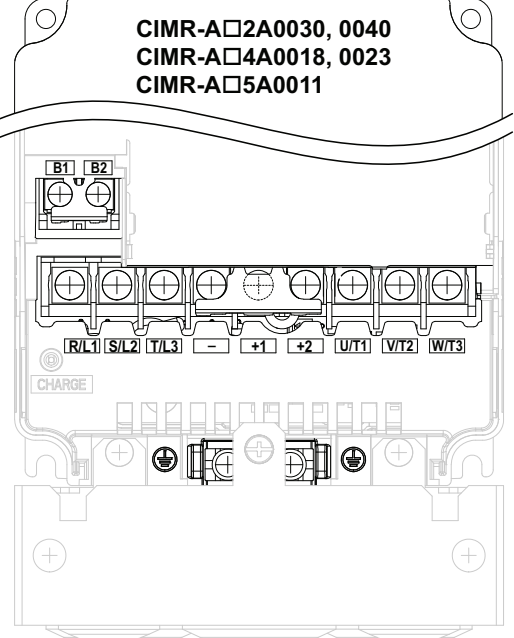
A1000 Main Circuit Terminal Configuration	GA800 Main Circuit Terminal Configuration
<p data-bbox="263 436 617 562"> CIMR-A□2A0004, 0006, 0008, 0010, 0012, 0018, 0021 CIMR-A□4A0002, 0004, 0005, 0007 0009, 0011 CIMR-A□5A0003, 0004, 0006, 0009 </p> 	<p data-bbox="1003 844 1234 932"> GA80U2004 - 2042 GA80U4002 - 4023 GA80U5002 - 5011 </p> 
<p data-bbox="305 1050 565 1129"> CIMR-A□2A0030, 0040 CIMR-A□4A0018, 0023 CIMR-A□5A0011 </p> 	

A1000 Main Circuit Terminal Configuration

**CIMR-A□2A0056
 CIMR-A□4A0031, 0038, 0044
 CIMR-A□5A0017, 0022, 0027, 0032**

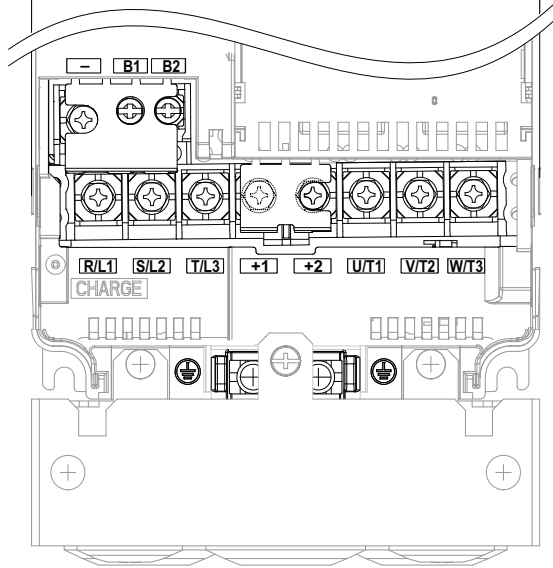

GA800 Main Circuit Terminal Configuration

**GA80U2056
 GA80U4031, 4038
 GA80U5017, 5022**

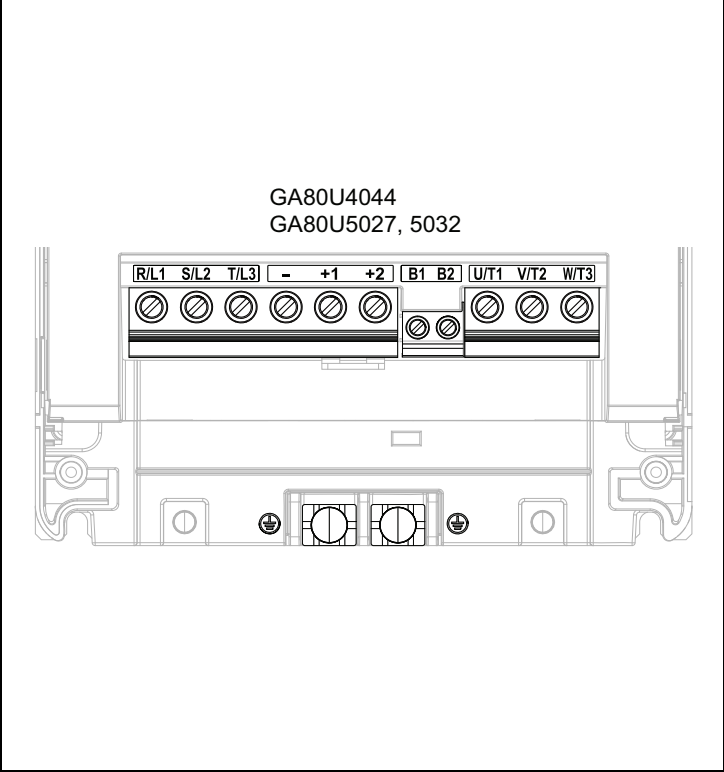
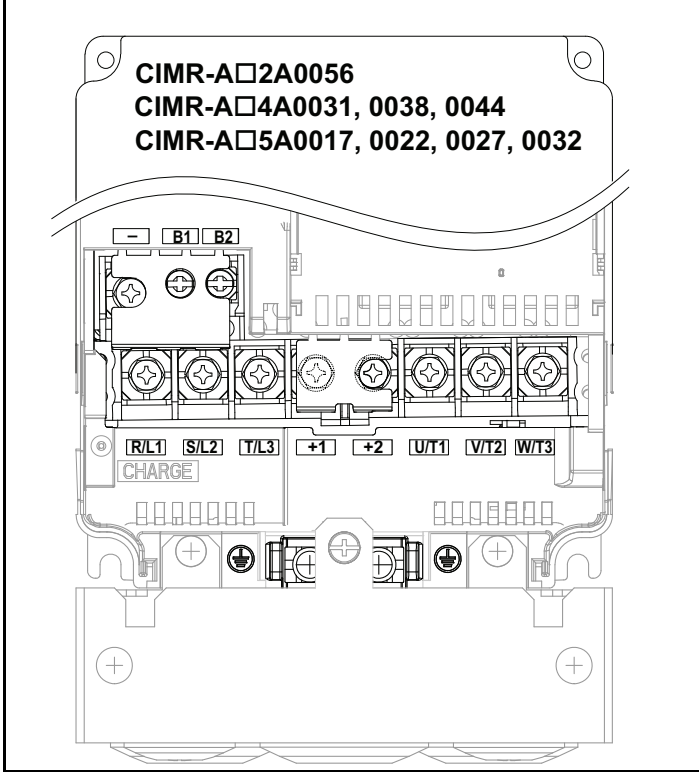
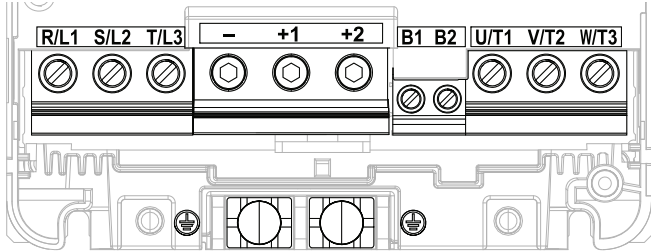

5 Main Circuit and Motor Wiring

A1000 Main Circuit Terminal Configuration

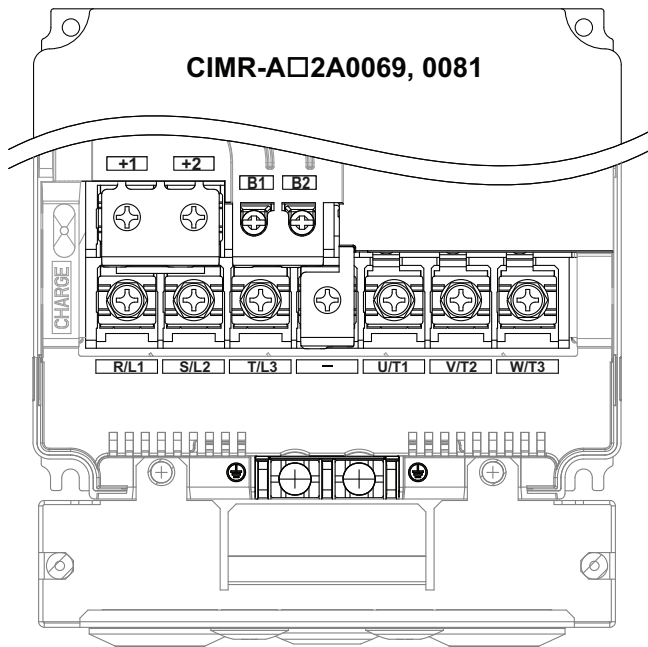

GA800 Main Circuit Terminal Configuration

GA80U2070, 2082

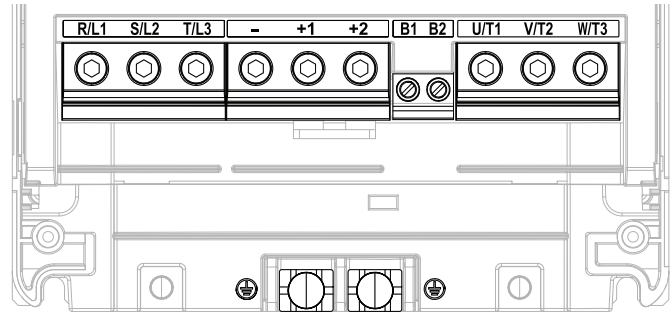

GA80U2110

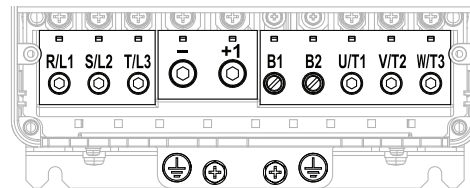

GA80U2138

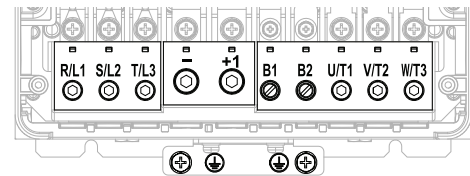

GA80U4060

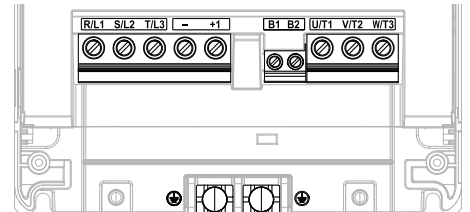

GA80U4075

GA80U5041, 5052

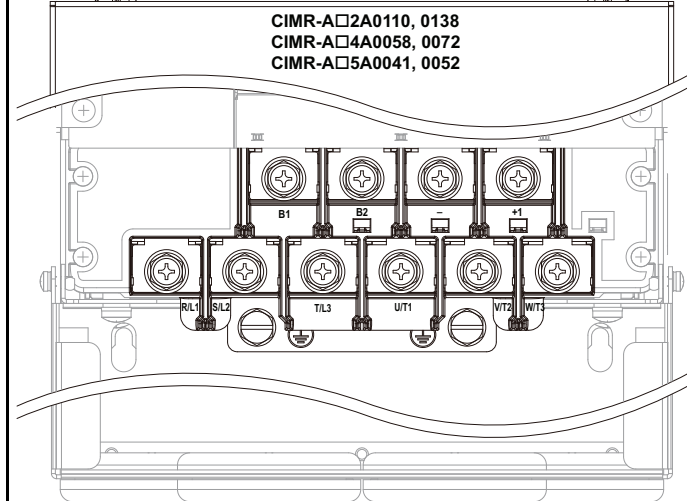
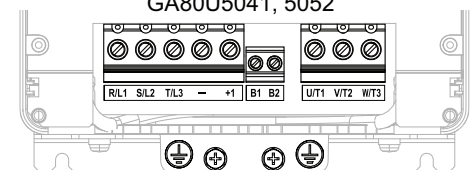

A1000 Main Circuit Terminal Configuration

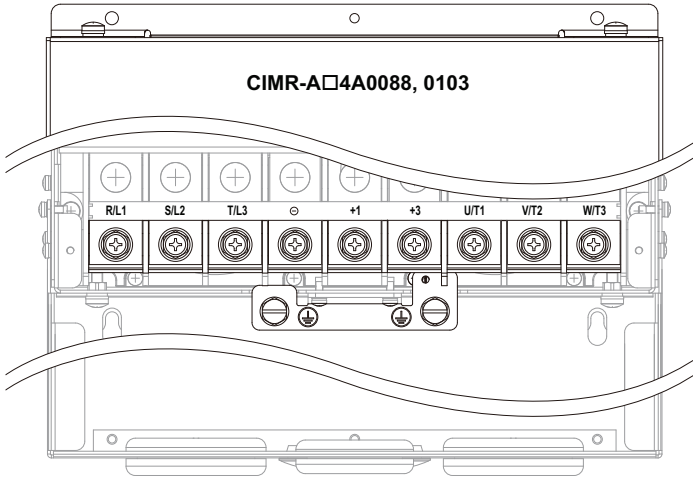

GA800 Main Circuit Terminal Configuration

GA80U4089

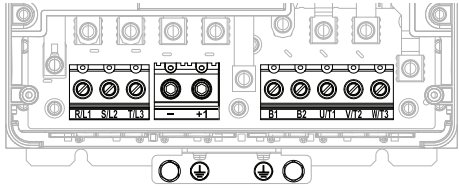

GA80U4103

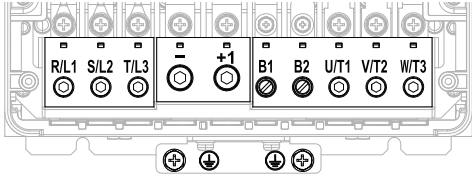

GA80U2169, 2211
GA80U4140, 4168
GA80U5062 - 5099

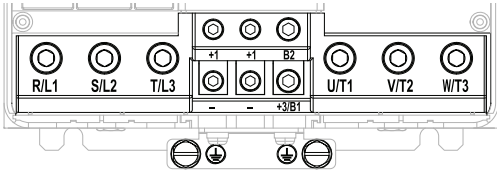

GA80U2257, 2313
GA80U4208 - 4302
GA80U5125, 5144

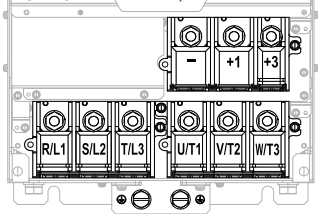

GA80U2360, 2415
GA80U4371, 4414
GA80U5192, 5242

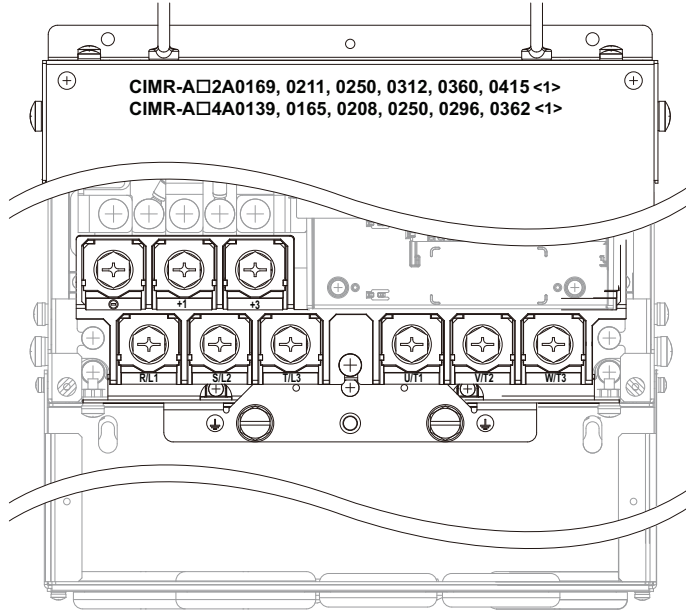
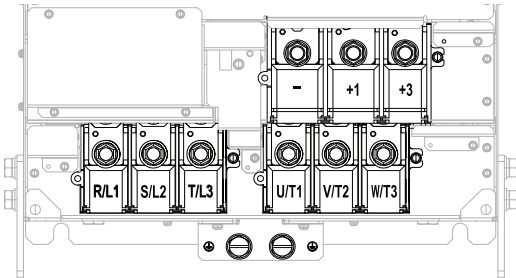

5 Main Circuit and Motor Wiring

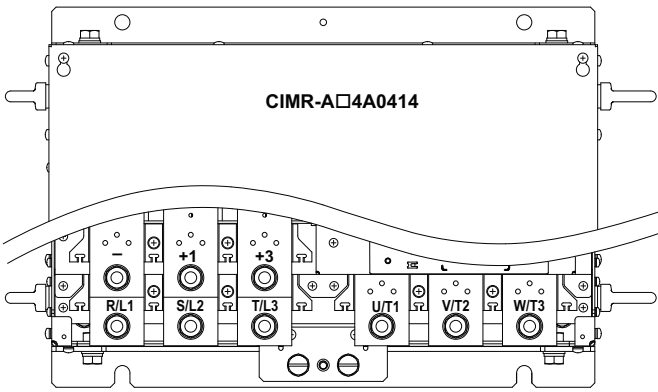
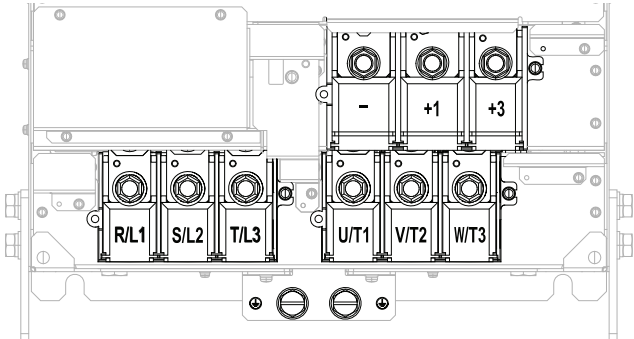
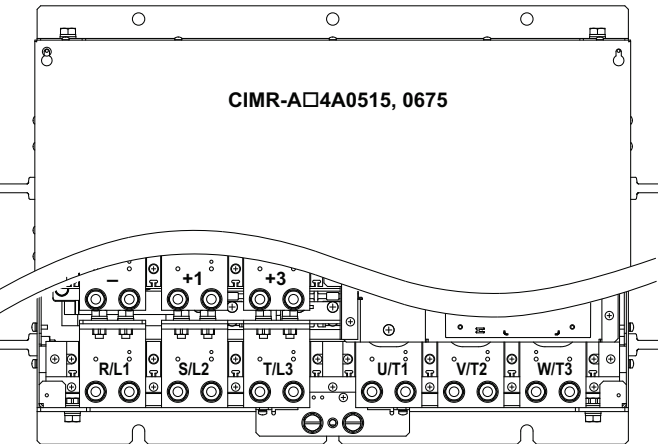
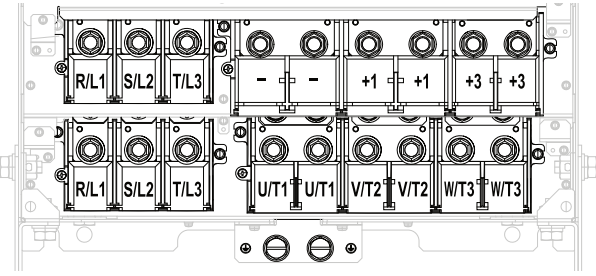
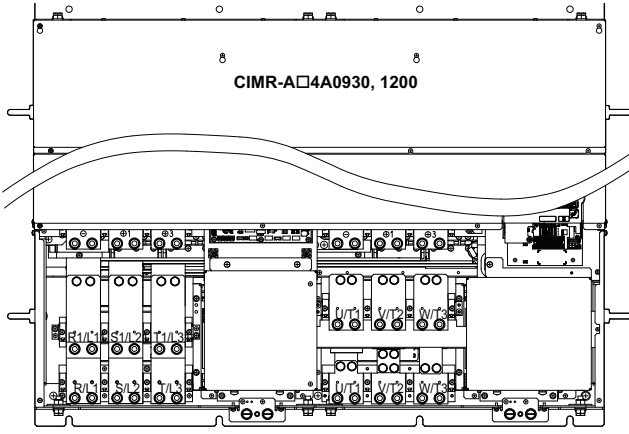
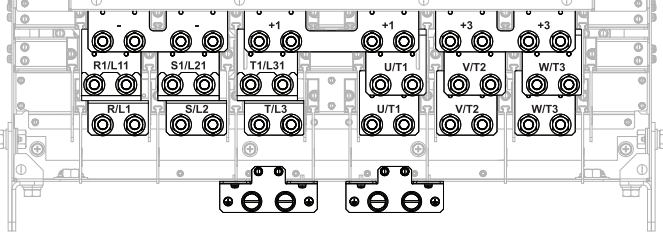
A1000 Main Circuit Terminal Configuration	GA800 Main Circuit Terminal Configuration
<p data-bbox="354 331 511 357">CIMR-A□4A0414</p> 	<p data-bbox="930 226 1328 258">GA80U2360, 2415, 4371, 4414</p> 
<p data-bbox="321 783 540 808">CIMR-A□4A0515, 0675</p> 	<p data-bbox="1027 762 1247 787">GA80U4470-4720</p> 
<p data-bbox="337 1266 524 1291">CIMR-A□4A0930, 1200</p> 	<p data-bbox="1044 1287 1222 1312">GA80U4810 - 4H12</p> 

◆ Main Circuit and Motor Wire Gauge and Tightening Torque

Table 10 and **Table 11** list Applicable Gauge wires accepted by the drive main circuit terminals. Verify the existing A1000 wire size is within the range of the Applicable Gauge for the GA800.

Table 10 240 V Main Circuit and Motor Wire Gauge and Tightening Torque

Model	A1000 Model CIMR-AU	Terminal Symbol	Applicable Gauge (IP20 Applicable Gauge <I>) AWG, kcmil	Wire Strip Length mm	Tightening Torque N-m (lb-in)	
	GA800 Catalog Code GA80U					
A1000	2A0004 2A0006 2A0008 2A0010 2A0012	R/L1, S/L2, T/L3	14 - 10	-	-	
		U/T1, V/T2, W/T3				
		-, +1, +2				
		B1, B2				
		⊥				
	2A0018	R/L1,S/L2,T/L3	12 - 10	-	-	
		U/T1, V/T2, W/T3	14 - 10			
		-, +1, +2				
B1, B2						
GA800	2004 2006 2008 2010 2012 2018	R/L1,S/L2,T/L3		14 - 6 (14 - 6)	10	1.5 - 1.7 (13.5 - 15)
		U/T1, V/T2, W/T3	14 - 6 (14 - 6)	10		
		-, +1, +2	14 - 3 (14 - 3)	18	2.3 - 2.5 (19.8 - 22)	
		B1, B2	14 - 10 (14 - 10)	10	1.5 - 1.7 (13.5 - 15)	
		⊥	14 - 8 (-)	-	1.2 - 1.5 (10.6 - 13.3)	
		A1000	2A0021	R/L1,S/L2,T/L3	12 - 10	-
U/T1, V/T2, W/T3						
-, +1, +2						
B1, B2						
⊥						
GA800	2021	R/L1,S/L2,T/L3	14 - 6 (14 - 6)	10	1.5 - 1.7 (13.5 - 15)	
		U/T1, V/T2, W/T3		10		
		-, +1, +2		14 - 3 (14 - 3)	18	2.3 - 2.5 (19.8 - 22)
		B1, B2		14 - 10 (14 - 10)	10	1.5 - 1.7 (13.5 - 15)
		⊥		12 - 8 (-)	-	1.2 - 1.5 (10.6 - 13.3)
A1000	2A0030	R/L1,S/L2,T/L3	10 - 6	-	-	
		U/T1, V/T2, W/T3				
		-, +1, +2				
		B1, B2				
		⊥				
GA800	2030	R/L1,S/L2,T/L3	14 - 6 (14 - 6)	10	1.5 - 1.7 (13.5 - 15)	
		U/T1, V/T2, W/T3		10		
		-, +1, +2		14 - 3 (14 - 3)	18	2.3 - 2.5 (19.8 - 22)
		B1, B2		14 - 10 (14 - 10)	10	1.5 - 1.7 (13.5 - 15)
		⊥		10 - 8 (-)	-	2.0 - 2.5 (17.7 - 22.1)

5 Main Circuit and Motor Wiring

Model	A1000 Model CIMR-AU	Terminal Symbol	Applicable Gauge (IP20 Applicable Gauge <I>) AWG, kcmil	Wire Strip Length mm	Tightening Torque N-m (lb-in)
	GA800 Catalog Code GA80U				
A1000	2A0040	R/L1,S/L2,T/L3	8 - 6	-	-
		U/T1, V/T2, W/T3			
		-, +1, +2	6		
		B1, B2	12 - 10		
		⊕	10 - 8		
GA800	2042	R/L1,S/L2,T/L3	14 - 6 (14 - 6)	10	1.5 - 1.7 (13.5 - 15)
		U/T1, V/T2, W/T3		10	
		-, +1, +2	14 - 3 (14 - 3)	18	2.3 - 2.5 (19.8 - 22)
		B1, B2	14 - 10 (14 - 10)	10	1.5 - 1.7 (13.5 - 15)
		⊕	10 - 8 (-)	-	2.0 - 2.5 (17.7 - 22.1)
A1000	2A0056	R/L1,S/L2,T/L3	6 - 4	-	-
		U/T1, V/T2, W/T3			
		-, +1, +2	10 - 6		
		B1, B2			
		⊕	8 - 6		
GA800	2056	R/L1,S/L2,T/L3	14 - 3 (8 - 3)	18	2.3 - 2.5 (19.8 - 22)
		U/T1, V/T2, W/T3	14 - 4 (10 - 4)	18	
		-, +1, +2	14 - 1 (8 - 1)	20	5 - 5.5 (45 - 49)
		B1, B2	14 - 8 (14 - 8)	10	1.5 - 1.7 (13.5 - 15)
		⊕	8 - 6 (-)	-	5.4 - 6.0 (47.8 - 53.1)
A1000	2A0069	R/L1,S/L2,T/L3	4 - 3	-	-
		U/T1, V/T2, W/T3			
		-, +1, +2	8 - 6		
		B1, B2			
		⊕	6 - 4		
GA800	2070	R/L1, S/L2, T/L3	14 - 1 (6 - 1)	20	5 - 5.5 (45 - 49)
		U/T1, V/T2, W/T3	14 - 3 (6 - 3)	20	
		-, +1, +2	14 - 1/0 (4 - 1/0)	20	1.5 - 1.7 (13.5 - 15)
		B1, B2	14 - 8 (14 - 8)	10	
		⊕	6 - 4 (-)	-	5.4 - 6.0 (47.8 - 53.1)
A1000	2A0081	R/L1, S/L2, T/L3	3 - 2	-	-
		U/T1, V/T2, W/T3			
		-, +1, +2	6		
		B1, B2			
		⊕	6 - 4		
GA800	2082	R/L1, S/L2, T/L3	14 - 1/0 (6 - 1/0)	20	5 - 5.5 (45 - 49)
		U/T1, V/T2, W/T3	14 - 2 (6 - 2)	20	
		-, +1, +2	14 - 2/0 (4 - 2/0)	20	1.5 - 1.7 (13.5 - 15)
		B1, B2	14 - 6 (14 - 6)	10	
		⊕	6 - 4 (-)	-	5.4 - 6.0 (47.8 - 53.1)

5 Main Circuit and Motor Wiring

Model	A1000 Model CIMR-AU	Terminal Symbol	Applicable Gauge (IP20 Applicable Gauge <I>) AWG, kcmil	Wire Strip Length mm	Tightening Torque N-m (lb-in)
	GA800 Catalog Code GA80U				
A1000	2A0110	R/L1, S/L2, T/L3	3 - 1/0	-	-
		U/T1, V/T2, W/T3			
		-, +1	2 - 1/0		
		B1, B2	6		
		⊥	6 - 4		
GA800	2110	R/L1, S/L2, T/L3	6 - 1/0 (6 - 1/0)	27	8 - 9 (71 - 80)
		U/T1, V/T2, W/T3		27	
		-, +1	2 - 2/0 (2 - 2/0)	27	10 - 12 (89 - 107)
		B1, B2	14 - 4 (10 - 4)	21	3 - 3.5 (27 - 31)
		⊥	6 - 4 (-)	-	5.4 - 6.0 (47.8 - 53.1)
A1000	2A0138	R/L1, S/L2, T/L3	1 - 2/0	-	-
		U/T1, V/T2, W/T3			
		-, +1	1/0 - 3/0		
		B1, B2	4 - 2/0		
		⊥	4		
GA800	2138	R/L1, S/L2, T/L3	6 - 2/0 (2 - 2/0)	27	8 - 9 (71 - 80)
		U/T1, V/T2, W/T3		27	
		-, +1	2 - 4/0 (2 - 4/0)	27	10 - 12 (89 - 107)
		B1, B2	14 - 3 (10 - 3)	21	3 - 3.5 (27 - 31)
		⊥	4 (-)	-	5.4 - 6.0 (47.8 - 53.1)
A1000	2A0169	R/L1, S/L2, T/L3	2/0 - 4/0	-	-
		U/T1, V/T2, W/T3	3/0 - 4/0		
		-, +1	1 - 4/0		
		+3	1/0 - 4/0		
		⊥	4 - 2		
GA800	2169	R/L1, S/L2, T/L3	2 - 250 (2/0 - 250)	37	12 - 14 (107 - 124)
		U/T1, V/T2, W/T3	2 - 300 (3/0 - 300)	37	
		-, -, +1, +1 *4 *5	6 - 2/0 (1/0 - 2/0)	28	8 - 9 (71 - 80)
		+3 *5	4 - 2/0 (1 - 2/0)	28	8 - 9 (71 - 80)
		⊥	4 - 1/0 (-)	-	9.0 - 11 (79.7 - 97.4)
A1000	2A0211	R/L1, S/L2, T/L3	1/0 - 2/0	-	-
		U/T1, V/T2, W/T3			
		-, +1	1 - 4/0		
		+3	1/0 - 4/0		
		⊥	4 - 1/0		
GA800	2211	R/L1, S/L2, T/L3	2 - 250 (2/0 - 250)	37	12 - 14 (107 - 124)
		U/T1, V/T2, W/T3	2 - 300 (3/0 - 300)	37	
		-, -, +1, +1 *4 *5	6 - 2/0 (1/0 - 2/0)	28	8 - 9 (71 - 80)
		+3 *5	4 - 2/0 (1 - 2/0)	28	
		⊥	4 - 1/0 (-)	-	9.0 - 11 (79.7 - 97.4)

5 Main Circuit and Motor Wiring

Model	A1000 Model CIMR-AU	Terminal Symbol	Applicable Gauge (IP20 Applicable Gauge <1>) AWG, kcmil	Wire Strip Length mm	Tightening Torque N-m (lb-in)
	GA800 Catalog Code GA80U				
A1000	2A0250	R/L1, S/L2, T/L3	3/0 - 300	-	-
		U/T1, V/T2, W/T3			
		-, +1			
		+3	2 - 300		
		⊕	3 - 300		
GA800	2257	R/L1, S/L2, T/L3	3 - 4/0 × 2P (2/0 - 4/0 × 2P)	-	20 (177)
		U/T1, V/T2, W/T3		-	
		-, +1	2 - 250 × 2P (4/0 - 250 × 2P)	-	
		+3	4 - 1/0 × 2P (1/0 × 2P)	-	
		⊕	3 - 350 (-)	-	18 - 23 (159 - 204)
A1000	2A0312	R/L1, S/L2, T/L3	3/0 - 300	-	-
		U/T1, V/T2, W/T3			
		-, +1			
		+3			
		⊕	2 - 300		
GA800	2313	R/L1, S/L2, T/L3	3 - 4/0 × 2P (2/0 - 4/0 × 2P)	-	20 (177)
		U/T1, V/T2, W/T3		-	
		-, +1	2 - 250 × 2P (4/0 - 250 × 2P)	-	
		+3	4 - 1/0 × 2P (1/0 × 2P)	-	
		⊕	2 - 350 (-)	-	18 - 23 (159 - 204)
A1000	2A0360	R/L1, S/L2, T/L3	4/0 - 600	-	-
		U/T1, V/T2, W/T3			
		-, +1	250 - 600		
		+3	3/0 - 600		
		⊕	1 - 350		
GA800	2360	R/L1, S/L2, T/L3	2/0 - 300 × 2P (250 - 300 × 2P)	-	35 (310)
		U/T1, V/T2, W/T3		-	
		-, +1	4/0 - 400 × 2P (300 - 400 × 2P)	-	
		+3	1/0 - 4/0 × 2P (-)	-	
		⊕	1 - 350 (-)	-	32 - 40 (283 - 354)
A1000	2A0415	R/L1, S/L2, T/L3	250 - 600	-	-
		U/T1, V/T2, W/T3			
		-, +1	300 - 600		
		+3	3/0 - 600		
		⊕	1 - 350		
GA800	2415	R/L1, S/L2, T/L3	2/0 - 300 × 2P (250 - 300 × 2P)	-	35 (310)
		U/T1, V/T2, W/T3		-	
		-, +1	4/0 - 400 × 2P (300 - 400 × 2P)	-	
		+3	1/0 - 4/0 × 2P (-)	-	
		⊕	1 - 350 (-)	-	32 - 40 (283 - 354)

<1> Use wires in the range of IP20 applicable gauge to meet the IP20 protective level.

Table 11 480 V Main Circuit Wire Gauge and Tightening Torques

Model	A1000 Model CIMR-AU	Terminal Symbol	Applicable Gauge (IP20 Applicable Gauge </>) AWG, kcmil	Wire Strip Length	Tightening Torque N•m (lb-in)
	GA800 Catalog Code GA80U				
A1000	4A0002 4A0004	R/L1,S/L2,T/L3	14 - 10	-	-
		U/T1, V/T2, W/T3			
		-, +1, +2			
		B1, B2			
		⊕			
	4A0005 4A0007 4A0009 4A0011	R/L1, S/L2, T/L3	14 - 10	-	-
		U/T1, V/T2, W/T3			
		-, +1, +2			
		B1, B2			
		⊕			
GA800	4002 4004 4005 4007 4009 4012	R/L1, S/L2, T/L3	14 - 6 (14 - 6)	10	1.5 - 1.7 (13.5 - 15)
		U/T1, V/T2, W/T3		10	
		-, +1, +2	14 - 3 (14 - 3)	18	2.3 - 2.5 (19.8 - 22)
		B1, B2	14 - 10 (14 - 10)	10	1.5 - 1.7 (13.5 - 15)
		⊕	14 - 8	-	1.2 - 1.5 (10.6-13.3)
		A1000	4A0018	R/L1, S/L2, T/L3	12 - 6
U/T1, V/T2, W/T3					
-, +1, +2					
B1, B2	12 - 10				
⊕	14 - 10				
GA800	4018	R/L1, S/L2, T/L3	14 - 6 (14 - 6)	10	1.5 - 1.7 (13.5 - 15)
		U/T1, V/T2, W/T3		10	
		-, +1, +2	14 - 3 (14 - 3)	18	2.3 - 2.5 (19.8 - 22)
		B1, B2	14 - 10 (14 - 10)	10	1.5 - 1.7 (13.5 - 15)
		⊕	14 - 8	-	1.2 - 1.5 (10.6-13.3)
A1000	4A0023	R/L1, S/L2, T/L3	10 - 6	-	-
		U/T1, V/T2, W/T3	12 - 6		
		-, +1, +2			
		B1, B2			
		⊕	12 - 10		
GA800	4023	R/L1, S/L2, T/L3	14 - 6 (14 - 6)	10	1.5 - 1.7 (13.5 - 15)
		U/T1, V/T2, W/T3		10	
		-, +1, +2	14 - 3 (14 - 3)	18	2.3 - 2.5 (19.8 - 22.1)
		B1, B2	14 - 10 (14 - 10)	10	1.5 - 1.7 (13.5 - 15)
		⊕	12 - 8	-	2.0 - 2.5 (17.7 - 22.1)

5 Main Circuit and Motor Wiring

Model	A1000 Model CIMR-AU	Terminal Symbol	Applicable Gauge (IP20 Applicable Gauge <I> AWG, kcmil	Wire Strip Length	Tightening Torque N•m (lb-in)
	GA800 Catalog Code GA80U				
A1000	4A0031	R/L1, S/L2, T/L3	8 - 6	-	-
		U/T1, V/T2, W/T3	10 - 6		
		-, +1, +2			
		B1, B2			
		⊥	10 - 8		
GA800	4031	R/L1, S/L2, T/L3	14 - 3 (8 - 3)	18	2.3 - 2.5 (19.8 - 22.1)
		U/T1, V/T2, W/T3	14 - 4 (10 - 4)	18	
		-, +1, +2	14 - 1 (8 - 1)	20	5 - 5.5 (45 - 49)
		B1, B2	14 - 8 (14 - 8)	10	1.5 - 1.7 (13.5 - 15)
		⊥	10 - 6	-	5.4 - 6.0 (47.8 - 53.1)
A1000	4A0038	R/L1, S/L2, T/L3	8 - 6	-	-
		U/T1, V/T2, W/T3			
		-, +1, +2	6		
		B1, B2	10 - 8		
		⊥	10 - 6		
GA800	4038	R/L1, S/L2, T/L3	14 - 3 (8 - 3)	18	2.3 - 2.5 (19.8 - 22.1)
		U/T1, V/T2, W/T3	14 - 4 (10 - 4)	18	
		-, +1, +2	14 - 1 (8 - 1)	20	5 - 5.5 (45 - 49)
		B1, B2	14 - 8 (14 - 8)	10	1.5 - 1.7 (13.5 - 15)
		⊥	10 - 6	-	5.4 - 6.0 (47.8 - 53.1)
A1000	4A0044	R/L1, S/L2, T/L3	6 - 4	-	-
		U/T1, V/T2, W/T3			
		-, +1, +2			
		B1, B2	10 - 8		
		⊥	8 - 6		
GA800	4044	R/L1, S/L2, T/L3	14 - 4 (10 - 4)	18	2.3 - 2.5 (19.8 - 22)
		U/T1, V/T2, W/T3	14 - 6 (10 - 6)	18	
		-, +1, +2	14 - 3 (10 - 3)	18	1.5 - 1.7 (13.5 - 15)
		B1, B2	14 - 8 (14 - 8)	10	
		⊥	8 - 4	-	
A1000	4A0058	R/L1, S/L2, T/L3	6 - 4	-	-
		U/T1, V/T2, W/T3			
		-, +1	6 - 1		
		B1, B2	8 - 4		
		⊥	8 - 6		
GA800	4060	R/L1, S/L2, T/L3	14 - 4 (10 - 4)	18	2.3 - 2.5 (19.8 - 22)
		U/T1, V/T2, W/T3		18	
		-, +1	14 - 3 (10 - 3)	18	1.5 - 1.7 (13.5 - 15)
		B1, B2	14 - 8 (14 - 8)	10	
		⊥	8 - 4	-	

5 Main Circuit and Motor Wiring

Model	A1000 Model CIMR-AU	Terminal Symbol	Applicable Gauge (IP20 Applicable Gauge <I>) AWG, kcmil	Wire Strip Length	Tightening Torque N·m (lb-in)
	GA800 Catalog Code GA80U				
A1000	4A0072	R/L1, S/L2, T/L3	4 - 3	-	-
		U/T1, V/T2, W/T3			
		-, +1	4 - 1		
		B1, B2	6 - 3		
		⊕	6		
GA800	4075	R/L1, S/L2, T/L3	14 - 3 (12 - 3)	18	2.3 - 2.5 (19.8 - 22)
		U/T1, V/T2, W/T3		18	
		-, +1	14 - 2 (10 - 2)	18	1.5 - 1.7 (13.5 - 15)
		B1, B2	14 - 6 (14 - 6)	10	
		⊕	6 - 4	-	
A1000	4A0088	R/L1, S/L2, T/L3	3 - 1/0	-	-
		U/T1, V/T2, W/T3			
		-, +1	6 - 1/0		
		+3			
		⊕	6 - 4		
GA800	4089	R/L1, S/L2, T/L3	14 - 2 (10 - 2)	18	2.3 - 2.5 (19.8 - 22)
		U/T1, V/T2, W/T3		18	
		-, +1	14 - 1/0 (6 - 1/0)	20	5 - 5.5 (45 - 49)
		B1, B2	14 - 6 (14 - 6)	18	2.3 - 2.5 (19.8 - 22)
		⊕	6 - 4	-	5.4 - 6.0 (47.8 - 53.1)
A1000	4A0103	R/L1, S/L2, T/L3	2 - 1/0	-	-
		U/T1, V/T2, W/T3			
		-, +1	3 - 1/0		
		+3	4 - 1/0		
		⊕	6 - 4		
GA800	4103	R/L1, S/L2, T/L3	6 - 2/0 (2 - 2/0)	27	8 - 9 (71 - 80)
		U/T1, V/T2, W/T3		27	
		-, +1	2 - 4/0 (2 - 4/0)	27	10 - 12 (89 - 107)
		B1, B2	14 - 3 (10 - 3)	21	3 - 3.5 (27 - 31)
		⊕	6 - 4	-	5.4 - 6.0 (47.8 - 53.1)
A1000	4A0139	R/L1, S/L2, T/L3	1/0 - 4/0	-	-
		U/T1, V/T2, W/T3			
		-, +1	3 - 4/0		
		+3			
		⊕	4		
GA800	4140	R/L1, S/L2, T/L3	2 - 250 (2/0 - 250)	37	12 - 14 (107 - 124)
		U/T1, V/T2, W/T3	2 - 300 (3/0 - 300)	37	
		-, +1	6 - 2/0 (1/0 - 2/0)	28	8 - 9 (71 - 80)
		B1, B2	4 - 2/0 (1 - 2/0)	28	8 - 9 (71 - 80)
		⊕	4 - 1/0	-	9.0 - 11 (79.7 - 97.4)







5 Main Circuit and Motor Wiring

Model	A1000 Model CIMR-AU	Terminal Symbol	Applicable Gauge (IP20 Applicable Gauge <I>) AWG, kcmil	Wire Strip Length	Tightening Torque N•m (lb-in)
	GA800 Catalog Code GA80U				
A1000	4A0165	R/L1, S/L2, T/L3	3/0 - 4/0	-	-
		U/T1, V/T2, W/T3			
		-, +1	1 - 4/0		
		+3	1/0 - 4/0		
		⊥	4		
GA800	4168	R/L1, S/L2, T/L3	2 - 250 (2/0 - 250)	37	12 - 14 (107 - 124)
		U/T1, V/T2, W/T3	2 - 300 (3/0 - 300)	37	
		-, +1	6 - 2/0 (1/0 - 2/0)	28	8 - 9 (71 - 80)
		B1, B2	4 - 2/0 (1 - 2/0)	28	
		⊥	4 - 1/0	-	9.0 - 11 (79.7 - 97.4)
A1000	4A0208	R/L1, S/L2, T/L3	2 - 300	-	-
		U/T1, V/T2, W/T3			
		-, +1	1 - 250		
		+3	3 - 3/0		
		⊥	4 - 300		
GA800	4208	R/L1, S/L2, T/L3	3 - 4/0 x 2P (2/0 - 4/0 x 2P)	-	20 (177)
		U/T1, V/T2, W/T3			
		-, +1	2 - 250 x 2P (4/0 - 250 x 2P)		
		+3	4 - 1/0 x 2P (1/0 x 2P)		
		⊥	4 - 350		-
A1000	4A0250	R/L1, S/L2, T/L3	1 - 600	-	-
		U/T1, V/T2, W/T3	1/0 - 600		
		-, +1	3/0 - 600		
		+3	1 - 325		
		⊥	2 - 350		
GA800	4250	R/L1, S/L2, T/L3	3 - 4/0 x 2P (2/0 - 4/0 x 2P)	-	20 (177)
		U/T1, V/T2, W/T3			
		-, +1	2 - 250 x 2P (4/0 - 250 x 2P)		
		+3	4 - 1/0 x 2P (1/0 x 2P)		
		⊥	2 - 350		-
A1000	4A0296	R/L1, S/L2, T/L3	2/0 - 600	-	-
		U/T1, V/T2, W/T3			
		-, +1	3/0 to 600		
		+3	1 - 325		
		⊥	2 - 350		
GA800	4302	R/L1, S/L2, T/L3	3 - 4/0 x 2P (2/0 - 4/0 x 2P)	-	20 (177)
		U/T1, V/T2, W/T3			
		-, +1	2 - 250 x 2P (4/0 - 250 x 2P)		
		+3	4 - 1/0 x 2P (1/0 x 2P)		
		⊥	2 - 350		-

5 Main Circuit and Motor Wiring

Model	A1000 Model CIMR-AU	Terminal Symbol	Applicable Gauge (IP20 Applicable Gauge <I>) AWG, kcmil	Wire Strip Length	Tightening Torque N·m (lb-in)
	GA800 Catalog Code GA80U				
A1000	4A0362	R/L1, S/L2, T/L3	3/0 - 600	-	-
		U/T1, V/T2, W/T3			
		-, +1	4/0 - 600		
		+3	3/0 - 600		
		⊕	1 - 350		
GA800	4371	R/L1, S/L2, T/L3	2/0 - 300 x 2P (250 - 300 x 2P)	-	35 (310)
		U/T1, V/T2, W/T3		-	
		-, +1	4/0 - 400 x 2P (300 - 400 x 2P)	-	
		+3	1 - 4/0 x 2P	-	
		⊕	1 - 350	-	32 - 40 (283 - 354)
A1000	4A0414	R/L1, S/L2, T/L3	4/0 - 300	-	-
		U/T1, V/T2, W/T3			
		-, +1	3/0 - 300		
		+3			
		⊕	1 - 3/0		
GA800	4414	R/L1, S/L2, T/L3	2/0 - 300 x 2P (250 - 300 x 2P)	-	35 (310)
		U/T1, V/T2, W/T3		-	
		-, +1	4/0 - 400 x 2P (300 - 400 x 2P)	-	
		+3	1 - 4/0 x 2P	-	
		⊕	1 - 350	-	32 - 40 (283 - 354)
GA800	4477	R/L1, S/L2, T/L3	2/0 - 300 x 4P (250 - 300 x 4P)	-	35 (310)
		U/T1, V/T2, W/T3		-	
		-, +1	3/0 - 400 x 4P (300 - 400 x 4P)	-	
		+3	2 - 4/0 (4/0 x 4P)	-	
		⊕	1/0 - 300	-	32 - 40 (283 - 354)
A1000	4A0515	R/L1, S/L2, T/L3	3/0 - 300	-	-
		U/T1, V/T2, W/T3			
		-, +1	1/0 - 300		
		+3			
		⊕			
GA800	4568	R/L1, S/L2, T/L3	2/0 - 300 x 4P (250 - 300 x 4P)	-	35 (310)
		U/T1, V/T2, W/T3		-	
		-, +1	3/0 - 400 x 4P (300 - 400 x 4P)	-	
		+3	2 - 4/0 x 4P (4/0 x 4P)	-	
		⊕	2/0 - 300	-	32 - 40 (283 - 354)
A1000	4A0675	R/L1, S/L2, T/L3	4/0 - 300	-	-
		U/T1, V/T2, W/T3			
		-, +1	1/0 - 300		
		+3			
		⊕			

5 Main Circuit and Motor Wiring







Model	A1000 Model CIMR-AU	Terminal Symbol	Applicable Gauge (IP20 Applicable Gauge <I> AWG, kcmil	Wire Strip Length	Tightening Torque N·m (lb-in)
	GA800 Catalog Code GA80U				
GA800	4605	R/L1, S/L2, T/L3	2/0 - 300 × 4P (250 - 300 × 4P)	-	35 (310)
		U/T1, V/T2, W/T3		-	
		-, +1	3/0 - 400 × 4P (300 - 400 × 4P)	-	
		+3	2 - 4/0 × 4P (4/0 × 4P)	-	
			2/0 - 300	-	
GA800	4720	R/L1, S/L2, T/L3	2/0 - 300 × 4P (250 - 300 × 4P)	-	35 (310)
		U/T1, V/T2, W/T3		-	
		-, +1	3/0 - 400 × 4P (300 - 400 × 4P)	-	
		+3	2 - 4/0 × 4P (4/0 × 4P)	-	
			2/0 - 300	-	
A1000	4A0930	R/L1, S/L2, T/L3 R1/L11, S1/L21, T1/L31	3/0 to 300	-	-
		U/T1, V/T2, W/T3			
		-, +1	4/0 to 300		
		+3			
			3/0 to 250		
GA800	4810	R/L1, S/L2, T/L3 R1/L11, S1/L21, T1/L31	2/0 - 300 × 4P × 2	-	35 (310)
		U/T1, V/T2, W/T3		-	
		-, +1	3/0 - 300 × 4P × 2	-	
		+3	1/0 - 300 × 4P × 2	-	
			3/0 - 250	-	
GA800	4930	R/L1, S/L2, T/L3 R1/L11, S1/L21, T1/L31	3/0 - 300 × 4P × 2	-	35 (310)
		U/T1, V/T2, W/T3		-	
		-, +1	3/0 - 300 × 4P × 2	-	
		+3	1/0 - 300 × 4P × 2	-	
			3/0 - 250	-	
A1000	4A1200	R/L1, S/L2, T/L3 R1/L11, S1/L21, T1/L31	4/0 to 300	-	-
		U/T1, V/T2, W/T3			
		-, +1	250 to 300		
		+3			
			4/0 to 250		
GA800	4H11	R/L1, S/L2, T/L3 R1/L11, S1/L21, T1/L31	4/0 - 300 × 4P × 2	-	35 (310)
		U/T1, V/T2, W/T3		-	
		-, +1	250 - 300 × 4P × 2	-	
		+3	1/0 - 300 × 4P × 2	-	
			4/0 - 250	-	

5 Main Circuit and Motor Wiring

Model	A1000 Model CIMR-AU	Terminal Symbol	Applicable Gauge (IP20 Applicable Gauge <I>) AWG, kcmil	Wire Strip Length	Tightening Torque N·m (lb-in)
	GA800 Catalog Code GA80U				
GA800	4H12	R/L1, S/L2, T/L3 R1/L11, S1/L21, T1/L31	4/0 - 300 × 4P × 2	-	35 (310)
		U/T1, V/T2, W/T3		-	
		-, +1	250 - 300 × 4P × 2	-	
		+3	2/0 - 300 × 4P × 2	-	
			4/0 - 250	-	

<I> Use cables in the range of IP20 applicable gauges to meet the IP20 protective level.

Table 12 600 V Main Circuit Wire Gauge and Tightening Torques

Model	A1000 Model CIMR-AU	Terminal Symbol	Applicable Gauge (IP20 Applicable Gauge <I>) AWG, kcmil	Wire Strip Length	Tightening Torque N·m (lb-in)
	GA800 Catalog Code GA80U				
A1000	5A0003 5A0004 5A0006	R/L1, S/L2, T/L3	14 - 10	-	-
		U/T1, V/T2, W/T3			
		-, +1, +2			
		B1, B2			
					
A1000	5A0009	R/L1,S/L2,T/L3	14 - 10	-	-1.2 -1.5 (10.6 - 13.3)
		U/T1, V/T2, W/T3			
		-, +1, +2			
		B1, B2	12 - 10		
					
GA800	5002 5003 5004 5006 5009	R/L1,S/L2,T/L3	14 - 6 (14 - 6)	10	1.5 - 1.7 (13.5 - 15)
		U/T1, V/T2, W/T3	14 - 6 (14 - 6)	10	
		-, +1, +2	14 - 3 (14 - 3)	18	2.3 - 2.5 (19.8 - 22)
		B1, B2	14 - 10 (14 - 10)	10	1.5 - 1.7 (13.5 - 15)
			10 - 8 (-)	-	2.0 - 2.5 (17.7 - 22.1)
A1000	5A0011	R/L1,S/L2,T/L3	14 - 6	--	
		U/T1, V/T2, W/T3			
		-, +1, +2			
		B1, B2	14 - 10		
			12 - 8		
GA800	5011	R/L1,S/L2,T/L3	14 - 6 (14 - 6)	10	1.5 - 1.7 (13.5 - 15)
		U/T1, V/T2, W/T3		10	
		-, +1, +2	14 - 3 (14 - 3)	18	2.3 - 2.5 (19.8 - 22)
		B1, B2	14 - 10 (14 - 10)	10	1.5 - 1.7 (13.5 - 15)
			8 - 6 (-)	-	2.0 - 2.5 (17.7 - 22.1)
A1000	5A0017	R/L1,S/L2,T/L3	10 - 6	-	-
		U/T1, V/T2, W/T3			
		-, +1, +2			
		B1, B2	10 - 8		
			12 - 8		

5 Main Circuit and Motor Wiring

Model	A1000 Model CIMR-AU	Terminal Symbol	Applicable Gauge (IP20 Applicable Gauge <I> AWG, kcmil	Wire Strip Length	Tightening Torque N•m (lb-in)
	GA800 Catalog Code GA80U				
GA800	5017	R/L1,S/L2,T/L3	14 - 3 (8 - 3)	18	2.3 - 2.5 (19.8 - 22)
		U/T1, V/T2, W/T3	14 - 4 (10 - 4)	18	
		-, +1, +2	14 - 1 (8 - 1)	20	5 - 5.5 (45 - 49)
		B1, B2	14 - 8 (14 - 8)	10	1.5 - 1.7 (13.5 - 15)
		⊥	8 - 6 (-)	-	5.4 - 6.0 (47.8 - 53.1)
A1000	5A0022	R/L1,S/L2,T/L3	10 - 6	-	-
		U/T1, V/T2, W/T3			
		-, +1, +2	10 - 6		
		B1, B2	10 - 8		
		⊥	10 - 6		
GA800	5022	R/L1,S/L2,T/L3	14 - 3 (8 - 3)	18	2.3 - 2.5 (19.8 - 22)
		U/T1, V/T2, W/T3	14 - 4 (10 - 4)	18	
		-, +1, +2	14 - 1 (8 - 1)	20	5 - 5.5 (45 - 49)
		B1, B2	14 - 8 (14 - 8)	10	1.5 - 1.7 (13.5 - 15)
		⊥	8 - 6 (-)	-	5.4 - 6.0 (47.8 - 53.1)
A1000	5A0027 5A0032	R/L1,S/L2,T/L3	6 - 4	-	-
		U/T1, V/T2, W/T3			
		-, +1, +2	10 - 8		
		B1, B2			
		⊥	10 - 6		
GA800	5027 5032	R/L1,S/L2,T/L3	14 - 4 (10 - 4)	18	2.3 - 2.5 (19.8 - 22)
		U/T1, V/T2, W/T3	14 - 6 (10 - 6)	18	
		-, +1, +2	14 - 3 (10 - 3)	18	
		B1, B2	14 - 8 (14 - 8)	10	1.5 - 1.7 (13.5 - 15)
		⊥	6 - 4 (-)	-	5.4 - 6.0 (47.8 - 53.1)
A1000	5A0041	R/L1,S/L2,T/L3	10 - 3	-	-
		U/T1, V/T2, W/T3			
		-, +1, +2	6 - 1		
		B1, B2	12 - 3		
		⊥	6		
GA800	5041	R/L1, S/L2, T/L3	14 - 13 (12 - 3)	20	5 - 5.5 (45 - 49)
		U/T1, V/T2, W/T3	14 - 3 (6 - 3)	20	
		-, +1	14 - 1/0 (4 - 1/0)	20	
		B1, B2	14 - 8 (14 - 8)	10	1.5 - 1.7 (13.5 - 15)
		⊥	6 - 4 (-)	-	5.4 - 6.0 (47.8 - 53.1)
A1000	5A0052	R/L1, S/L2, T/L3	10 - 3	-	-
		U/T1, V/T2, W/T3			
		-, +1, +2	6 - 1		
		B1, B2	8 - 3		
		⊥	6		

5 Main Circuit and Motor Wiring

Model	A1000 Model CIMR-AU	Terminal Symbol	Applicable Gauge (IP20 Applicable Gauge <I>) AWG, kcmil	Wire Strip Length	Tightening Torque N·m (lb-in)	
	GA800 Catalog Code GA80U					
GA800	5052	R/L1, S/L2, T/L3	14 - 13 (12 - 3)	18	2.3 - 2.5 (19.8 - 22)	
		U/T1, V/T2, W/T3				
		-, +1	14 - 2 (10 - 2)	18		
		B1, B2	14 - 6 (14 - 6)	10		1.5 - 1.7 (13.5 - 15)
		⊕	6 - 4 (-)	-		5.4 - 6.0 (47.8 - 53.1)
A1000	5A0062	R/L1, S/L2, T/L3	10 - 4/0	-	-	
		U/T1, V/T2, W/T3				
		-, +1	4 - 4/0			
		B1, B2	6 - 4/0			
		⊕	4			
GA800	5062	R/L1, S/L2, T/L3	2 - 300 (2/0 - 250)	37	12 - 14 (107 - 124)	
		U/T1, V/T2, W/T3	2 - 300 (3/0 - 300)			
		-, -, +1, +1	3 - 2/0 (1/0 - 2/0)	28		8 - 9 (71 - 80)
		B1, B2	4 - 3/0 (1 - 2/0)	28		8 - 9 (71 - 80)
		⊕	6 - 250 (-)	-		9.0 - 11 (79.7 - 97.4)
A1000	5A0077	R/L1, S/L2, T/L3	10 - 4/0	-	-	
		U/T1, V/T2, W/T3				
		-, +1	3 - 4/0			
		+3	6 - 4/0			
		⊕	4			
GA800	5077	R/L1, S/L2, T/L3	2 - 300 (2/0 - 250)	37	12 - 14 (107 - 124)	
		U/T1, V/T2, W/T3	2 - 300 (3/0 - 300)			
		-, -, +1, +1	3 - 2/0 (1/0 - 2/0)	28		8 - 9 (71 - 80)
		B1, B2	4 - 3/0 (1 - 2/0)	28		8 - 9 (71 - 80)
		⊕	6 - 250 (-)	-		9.0 - 11 (79.7 - 97.4)
A1000	5A0099	R/L1, S/L2, T/L3	10 - 4/0	-	-	
		U/T1, V/T2, W/T3	10 - 4/0			
		-, +1	2 - 4/0			
		+3	4 - 4/0			
		⊕	4			
GA800	5099	R/L1, S/L2, T/L3	2 - 300 (2/0 - 250)	37	12 - 14 (107 - 124)	
		U/T1, V/T2, W/T3	2 - 300 (3/0 - 300)	37		
		-, -, +1, +1	2 - 2/0 (1/0 - 2/0)	28		8 - 9 (71 - 80)
		B1, B2	4 - 3/0 (1 - 2/0)	28		8 - 9 (71 - 80)
		⊕	6 - 250 (-)	-		9.0 - 11 (79.7 - 97.4)
A1000	5A0125	R/L1, S/L2, T/L3	1 - 300	-	-	
		U/T1, V/T2, W/T3				
		-, +1	2/0 - 3/0			
		+3	1 - 1/0			
		⊕	3 - 300			

5 Main Circuit and Motor Wiring

Model	A1000 Model CIMR-AU	Terminal Symbol	Applicable Gauge (IP20 Applicable Gauge <1> AWG, kcmil	Wire Strip Length	Tightening Torque N·m (lb-in)	
	GA800 Catalog Code GA80U					
GA800	5125	R/L1, S/L2, T/L3	1 - 4/0 × 2P (2/0 - 4/0 × 2P)	-	20 (177)	
		U/T1, V/T2, W/T3		-		
		-, +1	2/0 - 250 × 2P (4/0 - 250 × 2P)	-		
		+3	3 - 1/0 × 2P (1/0 × 2P)	-		
		⊥	3 - 300 (-)	-		18 - 23 (159 - 204)
A1000	5A0145	R/L1,S/L2,T/L3	2/0 - 300	-	-	
		U/T1, V/T2, W/T3				
		-, +1	3/0 - 4/0			
		+3	1/0 - 2/0			
		⊥	3 - 300			
GA800	5144	R/L1, S/L2, T/L3	1 - 4/0 × 2P (2/0 - 4/0 × 2P)	-	20 (177)	
		U/T1, V/T2, W/T3	2/0 - 4/0 × 2P (2/0 - 4/0 × 2P)	-		
		-, +1	3/0 - 250 × 2P (4/0 - 250 × 2P)	-		
		+3	3 - 1/0 × 2P (1/0 × 2P)	-		
		⊥	3 - 300 (-)	-		18 - 23 (159 - 204)
A1000	5A0192	R/L1, S/L2, T/L3	2/0 - 600	-	-	
		U/T1, V/T2, W/T3				
		-, +1	2/0 - 400			
		+3	2/0 - 250			
		⊥	1 - 350			
GA800	5192	R/L1, S/L2, T/L3	3/0 - 300 × 2P (250 - 300 × 2P)	-	35 (310)	
		U/T1, V/T2, W/T3	2/0 - 300 × 2P (250 - 300 × 2P)	-		
		-, +1	1 - 400 × 2P (300 - 400 × 2P)	-		
		+3	3 - 300 × 2P	-		
		⊥	1 - 350 (-)	-		32 - 40 (283 - 354)
A1000	5A0242	R/L1,S/L2,T/L3	2/0 - 600	-	-	
		U/T1, V/T2, W/T3				
		-, +1	2/0 - 500			
		+3	250 - 300			
		⊥	1 - 350			
GA800	5242	R/L1, S/L2, T/L3	2/0 - 300 × 2P (250 - 300 × 2P)	-	35 (310)	
		U/T1, V/T2, W/T3				
		-, +1	1 - 400 × 2P (300 - 400 × 2P)			-
		+3	3 - 300 × 2P			-
		⊥	1 - 350 (-)			-

<1> Use cables in the range of IP20 applicable gauges to meet the IP20 protective level.

6 Control Circuit Wiring

Use this section to transfer A1000 control circuit wiring to the GA800. Refer to the GA800 Installation & Primary Operation Manual or Technical Reference for more details and precautions when wiring the GA800 control circuit terminals.

◆ Control Circuit Terminal Layout

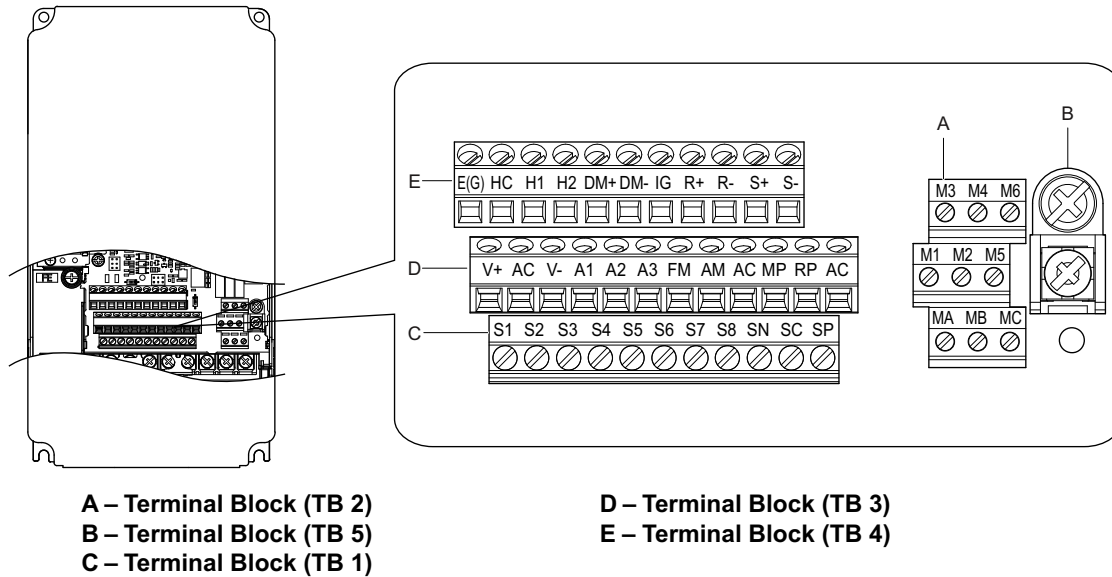

Figure 2 A1000 Control Circuit Terminals

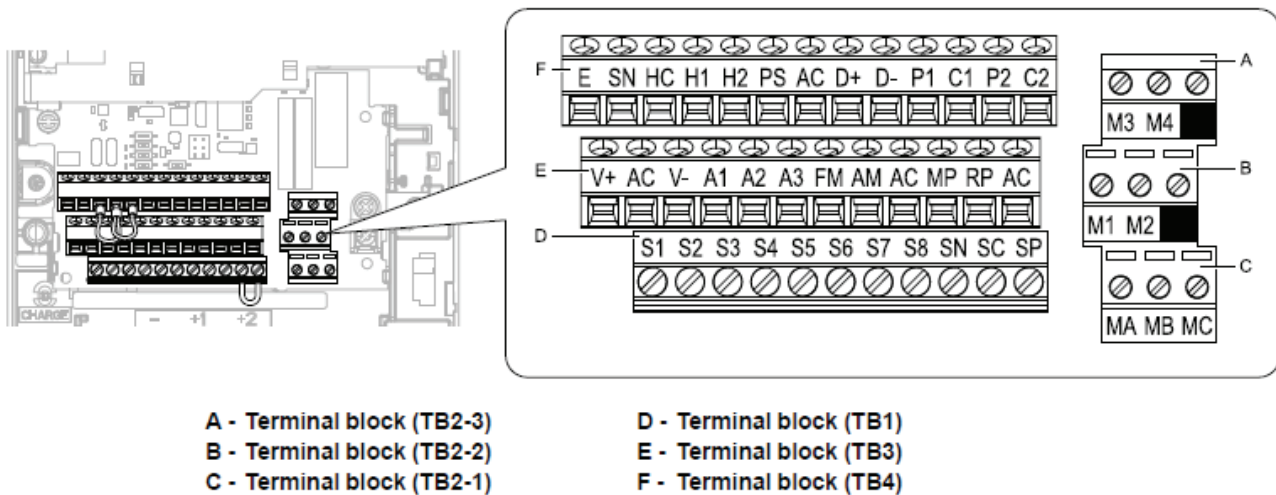

Figure 3 GA800 Control Circuit Terminals

6 Control Circuit Wiring

◆ Control Circuit I/O Cross Reference

Refer to the GA800 Installation & Primary Operation Manual or Technical Reference for more details and precautions when wiring the GA800 control circuit terminals.

Table 13 Control Circuit I/O Cross Reference

Control Circuit Terminals		Name	Signal Level	
A1000	GA800		A1000	GA800
S1	S1	Multi-function input 1 (ON: Forward run OFF: Stop)	Photocoupler 24 Vdc, 8 mA	Photocoupler 24 Vdc, 6 mA
S2	S2	Multi-function input 2 (ON: Reverse run OFF: Stop)		
S3	S3	Multi-function input 3 (External fault (N.O.))		
S4	S4	Multi-function input 4 (Fault reset)		
S5	S5	Multi-function input 5 (Multi-step speed reference 1)		
S6	S6	Multi-function input 6 (Multi-step speed reference 2)		
S7	S7	Multi-function input 7 (Jog command)		
S8	S8	Multi-function input 8 (Baseblock command (N.O.))		
SC	SN	Multi-function input power supply 0 V	Multi-function Input common	Notice: Do not jumper or short terminals SP and SN. Failure to comply will damage the drive.
	SC	Multi-function input common		
	SP	Digital input power supply +24 Vdc		MFDI power supply, 24 V (maximum 150 mA)
RP	RP	Multi-function pulse train input	Response frequency 0.5 - 32 kHz (3 kΩ)	Response frequency 0.0 - 32 kHz (3 kΩ)
+V	+V	Power supply for analog inputs	+10.5 V (maximum allowable current 20 mA)	
-V	-V	Power supply for analog inputs	-10.5 V (maximum allowable current 20 mA)	
A1	A1	Multi-function analog input 1	-10 to +10 Vdc 0 to 10 Vdc (20 kΩ)	-10 to +10 Vdc 0 to 10 Vdc (20 kΩ) 4 to 20 mA (250 Ω) 0 to 20 mA (250 Ω)
A2	A2	Multi-function analog input 2	-10 to +10 Vdc 0 to 10 Vdc (20 kΩ) 4 to 20 mA (250 Ω) 0 to 20 mA (250 Ω)	Voltage Input or Current Input: • Select terminal A1 using DIP switch S1-1 and H3-01 [Terminal A1 Signal Level Select] • Select terminal A2 using DIP switch S1-2 and H3-09 [Terminal A2 Signal Level Select]
A3	A3	Multi-function analog input 3	-10 to +10 Vdc 0 to 10 Vdc (20 kΩ) Use DIP switch S4 on the terminal board to select between analog and PTC input.	-10 to +10 Vdc 0 to +10 Vdc (20 kΩ) 4 - 20 mA (250 Ω) 0 - 20 mA (250 Ω) Voltage Input or Current Input: • Select using DIP switch S1-3 and H3-05 [Terminal A3 Signal Level Select]. • PTC input (Motor Overheat Protection) Set DIP switch S4 to "PTC" and set DIP switch S1-3 to "V" to set terminal A3 for PTC input.

Control Circuit Terminals		Name	Signal Level	
A1000	GA800		A1000	GA800
AC	AC	Frequency reference common	0 V	
E (G)	E (G)	Ground for shielded lines and option cards	-	
H1	H1	Safe Disable input 1	<ul style="list-style-type: none"> • 24 Vdc, 8 mA • Closed: Normal operation • Open: Coasting motor Internal impedance 3.3 kΩ • OFF time of at least 1 ms 	Remove the jumper between terminals H1-HC and H2-HC when using the Safe Disable input. <ul style="list-style-type: none"> • 24 Vdc, 6 mA • ON: Normal operation • OFF: Coasting motor • Internal impedance 4.7 kΩ • OFF time of at least 2 ms
H2	H2	Safe Disable input 2		
HC	HC	Safe Disable function common	Safe Disable function common	Safe Disable function common NOTICE: Do not short terminals HC and SN. Failure to comply will damage the drive.
DM+	<I>	Safety monitor output	+48 Vdc 50 mA	<I>
DM-	<I>	Safety monitor output		
MA	MA	N.O. output (Fault)	Fault relay output	
MB	MB	N.C. output (Fault)	30 Vdc 10 mA - 1A	
MC	MC	Fault output common	250 Vac 10 mA - 1A	
M1	M1	Multi-function digital output (During run)	Multi-function digital output 30 Vdc 10 mA - 1A 250 Vac 10 mA - 1A	
M2	M2			
M3	M3	Multi-function digital output (Zero speed)	Multi-function digital output 30 Vdc 10 mA - 1A 250 Vac 10 mA - 1A	
M4	M4			
M5	M5	Multi-function digital output (Speed Agree 1)	Multi-function digital output 30 Vdc 10 mA - 1A 250 Vac 10 mA - 1A	
M6	M6			
MP	MP	Pulse train output (Output frequency)	32 kHz (2.2 kΩ) maximum	
FM	FM	Analog monitor output 1 (Output frequency)	-10 to +10 Vdc (current 2 mA)	-10 to +10 Vdc 0 to 10 V (current 2 mA)
AM	AM	Analog monitor output 2 (Output current)	Resolution: 1/1000	4 to 20 mA Select voltage or current output.
-	PS	External 24 V power supply input	-	21.6 Vdc to 26.4 Vdc, 700 mA
AC	AC	Monitor common External 24 V power supply ground	0 V	
Serial Communication Terminal		Name	Signal Level	
A1000	GA800		A1000	GA800
R+	D+	A1000: Communications input (+) GA800: Communications input/output (+)	Differential input Photocoupler insulation Use an RS-485 or RS-422 cable to connect the drive.	Differential input Photocoupler insulation Use an RS-485 cable to connect the drive.
R-	D-	A1000: Communications input (-) GA800: Communications input/output (-)		
S+	D+	A1000: Communications output (+) GA800: Communications input/output (+)		
S-	D-	A1000: Communications output (-) GA800: Communications input/output (-)		
IG	AC	Shield ground	0 V	0 V

<I> Transfer wiring from the DM+ and DM- terminals on A1000 to terminals M1 and M2 or to M3 and M4 on GA800.

6 Control Circuit Wiring

Table 14 Control Circuit Terminal Sizes and Wire Gauge

Model	Capacity	Terminal Symbol	Screw	Tightening Torque N•m (lb-in)	Wire Range mm ² (AWG)	Recommended Gauge mm ² (AWG)
A1000	All Capacities	FM, AC, AM, SC, A1, A2, A3, +V, -V, S1-S8, SN, SP, MA, MB, MC, M1-M6, H1, H2, HC, R+, R-, S+, S-, IG, DM+, DM-	M3	0.8 to 1.0 (7 to 9)	0.5 to 2.0 (20 to 14)	0.75 (18)
		MP, RP	M2 PHOENIX Type	0.22 to 0.25 (1.9 to 2)	Stranded Wire 0.25 to 1.0 (24 to 20) Solid Wire 0.25 to 1.5 (24 to 16)	0.75 (18)
		E (G)	M3.5	0.8 to 1.0 (7 to 9)	0.5 to 2.0 (20 to 14)	1.25 (12)
GA800	All Capacities	FM, AC, AM, SN, SC, SP, A1, A2, A3, +V, -V, S1-S8, MA, MB, MC, M1-,M6, MP, RP, D+, D-, H1, H2, HC, PS	M3 PHOENIX Type	0.5 to 0.6 (4.4 to 5.3)	Stranded Wire 0.2 to 1.0 (24 to 16) Solid Wire 0.2 to 1.5 (24 to 16)	0.75 (18)
		E(G)	M3.5	0.5 - 1.0 (4.4 - 8.9)	0.5 - 2 (20- 14)	1.25 (12)

◆ Control Circuit Switches and Jumpers

Use this section to make any needed changes to the GA800 control circuit switches or jumpers.

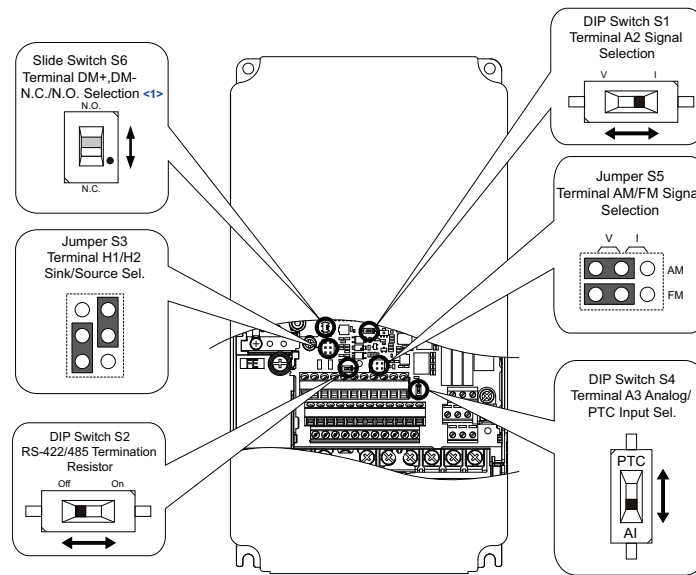

<1> Slide switch S6 selects N.C. or N.O. as the state of the DM+ and DM- terminals for EDM output. Slide switch S6 is available on removable terminal circuit boards ETC740300, ETC740301 and later.

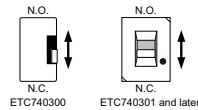
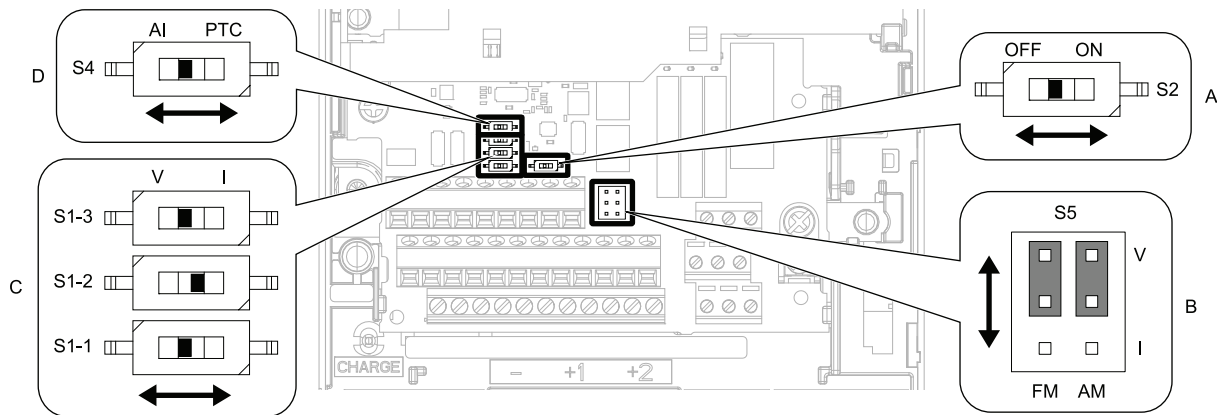

Figure 4 A1000 Switches and Jumpers



	Switch	Terminal	Function	Default Setting
A	DIP switch S2	-	Enables and disables the MEMOBUS/Modbus communications termination resistor.	OFF
B	Jumper switch S5	FM, AM	Sets terminals FM and AM to voltage or current output.	FM: V (voltage output) AM: V (voltage output)
C	DIP switch S1-1	A1	Selects the input signal type (voltage/current).	V (voltage input)
	DIP switch S1-2	A2	Selects the input signal type (voltage/current).	I (current input)
	DIP switch S1-3	A3	Selects the input signal type (voltage/current).	V (voltage input)
D	Dip switch S4	A3	Selects MFAI or PTC input.	AI (analog input)

Figure 5 GA800 Switches and Jumpers

7 Transfer of Parameter Settings

Use this section to transfer A1000 parameter settings to the GA800. There are several methods to transfer parameters.

- **Transfer Parameters via DriveWizard Industrial PC Software on page 42** (recommended)
Yaskawa recommends the use of DriveWizard Industrial to transfer parameters.
- **Procedure - Transfer A1000 Parameters to GA800 Manually via Keypad on page 44** (manual procedure)

◆ Transfer Parameters via DriveWizard Industrial PC Software

The DriveWizard® Industrial support tool is a Windows-based PC program designed to make commissioning and troubleshooting of Yaskawa drives as simple as possible. DriveWizard® Industrial provides user-friendly tools for viewing, manipulating, and exchanging data with the drive. Data can be retrieved, changed, stored, and graphed. DriveWizard® Industrial is also used to transfer parameters from previous generation drives to new ones. T

DriveWizard Industrial is compatible with the GA800, A1000, P1000, U1000, V1000, V1000-4X, J1000, D1000, R1000, F7, P7, G7 and G5 Low HP.

Request a free copy of DriveWizard Industrial PC software here:

<https://www.yaskawa.com/ad-campaign?promoCode=drivewizard-industrial>

DriveWizard Industrial product page on yaskawa.com:

<https://www.yaskawa.com/products/drives/industrial-ac-drives/industrial-software-tools/drivewizard-industrial>



The screenshot shows the "Drive Converter" software window. The title bar reads "Drive Converter". Below the title bar, there is a description: "This function allows users to convert from one drive series to another drive series." and a link "Getting Started". Below that, it says "Create or open an existing project, next go to the Tool menu and click on Project Converter." The main area contains a "Drive Conversion" dialog box with two tabs: "Conversion Selection" and "Conversion Log". The "Conversion Selection" tab is active and shows "Drive Information" with fields for "Drive Series: A1000", "Software Version: 1026", "Model: CIMR-A*2*0004***", and "Control Method: Open Loop Vector". To the right, there is a "Drive Duty Cycle" section with radio buttons for "Normal Duty" (selected), "Normal Duty 2", and "Heavy Duty". Below this, there is a section "Select drive series, software version and model to convert to:" with dropdown menus for "Drive Series: GA800", "Software Version: 09010", and "Model: CIPR-GA80*2004****". A "Go!" button is located to the right of these dropdowns. At the bottom of the dialog, there are two checkboxes: "Convert non-KVA related parameters only" and "Convert modified parameters only". Below the dialog, there is an "Important please read:" section with a warning message and a "Please verify all parameters after conversion is completed." note. At the bottom of the window, there are buttons for "Help", "Transfer converted data to the active project", and "Cancel".

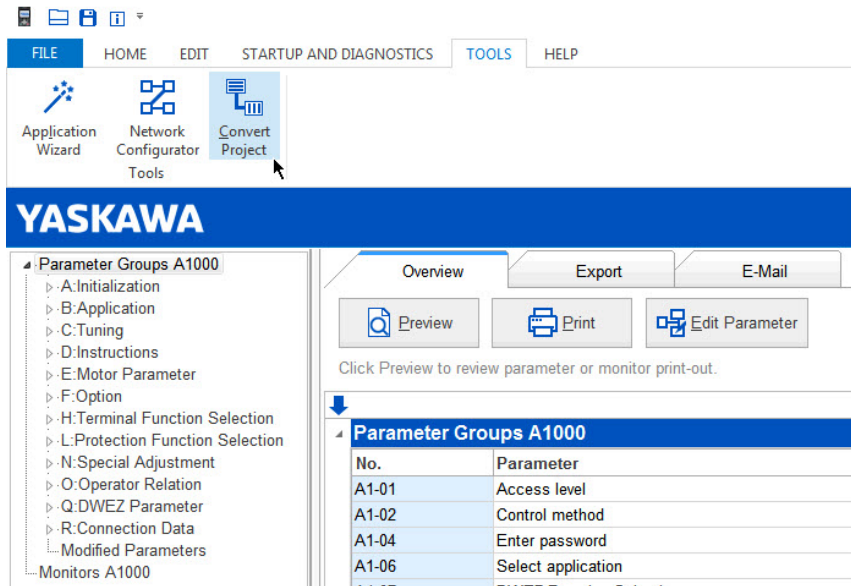

■ About DriveWizard Mobile for Android and iOS

DriveWizard Mobile is DriveWizard for mobile devices. It does not have a feature to transfer parameters between A1000 and GA800, but it is very useful for commissioning GA800 drives with your smartphone or tablet.

Start-up, adjust, and monitor Yaskawa GA800 AC drives with your smartphone or tablet. Use DriveWizard® Mobile to backup, store, and retrieve your drive settings locally or to your personal Yaskawa Drive Cloud™ account. DriveWizard Mobile is the mobile app version of DriveWizard® Industrial.

Get DriveWizard Mobile here: <https://www.yaskawa.com/dwm>

Get the App



DriveWizard Mobile for Android



► Requires 4.4 or later





DriveWizard Mobile for iOS



► Requires iOS 10.0 or later
► Compatible with iPhone, iPad, and iPod Touch



◆ Procedure - Transfer A1000 Parameters to GA800 Manually via Keypad

1. Energize the A1000.
 2. Use the UP or DOWN arrow key to scroll to the “Modified Consts” menu.
 3. Press the ENTER key.
 4. If no parameters were changed from their default settings if the display shows:
“Modified Consts”
“Non Modified”
If parameters are modified the A1000 display will read:
“Modified Consts”
“Modified”
“X Parameters” where X=the number of modified parameters.
 5. Press the ENTER key to display the current parameter setting.
 6. Note the modified parameter number and setting.
 7. Press the ESC key. The display returns to the flashing parameter.
 8. Press the UP arrow key.
 9. If other parameters have been changed from the default settings, the parameters will flash, and appear in alphabetical order.
 10. The display will return to the first parameter that was displayed after scrolling through all parameters that have been changed from the default setting. Note any A1000 modified parameters for transfer to the GA800.
 11. De-energize the A1000.
- Note:** The following parameters will not appear in the “Modified Constants” Menu if they have been changed from their default settings:
- A1-□□ (except for A1-02 [Control Method Selection])
 - A2-01 through A2-32
 - E5-01 [Motor Code Selection (for PM Motors)]
12. The next step is performed after the GA800 is installed according to the GA800 Installation & Primary Operation Manual.
 13. Follow all safety precautions in the GA800 manual and apply main power to the GA800.
 14. From the Initial Display press the F2 (Home) soft key.
 15. Press the F2 (Menu) soft key. Scroll down using the down arrow to the “Parameters” menu. Press the Enter key.
 16. From this display you can access all the GA800 parameters and transfer the settings manually that were modified in the A1000.
 17. Change the setting value of A1-01 [Access Level Selection] in GA800 to 3 [Expert Level].
 18. Access the GA800 parameters and transfer the noted settings manually that were modified in the A1000.
END.

◆ Parameters with Default Value or Setting Range Differences

Some of the setting ranges and default settings for certain parameters differ between A1000 and GA800.

Note: The parameter numbers for terminals P1 and P2 are different in GA800.

- H2-02 in A1000 matches H2-03 in GA800.
- H2-03 in A1000 matches H2-04 in GA800.

Table 15 only lists **setting range or default setting differences** between similar A1000 and GA800 parameters. **Table 15** is not a comprehensive comparison of all parameter differences between A1000 and GA800. For example, GA800 parameters that have no equal in the A1000 are omitted.

Table 15 Parameters with Setting Range or Default Value Differences

Parameter No.	Name	A1000		GA800	
		Default Setting	Setting Range	Default Setting	Setting Range
A1-01	Access Level Selection	2	0: Operation Only 1: User Parameters 2: Advanced Level	2	0: Operation Only 1: User Parameters 2: Advanced Level 3: Expert Level
A1-02	Control Method Selection	2	0: V/f Control 1: V/f Control with PG 2: Open Loop Vector Control 3: Closed Loop Vector Control 5: Open Loop Vector Control for PM 6: Advanced Open Loop Vector Control for PM 7: PM Closed Loop Vector Control	2	0: V/f Control 1: Closed Loop V/f Control 2: Open Loop Vector Control 3: Closed Loop Vector Control 4: Advanced Open Loop Vector Control 5: PM Open Loop Vector Control 6: PM Advanced Open Loop Vector Control 7: PM Closed Loop Vector Control 8: EZ Open Loop Vector Control
A1-03	Initialize Parameters	0	0: No initialization 1110: User Initialize 2220: 2-Wire initialization 3330: 3-Wire initialization 5550: oPE04 error reset	0	0: No initialization 1110: User initialization 2220: 2-Wire initialization 3330: 3-Wire initialization
A2-□□	User Parameters	Determined by A1-06.		Determined by A1-06.	(Includes P, Q, and S parameters when applicable.)
b3-24	Speed Search Method Selection	0	0: Current Detection 1: Speed Estimation	2	1: Speed Estimation 2: Current Detection 2
b3-33	Speed Search Selection when Run Command is Given during Uv	0	0: Disabled 1: Enabled	1	0: Disabled 1: Enabled
b4-03	H2-01 ON Delay Time	0	0 - 65535 ms	0	0 - 65000 ms
b4-04	H2-01 OFF Delay Time	0	0 - 65535 ms	0	0 - 65000 ms
b4-05	H2-02 ON Delay Time	0	0 - 65535 ms	0	0 - 65000 ms
b4-06	H2-02 OFF Delay Time	0	0 - 65535 ms	0	0 - 65000 ms
b4-07	H2-03 ON Delay Time	0	0 - 65535 ms	0	0 - 65000 ms
b4-08	H2-03 OFF Delay Time	0	0 - 65535 ms	0	0 - 65000 ms

7 Transfer of Parameter Settings

Parameter No.	Name	A1000		GA800	
		Default Setting	Setting Range	Default Setting	Setting Range
b5-15	PID Sleep Function Start Level	0.0	0.0 - 400.0 Hz	0.0	0.0 - 590.0 Hz <I>
b6-01	Dwell Reference at Start	0.0	0.0 - 400.0 Hz	0.0	0.0 - 590.0 Hz <I>
b6-03	Dwell Reference at Stop	0.0	0.0 - 400.0 Hz	0.0	0.0 - 590.0 Hz <I>
b8-01	Energy Saving Control Selection	0	0: Disabled 1: Enabled	0	0: Disabled 1: Enabled 2: Search Enabled
C1-11	Accel/Decel Time Switching Frequency	0.0	0.0 - 400.0 Hz	0.0	0.0 - 590.0 Hz <I>
C3-16	Output Voltage Limit Operation Start Level (Percentage Modulation)	85.0	70.0 - 90.0%	90.0	70.0 - 90.0%
C3-17	Maximum Output Voltage Limit Level (Percentage Modulation)	90.0	85.0 - 100.0%	100.0	85.0 - 100.0%
C3-18	Output Voltage Limit Level	90.0	30.0 - 100.0%	90.0	50.0 - 100.0%
C5-02	ASR Integral Time 1	Determined by A1-02.	0.000 - 10.000 s	Determined by A1-02.	0.000 - 60.000 s
C5-04	ASR Integral Time 2	Determined by A1-02.	0.000 - 10.000 s	Determined by A1-02.	0.000 - 60.000 s
C5-07	ASR Gain Switching Frequency	0.0	0.0 - 400.0 Hz	0.0	0.0 - 590.0 Hz <I>
C5-22	Motor 2 ASR Integral Time 1	Determined by E3-01.	0.000 - 10.000 s	0.000 - 60.000 s	Determined by E3-01. 0.000 - 60.000 s
C5-24	Motor 2 ASR Integral Time 2	Determined by E3-01.	0.000 - 10.000 s	0.000 - 60.000 s	Determined by E3-01. 0.000 - 60.000 s
C5-27	Motor 2 ASR Gain Switching Frequency	0.0	0.0 - 400.0 Hz	0.0	0.0 - 590.0 Hz <I>
d1-01 - d1-16	Frequency Reference 1 - Frequency Reference 16	0.0	0.0 - 400.0 Hz	0.0	0.0 - 590.0 Hz <I>
d1-17	Jog Frequency Reference	6.0	0.0 - 400.0 Hz	6.0	0.0 - 590.0 Hz <I>
d3-01	Jump Frequency 1	0.0	0.0 - 400.0 Hz	0.0	0.0 - 590.0 Hz <I>
d3-02	Jump Frequency 2	0.0	0.0 - 400.0 Hz	0.0	0.0 - 590.0 Hz <I>
d3-03	Jump Frequency 3	0.0	0.0 - 400.0 Hz	0.0	0.0 - 590.0 Hz <I>
d6-02	Field Weakening Frequency Limit	0.0	0.0 - 400.0 Hz	0.0	0.0 - 590.0 Hz <I>
E1-05	Maximum Output Voltage	200 V (E1-03 ≠ F)	200 V Class: 0.0 - 255.0 V 400 V Class: 0.0 - 510.0 V	230 V	Determined by A1-02. Note: E1-08, E1-10 also scaled based 230 V.
E2-04	Motor Pole Count	4	2 - 48	4	2 - 120
E2-06	Motor Leakage Inductance	Determined by o2-04 and C6-01.	0.0 - 40.0%	Determined by o2-04 and C6-01.	0 - 60.0%
H1-□□	Multi-Function Digital Input Settings	-	0 to 19F	-	3E: PID Setpoint Selection 1 3F: PID Setpoint Selection 2
H2-01	Terminal M1-M2 Function Selection (relay)	0	0 to 192	0	0 to 1A7

7 Transfer of Parameter Settings

Parameter No.	Name	A1000		GA800	
		Default Setting	Setting Range	Default Setting	Setting Range
H2-02 (H2-03 in GA800)	Terminal M3-M4 Function Selection	1	0 to 192	-	Overwrites the value set to H2-03.
H2-03 (H2-04 in GA800)	Terminal M5-M6 Function Selection	2	0 to 192	-	Overwrites the value set to H2-04.

<1> A1-02 = 0, 2 or 5 (0.0 to 590 Hz), A1-02 = 1, 3, 6 or 7 (0.0 to 400 Hz), A1-02 = 4 or 8 (0.0 to 120 Hz)

8 Carrier Frequency - C6-02 [Carrier Frequency Selection]

To understand the effect of changing the Carrier Frequency on your new replacement drive, refer to the GA800 Technical Reference SIEPC71061737, Section 10.7 Drive Derating, Carrier Frequency Settings and Rated Current Values.
Download here: <http://www.yaskawa.com/SIEPC71061737>

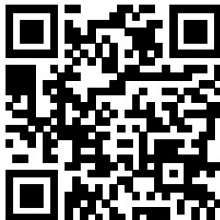

9 Watt Loss Comparison

Use this section to understand the watt loss difference between the A1000 and GA800. This is useful to ensure proper cooling for GA800 drives that replace A1000 drives inside of enclosures.

Understanding the “Difference” columns in *Table 16* and *Table 17*:

- A positive number = GA800 has less watt loss compared to A1000.
- A negative number = GA800 has greater watt loss compared to A1000.

Table 16 Watt Loss Comparison A1000 to GA800 (Normal Duty, Parameter C6-01 = 1)

A1000				GA800				Difference		
Model	Watt Loss			Catalog Code	Watt Loss			Watt Loss		
CIMR-AU	Interior	External	Total	GA80U	Interior	External	Total	Interior	External	Total
240 V										
2A0004	47	18.4	66	2004	35	18	53	12	0.4	13
2A0006	51	31	82	2006	38	25	63	13	6	19
2A0008	52	43	95	2008	42	34	76	10	9	19
2A0010	58	57	115	2010	49	46	95	9	11	20
2A0012	64	77	141	2012	56	62	118	8	15	23
2A0018	67	101	168	2018	53	88	141	14	13	27
2A0021	83	138	222	2021	75	125	200	8	13	22
2A0030	117	262	379	2030	95	206	301	22	56	78
2A0040	145	293	437	2042	129	227	356	16	66	81
2A0056	175	371	546	2056	149	302	451	26	69	95
2A0069	205	491	696	2070	177	403	580	28	88	116
2A0081	257	527	785	2082	202	467	669	55	60	116
2A0110	286	719	1005	2110	192	631	823	94	88	182
2A0138	312	842	1154	2138	269	814	1083	43	28	71
2A0169	380	1014	1394	2169	338	941	1279	42	73	115
2A0211	473	1218	1691	2211	384	1131	1515	89	87	176
2A0250	594	1764	2358	2257	519	1534	2053	75	230	305
2A0312	665	2020	2686	2313	579	1794	2373	86	226	313
2A0360	894	2698	3591	2360	655	2071	2726	239	627	865
2A0415	954	2672	3626	2415	608	2156	2764	346	516	862
480 V										
4A0002	48	20	68	4002	39	16	55	9	4	13
4A0004	49	32	81	4004	44	33	77	5	-1	4
4A0005	53	45	97	4005	48	31	79	5	14	18
4A0007	59	62	121	4007	52	44	96	7	18	25
4A0009	60	66	126	4009	42	58	100	18	8	26
4A0011	73	89	162	4012	57	84	141	16	5	21
4A0018	108	177	285	4018	82	144	226	26	33	59
4A0023	138	216	354	4023	108	185	293	30	31	61
4A0031	161	295	455	4031	138	222	360	23	73	95
4A0038	182	340	521	4038	145	270	415	37	70	106
4A0044	209	390	599	4044	168	335	503	41	55	96
4A0058	215	471	686	4060	157	444	601	58	27	85
4A0072	265	605	870	4075	185	527	712	80	78	158
4A0088	308	684	993	4089	212	665	877	96	19	116
4A0103	357	848	1205	4103	264	766	1030	93	82	175
4A0139	534	1215	1749	4140	393	1126	1519	141	89	230
4A0165	668	1557	2224	4168	574	1348	1922	94	209	302
4A0208	607	1800	2408	4208	493	1465	1958	114	335	450
4A0250	803	2379	3182	4250	686	1738	2424	117	641	758
4A0296	905	2448	3353	4302	817	2257	3074	88	191	279

9 Watt Loss Comparison

A1000				GA800				Difference		
Model	Watt Loss			Catalog Code	Watt Loss			Watt Loss		
CIMR-AU	Interior	External	Total	GA80U	Interior	External	Total	Interior	External	Total
4A0362	1130	3168	4298	4371	1022	2553	3575	108	615	723
4A0414	1295	3443	4738	4414	873	2422	3295	422	1021	1443
	-			4477	1183	3329	4512	-	-	-
4A0515	1668	4850	6518	4568	1429	3989	5418	239	861	1100
4A0675	2037	4861	6898	4605	1526	4572	6098	511	289	800
	-			4720	1723	5184	6907		-	
4A0930	2952	8476	11428	4810	2385	6626	9011	567	1850	2417
				4930	2465	7613	10078	487	863	1350
4A1200	3612	8572	12184	4H11	3162	9020	12182	450	-448	2
				4H12	3236	9931	13167	376	-1359	-983
600 V										
				5002	17	17	35	-	-	-
5A0003	21.5	23.3	44.8	5003	19	23	43	2.5	0.3	1.8
5A0004	27.5	33.6	61.1	5004	21	30	52	6.5	3.6	9.1
5A0006	28.1	43.7	71.8	5006	27	44	71	1.1	-0.3	-0.8
5A0009	43.4	68.9	112.3	5009	37	63	101	6.4	5.9	11.3
5A0011	56.1	88	144	5011	48	79	127	8.1	9.0	17.0
5A0017	96.6	146.7	243.2	5017	60	120	180	36.6	26.7	63.2
5A0022	99.4	178.3	277.7	5022	86	163	249	13.4	15.3	28.7
5A0027	132.1	227.2	359.3	5027	93	216	309	39.1	11.2	50.3
5A0032	141.6	279.9	421.5	5032	125	267	392	16.6	12.9	29.5
5A0041	136.2	330.8	467	5041	167	355	522	-30.8	-24.2	-55.0
5A0052	166.2	427.8	594	5052	229	474	703	-62.8	-46.2	-109.0
5A0062	279	791.2	1070.2	5062	156	655	812	123.0	136.2	258.2
5A0077	329.4	959.1	1288.6	5077	177	822	998	152.4	137.1	290.6
5A0099	411.7	1253.2	1664.9	5099	211	1103	1314	200.7	150.2	350.9
5A1025	537	1641	2178	5125	309	1694	2003	228	-53	175
5A1045	603	1860	2463	5144	350	1966	2316	253	-106	147
5A1092	769	2420	3189	5192	542	2098	2641	227	322	548
5A0242	1131	3100	4231	5242	676	2632	3308	455	468	923

Table 17 Watt Loss Comparison A1000 to GA800 (Heavy Duty, Parameter C6-01 = 0)

A1000				GA800				Difference		
Model	Watt Loss			Catalog Code	Watt Loss			Watt Loss		
CIMR-AU	Interior	External	Total	GA80U	Interior	External	Total	Interior	External	Total
240 V										
2A0004	44	14.8	59	2004	35	19	54	9	-4.2	5
2A0006	48	24	72	2006	37	26	63	11	-2	9
2A0008	49	35	84	2008	40	36	76	9	-1	8
2A0010	52	43	95	2010	44	43	87	8	0	8
2A0012	58	64	122	2012	50	61	111	8	3	11
2A0018	60	77	137	2018	47	82	129	13	-5	8
2A0021	67	101	168	2021	56	105	161	11	-4	7
2A0030	92	194	287	2030	74	174	248	18	20	39
2A0040	105	214	319	2042	88	183	271	17	31	48
2A0056	130	280	410	2056	112	267	379	18	13	31
2A0069	163	395	558	2070	145	373	518	18	22	40
2A0081	221	460	681	2082	179	478	657	42	-18	24
2A0110	211	510	721	2110	155	563	718	56	-53	3
2A0138	250	662	912	2138	212	680	892	38	-18	20
2A0169	306	816	1122	2169	275	820	1095	31	-4	27
2A0211	378	976	1354	2211	314	991	1305	64	-15	49

9 Watt Loss Comparison

A1000				GA800				Difference		
Model	Watt Loss			Catalog Code	Watt Loss			Watt Loss		
CIMR-AU	Interior	External	Total	GA80U	Interior	External	Total	Interior	External	Total
2A0250	466	1514	1980	2257	398	1252	1650	68	262	330
2A0312	588	1936	2524	2313	502	1643	2145	86	293	379
2A0360	783	2564	3347	2360	582	1978	2560	201	586	787
2A0415	954	2672	3626	2415	644	2359	3003	310	313	623
480 V										
4A0002	45	15.9	61	4002	38	15	53	7	0.9	8
4A0004	46	25	70	4004	42	28	70	4	-3	0
4A0005	49	37	87	4005	46	37	83	3	0	4
4A0007	53	48	101	4007	48	45	93	5	3	8
4A0009	55	53	108	4009	37	61	98	18	-8	10
4A0011	61	69	130	4012	46	82	128	15	-13	2
4A0018	86	135	221	4018	65	140	205	21	-5	16
4A0023	97	150	247	4023	73	150	223	24	0	24
4A0031	115	208	323	4031	101	211	312	14	-3	11
4A0038	141	263	403	4038	119	272	391	22	-9	12
4A0044	179	330	509	4044	148	354	502	31	-24	7
4A0058	170	349	518	4060	126	389	515	44	-40	3
4A0072	217	484	701	4075	165	527	692	52	-43	9
4A0088	254	563	817	4089	184	617	801	70	-54	16
4A0103	299	723	1022	4103	237	779	1016	62	-56	6
4A0139	416	908	1325	4140	300	956	1256	116	-48	69
4A0165	580	1340	1920	4168	486	1274	1760	94	66	160
4A0208	541	1771	2313	4208	446	1432	1878	95	339	435
4A0250	715	2360	3075	4250	558	1464	2022	157	896	1053
4A0296	787	2391	3178	4302	692	2061	2753	95	330	425
4A0362	985	3075	4060	4371	824	2346	3170	161	729	890
4A0414	1164	3578	4742	4414	777	2212	2989	387	1366	1753
-	-	-	-	4477	963	2696	3659	-	-	-
4A0515	1386	3972	5358	4568	1183	3329	4512	203	643	846
4A0675	1685	4191	5875	4605	1328	3995	5323	357	196	552
-	-	-	-	4720	1395	4198	5593	-	-	-
4A0930	2455	6912	9367	4810	2036	5778	7814	419	1134	1553
4A1200	3155	7626	10781	4930	2120	6563	8683	335	349	684
-	-	-	-	4H11	2690	7708	10398	465	-82	383
-	-	-	-	4H12	2866	8917	11783	289	-1291	-1002
600 V										
-	-	-	-	5002	17	15	32	-	-	-
5A0003	19.8	28.9	48.7	5003	18	21	40	1.8	7.9	8.7
5A0004	27.6	54.3	81.9	5004	19	23	43	8.6	31.3	38.9
5A0006	27	53	80	5006	21	30	52	6.0	23.0	28.0
5A0009	36.4	78.7	115.1	5009	27	44	71	9.4	34.7	44.1
5A0011	49.5	110.9	160.3	5011	37	63	101	12.5	47.9	59.3
5A0017	67.5	144.7	212.2	5017	40	76	116	27.5	68.7	96.2
5A0022	81.1	203.8	284.8	5022	60	120	180	21.1	83.8	104.8
5A0027	113.8	267.2	381.1	5027	72	169	241	41.8	98.2	140.1
5A0032	132.2	332.9	465.1	5032	102	216	318	30.2	116.9	147.1
5A0041	127.6	405.9	533.5	5041	115	255	370	12.6	150.9	163.5
5A0052	161.4	527.2	688.5	5052	167	355	522	-5.6	172.2	166.5
5A0062	335	1271.5	1606.5	5062	143	545	688	192.0	726.5	918.5
5A0077	379.5	1457	1836.5	5077	156	655	812	223.5	802.0	1024.5
5A0099	352	1267	1619	5099	177	822	998	175.0	445.0	621.0

9 Watt Loss Comparison

A1000				GA800				Difference		
Model	Watt Loss			Catalog Code	Watt Loss			Watt Loss		
CIMR-AU	Interior	External	Total	GA80U	Interior	External	Total	Interior	External	Total
5A1025	422	1328	1750	5125	259	1324	1583	163	4	167
5A0145	508	1638	2146	5144	308	1652	1959	200	-14	187
5A0192	648	2114	2762	5192	440	1749	2188	208	365	574
5A0242	896	2526	3422	5242	526	2040	2566	370	486	856

10 Control I/O Option Compatibility

A1000 network communication and I/O options are generally compatible with GA800. Firmware inside these options may require an update to support GA800. Refer to the “Applicable Products” section of the specific Option Installation Manual on www.yaskawa.com to get the compatible firmware version required in the option card.

Navigate to the “Options” section of the GA800 product page for more information on GA800 compatible options.

Url: <https://www.yaskawa.com/products/drives/industrial-ac-drives/general-purpose-drives/ga800-drive/>

Home / Products / Drives / Industrial AC Drives / General Purpose Drives / GA800 Drive Print

Products

Drives

- Industrial AC Drives >
- General Purpose Drives >
- GA800 Drive
- A1000 Drive
- A1000 Configured
- U1000 Industrial MATRIX Drive
- G7 Drive
- G7 Configured

Microdrives >

Fan & Pump Drives >

System Components >

GA800 Drive



3/4 - 600 HP

The Yaskawa GA800 drive provides the ultimate combination of power, ease of use, flexibility, and performance. In addition to its exceptional torque production and precise control, you'll enjoy effortless setup with GA800's high-resolution display and connection to your favorite mobile device. Whether you need simple control, advanced network communications, or functional safety, look no further than GA800 for all your variable speed needs.

[Video](#) [Flyer](#) [Selection Guide](#) [Technical Manual](#) [Core Manuals](#)

Overview ▾ **Options ▾** Software ▾ Support & Training ▾ Documents ▾ Drawings ▾

Features

- Network Communications
- Feedback

Highlights

- ▶ High resolution Input & Output with Setup Wizards and Data-Logging.
- ▶ Bluetooth and Keypads & Cables for convenient and easy interaction.
- ▶ Programming Power for embedded USB port.
- ▶ DriveWizard Enclosures for configuration and monitoring.

Refer to the GA800 Selection Guide No. SL.GA800.01 for a complete list of GA800 options. Download here: <http://www.yaskawa.com/SL.GA800.01>



11 Other Option Compatibility

Use this section to understand the compatibility of other A1000 options for the GA800.

Navigate to the “Options” section of the GA800 product page for more information on GA800 compatible options.

Url: <https://www.yaskawa.com/products/drives/industrial-ac-drives/general-purpose-drives/ga800-drive/>

- **GA800 Keypad dimensions:**

GA800 Keypad dimensions and the mounting position differ between A1000 and GA800. The A1000 keypad panel cut-out dimension will not fit the GA800 keypad. The keypad panel attachment (operator mounting bracket) for A1000 is not compatible with GA800. The GA800 panel attachment must be used.

- **Braking resistor option (LKEB):**

The A1000 braking resistor installation attachment that mounts braking resistor to the back of drive heatsink is not compatible with GA800. The GA800 requires a special attachment. Refer to the **GA800 Selection Guide SL.GA800.01** for braking resistor mounting hardware.

- **Braking units (CDBR Type):**

The braking unit can be transferred to GA800 without making any changes. If using a braking unit with model GA80U2056 or below (200 V class), or model GA80U4038 or below (400 V class), set L8-55 = 0 [Internal Braking Transistor Protection = Disabled].

- **AC or DC reactor:**

The AC or DC reactor can be transferred to GA800 without making any changes.

Refer to the GA800 Selection Guide No. SL.GA800.01 for a complete list of GA800 options.

Download here: <http://www.yaskawa.com/SL.GA800.01>



YASKAWA

A1000 to GA800 PRODUCT TRANSITION GUIDE

YASKAWA AMERICA, INC.

2121, Norman Drive South, Waukegan, IL
60085, U.S.A.
+1-800-YASKAWA (927-5292)
www.yaskawa.com

DRIVE CENTER (INVERTER PLANT)

2-13-1, Nishimiyaichi, Yukuhashi, Fukuoka,
824-8511, Japan
Phone: +81-930-25-2548
www.yaskawa.co.jp

YASKAWA EUROPE GmbH

Hauptstraße 185, 65760 Eschborn, Germany
Phone: +49-6196-569-300
E-mail: support@yaskawa.eu.com
www.yaskawa.eu.com

YASKAWA ELÉTRICO DO BRASIL LTDA.

777, Avenida Piraporinha, Diadema, São
Paulo, 09950-000, Brasil
Phone: +55-11-3585-1100
www.yaskawa.com.br

In the event that the end user of this product is to be the military and said product is to be employed in any weapons systems or the manufacture thereof, the export will fall under the relevant regulations as stipulated in the Foreign Exchange and Foreign Trade Regulations. Therefore, be sure to follow all procedures and submit all relevant documentation according to any and all rules, regulations and laws that may apply.

Specifications are subject to change without notice for ongoing product modifications and improvements.

Original instructions.

© 2019 YASKAWA Electric Corporation

YASKAWA ELECTRIC CORPORATION



PL_GA800.01

PL.GA800.01
Revision: F <5>-0
February 2026
Published in USA